

A Monthly Journal for Yamaha World-Wide Dealers



YAMAHA NEWS

1967
NO.6

OCTOBER

YAMAHA CLINCHES 125cc TITLE WITH PERFECT SCORE

Yamaha concluded this year's 125cc title battle by winning the Ulster GP on August 19 after adding wins in the East German and the Czech. Grand Prix in July.

Yamaha clinched the 125cc title with a perfect score of 56 points, setting thirteen new records even though there were still three more rounds left to go.



B. Ivy and P. Read on fantastic 4-cylinder Yamahas speeding their way to the 1967 titles.

WORLD GP

East German GP—July 16

The sixth round of the series was fought at the 8.6 km Sachsenring Circuit near Karl Marx City. In spite of S. Graham's determined riding, B. Ivy and P. Read on Yamahas dominated the race, taking first and second places, and setting new lap and race records.

Final results - 125 cc class, 12 laps - 103.368 km

- | | | | |
|--------------|--------|----------|-------------|
| 1. B. Ivy | Yamaha | 39' 38"9 | 156.43 km/h |
| | | | (record) |
| 2. P. Read | Yamaha | 40' 02"0 | 154.92 km/h |
| 3. S. Graham | Suzuki | 40' 09"2 | 154.46 km/h |
- Fastest lap - B. Ivy, 3'13"8 160.01 km/h (record)

Czech. GP—July 23

Yamaha proved unbeatable at the Czech. G. P. round as well. B. Ivy riding a Yamaha outclassed all but S. Graham on a Suzuki who managed to fill second place, at the 14 km Bruno Circuit. Ivy brought Yamaha its sixth win of the year with another new race record.

Final results - 125 cc class, 8 laps - 111.528 km

- | | | | |
|--------------|--------|----------|-------------|
| 1. B. Ivy | Yamaha | 45' 09"4 | 148.19 km/h |
| | | | (record) |
| 2. S. Graham | Suzuki | 45' 59"4 | 145.47 km/h |
| 3. L. Ssabo | MZ | 49' 54"1 | 134.10 km/h |

Ulster GP—August 19

Yamaha virtually captured the world title by taking first and second places in the Ulster Grand Prix, staged before a record crowd of 80,000 spectators on the 11.9 km Dundrod Circuit. Bill Ivy on a Yamaha roared to victory 0.2 seconds ahead of his team-mate P. Read, with S. Graham almost 2 minutes behind.

In brilliant weather, the two Yamaha aces thrilled the huge crowd by staging an almost wheel to wheel battle. Ivy broke both the race record and lap record by large margins.

Final results - 125 cc class, 11 laps - 131.93 km

- | | | | |
|--------------|--------|----------|-------------|
| 1. B. Ivy | Yamaha | 51' 30"2 | 152.58 km/h |
| | | | (record) |
| 2. P. Read | Yamaha | 51' 30"4 | 152.57 km/h |
| 3. S. Graham | Suzuki | 53' 27"0 | 147.05 km/h |
- Fastest lap - B. Ivy, 4' 37"6 160.21 km/h

URGENT IVY'S TITLE DECIDED-ITALIAN GP

B. Ivy clinched the 1967 title with a perfect score by winning the 125cc race at the Italian GP on September 3. In the 250cc class, P. Read also finished first. Now, he too is speeding to the world title.

YAMAHA RIDERS ROUTED THEIR opposition by making a clean sweep of all first places in the big Indonesian road race meeting which was recently held in Djakarta — the first event of this year. Benny Hoan riding a TD1-B became the hero of the day by snatching wins in the senior 250cc, 350cc and open class up to 500cc. In the senior 350cc class, other Yamaha riders rode their TD1-Bs into the second and third placings. Besides, in the senior openclass up to 100cc, T. T. Thio astride a Yamaha works machine outclassed the rest of the field with his team-mates on YL-1s finishing second and third.



B. Hoan, a hero of the day!

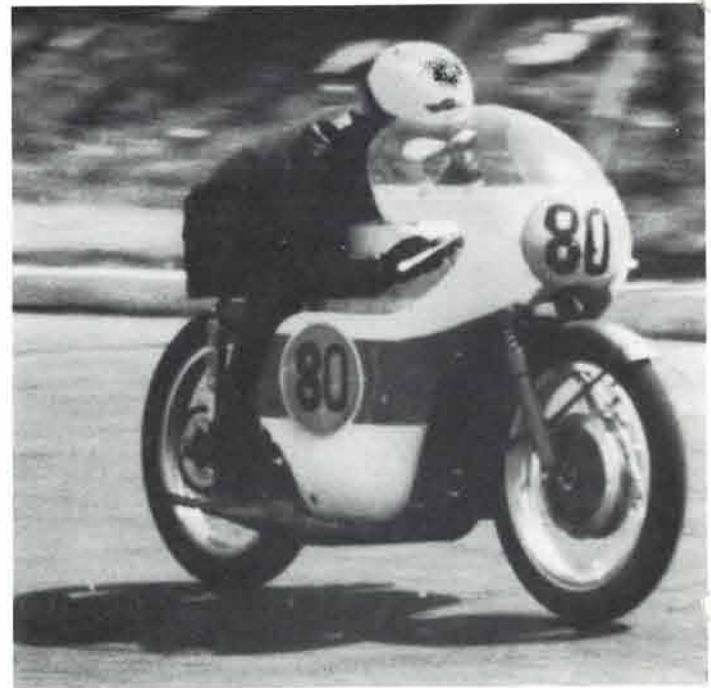

He is speeding the way to win.

INDONESIAN ROAD RACE RESULTS

Senior 90 cc

- | | |
|------------------|--------------|
| 1. Boy Oey S. T. | Yamaha YGS-1 |
| 2. L. T. Han | Honda |
| 3. T. S. Biau | Suzuki |

Senior 125 cc

- | | |
|------------------|-------------|
| 1. Sarsito S. A. | Yamaha YL-1 |
| 2. Boy Oey S. T. | " |
| 3. D. Abdulah | Suzuki |

Junior 100 cc

- | | |
|-------------|--------------|
| 1. Gunadi S | Yamaha YL-1 |
| 2. M. Liang | Yamaha YGS-1 |
| 3. Handoyo | Yamaha YL-1 |

Junior 125 cc

- | | |
|------------------|-------------|
| 1. Gunadi S | Yamaha YL-1 |
| 2. Yunarto | " |
| 3. Rony K. G. S. | " |



B. Hoan is starting from the extreme left.

NEW MODEL

Yamaha Sports 125 YAS-1

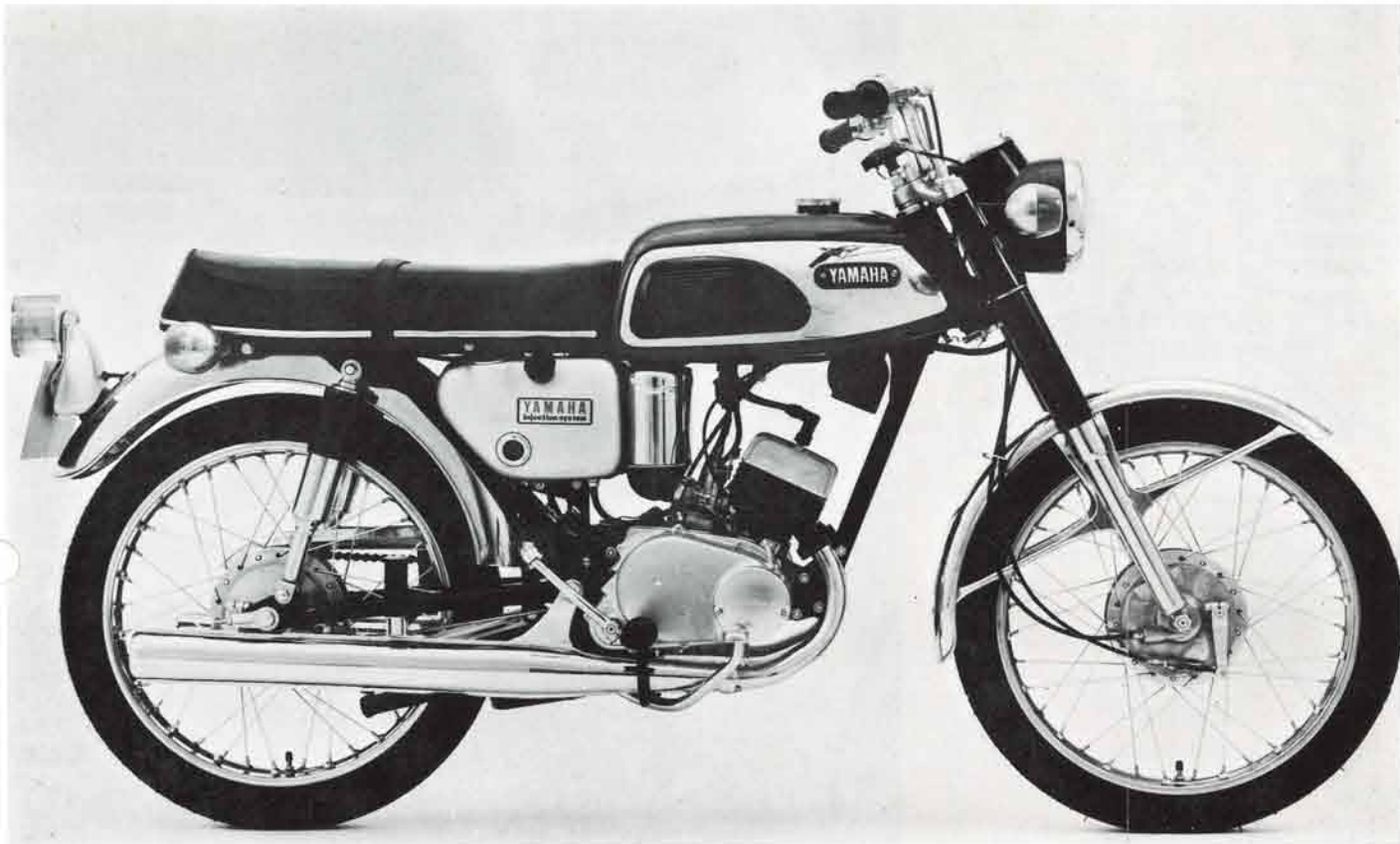

Sleek but tough

Following brilliant successes in the world championship road races, Yamaha is releasing brand-new sportster, the 125 YAS-1, to join the world famous Yamaha twin sport series.

Tests conducted abroad have already proven this model really worth noticing in many respects.

Yamaha's precise and race-developed technique has turned out this lightweight sportster which is sleek in appearance, but tough in performance. High hopes can be held that it will be the best in its class in the world.

Newly developed 5-port cylinder

The most significant change to the powerplant is the adoption of the 5-port cylinder which has been developed by Yamaha. This is regarded as Yamaha's most important technical innovation in the field of two-stroke motorcycle engineering since the adoption of rotary valves for standard models and the development of Autolube.

The 5-port cylinder eliminates unsatisfactory breathing, which is the main fault of conventional 3-port cylinders used in two-stroke engines.

In a 3-port cylinder, fresh fuel flows into the cylinder through two transfer ports. It is directed upwards in a loop, forcing the burnt gas out through an exhaust port. However, a residue of the burnt gas is left of the upper center of the cylinder.

Yamaha has completely remedied this fault of the 3-port cylinder by making two more transfer ports. Fresh fuel rushing into the cylinder through four passages can clean out burnt gases completely. Consequently, the powerplant delivers more power over a wider range of speeds. It produces a maximum output of 15 ps/

8,500 r. p. m. with no adverse effects. The peak torque is 1.30 Kg-m/8,000 r. p. m. These figures are the highest in this class.

More speed and higher performance

Yamaha's advanced designing has reduced the weight of this model to 98 kg by the adoption of a new diamond type frame. The YAS-1 gives high power combined with exciting performance. In fact, it performs like much bigger bikes. It can accelerate from 0 to 1/4 mile in 17.5 sec., and can cruise at up to 130 km/h.

Two different types of close-ratio five-speed transmission gear box are available for this model.

They are rotary and return type. Safety is assured by powerful waterproof brakes and larger lighting equipment for all riding conditions. Another innovation is a new permanent mag-generator with a silicon rectifier, which supplies the battery with rectified electricity. As it does not have a commutator, any novice may perform maintenance.

Each of the two carburetors is fitted with a high capacity air cleaner to raise intake efficiency to a maximum.

Yamaha's unique labyrinth packing is used for the center seal of the crankcase. The merits of this semi-permanent aluminum-alloy packing are self-evident. It gives longer life to the engine as it is not subject to damage by oil or heat.

One more feature of this model is Yamaha's Autolube to supply the engine with the proper amount of oil according to engine speed. It is unquestionably the source of high, reliable performance.

Attractive design winning style, and high performance backed by championship winning technique..... The Yamaha Sports 125 YAS-1 will never fail to arouse interest among sports enthusiasts throughout the world.

NEW / YAMAHA
125cc SPORTS YAS-1

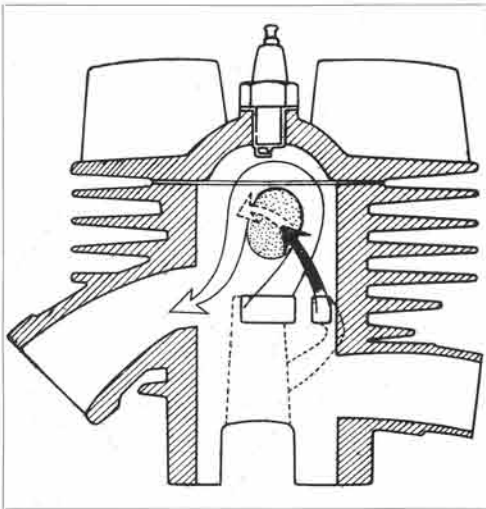

Fresh fuel charge rushing into the cylinder cleans out burnt gases leaving no residue in the upper center. (cut vertically)

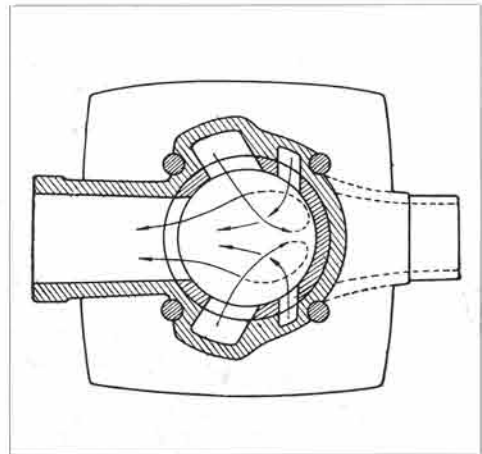

Fuel mixture introduced through four transfer passages forces burnt gases out. (cut horizontally)

Specifications

Engine type - 2-stroke twin,
 dual carburetors
 Displacement - 124 cc
 Bore and stroke - 43 x 43 mm
 Compression ratio - 7
 Starting system - kick
 Maximum output - 15 ps/8,500 r.p.m.
 Maximum torque - 1.30 kg-m/8,000 r.p.m.
 Top speed - 130 km/h
 Lubrication - Autolube
 Overall length - 1855 mm
 Overall width - 740 mm
 Overall height - 1070 mm
 Wheelbase - 1200 mm
 Dry weight - 98 kg
 Ground clearance - 150 mm
 120 ps per litre, 6.53 kg per ps
 Three-action rear swing arm

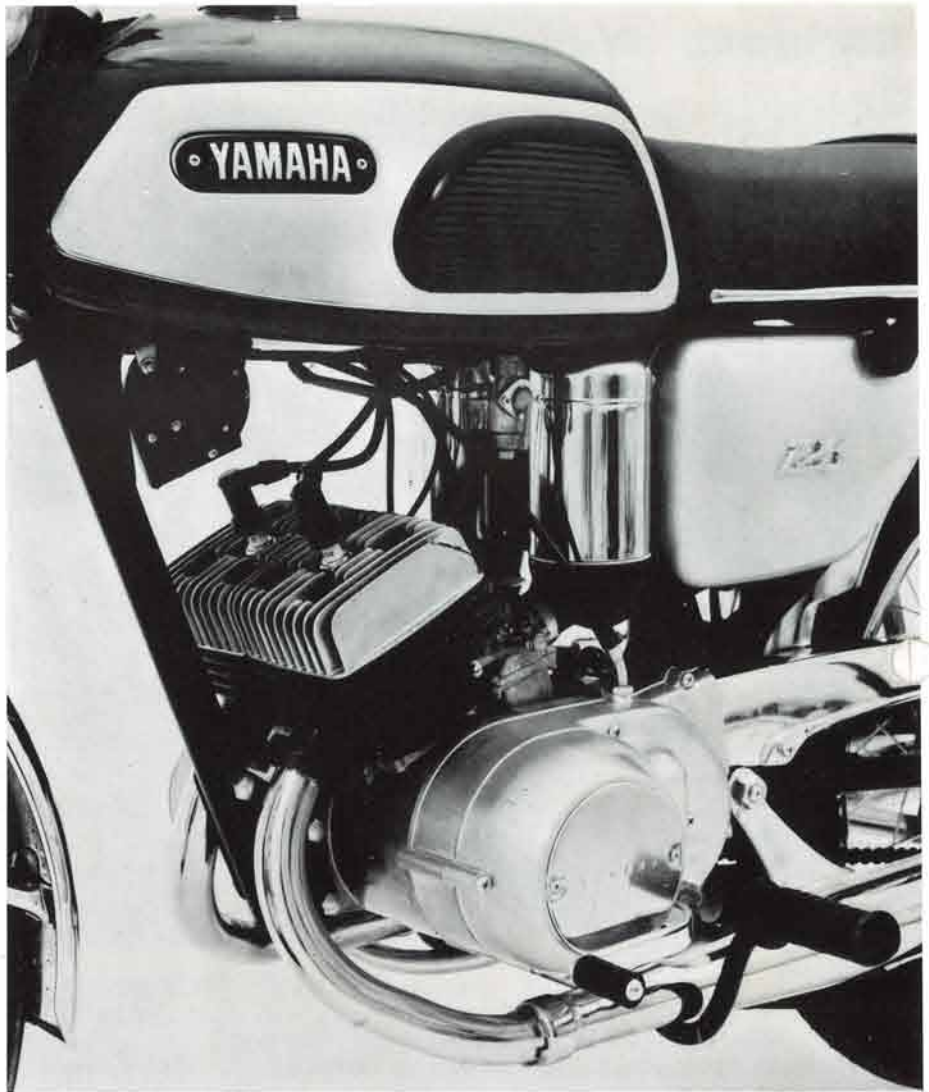

↑ Sensationally high output is delivered by this 5-port cylinder power plant.



A fresh styling feature is this new, larger air cleaner, mounted on the side of the oil tank. ↑



Greater illumination provided by improved lighting equipment assures safety. ↑

Utmost riding comfort is always guaranteed by triple-action rear dampers. ←

YAMAHA'S Topics

RACING SUCCESS is directly linked with sales promotion. The man pictured here proves it himself. He is Dominico Grupit, working for Yamaha of Hawaii as chief mechanic. His success in sports noticeably benefits the sales of his company throughout the major islands.



JIM REDMAN WINS THE FIRST RACE on a works Yamaha. The ex-champion rode a 1965 twin racer into an easy win in the 250cc class of a meeting held at the Swartkops Circuit near Pretoria, South Africa on July 29.



AMERICAN ENTHUSIASTS ENJOY A FEELING OF THE OLD WILD WEST hurling their Yamahas over a vast barren land near Los Angeles. This land is where Indians, in fact, used to gallop their wild horses so many years ago. Now, the horse has been replaced by the Yamaha YL2-C with an engine guard, upswept handle and muffler for trail riding.

These modern outlaws spent a day of fun and thrills astride their Yamahas, roaring over the rugged wastelands.



COMMENDING DEALERS FOR THEIR EXCELLENT SALES RECORDS is Mr. Genichi Kawakami, the President of the Yamaha Group. Besides motorcycles, the Group is producing motor boats, outboard motors, musical instruments, bath tubs and high-fidelity speakers. Mr. Kawakami's character is reflected in the internationally established reputation for high performance and quality of each Yamaha product.



YOUNGER THAN EVER was the winner of Mount. Cotton trial held near Brisbane, Australia on July 23. Although it was his first attempt in competition, Stephen Anderson, a ten-year old boy, rode a Yamaha YL2-C in such a masterly way that he was highest in the novice class against many experienced riders. It was notable also that young Stephen rode his father's YL2-C which was the first of this model to be imported into Australia.

YAMAHA TOPICS

YAMAHA MOTORCYCLES ARE GAINING MORE GROUND in the South African market. Dealers are attracting more customers by conducting service and riding schools. Ex-champion Jim Redman is leading the sales promotion for Charlie Young (Pty) Ltd., by riding a Yamaha for himself to demonstrate its exciting performance to South African enthusiasts.

If it were not for the current export quota system imposed by the Japanese Government, Yamaha's sales would be rising even more sharply.



1955 THE HISTORY OF YAMAHA 1967

TWELVE YEARS WITH YAMAHA

Rapid invasion into the sports world

It was in November, 1962 that the Motorcycling Federation of Japan (MFJ) organized the All Japan Championship Road Race Meeting at Suzuka, the first FIM approved circuit in Japan. At this meeting Yamaha won the main event, the 250cc class in which all of Japan's top riders competed. Brand-new Yamaha TD-1 production racers dominated the field, renewing the admiration of the 100,000 spectators for Yamaha machines.

With this impressive success in a big national event, Yamaha rapidly invaded the international sports field. The 1963 season opened with the US GP staged at the Daytona Beach circuit in February. This event was really worthy of special mention. For



Newcomers to the world classics. They attract the eyes of curiosity everywhere.

a newly-developed works twin ridden by F. Ito finished first in the 250cc class. It was Yamaha's first victory in one of the important international road races.



P. Read, the first champion on a Yamaha.

That same year the Yamaha racing team staked its first claim to the world championship. The TT, the third round of the season, was highlighted by Yamaha's tough challenge to the Honda 4-cylinder 250 cc racer which appeared invincible in those days. F. Ito's Yamaha twin proved just equal to J. Redman's Honda four. Eventually, Ito finished second after a thrilling race over the tortuous mountain circuit, but the Honda team had met with a terrible threat from a 2-stroke racer.

„Rising Sun over Spa" was the title of the Belgian GP race commentary written by an English reporter. It meant that a Japanese rider won a race. Indeed, F. Ito did it! He scored the first classic win astride a Yamaha breaking both lap and race records for this ultra-fast Francorchamps circuit. The second place was also taken by his Yamaha team-mate, Y. Sunako.

Professional observers commended that Yamaha had emerged as Honda's most powerful rival for championship honors.