

7 Assembling the Exhaust

First, assemble each component by following the working method and markings. Then, refer to the illustration and photos below to glue the parts together.

Indication of Working Methods

 Fold or Curve
  Adhere

EXHAUST

Sheet G, 26 parts in total

After assembling both Exhaust Pipes A and B, glue the two on the gluing surface shown below. Please use the ● dots on each component as reference when gluing surfaces.

[Exhaust A]

When assembling G-1 through G-8, refer to the photo of the finished model below to assemble them with the right angles.

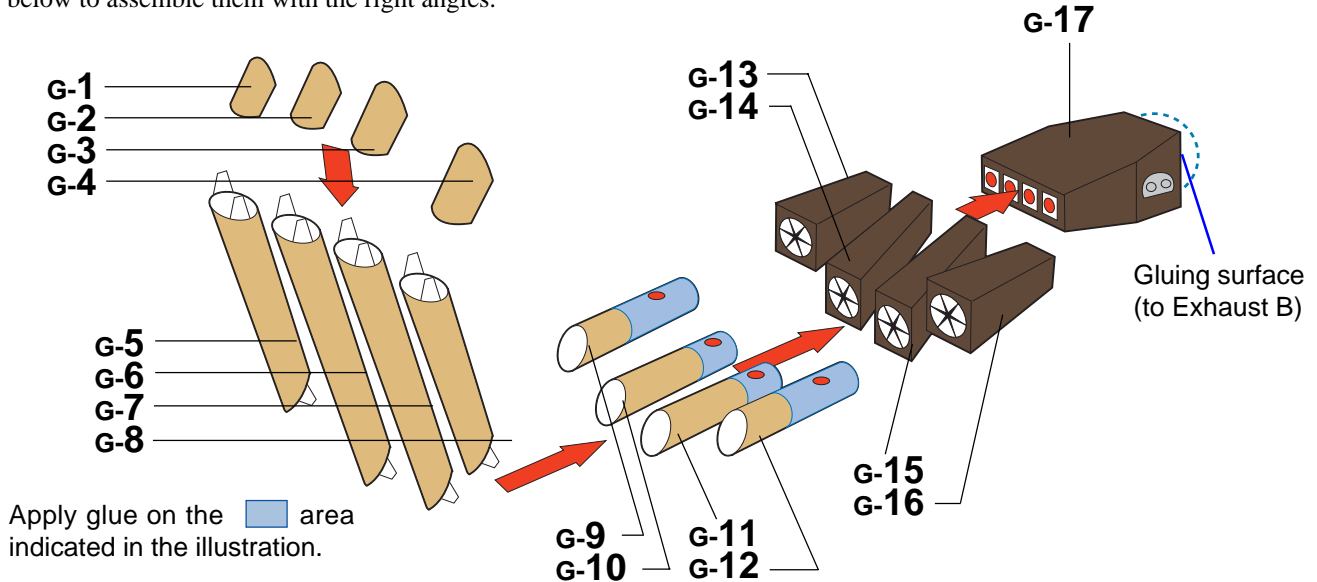

[Exhaust B]

When assembling G-18, 19, and 20, refer to the photo of the finished model below to assemble them with the right angles.

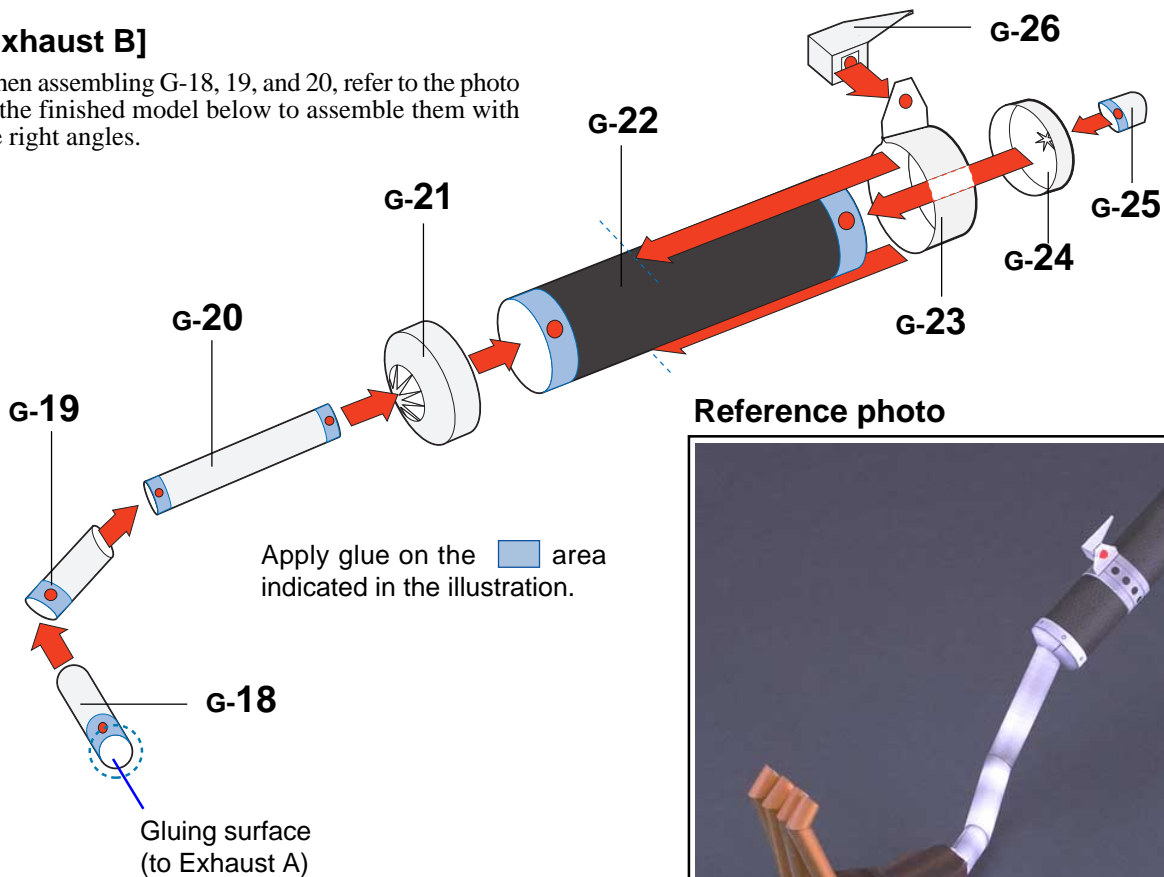

Reference photo



8 Assembling the Rear Arm

First, assemble each component by following the working method and markings. Then, refer to the illustration and photos below to glue the parts together.

Indication of Working Methods

 Fold or Curve  Adhere

REAR ARM

Sheet H, 11 parts in total

Please use the ● dots on each component as reference when gluing surfaces.

Follow the step-by-step assembly instructions ① ② ③ ④ shown below.

Assembly Instructions

- ① Glue H-1 and H-2 together.
- ② After assembling H-3 through the arm of H-1 as shown in the illustration, glue H-3 to H-1 and H-2.
- ③ Glue H-6 to H-1.
- ④ Glue H-4 to H-1. H-4 should straddle H-3 and H-6.

Refer to the illustration to assemble other parts.

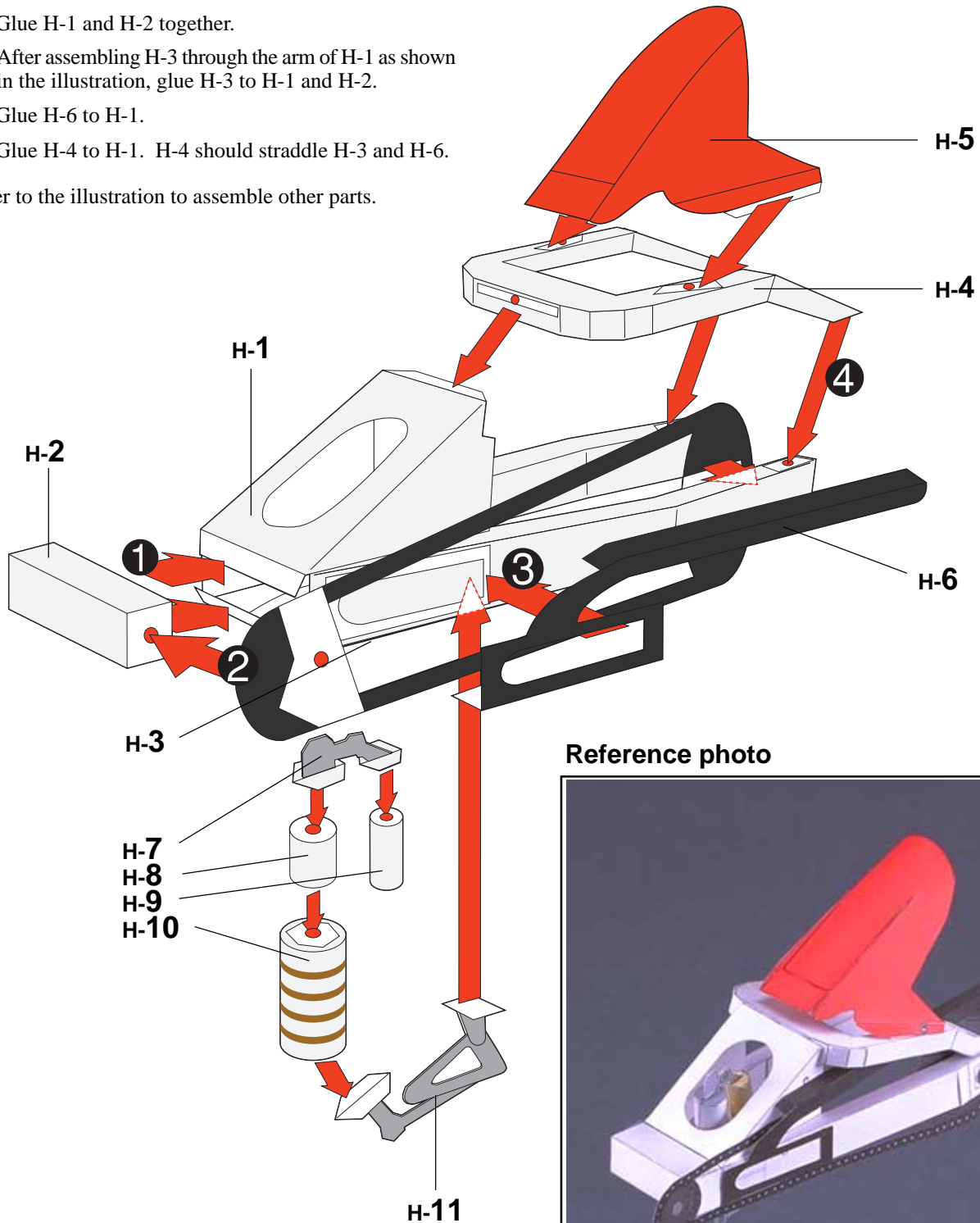

Reference photo



9 Assembling the Seat Cowl

First, assemble each component by following the working method and markings. Then, refer to the illustration and photos below to glue the parts together.

Indication of Working Methods



Fold or Curve



Adhere

SEAT COWL

Sheet 1, 13 parts in total

Please use the ● dots on each component as reference when gluing surfaces.

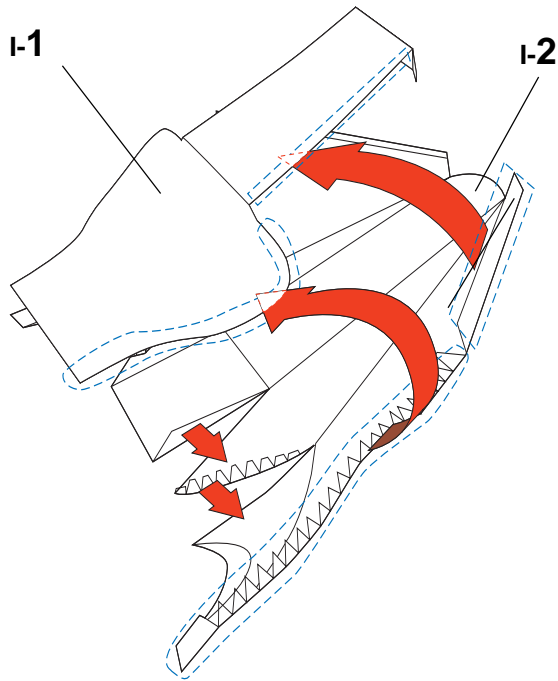
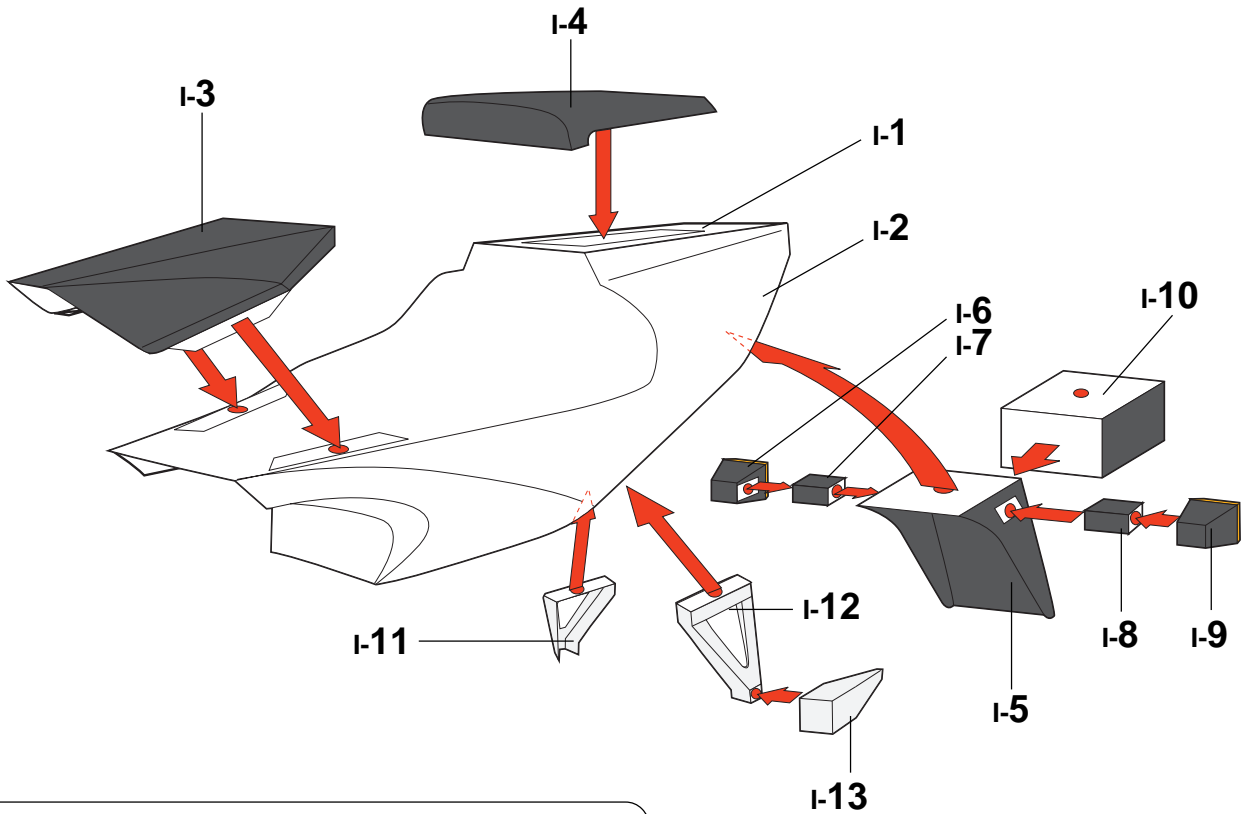

Fold the parts as shown above so that the dotted lines on the gluing surfaces are lined up before gluing each section.

Reference photo



10 Assembling the Front and Rear Tires

First, assemble each component by following the working method and markings. Then, refer to the illustration and photos below to glue the parts together.

Indication of Working Methods



Fold or Curve



Adhere

FRONT TIRE

Sheet J & L, 12 parts in total

Insert the assembled wheel in the assembled tire before gluing them together.

Please use the ● dots on each component as reference when gluing surfaces.

[Front Tire]

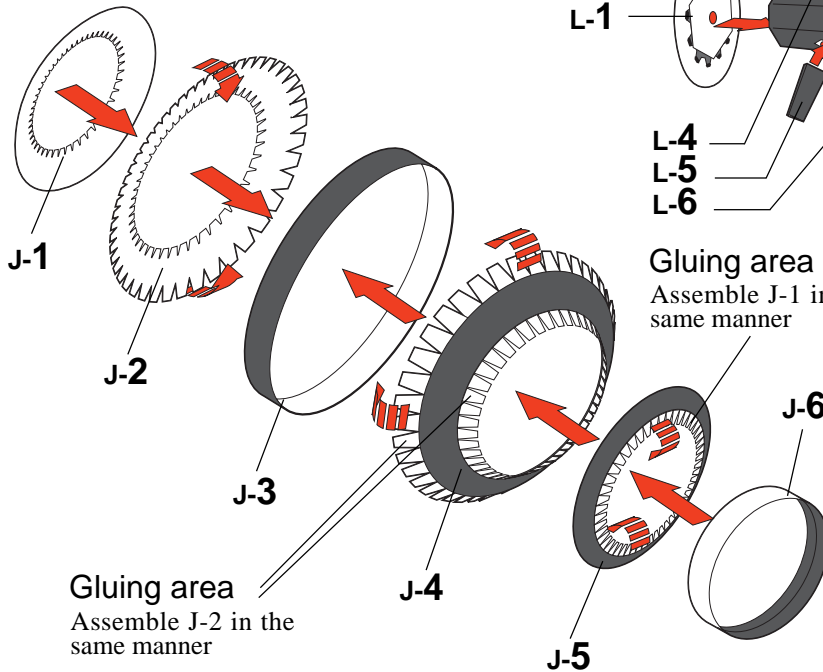

[Front Wheel]

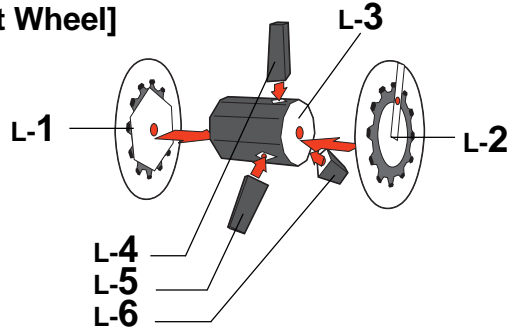

Gluing area
Assemble J-1 in the same manner

Reference photo



REAR TIRE

Sheet K & L, 13 parts in total

Insert the assembled wheel in the assembled tire before gluing them together.

Please use the ● dots on each component as reference when gluing surfaces.

[Rear Tire]

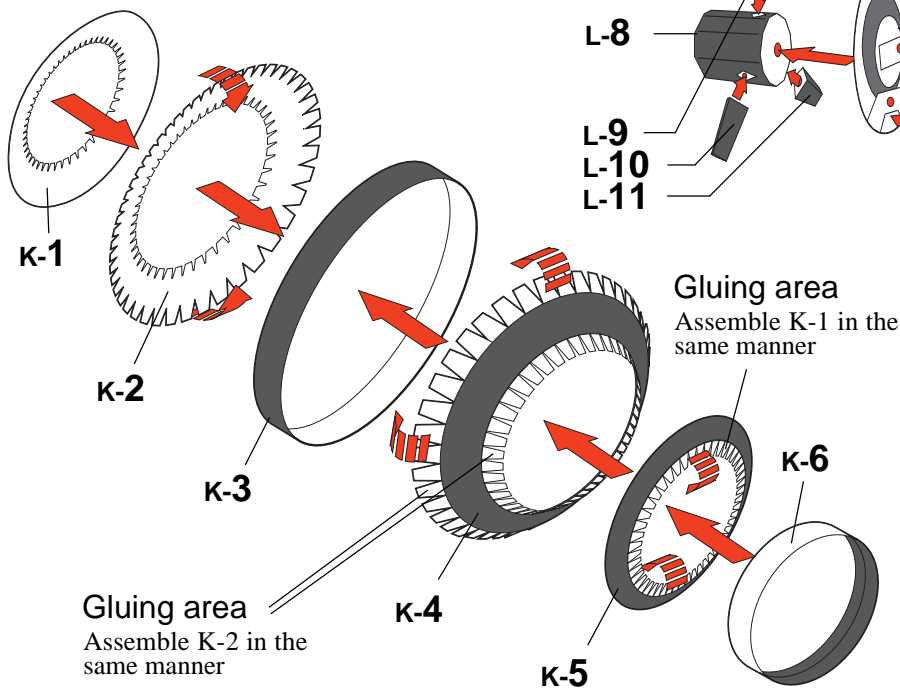

[Rear Wheel]

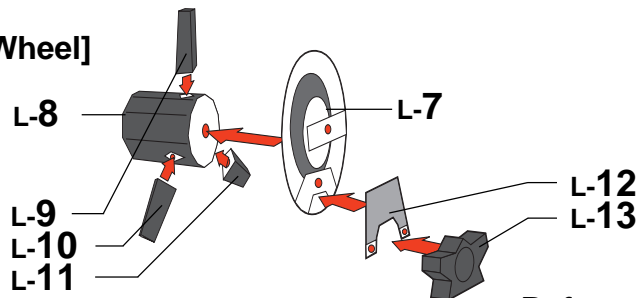

Gluing area
Assemble K-1 in the same manner

Reference photo

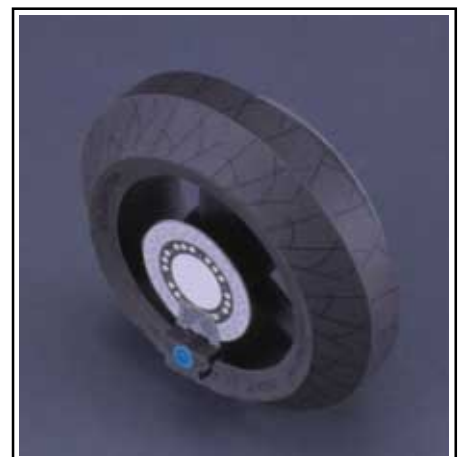

11 Finish

Assembly Instruction

glue the assembled parts in numerical order ① through ⑪.

Please use the ● dots on each component as reference when gluing surfaces.

