

# YK600XGLP

Dust-proof & drip-proof type

- Arm length 600mm
- Maximum payload 4kg

## Ordering method

**YK600XGLP-150** **S** **RCX340-4**

Model	Z axis stroke	Tool flange	Hollow shaft	Cable	Controller / Number of controllable axes	Safety standard	Option A (OP.A)	Option B (OP.B)	Option C (OP.C)	Option D (OP.D)	Option E (OP.E)	Absolute battery
	150: 150mm	No entry: None F: With tool flange	S: With hollow shaft	3L: 3.5m 5L: 5m 10L: 10m								

Specify various controller setting items. RCX340 ▶ **P.566**

## Specifications

		X-axis	Y-axis	Z-axis	R-axis
Axis specifications	Arm length	350 mm	250 mm	150 mm	-
	Rotation angle	+/-129 °	+/-144 °	-	+/-360 °
AC servo motor output		200 W	150 W	50 W	100 W
Deceleration mechanism	Transmission method	Direct-coupled			
	Motor to speed reducer Speed reducer to output	Direct-coupled			
Repeatability <sup>Note 1</sup>		+/-0.01 mm	+/-0.01 mm	+/-0.004 °	
Maximum speed		4.9 m/sec	1.1 m/sec	1020 °/sec	
Maximum payload		4 kg			
Standard cycle time: with 2kg payload <sup>Note 2</sup>		0.71 sec			
R-axis tolerable moment of inertia <sup>Note 3</sup>		0.05 kgm <sup>2</sup>			
Protection class <sup>Note 4</sup>		Equivalent to IP65 (IEC 60529)			
User wiring (sq × wires)		0.2 × 10			
User tubing (Outer diameter)		φ 4 × 4			
Travel limit		1.Soft limit 2.Mechanical stopper (X,Y,Z axis)			
Robot cable length		Standard: 3.5 m Option: 5 m, 10 m			
Weight		26 kg			

Note 1. This is the value at a constant ambient temperature. (X,Y axes)  
 Note 2. When reciprocating 25mm in vertical direction and 300mm in horizontal direction (rough-positioning arch motion).  
 Note 3. The acceleration coefficient is set automatically in accordance with the tip weight and R-axis moment of inertia settings.  
 Note 4. Do not use robots where the bellows section is directly exposed to water jet. Contact our distributor for information on drip-proof structure preventing liquid other than water.

## Controller

Controller	Power capacity (VA)	Operation method
RCX340	1000	Programming / I/O point trace / Remote command / Operation using RS-232C communication

Note. The movement range can be limited by changing the positions of X and Y axis mechanical stoppers. (The movement range is set to the maximum at the time of shipment.)  
 See our robot manuals (installation manuals) for detailed information.  
 Note. To set the standard coordinates with high accuracy, use a standard coordinate setting jig (option). Refer to the user's manual (installation manual) for more details.

Our robot manuals (installation manuals) can be downloaded from our website at the address below:  
<https://global.yamaha-motor.com/business/robot/>

## YK600XGLP

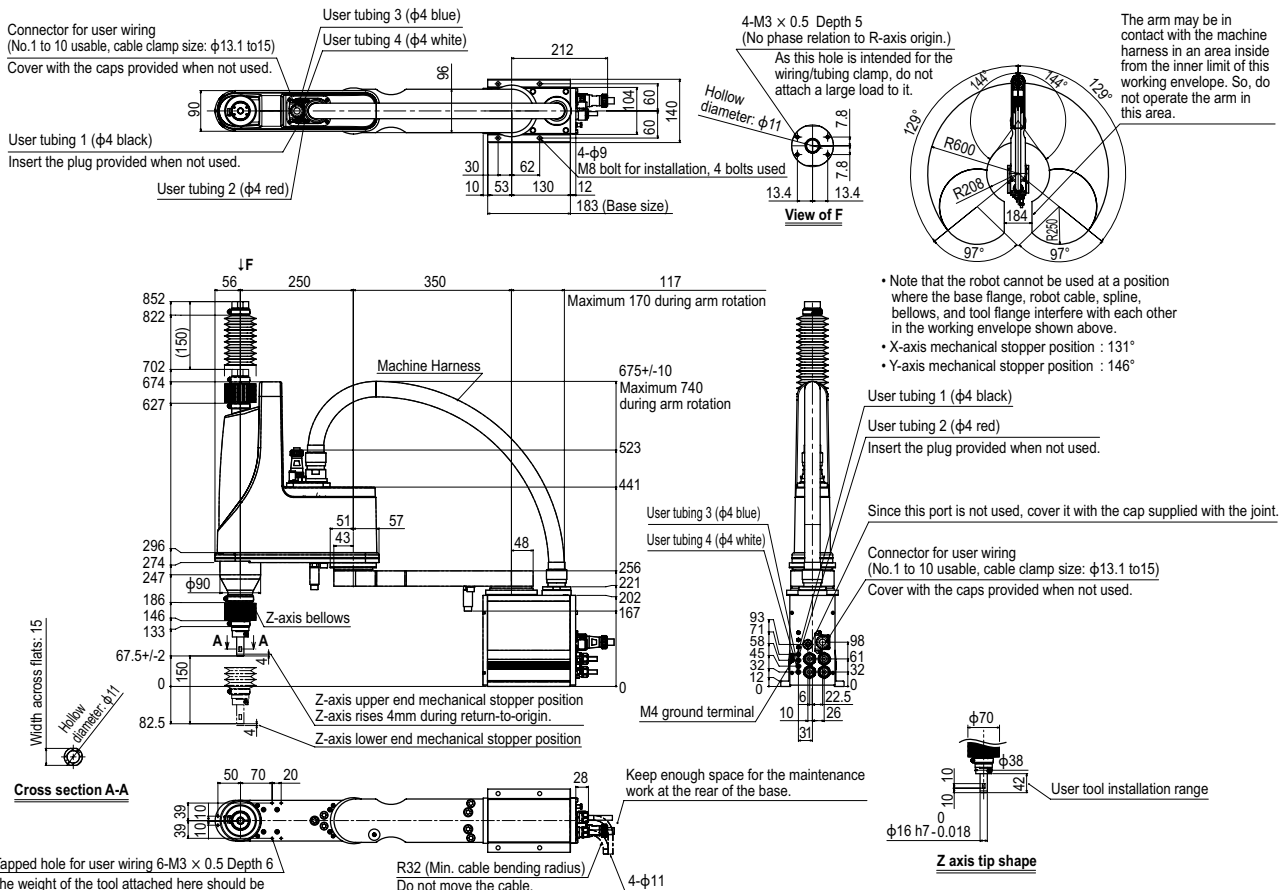

Articulated robots
YA
Linear conveyor modules
LCM100
Motor-less single axis reducer
Robonity
Compact single-axis robots
TRANSERVO
Single-axis robots
FLIP-X
Linear motor single-axis robots
PHASER
Cartesian robots
XY-X
SCARA robots
YK-X
Pick & place
YP-X
CLEAN
CONTROLLER INFORMATION
Orbit/ Extra small type
Small / Medium type
Large type
Wall mount / Inverse type
Dust-proof & drip-proof type

## YK600XGLP Tool flange mount type

