

SXYBx

2 axes / ZFL20

- XZ type
- Cable carrier
- Z-axis: clamped base / moving table type (200W)

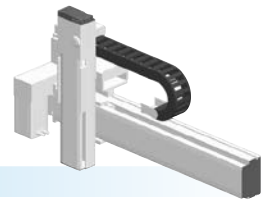

Ordering method

SXYBx - C [] [] **ZFL20** [] [] **RCX320-2** [] **R** [] [] [] [] [] []

Model Cable Combination X-axis stroke ZR-axis Z-axis stroke Cable

F1 15 to 305cm 3L: 3.5m
F3 15 to 35cm 5L: 5m
10L: 10m

Controller / Number of controllable axes Safety standard Regenerative unit Option A (OP.A) Option B (OP.B) Vision System Absolute battery

Specify various controller setting items. RCX320 ▶ **P.548**

RCX222 [] **R** [] [] [] [] []

Controller Usable for CE Regenerative unit I/O selection 1 I/O selection 2

Specify various controller setting items. RCX222 ▶ **P.558**

Specification

	X-axis	Z-axis
Axis construction ^{Note 1}	B14H	F10H-BK
AC servo motor output (W)	200	200
Repeatability ^{Note 2} (mm)	+/-0.04	+/-0.01
Drive system	Timing belt	Ball screw φ15
Ball screw lead ^{Note 3} (Deceleration ratio) (mm)	Equivalent to lead 25	20
Maximum speed (mm/sec)	1875	1200
Moving range (mm)	150 to 3050	150 to 350
Robot cable length (m)	Standard: 3.5 Option: 5, 10	

Note 1. Use caution that the flange machining (installation holes, tap holes) differs from single-axis robots.
 Note 2. Positioning repeatability in one direction.
 Note 3. Leads not listed in the catalog are also available. Contact us for details.

Maximum payload (kg)

X stroke (mm)	Z stroke (mm)
150 to 3050	8

Controller

Controller	Operation method
RCX320-R RCX222-R	Programming / I/O point trace / Remote command / Operation using RS-232C communication

SXYBx 2 axes / ZFL20 (F1)

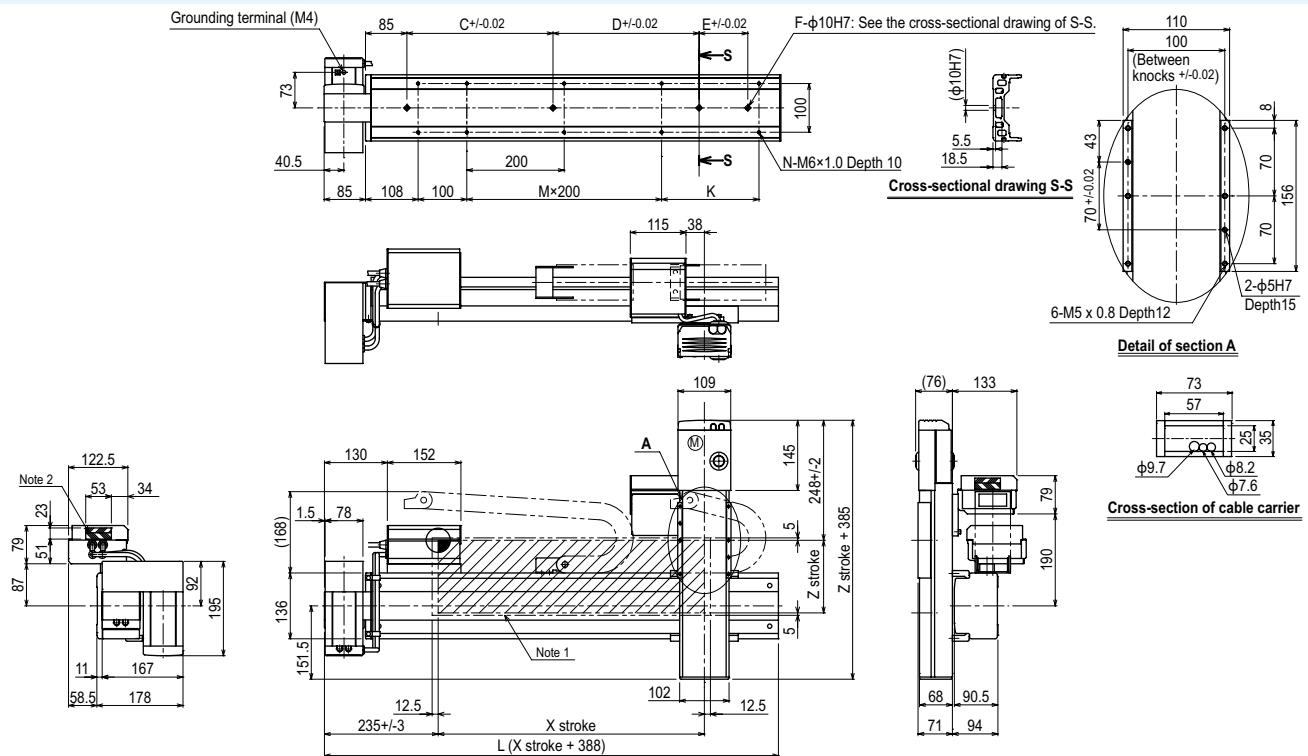

Note 1. The moving range when returning to origin and the stop position when stopping by the mechanical stopper.
 Note 2. The shaded position indicates an user cable extraction port.
 Note 3. LU specification should be used for installation of the X axis motor.

X stroke	150	250	350	450	550	650	750	850	950	1050	1150	1250	1350	1450	1550	1650	1750	1850	1950	2050	2150	2250	2350	2450	2550	2650	2750	2850	2950	3050	
L	538	638	738	838	938	1038	1138	1238	1338	1438	1538	1638	1738	1838	1938	2038	2138	2238	2338	2438	2538	2638	2738	2838	2938	3038	3138	3238	3338	3438	
K	-	100	200	100	200	100	200	100	200	100	200	100	200	100	200	100	200	100	200	100	200	100	200	100	200	100	200	100	200	100	200
C	240	420	420	600	600	780	780	960	1140	1140	1140	1140	1140	1140	1140	1140	1140	1140	1140	1140	1140	1140	1140	1140	1140	1140	1140	1140	1140	1140	1140
D	-	-	-	-	-	-	-	-	-	-	-	240	240	420	600	600	780	780	960	960	1140	1140	1140	1140	1140	1140	1140	1140	1140	1140	1140
E	-	-	-	-	-	-	-	-	-	-	-	-	-	-	-	-	-	-	-	-	-	-	240	240	420	420	600	600	780	960	
F	2	2	2	2	2	2	2	2	2	2	2	3	3	3	3	3	3	3	3	3	3	3	3	3	3	3	3	3	3	3	3
M	1	1	1	2	2	3	3	4	4	5	5	6	6	7	7	8	8	9	9	10	10	11	11	12	12	13	13	14	14	15	
N	6	8	8	10	10	12	12	14	14	16	16	18	18	20	20	22	22	24	24	26	26	28	28	30	30	32	32	34	34	36	
Z stroke	150	250	350																												

Articulated robots
YA
Linear conveyor modules
LCM100
Motor-less single axis actuator
Robonity
Compact single-axis robots
TRANSEVO
Single-axis robots
FLIP-X
Linear motor single-axis robots
PHASER
Cartesian robots
XY-X
SCARA robots
YK-X
Pick & place robots
YP-X
CLEAN
CONTROLLER INFORMATION
Arm type
Gantry type
Moving arm type
Pole type
XZ type