

MXYx

2 axes / ZFL10

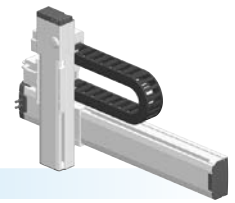

- XZ type
- Cable carrier
- Z-axis: clamped base / moving table type (200W)

Ordering method

MXYx - C [] [] **ZFL10** [] [] **RCX320-2** [] **R** [] [] [] [] [] []

Model	Cable	Combination	X-axis stroke	ZR-axis	Z-axis stroke	Cable
F1			15 to 105cm		15 to 35cm	3L: 3.5m 5L: 5m 10L: 10m
F3						

Controller / Number of controllable axes: RCX320-2
Safety standard: []
Regenerative unit: R
Option A (OP.A): []
Option B (OP.B): []
Vision System: []
Absolute battery: []

Specify various controller setting items. RCX320 ▶ P.548

RCX222 [] **R** [] [] [] [] []

Controller	Usable for CE	Regenerative unit	I/O selection 1	I/O selection 2
RCX222	[]	[]	[]	[]

Specify various controller setting items. RCX222 ▶ P.558

Specification

	X-axis	Z-axis
Axis construction ^{Note 1}	F14H	F10H-BK
AC servo motor output (W)	200	200
Repeatability ^{Note 2} (mm)	+/-0.01	+/-0.01
Drive system	Ball screw φ15	Ball screw φ15
Ball screw lead ^{Note 3} (Deceleration ratio) (mm)	20	10
Maximum speed ^{Note 4} (mm/sec)	1200	600
Moving range (mm)	150 to 1050	150 to 350
Robot cable length (m)	Standard: 3.5 Option: 5, 10	

- Note 1. Use caution that the flange machining (installation holes, tap holes) differs from single-axis robots.
 Note 2. Positioning repeatability in one direction.
 Note 3. Leads not listed in the catalog are also available. Contact us for details.
 Note 4. When the X-axis stroke is longer than 750mm, resonance of the ball screw may occur depending on the operation conditions (critical speed). In this case, reduce the speed setting on the program by referring to the maximum speeds shown in the table below.

Maximum payload (kg)

X stroke (mm)	Z stroke (mm)
150 to 1050	150 to 350
	15

Controller

Controller	Operation method
RCX320-R	Programming / I/O point trace / Remote command / Operation using RS-232C communication
RCX222-R	

MXYx 2 axes / ZFL10 (F1)

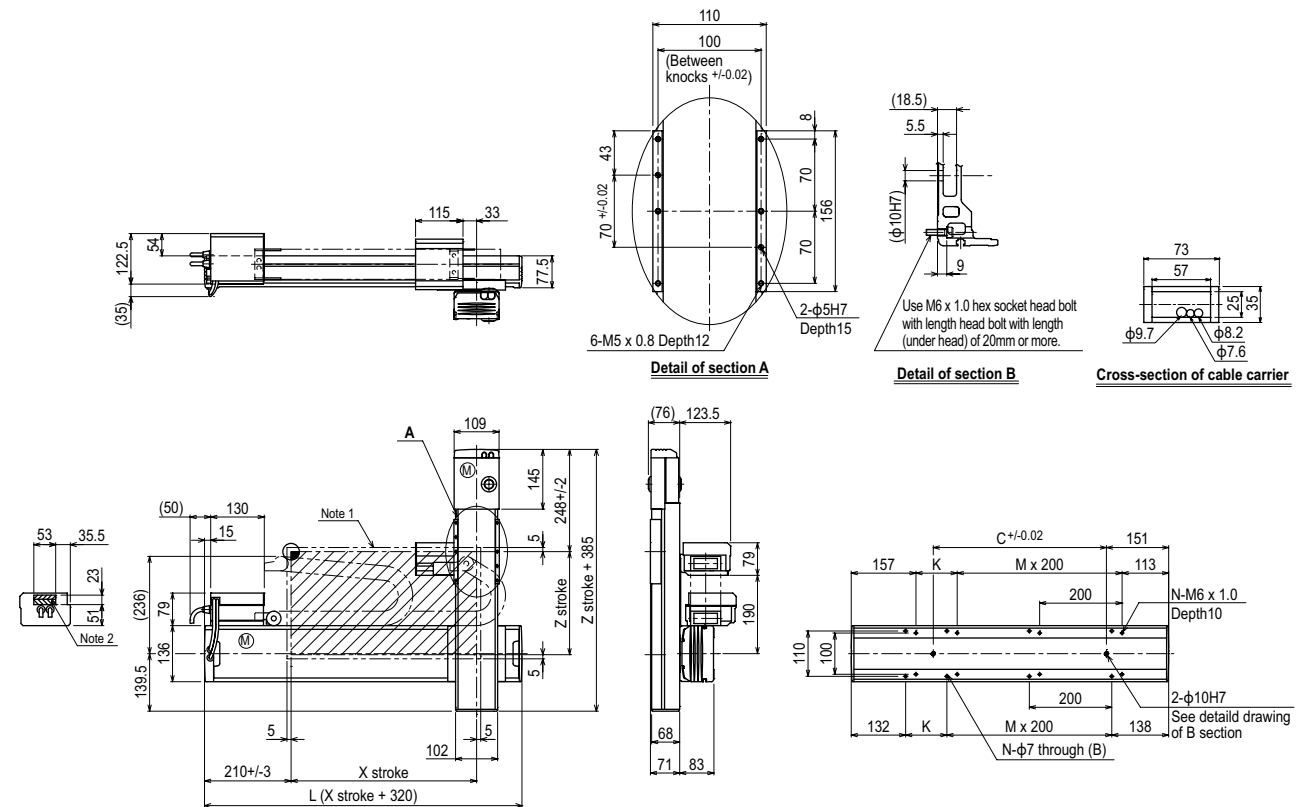

X stroke	150	250	350	450	550	650	750	850	950	1050			
L	470	570	670	770	870	970	1070	1170	1270	1370			
K	200	100	200	100	200	100	200	100	200	100			
C	240	240	420	420	600	600	780	960	960	1140			
M	0	1	1	2	2	3	3	4	4	5			
N	4	6	6	8	8	10	10	12	12	14			
Z stroke	150	250	350										
Maximum speed for each stroke (mm/sec) ^{Note 3}	X-axis		1200			960		780		600		540	
Speed setting			-			80%		65%		50%		45%	