

# SXYx 2 axes

● Pole type ● Whipover



## Ordering method

**SXYx - S - P1**

Model	Cable	Combination	X-axis stroke <sup>Note 1</sup>	Y-axis stroke <sup>Note 1</sup>	Cable
			15 to 85cm	15 to 55cm	3L: 3.5m 5L: 5m 10L: 10m

**RCX320-2**

Controller / Number of controllable axes	Safety standard	Option A (OP.A)	Option B (OP.B)	Vision System	Absolute battery
--	-----------------	-----------------	-----------------	---------------	------------------

Specify various controller setting items. RCX320 ▶ **P.548**

**RCX222**

Controller	Usable for CE	I/O selection 1	I/O selection 2
------------	---------------	-----------------	-----------------

Specify various controller setting items. RCX222 ▶ **P.558**

Note 1. The total of the X and Y strokes should be 1100mm or less.

## Specification

	X-axis	Y-axis
<b>Axis construction</b> <sup>Note 1</sup>	F14H	F14-BK
<b>AC servo motor output (W)</b>	200	100
<b>Repeatability</b> <sup>Note 2</sup> (mm)	+/-0.01	+/-0.01
<b>Drive system</b>	Ball screw φ15	Ball screw φ15
<b>Ball screw lead</b> <sup>Note 3</sup> (Deceleration ratio) (mm)	20	10
<b>Maximum speed</b> <sup>Note 4</sup> (mm/sec)	1200	600
<b>Moving range (mm)</b>	150 to 850	150 to 550
<b>Robot cable length (m)</b>	Standard: 3.5 Option: 5,10	

Note 1. Use caution that the flange machining (installation holes, tap holes) differs from single-axis robots'.  
 Note 2. Positioning repeatability in one direction.  
 Note 3. Leads not listed in the catalog are also available. Contact us for details.  
 Note 4. When the X-axis stroke is longer than 750mm, resonance of the ball screw may occur depending on the operation conditions (critical speed). In this case, reduce the speed setting on the program by referring to the maximum speeds shown in the table below.

## Maximum payload (kg)

Y stroke (mm)	XY 2 axes
150 to 550	8

## Controller

Controller	Operation method
RCX320 RCX222	Programming / I/O point trace / Remote command / Operation using RS-232C communication

## SXYx 2 axes P1

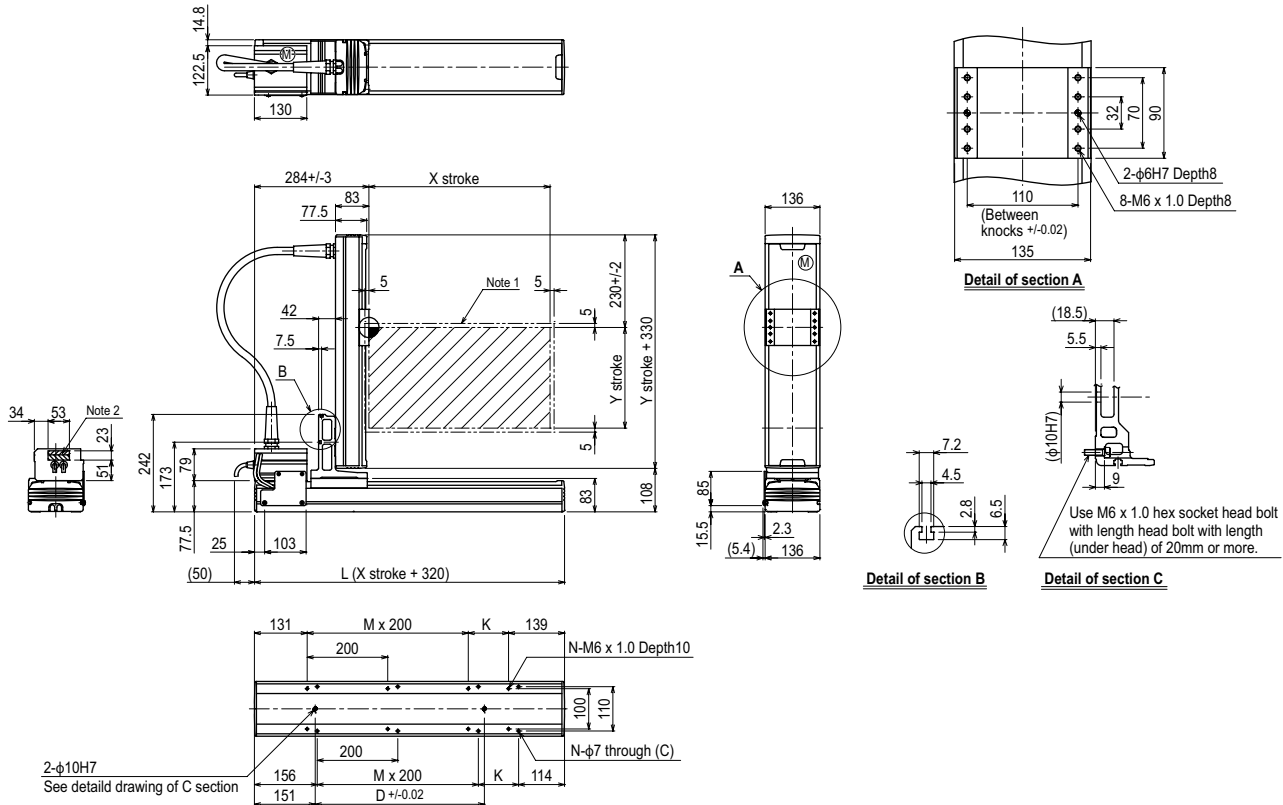

X stroke <sup>Note 3</sup>	150	250	350	450	550	650	750	850
<b>L</b>	470	570	670	770	870	970	1070	1170
<b>K</b>	200	100	200	100	200	100	200	100
<b>D</b>	240	240	420	420	600	600	780	780
<b>M</b>	0	1	1	2	2	3	3	4
<b>N</b>	4	6	6	8	8	10	10	12
Y stroke <sup>Note 3</sup>	150	250	350	450	550			
<b>Maximum speed for each stroke (mm/sec)</b> <sup>Note 4</sup>	X-axis		1200			960		780
<b>Speed setting</b>			-			80%		65%

Note 1. The moving range when returning to origin and the stop position when stopping by the mechanical stopper.  
 Note 2. The shaded position indicates a user cable extraction port.

Note 3. The total of the X and Y strokes should be 1100mm or less.  
 Note 4. When the X-axis stroke is longer than 750mm, resonance of the ball screw may occur depending on the operation conditions (critical speed). In this case, reduce the speed setting on the program by referring to the maximum speeds shown in the table at the left.