

HXYx 2 axes

● Pole type ● Cable carrier

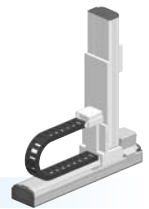

Ordering method

HXYx - C - P2 **RCX320-2** **R**

Model	Cable	Combination	X-axis stroke 25 to 125cm	Y-axis stroke 25 to 105cm	Cable 3L: 3.5m 5L: 5m 10L: 10m	Controller / Number of controllable axes	Safety standard	Regenerative unit	Option A (OP.A)	Option B (OP.B)	Vision System	Absolute battery
-------	-------	-------------	------------------------------	------------------------------	---	--	-----------------	-------------------	-----------------	-----------------	---------------	------------------

Specify various controller setting items. RCX320 ▶ **P.548**

RCX222HP **R**

Controller	Usable for CE	Regenerative unit	I/O selection 1	I/O selection 2
------------	---------------	-------------------	-----------------	-----------------

Specify various controller setting items. RCX222 ▶ **P.558**

Specification

	X-axis	Y-axis
Axis construction ^{Note 1}	F20	F20-BK
AC servo motor output (W)	600	600
Repeatability ^{Note 2} (mm)	+/-0.01	+/-0.01
Drive system	Ball screw φ20	Ball screw φ20
Ball screw lead ^{Note 3} (Deceleration ratio) (mm)	20	10
Maximum speed ^{Note 4} (mm/sec)	1200	600
Moving range (mm)	250 to 1250	250 to 1050
Robot cable length (m)	Standard: 3.5 Option: 5, 10	

Note 1. Use caution that the flame machining (installation holes, tap holes) differs from single-axis robots.
 Note 2. Positioning repeatability in one direction.
 Note 3. Leads not listed in the catalog are also available. Contact us for details.
 Note 4. When the X-axis/Y-axis stroke is longer than 850mm, resonance of the ball screw may occur depending on the operation conditions (critical speed). In this case, reduce the speed setting on the program by referring to the maximum speeds shown in the table below.

Maximum payload (kg)

Y stroke (mm)	XY 2 axes
250 to 1050	30

Controller

Controller	Operation method
RCX320-R	Programming / I/O point trace / Remote command / Operation using RS-232C communication
RCX222HP-R	Programming / I/O point trace / Remote command / Operation using RS-232C communication

HXYx 2 axes P2

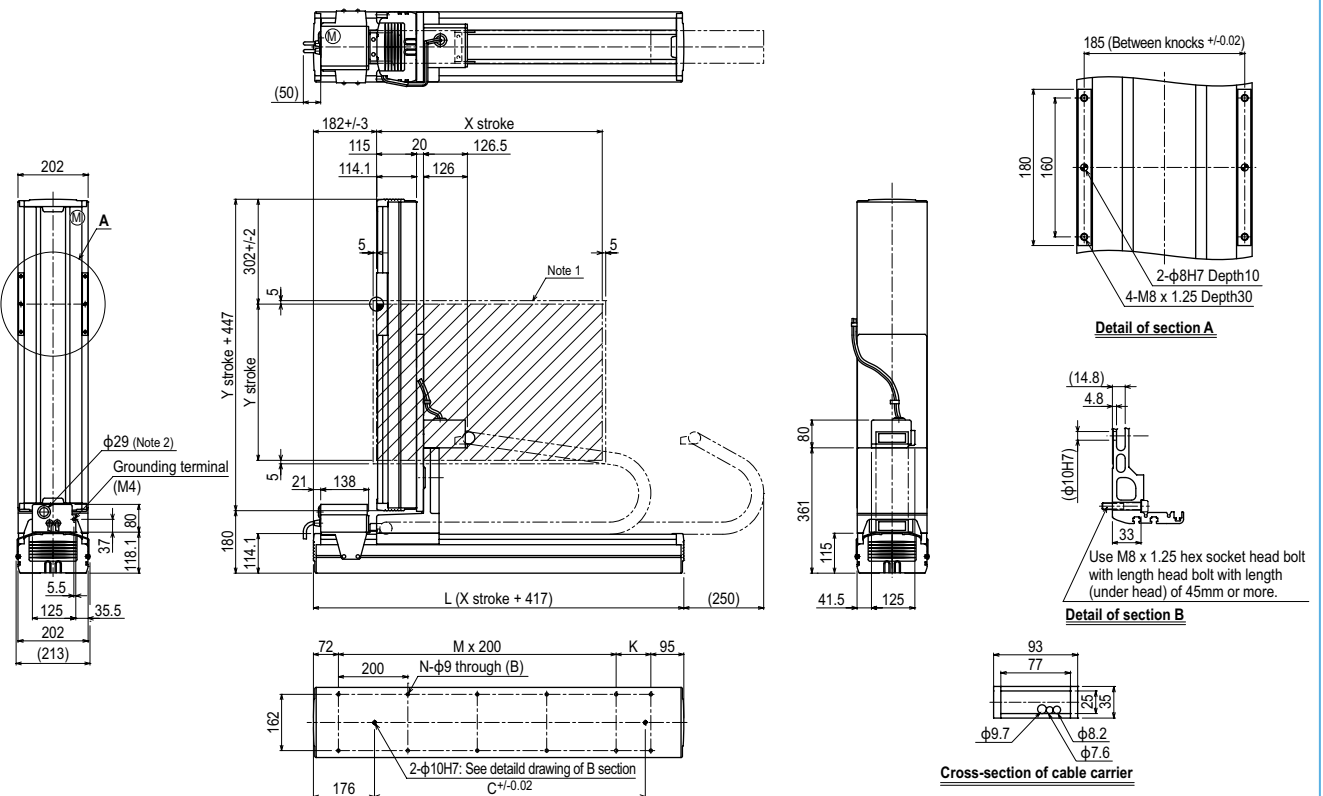

X stroke	250	350	450	550	650	750	850	950	1050	1150	1250
L	667	767	867	967	1067	1167	1267	1367	1467	1567	1667
K	100	200	100	200	100	200	100	200	100	200	100
C	420	420	600	600	780	708	960	960	1140	1320	1320
M	2	2	3	3	4	4	5	5	6	6	7
N	8	8	10	10	12	12	14	14	16	16	18
Y stroke	250	350	450	550	650	750	850	950	1050		
Maximum speed for each stroke (mm/sec) ^{Note 3}	X-axis			1200			960	840	720	600	480
	Y-axis			600			480	420	360		
Speed setting				-			80%	70%	60%	50%	40%

Note 1. The moving range when returning to origin and the stop position when stopping by the mechanical stopper.
 Note 2. User cable extraction port.

Note 3. When the X-axis/Y-axis stroke is longer than 850mm, resonance of the ball screw may occur depending on the operation conditions (critical speed). In this case, reduce the speed setting on the program by referring to the maximum speeds shown in the table at the left.