

HXYx

4 axes / ZRL

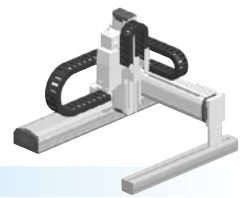

- Gantry type
- Cable carrier
- Z-axis: clamped base / moving table type (200W)+R-axis

Ordering method

HXYx - C - **ZRL** - **RCX340-4**

Model	Cable	Combination	X-axis stroke	Y-axis stroke	ZR-axis	Z-axis stroke	Cable	Controller / Number of controllable axes	Safety standard	Option A (OP.A)	Option B (OP.B)	Option C (OP.C)	Option D (OP.D)	Option E (OP.E)	Absolute battery
		G1 G2 G3 G4	25 to 125cm	25 to 105cm		25 to 55cm	3L: 3.5m 5L: 5m 10L: 10m								

Specify various controller setting items. RCX340 ▶ **P.566**

Specification

	X-axis	Y-axis	Z-axis	R-axis
Axis construction <small>Note 1</small>	F20	F17	F14H-BK	R20
AC servo motor output (W)	600	400	200	200
Repeatability <small>Note 2</small> (XYZ: mm) (R: °)	+/-0.01	+/-0.01	+/-0.01	+/-0.0083
Drive system	Ball screw φ20	Ball screw φ20	Ball screw φ15	Harmonic gear
Ball screw lead <small>Note 3</small> (Deceleration ratio) (mm)	20	20	10	(1/50)
Maximum speed <small>Note 4</small> (XYZ: mm/sec) (R: °/sec)	1200	1200	600	360
Moving range (XYZ: mm) (R: °)	250 to 1250	250 to 1050	250 to 550	360
Robot cable length (m)	Standard: 3.5 Option: 5,10			

- Note 1. Use caution that the flame machining (installation holes, tap holes) differs from single-axis robots.
 Note 2. Positioning repeatability in one direction.
 Note 3. Leads not listed in the catalog are also available. Contact us for details.
 Note 4. When the X-axis/Y-axis stroke is longer than 850mm, resonance of the ball screw may occur depending on the operation conditions (critical speed). In this case, reduce the speed setting on the program by referring to the maximum speeds shown in the table below.

Maximum payload (kg)

Y stroke (mm)	Z stroke (mm)
250 to 1050	250 to 550
	12

Controller

Controller	Operation method
RCX340	Programming / I/O point trace / Remote command / Operation using RS-232C communication

HXYx 4 axes / ZRL (G1)

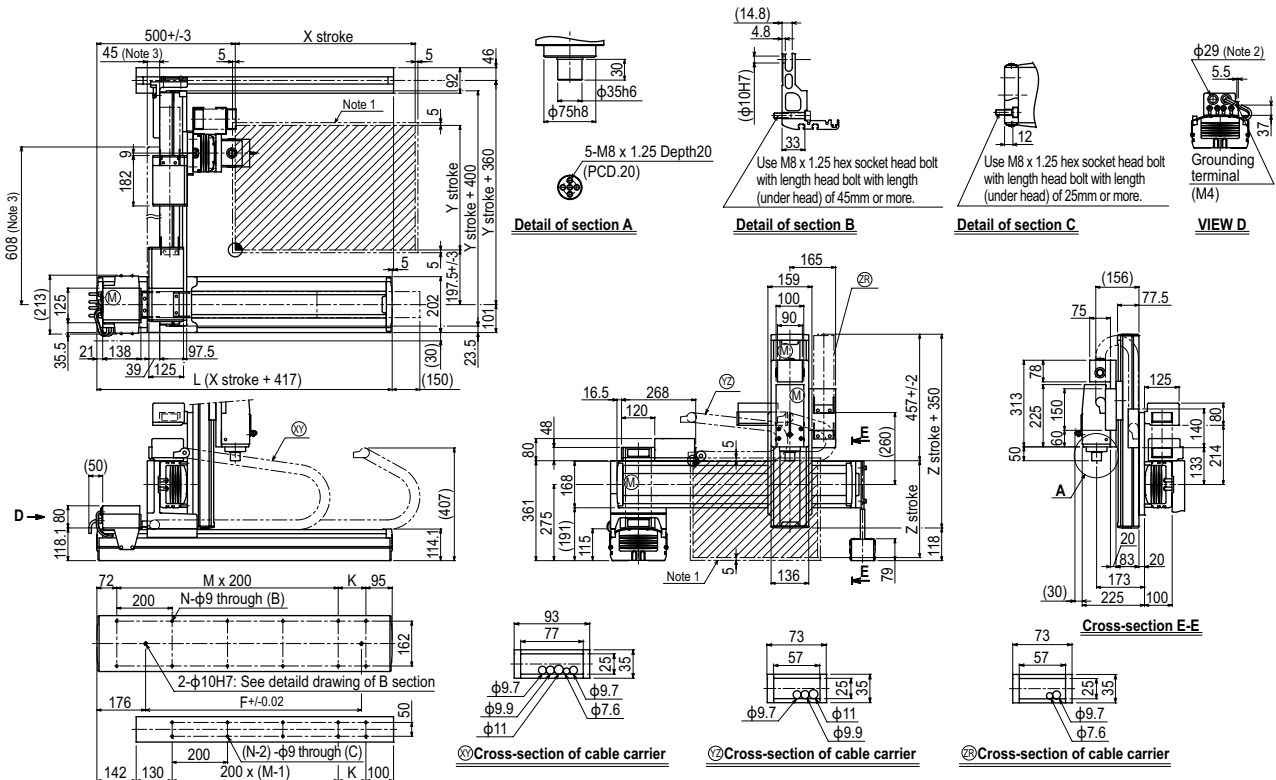

X stroke	250	350	450	550	650	750	850	950	1050	1150	1250
L	667	767	867	967	1067	1167	1267	1367	1467	1567	1667
K	100	200	100	200	100	200	100	200	100	200	100
F	420	420	600	600	780	780	960	960	1140	1320	1320
M	2	2	3	3	4	4	5	5	6	6	7
N	8	8	10	10	12	12	14	14	16	16	18
Y stroke	250	350	450	550	650	750	850	950	1050		
Z stroke	250	350	450	550							
Maximum speed for each stroke (mm/sec) <small>Note 4</small>	X-axis		1200		960		840	720	600	480	
	Y-axis		1200		960		840	720			
	Speed setting		-		80%		70%	60%	50%	40%	

- Note 1. The moving range when returning to origin and the stop position when stopping by the mechanical stopper.
 Note 2. User cable extraction port.
 Note 3. Dimension of reinforced bracket (To be installed when the Y stroke is 750mm or longer)

- Note 4. When the X-axis/Y-axis stroke is longer than 850mm, resonance of the ball screw may occur depending on the operation conditions (critical speed). In this case, reduce the speed setting on the program by referring to the maximum speeds shown in the table at the left.