

# SXYx 4 axes / ZRS

- Arm type
- Whipover
- ZR axis integrated type

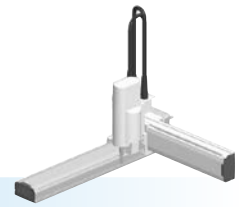

## Ordering method

**SXYx - S** [ ] [ ] [ ] [ ] **15** [ ] **RCX340-4** [ ] [ ] [ ] [ ] [ ] [ ] [ ] [ ] [ ] [ ]

Model	Cable	Combination	X-axis stroke	Y-axis stroke	ZR-axis	Z-axis stroke	Cable	Controller / Number of controllable axes	Safety standard	Option A (OP.A)	Option B (OP.B)	Option C (OP.C)	Option D (OP.D)	Option E (OP.E)	Absolute battery
A1			15 to 85cm	15 to 65cm	ZRS12		3L: 3.5m 5L: 5m 10L: 10m								
A2					ZRS6										
A3															
A4															

Specify various controller setting items. RCX340 ▶ **P.566**

## Specification

	X-axis	Y-axis	Z-axis: ZRS12	Z-axis: ZRS6	R-axis
Axis construction <sup>Note 1</sup>	F14H	F14	-	-	-
AC servo motor output (W)	200	100	60		100
Repeatability <sup>Note 2</sup> (XYZ: mm) (R: °)	+/-0.01	+/-0.01	+/-0.02		+/-0.005
Drive system	Ball screw φ15	Ball screw φ15	Ball screw φ12		Harmonic gear
Ball screw lead <sup>Note 3</sup> (Deceleration ratio) (mm)	20	20	12	6	(1/50)
Maximum speed <sup>Note 4</sup> (XYZ: mm/sec) (R: °/sec)	1200	1200	1000	500	1020
Moving range (XYZ: mm) (R: °)	150 to 850	150 to 650	150		360
Robot cable length (m)	Standard: 3.5 Option: 5,10				

- Note 1. Use caution that the flame machining (installation holes, tap holes) differs from single-axis robots.  
 Note 2. Positioning repeatability in one direction.  
 Note 3. Leads not listed in the catalog are also available. Contact us for details.  
 Note 4. When the X-axis stroke is longer than 750mm, resonance of the ball screw may occur depending on the operation conditions (critical speed). In this case, reduce the speed setting on the program by referring to the maximum speeds shown in the table below.

## Maximum payload (kg)

Y stroke (mm)	ZRS12	ZRS6
150	3	5
250	3	5
350	3	5
450	3	5
550	3	5
650	3	4

## Controller

Controller	Operation method
RCX340	Programming / I/O point trace / Remote command / Operation using RS-232C communication

## SXYx 4 axes / ZRS A1

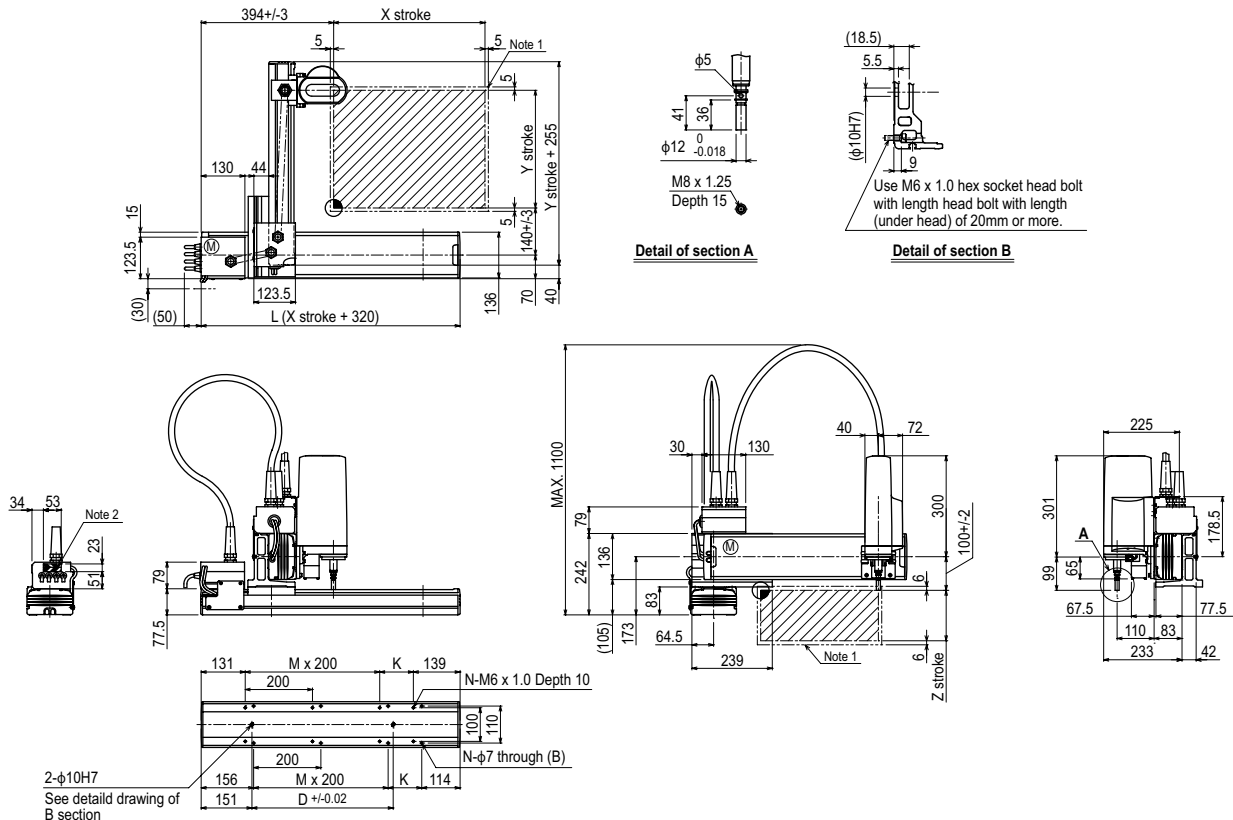

X stroke	150	250	350	450	550	650	750	850	
	L	470	570	670	770	870	970	1070	1170
K	200	100	200	100	200	100	200	100	
D	240	240	420	420	600	600	780	960	
M	0	1	1	2	2	3	3	4	
N	4	6	6	8	8	10	10	12	
Y stroke	150	250	350	450	550	650			
Z stroke	150								
Maximum speed for each stroke (mm/sec) <sup>Note 3</sup>	X-axis		1200				960	780	
	Speed setting		-				80%	65%	

Note 1. The moving range when returning to origin and the stop position when stopping by the mechanical stopper.  
 Note 2. The shaded position indicates a user cable extraction port.

Note 3. When the X-axis stroke is longer than 750mm, resonance of the ball screw may occur depending on the operation conditions (critical speed). In this case, reduce the speed setting on the program by referring to the maximum speeds shown in the table at the left.

Articulated robots  
YA  
Linear conveyor modules  
LCM100  
Motor-less single axis actuator  
Robonity  
Compact single-axis robots  
TRANSEVO  
Single-axis robots  
FLIP-X  
Linear motor single-axis robots  
PHASER  
Cartesian robots  
XY-X  
SCARA robots  
YK-X  
Pick & place robots  
YP-X  
CLEAN  
CONTROLLER INFORMATION  
Arm type  
Gantry type  
Moving arm type  
Pole type  
XZ type