

# PXYx 2 axes

● Arm type ● Cable carrier



## Ordering method

### PXYx - C

Model	Cable	Combination	X-axis stroke	Y-axis stroke	Cable
A1			15 to 65cm	5 to 30cm	3L: 3.5m
A2					5L: 5m
A3					10L: 10m
A4					

### RCX320-2

Controller / Number of controllable axes	Safety standard	Option A (OP.A)	Option B (OP.B)	Vision System	Absolute battery

Specify various controller setting items. RCX320 ▶ P.548

### RCX222

Controller	Usable for CE	I/O selection 1	I/O selection 2

Specify various controller setting items. RCX222 ▶ P.558

## Specification

	X-axis	Y-axis
Axis construction <sup>Note 1</sup>	-	T4H
AC servo motor output (W)	60	30
Repeatability <sup>Note 2</sup> (mm)	+/-0.02	+/-0.02
Drive system	Ball screw φ12	Ball screw φ8
Ball screw lead <sup>Note 3</sup> (Deceleration ratio) (mm)	12	12
Maximum speed <sup>Note 4</sup> (mm/sec)	720	720
Moving range (mm)	150 to 650	50 to 300
Robot cable length (m)	Standard: 3.5 Option: 5,10	

Note 1. Use caution that the flame machining (installation holes, tap holes) differs from single-axis robots.  
 Note 2. Positioning repeatability in one direction.  
 Note 3. Leads not listed in the catalog are also available. Contact us for details.  
 Note 4. When the X-axis stroke is longer than 650mm, resonance of the ball screw may occur depending on the operation conditions (critical speed). In this case, reduce the speed setting on the program by referring to the maximum speeds shown in the table below.

## Maximum payload (kg)

Y stroke (mm)	XY 2 axes
50	4.5
100	4.5
150	3.5
200	2.5
250	2
300	1.5

## Controller

Controller	Operation method
RCX320	Programming / I/O point trace / Remote command / Operation using RS-232C communication
RCX222	

## PXYx 2 axes A1

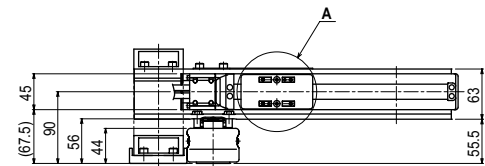
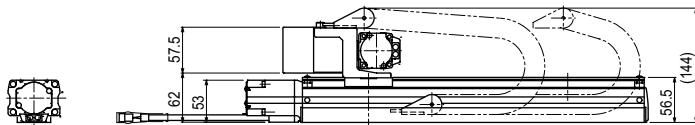
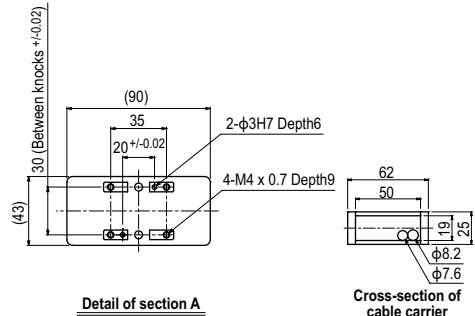
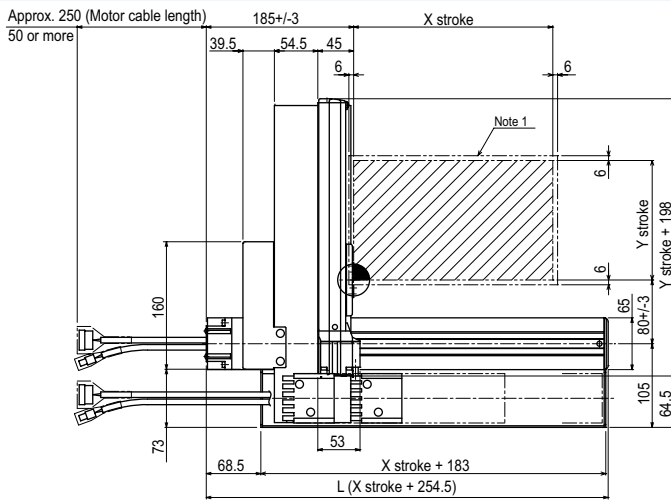

Use M4 x 0.7 hex socket head bolt with length head bolt with length (under head) of 15mm or more.

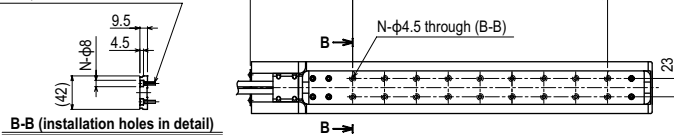

X stroke	150	250	350	450	550	650
L	404.5	504.5	604.5	704.5	804.5	904.5
M	5	8	10	13	15	18
N	12	18	22	28	32	38
Y stroke	50	100	150	200	250	300
Maximum speed for each stroke (mm/sec) <sup>Note 2</sup>	X-axis					600
Speed setting	-					83%

Note 1. The moving range when returning to origin and the stop position when stopping by the mechanical stopper.

Note 2. When the X-axis stroke is longer than 650mm, resonance of the ball screw may occur depending on the operation conditions (critical speed). In this case, reduce the speed setting on the program by referring to the maximum speeds shown in the table at the left.

Articulated robots
YA
Linear conveyor modules
LCM100
Motor-less single axis actuator
Robonity
Compact single-axis robots
TRANSEVO
Single-axis robots
FLIP-X
Linear motor single-axis robots
PHASER
Cartesian robots
XY-X
SCARA robots
YK-X
Pick & place robots
YP-X
CLEAN
CONTROLLER
INFORMATION
Arm type
Gantry type
Moving arm type
Pole type
XZ type

PXYx 2 axes **A2**

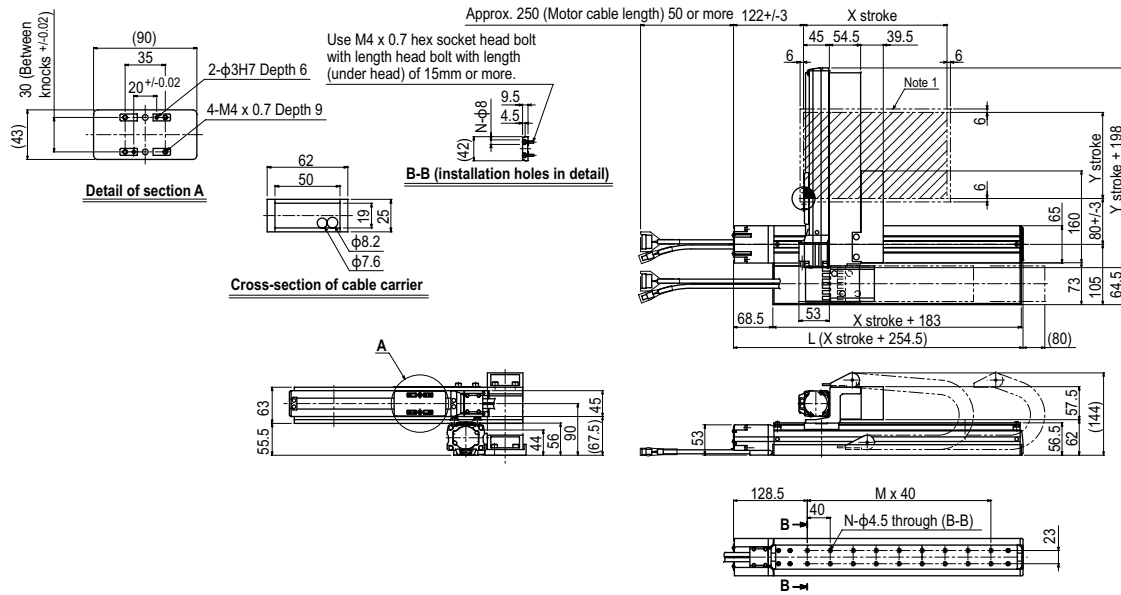

PXYx 2 axes **A3**

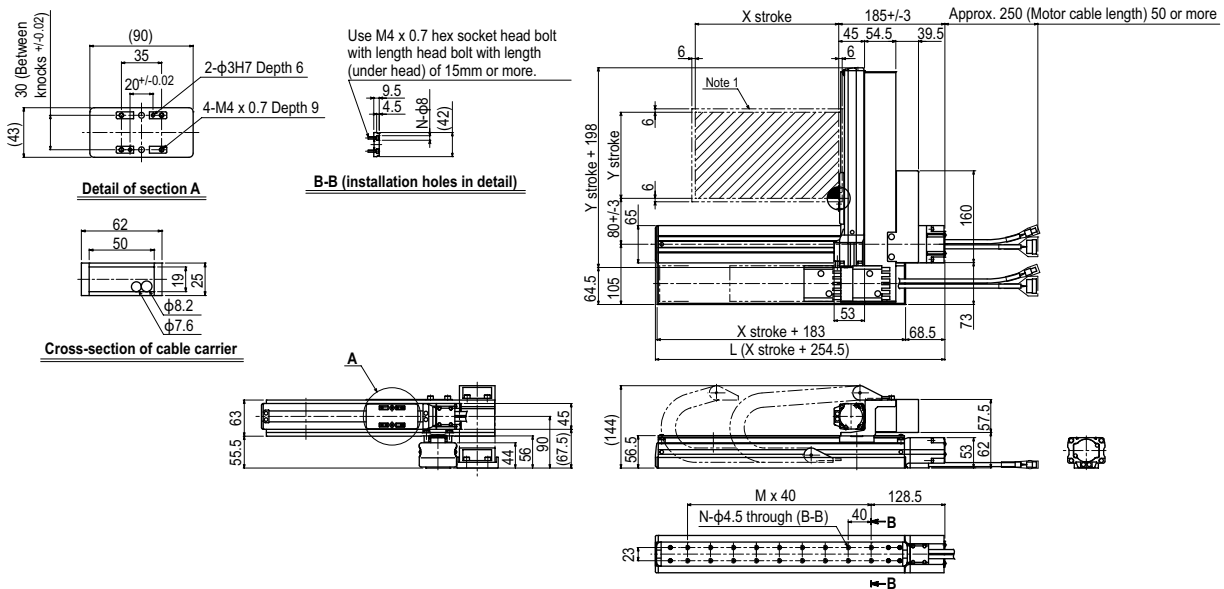

PXYx 2 axes **A4**

