

- Arm type
- Cable carrier
- Z-axis clamped table: moving base type (200W)

Ordering method

NXY - C [] [] [] **ZFH** [] [] **RCX340-3** [] [] [] [] [] [] [] [] [] [] [] [] [] [] []

Model	Cable	Combination	X-axis stroke	Y-axis stroke	ZR-axis	Z-axis stroke	Cable	Controller / Number of controllable axes	Safety standard	Option A (OP.A)	Option B (OP.B)	Option C (OP.C)	Option D (OP.D)	Option E (OP.E)	Absolute battery
		A1 A3	50 to 200cm	15 to 65cm		15 to 35cm	3L: 3.5m 5L: 5m 10L: 10m								

Specify various controller setting items. RCX340 ▶ **P.566**

Specification

	X-axis	Y-axis	Z-axis
Axis construction <small>Note 1</small>	N15	F14	F10H-BK
AC servo motor output (W)	400	100	200
Repeatability <small>Note 2</small> (mm)	+/-0.01	+/-0.01	+/-0.01
Drive system	Ball screw φ15	Ball screw φ15	Ball screw φ15
Ball screw lead <small>Note 3</small> (Deceleration ratio) (mm)	20	20	10
Maximum speed (mm/sec)	1200	1200	600
Moving range (mm)	500 to 2000	150 to 650	150 to 350
Robot cable length (m)	Standard: 3.5 Option: 5,10		

Note 1. Use caution that the flame machining (installation holes, tap holes) differs from single-axis robots.
 Note 2. Positioning repeatability in one direction.
 Note 3. Leads not listed in the catalog are also available. Contact us for details.

Maximum payload (kg)

Y stroke (mm)	Z stroke (mm)			
	150	250	350	650
150	13	13	12	12
250	12	11	10	10
350	10	9	8	8
450	8	7	6	6
550	5	4	3	3
650	3	2	1	1

Controller

Controller	Operation method
RCX340	Programming / I/O point trace / Remote command / Operation using RS-232C communication

NXY 3 axes / ZFH (A1)

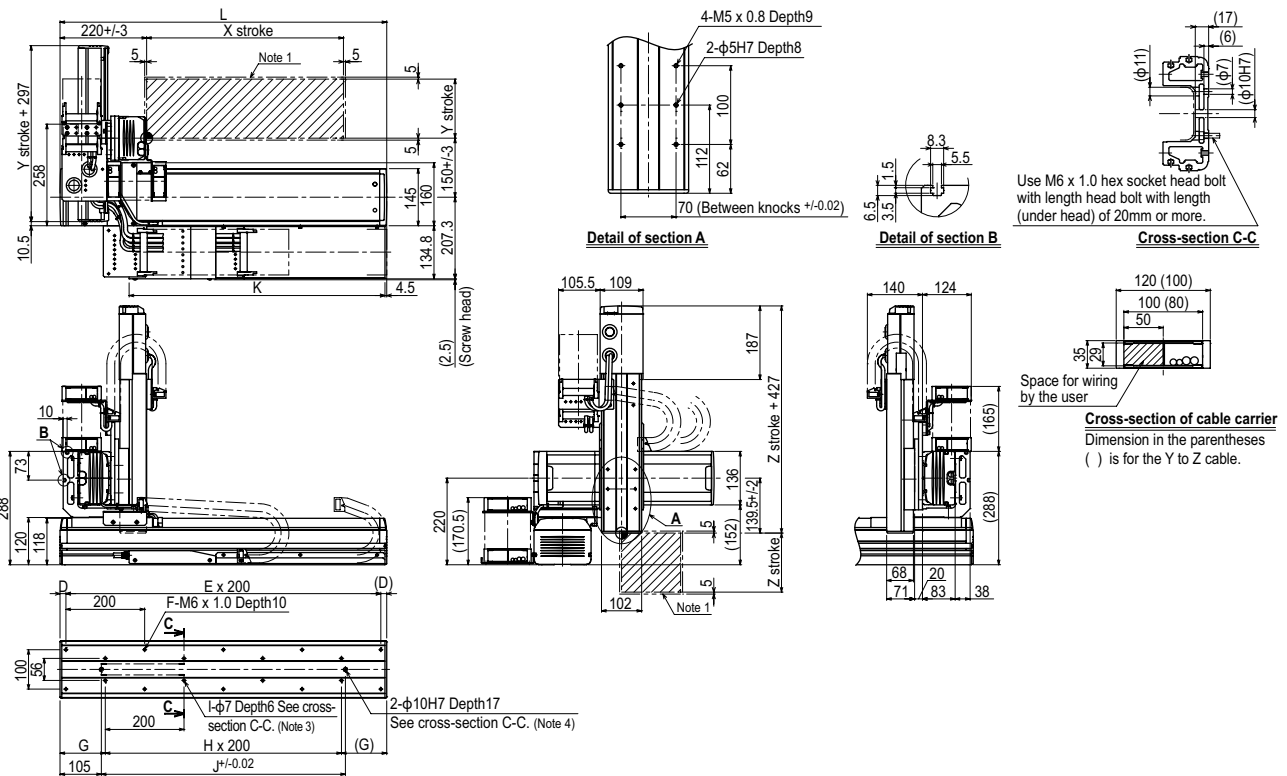

Note 1. The moving range when returning to origin and the stop position when stopping by the mechanical stopper.
 Note 2. The origin of the X axis is set originally as the drawing and it is possible to change it to the R side origin by changing parameters.
 Note 3. When using φ7 holes for installation, you must not use a washer, spring washer, etc. in the main unit.
 Note 4. When using a φ10H7 hole, make sure that the pin does not go into deeper than as shown in the drawing.
 Note 5. Use M4 tap of the box next to X axis for the user grounding terminal.
 Note 6. The M4 taps at both ends of the cable carriage can be used for fixing cables.

NXY 3 axes / ZFH **A3**

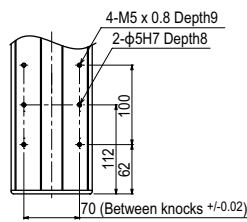

Detail of section A

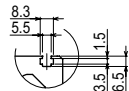

Detail of section B

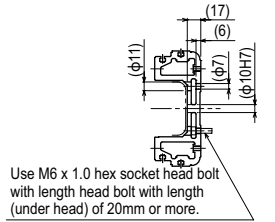

Cross-section C-C

Use M6 x 1.0 hex socket head bolt with length head bolt with length (under head) of 20mm or more.

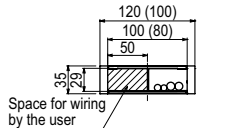

Cross-section of cable carrier
Dimension in the parentheses () is for the Y to Z cable.

Space for wiring by the user

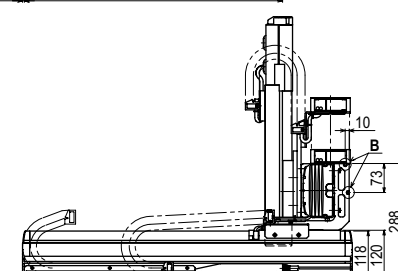
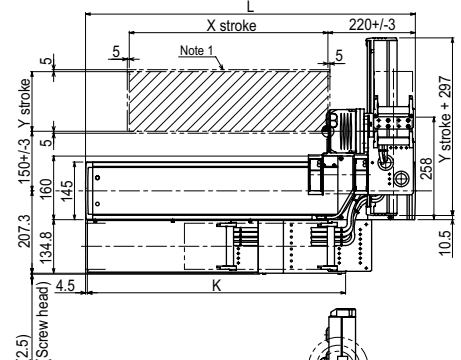
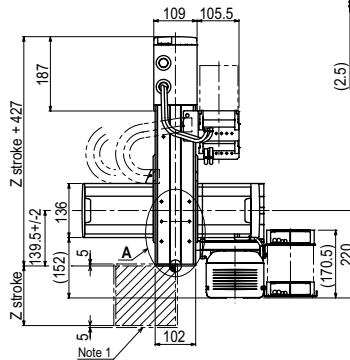
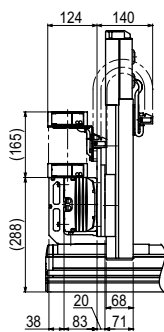

2-φ10H7 Depth17
See cross-section C-C. (Note 4)

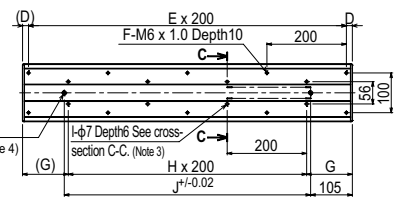

X stroke	500	600	700	800	900	1000	1100	1200	1300	1400	1500	1600	1700	1800	1900	2000
L	830	930	1030	1130	1230	1330	1430	1530	1630	1730	1830	1930	2030	2130	2230	2330
D	15	65	15	65	15	65	15	65	15	65	15	65	15	65	15	65
E	4	4	5	5	6	6	7	7	8	8	9	9	10	10	11	11
F	10	10	12	12	14	14	16	16	18	18	20	20	22	22	24	24
G	115	165	115	165	115	165	115	165	115	165	115	165	115	165	115	165
H	3	3	4	4	5	5	6	6	7	7	8	8	9	9	10	10
I	8	8	10	10	12	12	14	14	16	16	18	18	20	20	22	22
J	620	720	820	920	1020	1120	1220	1320	1420	1520	1620	1720	1820	1920	2020	2120
K	650	700	750	800	850	900	950	1000	1050	1100	1150	1200	1250	1300	1350	1400
Y stroke	150	250	350	450	550	650										
Z stroke	150	250	350													

- Note 1. The moving range when returning to origin and the stop position when stopping by the mechanical stopper.
- Note 2. The origin of the X axis is set originally as the drawing and it is possible to change it to the R side origin by changing parameters.
- Note 3. When using φ7 holes for installation, you must not use a washer, spring washer, etc. in the main unit.
- Note 4. When using a φ10H7 hole, make sure that the pin does not go into deeper than as shown in the drawing.
- Note 5. Use M4 tap of the box next to X axis for the user grounding terminal.
- Note 6. The M4 taps at both ends of the cable carriage can be used for fixing cables.