

STH04

Slide table type

- CE compliance
- Origin on the non-motor side is selectable

Ordering method

STH04

Model	Lead	Model	Brake	Origin position	Bracket plate	Stroke	Cable length
	05: 5mm 10: 10mm	S: Straight model R: Space-saving model (motor installed on right) L: Space-saving model (motor installed on left)	N: With no brake B: With brake	N: Standard Z: Non-motor side	N: No plate H: With plate	50: 50mm 100: 100mm	1K: 1m 3K: 3m 5K: 5m 10K: 10m

S2

Robot positioner	I/O
S2: TS-S2	NP: NPN PN: PNP CC: CC-Link DN: DeviceNet™ EP: EtherNet/IP™ PT: PROFINET GW: No I/O board

SH

Robot positioner	I/O	Battery
SH: TS-SH	NP: NPN PN: PNP CC: CC-Link DN: DeviceNet™ EP: EtherNet/IP™ PT: PROFINET GW: No I/O board	B: With battery (Absolute) N: None (Incremental)

SD

Robot driver	I/O cable
SD: TS-SD	1: 1m

- Note 1. For the space saving models (R and L), the specifications with brake are applicable to only 100mm strokes.
 Note 2. If changing from the origin position at the time of purchase, the machine reference amount must be reset. For details, refer to the manual.
 Note 3. Space-saving models (R and L) with the plate cannot be selected.
 Note 4. The robot cable is flexible and resists bending.
 Note 5. See P.522 for DIN rail mounting bracket.
 Note 6. The robot with the brake cannot use the TS-SD.
 Note 7. Select this selection when using the gateway function. For details, see P.66.

Basic specifications

Motor	28 □ Step motor	
Resolution (Pulse/rotation)	4096	
Repeatability (mm)	+/-0.05	
Drive method	Straight	Slide screw
	Space-saving	Slide screw + belt
Ball screw lead (mm)	5 10	
Maximum speed (mm/sec)	200 400	
Maximum payload (kg)	Horizontal	6 4
	Vertical	2 1
Max. pressing force (N)	55 30	
Stroke (mm)	50/100	
Maximum outside dimension of body cross-section (mm)	Straight	W45 × H46
	Space-saving	W74.5 × H51
Cable length (m)	Standard: 1 / Option: 3, 5, 10	

- Note 1. Positioning repeatability in one direction.
 Note 2. The maximum speed needs to be changed in accordance with the payload.
 See the "Speed vs. payload" graph shown on the right. For details, see P. 152.

Allowable overhang

Lead	Horizontal installation (Unit: mm)			Wall installation (Unit: mm)			Vertical installation (Unit: mm)		
	A	B	C	A	B	C	A	C	
Lead 10	2kg	1534	611	435	595	1504	0.5kg	2000	2000
	3kg	949	374	263	359	920	0.75kg	1558	1558
	4kg	656	255	177	241	629	1kg	1165	1164
Lead 5	2kg	1534	611	435	595	1504	1kg	1165	1164
	4kg	656	255	177	241	629	1.5kg	771	771
	6kg	364	137	91	123	337	2kg	574	574

- Note. Overhang at travelling service life of 3000km.
 (Service life is calculated for 75mm stroke models.)

Static loading moment

Stroke	Static loading moment (Unit: N·m)		
	MY	MP	MR
50mm	26	26	48
100mm	43	43	

Motor installation (Space-saving model)

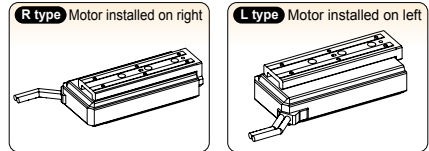

Speed vs. payload

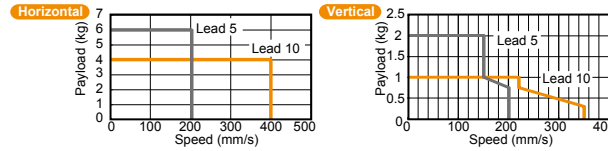

Controller

Controller	Operation method
TS-S2	I/O point trace / Remote command
TS-SH	Remote command
TS-SD	Pulse train control

Note. The robot with the brake cannot use the TS-SD.

STH04 Straight model S

Effective stroke	50	100
B	40	44
C	6	8
D	116.5	191.5
E	65	85
G	39.5	88.5
L	122	191
Weight (kg)	1.25	1.7

Note 1. Return-to-origin position.
 Note 2. Table movable range during return-to-origin operation. The values in [] show those when the return-to-origin direction is changed.
 Note 3. The minimum bending radius of the motor cable is R30.
 Note 4. When installing the mechanical main unit using the back facing holes, use the hex socket head cap M5 bolts.
 Note 5. The installation hole positions of the main unit with the specifications with the brake are common to those shown above.
 Note 6. Models with a brake will be 0.11kg heavier.

STH04 Space-saving model (motor installed on right) **R**

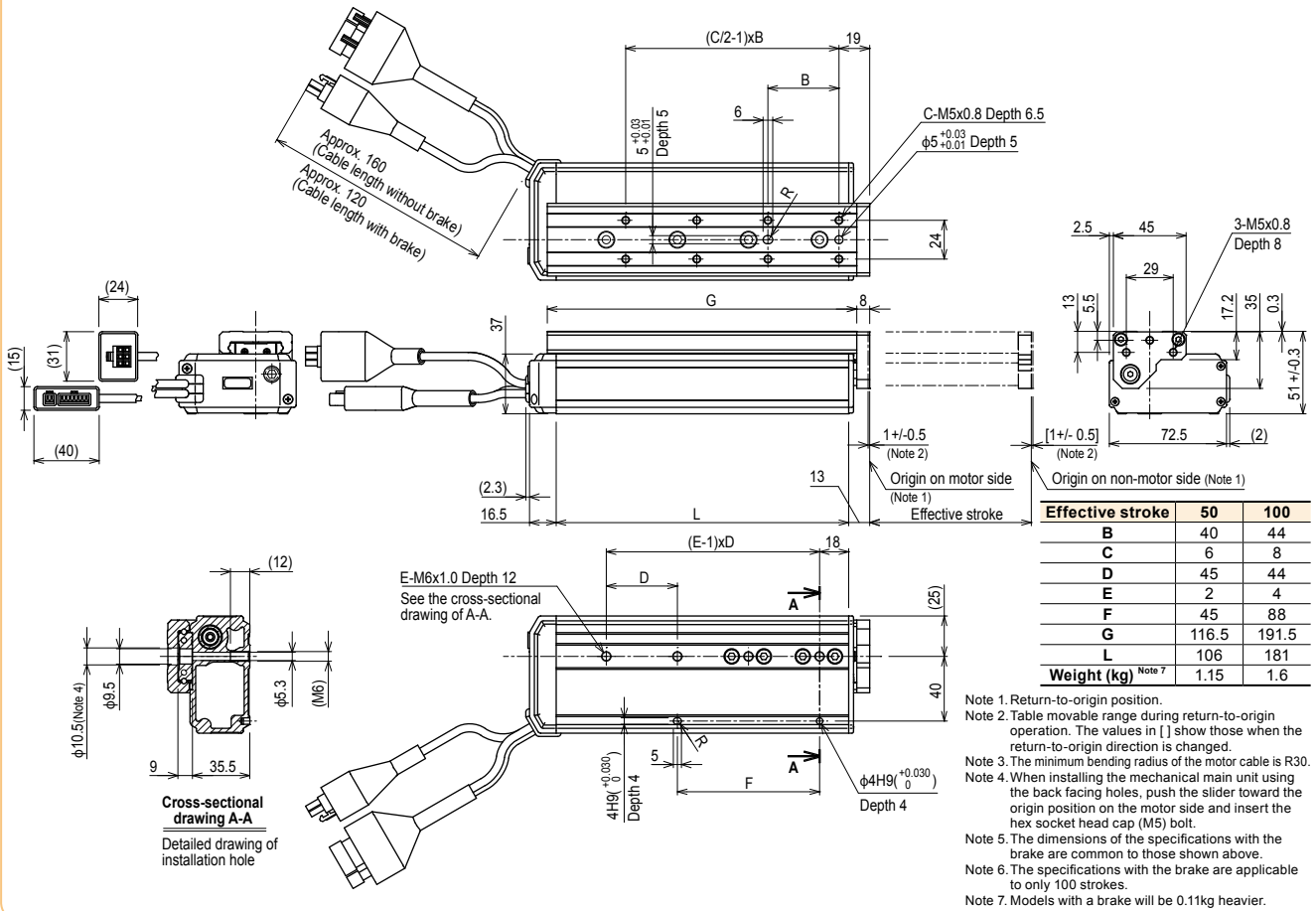

STH04 Space-saving model (motor installed on left) **L**

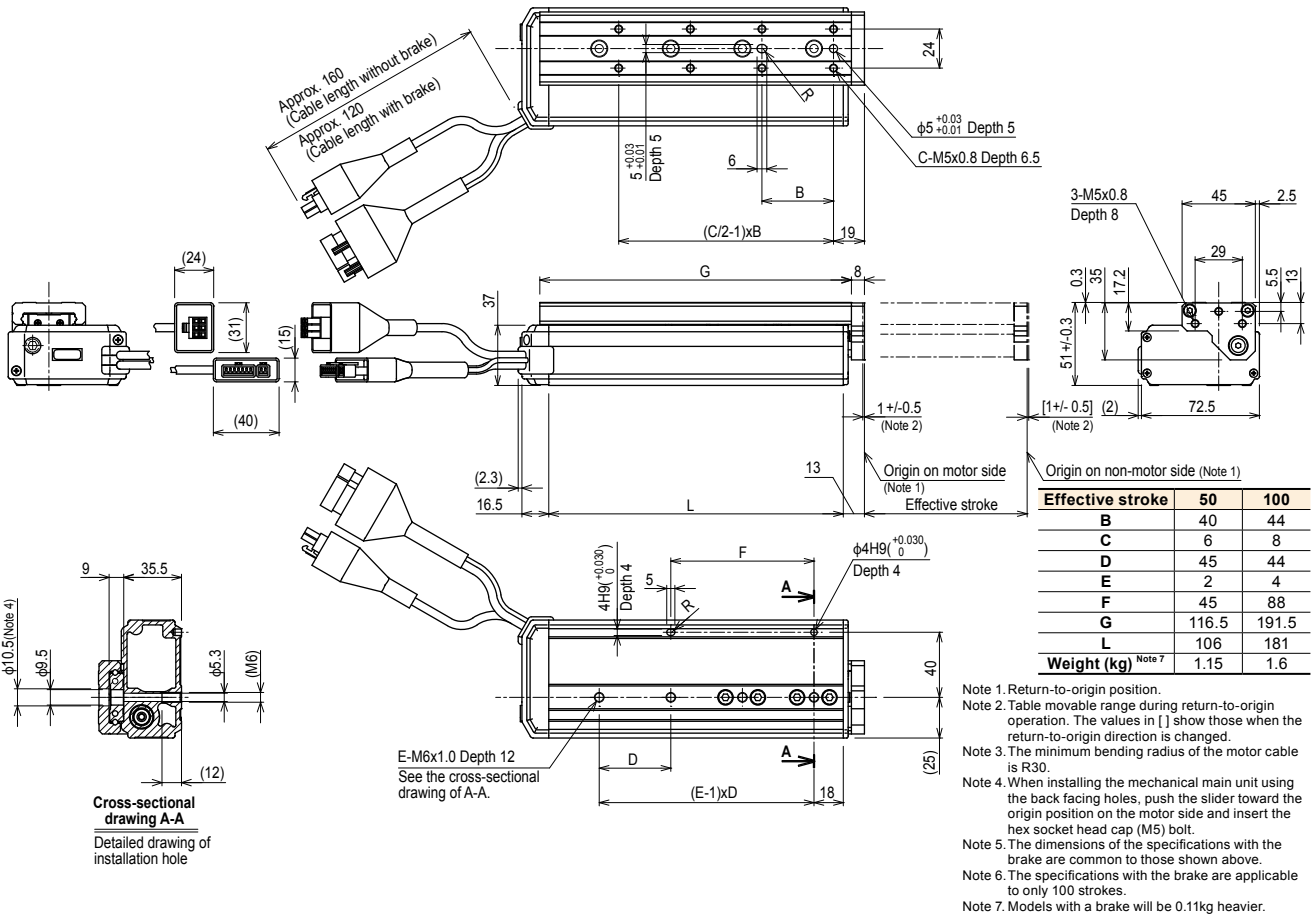

Articulated robots
YA

Linear conveyor modules
LCM100

Motor-assisted axis actuator
Robonity

Compact single-axis robots
TRANSEVO

Single-axis robots
FLIP-X

Linear motor single-axis robots
PHASER

Cartesian robots
XY-X

SCARA robots
YK-X

Pick & place robots
YP-X

CLEAN

CONTROLLER INFORMATION