

AGBS10/AGBS10H

Advanced model

Single-axis robots

Timing Belt Drive type

Ordering method

Model	Lead	Shape	Motor specification	Stroke	Note 1 Cable length	Cable entry location	Robot positioner	Driver: Power capacity	Note 2 Regenerative unit	I/O	Battery Note 3
AGBS10 AGBS10H	50: 50mm (Limited to AGBS10H) 30: 30mm	R: Motor rightward, horizontal position L: Motor leftward, horizontal position RU: Motor rightward, upper position LU: Motor leftward, upper position RD: Motor rightward, lower position LD: Motor leftward, lower position	S: Standard/With no brake BL: Battery-less absolute/ With no brake	150 to 3000 (50mm pitch)	R3: 3m R5: 5m R10: 10m	R: From rear of motor F: From front of motor	EP-01	A10: 200W or less	No entry: None R: With EP-RU	EP: EtherNet/IP™ PT: PROFNET ES: EtherCAT NS: NPN CC: CC-Link	B: With battery N: None

Note 1. The robot cable is flexible and resists bending.

Note 2. [For AGBS10]

When the actuator is used horizontally, the stroke is 2200mm or more, the regenerative unit is needed.

[For AGBS10H]

When the actuator is used horizontally, ①lead 30 is selected, and the stroke is 500mm or more, ②lead 50 is selected, and the stroke is 850mm or more, the regenerative unit is needed.

Note 3. When the motor specification is the standard (S, BK), whether to use the battery needs to be selected.

Note. The return-to-origin direction can be changed by changing the parameter. (The standard is that the origin is located on the motor side. For details about how to change the return-to-origin direction, see the instruction manual for EP-01.)

AGBS10 (100W)

Specifications

AC servo motor output	100 W
Repeatability Note 1	±0.04 mm
Stroke	150 mm to 3000 mm (50 mm pitch)
Maximum Speed Note 2	2250 mm/sec
Belt	Equivalent to 30-mm Lead
Maximum payload	Horizontal 12 kg
Maximum dimensions of cross section of main unit	W 100 mm × H 81 mm
Overall length	L/R Specifications ST + 402.2 mm Other than the above ST + 332.7 mm
Degree of Cleanliness Note 3	Equivalent to ISO Class 3 (ISO 14644-1)
Intake air Note 4	60 Nℓ/min to 70 Nℓ/min Absolute Encoder Batteryless Absolute Encoder
Position detector	
Resolution	23 bits
Using ambient temperature and humidity Note 5	0 to 40 °C, 35 to 80 %RH (no condensation)

Note 1. Positioning repeatability in one direction.

Note 2. When a moving distance is short and depending on an operation condition, it may not reach the maximum speed.

Note 3. When using in a clean environment, attach a suction air joint. The degree of cleanliness is the cleanliness level achieved when using at 1000 mm/sec or less.

Note 4. The required suction amount will vary according to the operating conditions and operating environment.

Note 5. When operating in low-temperature environments, a deviation error may occur when starting from a stopped state. In such cases, reduce the speed to 50% or less and run the unit for at least one full cycle before setting it to the desired operating speed.

AGBS10H (200W)

Specifications

AC servo motor output	200 W
Repeatability Note 1	±0.04 mm
Stroke	150 mm to 3000 mm (50 mm pitch)
Maximum Speed Note 2	3750 mm/sec 2250 mm/sec
Belt	Equivalent to 50-mm Lead Equivalent to 30-mm Lead
Maximum payload	Horizontal 18 kg 35 kg
Maximum dimensions of cross section of main unit	W 100 mm × H 81 mm
Overall length	L/R Specifications ST + 402.2 mm Other than the above ST + 332.7 mm
Degree of Cleanliness Note 3	Equivalent to ISO Class 3 (ISO 14644-1)
Intake air Note 4	60 Nℓ/min to 70 Nℓ/min Absolute Encoder Batteryless Absolute Encoder
Position detector	
Resolution	23 bits
Using ambient temperature and humidity Note 5	0 to 40 °C, 35 to 80 %RH (no condensation)

Note 1. Positioning repeatability in one direction.

Note 2. When a moving distance is short and depending on an operation condition, it may not reach the maximum speed.

Note 3. When using in a clean environment, attach a suction air joint. The degree of cleanliness is the cleanliness level achieved when using at 1000 mm/sec or less.

Note 4. The required suction amount will vary according to the operating conditions and operating environment.

Note 5. When operating in low-temperature environments, a deviation error may occur when starting from a stopped state. In such cases, reduce the speed to 50% or less and run the unit for at least one full cycle before setting it to the desired operating speed.

Motor installation

The line-up consisting of six models of different motor installation position as follows.

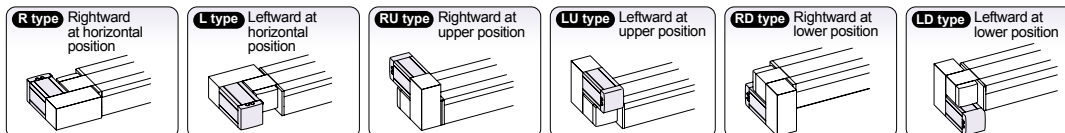

Allowable overhang Note

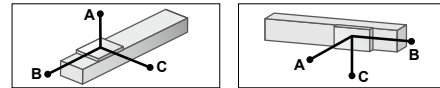

AGBS10-30

	Horizontal installation (Unit: mm)			Wall installation (Unit: mm)		
	A	B	C	A	B	C
6kg	1284	621	522	6kg	570	408 859
9kg	1027	408	376	9kg	387	257 661
12kg	954	305	308	12kg	301	184 594

Note. Distance from center of slider top to center of gravity of object being carried at a guide service life of 10,000 km.

Note. Service life is calculated for 1000 mm stroke models.

Note. When using it suspended from the ceiling, the overhang will be the same as when used horizontally.

Static loading moment

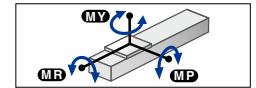

(Unit: N·m)		
MY	MP	MR
186	186	164

Controller

Controller	Operation method
EP-01	I/O point trace/ Remote command

Allowable overhang Note

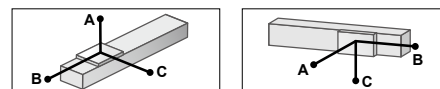

AGBS10H-50

	Horizontal installation (Unit: mm)			Wall installation (Unit: mm)		
	A	B	C	A	B	C
6kg	943	621	429	6kg	479	408 627
12kg	768	302	279	12kg	276	182 477
18kg	746	208	220	18kg	198	115 434

AGBS10H-30

	Horizontal installation (Unit: mm)			Wall installation (Unit: mm)		
	A	B	C	A	B	C
15kg	630	238	223	15kg	211	137 376
25kg	626	152	168	25kg	135	76 336
35kg	648	115	139	35kg	94	50 313

Note. Distance from center of slider top to center of gravity of object being carried at a guide service life of 10,000 km.

Note. Service life is calculated for 1000 mm stroke models.

Note. When using it suspended from the ceiling, the overhang will be the same as when used horizontally.

► The cycle time simulation and service life calculation can be performed easily from our member site.

AGBS10

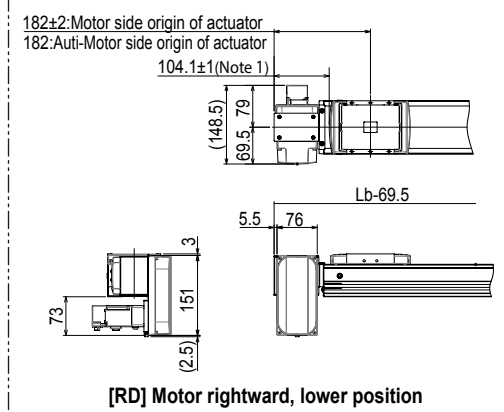
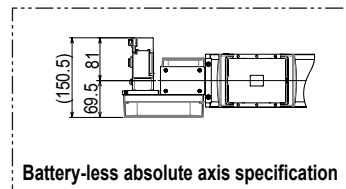
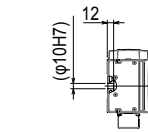
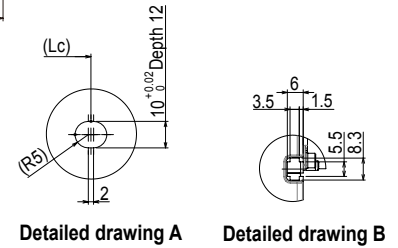
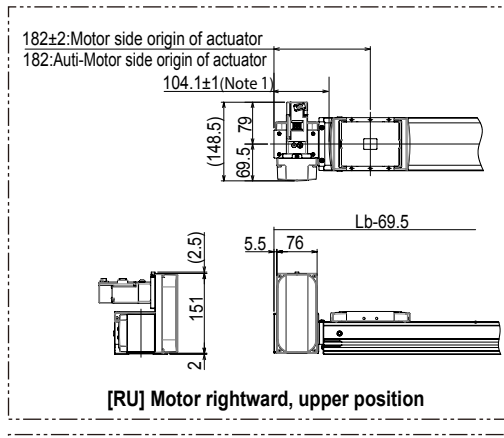
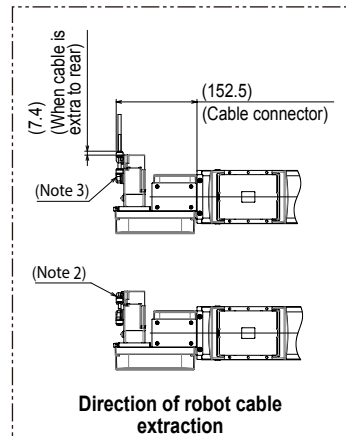
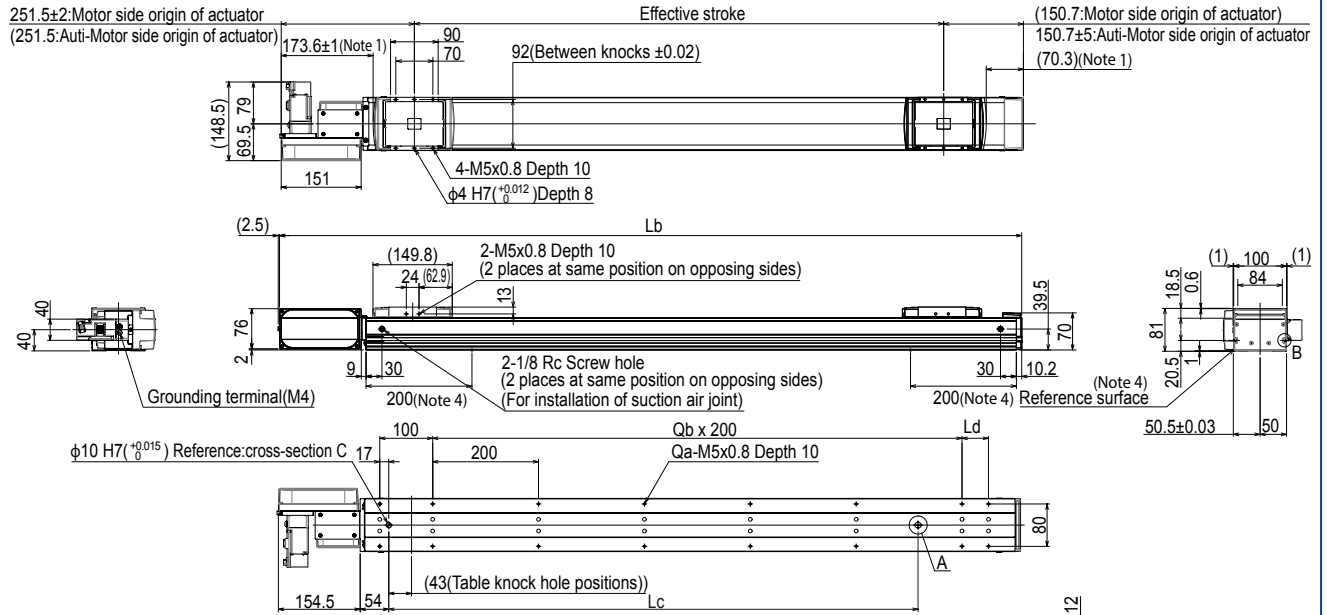

Note 1. Stop positions are determined by the mechanical stoppers at both ends.

Note 2. The robot cable is extracted from the front.

Note 3. The robot cable is extracted from the rear.

Note 4. When the effective stroke is 2050 mm or more, the reference plane is within 200 mm of the frame end face.

Note. The return-to-origin direction can be changed by changing the parameter. (The standard is that the origin is located on the motor side. For details about how to change the return-to-origin direction, see the instruction manual for EP-01.)

Note. In the installation tap hole, the length under head <<thickness of stand +10mm or less>> is recommended for the hex socket head bolts <M5x0.8> used to install the main unit.

Note. The minimum bending radius for robot cables should be R30 or more for fixed cables / R50 or more for movable cables.

Effective stroke	150	200	250	300	350	400	450	500	550	600	650	700	750	800	850	900	950	1000	1050	1100	1150	1200	1250	1300	1350	1400	1450	1500	1550
Lb	552.2	602.2	652.2	702.2	752.2	802.2	852.2	902.2	952.2	1002.2	1052.2	1102.2	1152.2	1202.2	1252.2	1302.2	1352.2	1402.2	1452.2	1502.2	1552.2	1602.2	1652.2	1702.2	1752.2	1802.2	1852.2	1902.2	1952.2
Lc	150	200	250	300	350	400	450	500	550	600	650	700	750	800	850	900	950	1000	1050	1100	1150	1200	1250	1300	1350	1400	1450	1500	1550
Ld	200	50	100	150	200	50	100	150	200	50	100	150	200	50	100	150	200	50	100	150	200	50	100	150	200	50	100	150	200
Qa	6	8	8	8	8	10	10	10	10	12	12	12	12	14	14	14	14	16	16	16	18	18	18	18	20	20	20	20	20
Qb	0	1	1	1	1	2	2	2	2	3	3	3	3	4	4	4	4	5	5	5	5	6	6	6	6	7	7	7	7
Weight (kg)	6.3	6.7	7.1	7.5	7.9	8.3	8.7	9.1	9.4	9.8	10.2	10.6	11	11.4	11.8	12.2	12.6	13	13.4	13.8	14.1	14.5	14.9	15.3	15.7	16.1	16.5	16.9	17.3

Stroke restriction	No stroke restrictions																															
	Horizontal-Vertical																To 2000st															
Stroke restriction	To 2000st																To 1500st															
	Effective stroke	1600	1650	1700	1750	1800	1850	1900	1950	2000	2050	2100	2150	2200	2250	2300	2350	2400	2450	2500	2550	2600	2650	2700	2750	2800	2850	2900	2950	3000		
Lb	2002.2	2052.2	2102.2	2152.2	2202.2	2252.2	2302.2	2352.2	2402.2	2452.2	2502.2	2552.2	2602.2	2652.2	2702.2	2752.2	2802.2	2852.2	2902.2	2952.2	3002.2	3052.2	3102.2	3152.2	3202.2	3252.2	3302.2	3352.2	3402.2			
Lc	1600	1650	1700	1750	1800	1850	1900	1950	2000	2050	2100	2150	2200	2250	2300	2350	2400	2450	2500	2550	2600	2650	2700	2750	2800	2850	2900	2950	3000			
Ld	50	100	150	200	50	100	150	200	50	100	150	200	50	100	150	200	50	100	150	200	50	100	150	200	50	100	150	200	50			
Qa	22	22	22	22	24	24	24	24	24	26	26	26	26	28	28	28	30	30	30	30	32	32	32	32	34	34	34	34	36			
Qb	8	8	8	8	9	9	9	9	9	10	10	10	10	11	11	11	11	12	12	12	12	13	13	13	13	14	14	14	15			
Weight (kg)	17.7	18.1	18.5	18.8	19.2	19.6	20	20.4	20.8	21.2	21.6	22	22.4	22.8	23.2	23.5	23.9	24.3	24.7	25.1	25.5	25.9	26.3	26.7	27.1	27.5	27.9	28.3	28.6			