

ABFS10/ABFS10H

Basic model **Single-axis robots**
 Low-profile type

Ordering method

本体	Lead	Shape	Motor specification	Stroke	Cable length	Cable entry location	Robot positioner	Driver: Power capacity	Regenerative unit	I/O	Battery
ABFS10	24: 24 mm	S: Straight	S: Standard/With no brake	50 to 1250 (50mm pitch)	R3: 3 m	R: From rear of motor	EP-01	A10: 200W or less A30: 400W/750W	No entry: None R: With EP-RU	EP: EtherNet/IP™ PT: PROFINET ES: EtherCAT NS: NPN CC: CC-Link	B: With battery N: None
ABFS10H	12: 12 mm 6: 6 mm	R: Right attachment L: Left attachment	BK: Standard/With brake BL: Battery-less absolute/With no brake BKL: Battery-less absolute/With brake		R5: 5 m R10: 10 m	F: From front of motor					

Note 1. The robot cable is flexible and resists bending.

Note 2. [For ABFS10]

When the actuator is used vertically, ①lead 24 is selected, and the stroke is 350 mm or more ②lead 12 is selected, and the stroke is 200mm or more ③lead 6 is selected, and the stroke is 150mm or more, the regenerative unit is needed. When the actuator is used horizontally, ①lead 24 is selected, and the stroke is 250 to 800 mm, ②lead 12 is selected, and the stroke is 450 to 700 mm, the regenerative unit is needed. [For ABFS10H]

When the actuator is used vertically, ①lead 24 is selected, and the stroke is 150 mm or more ②lead 12 is selected, and the stroke is 150mm or more ③lead 6 is selected, and the stroke is 250mm or more, the regenerative unit is needed.

When the actuator is used horizontally, ①lead 24 is selected, and the stroke is 450 to 600 mm, ②lead 12 is selected, and the stroke is 400 mm or more ③lead 6 is selected, and the stroke is 200mm or more, the regenerative unit is needed.

Note 3. When the motor specification is the standard (S, BK), whether to use the battery needs to be selected.

Note. The return-to-origin direction can be changed by changing the parameter. (The standard is that the origin is located on the motor side. For details about how to change the return-to-origin direction, see the instruction manual for EP-01.)

ABFS10 (200W)

Specifications

AC servo motor output	200 W		
Repeatability ^{Note 1}	±0.005 mm		
Deceleration mechanism	Rolled ball screw φ 14 (C7 class)		
Stroke	50 mm to 1250 mm (50 mm pitch)		
Maximum speed ^{Note 2}	1440 mm/sec	720 mm/sec	360 mm/sec
	24 mm	12 mm	6 mm
	Ball screw lead		
Maximum payload	Horizontal	40 kg	80 kg
	Vertical	8 kg	18 kg
Rated Thrust	142 N	284 N	569 N
	Dynamic loading moment (MY,MP,MR)		
	132.9 / 132.9 / 237.4		
Maximum dimensions of cross section of main unit			
W 100.3 mm × H 60 mm			
Overall length	Straight	ST + 372.5 mm	
	Bending	ST + 278.5 mm	
Degree of cleanliness ^{Note 3}			
Equivalent to ISO Class 4 (ISO 14644-1)			
Intake air ^{Note 4}	130 Nℓ/min~		
Using ambient temperature and humidity	0 to 40 °C, 35 to 80 %RH (no condensation)		

Note 1. Positioning repeatability in one direction, ±0.01 for the Bending configuration.
 Note 2. When a moving distance is short and depending on an operation condition, it may not reach the maximum speed. If the effective stroke exceeds 650 mm, the ball screw may resonate. (Critical speed)
 Note 3. When using in a clean environment, attach a suction air joint. The degree of cleanliness is the cleanliness level achieved when using at 1000 mm/sec or less.
 Note 4. The required suction amount will vary according to the operating conditions and operating environment.

Allowable overhang^{Note}

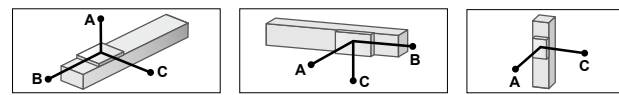

ABFS10-24	Horizontal installation (Unit: mm)			Wall installation (Unit: mm)			Vertical installation (Unit: mm)			
	A	B	C	A	B	C	A	B	C	
15kg	684	308	309	15kg	309	308	684	4kg	1083	1083
25kg	759	210	251	25kg	251	210	759	8kg	617	617
40kg	1496	156	235	40kg	235	156	1496			

ABFS10-12	Horizontal installation (Unit: mm)			Wall installation (Unit: mm)			Vertical installation (Unit: mm)			
	A	B	C	A	B	C	A	B	C	
30kg	1000	218	312	30kg	312	218	1000	10kg	726	726
50kg	730	118	174	50kg	174	118	730	18kg	406	406
80kg	481	62	92	80kg	92	62	481			

ABFS10-6	Horizontal installation (Unit: mm)			Wall installation (Unit: mm)			Vertical installation (Unit: mm)			
	A	B	C	A	B	C	A	B	C	
30kg	3539	256	434	30kg	434	256	3539	15kg	573	573
60kg	1965	112	190	60kg	190	112	1965	30kg	287	287
100kg	1326	54	93	100kg	93	54	1326			

Note. Distance from center of slider top to center of gravity of object being carried at a guide service life of 10,000 km.
 Note. Service life is calculated for 500 mm stroke models.

Static loading moment

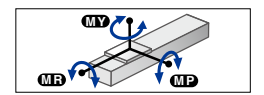

			(Unit: N·m)		
MY	MP	MR	MY	MP	MR
349	349	625			

Controller

Controller	Operation method
EP-01	I/O point trace/ Remote command

ABFS10H (400W)

Specifications

AC servo motor output	400 W		
Repeatability ^{Note 1}	±0.005 mm		
Deceleration mechanism	Rolled ball screw φ 14 (C7 class)		
Stroke	50 mm to 1250 mm (50 mm pitch)		
Maximum speed ^{Note 2}	1440 mm/sec	720 mm/sec	360 mm/sec
	24 mm	12 mm	6 mm
	Ball screw lead		
Maximum payload	Horizontal	50 kg	95 kg
	Vertical	15 kg	28 kg
Rated Thrust	289 N	578 N	1156 N
	Dynamic loading moment (MY,MP,MR)		
	132.9 / 132.9 / 237.4		
Maximum dimensions of cross section of main unit			
W 100.3 mm × H 60 mm			
Overall length	Straight	ST + 388.5 mm	
	Bending	ST + 278.5 mm	
Degree of cleanliness ^{Note 3}			
Equivalent to ISO Class 4 (ISO 14644-1)			
Intake air ^{Note 4}	130 Nℓ/min~		
Using ambient temperature and humidity	0 to 40 °C, 35 to 80 %RH (no condensation)		

Note 1. Positioning repeatability in one direction, ±0.01 for the Bending configuration.
 Note 2. When a moving distance is short and depending on an operation condition, it may not reach the maximum speed. If the effective stroke exceeds 650 mm, the ball screw may resonate. (Critical speed)
 Note 3. When using in a clean environment, attach a suction air joint. The degree of cleanliness is the cleanliness level achieved when using at 1000 mm/sec or less.
 Note 4. The required suction amount will vary according to the operating conditions and operating environment.

Allowable overhang^{Note}

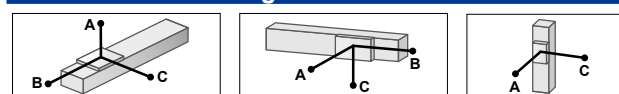

ABFS10H-24	Horizontal installation (Unit: mm)			Wall installation (Unit: mm)			Vertical installation (Unit: mm)			
	A	B	C	A	B	C	A	B	C	
15kg	550	308	290	15kg	290	308	550	8kg	713	713
30kg	579	166	197	30kg	189	179	460	15kg	321	321
50kg	1330	121	186	50kg	186	121	1330			

ABFS10H-12	Horizontal installation (Unit: mm)			Wall installation (Unit: mm)			Vertical installation (Unit: mm)			
	A	B	C	A	B	C	A	B	C	
30kg	833	218	305	30kg	305	218	833	14kg	516	516
60kg	533	93	136	60kg	136	93	533	28kg	261	261
95kg	354	47	70	95kg	70	47	354			

ABFS10H-6	Horizontal installation (Unit: mm)			Wall installation (Unit: mm)			Vertical installation (Unit: mm)			
	A	B	C	A	B	C	A	B	C	
40kg	2079	184	311	40kg	311	184	2079	18kg	476	476
80kg	1367	76	129	80kg	129	76	1367	37kg	232	232
115kg	1009	43	74	115kg	74	43	1009			

Note. Distance from center of slider top to center of gravity of object being carried at a guide service life of 10,000 km.
 Note. Service life is calculated for 500 mm stroke models.



▶ The cycle time simulation and service life calculation can be performed easily from our member site.

ABFS10 Straight type (S)

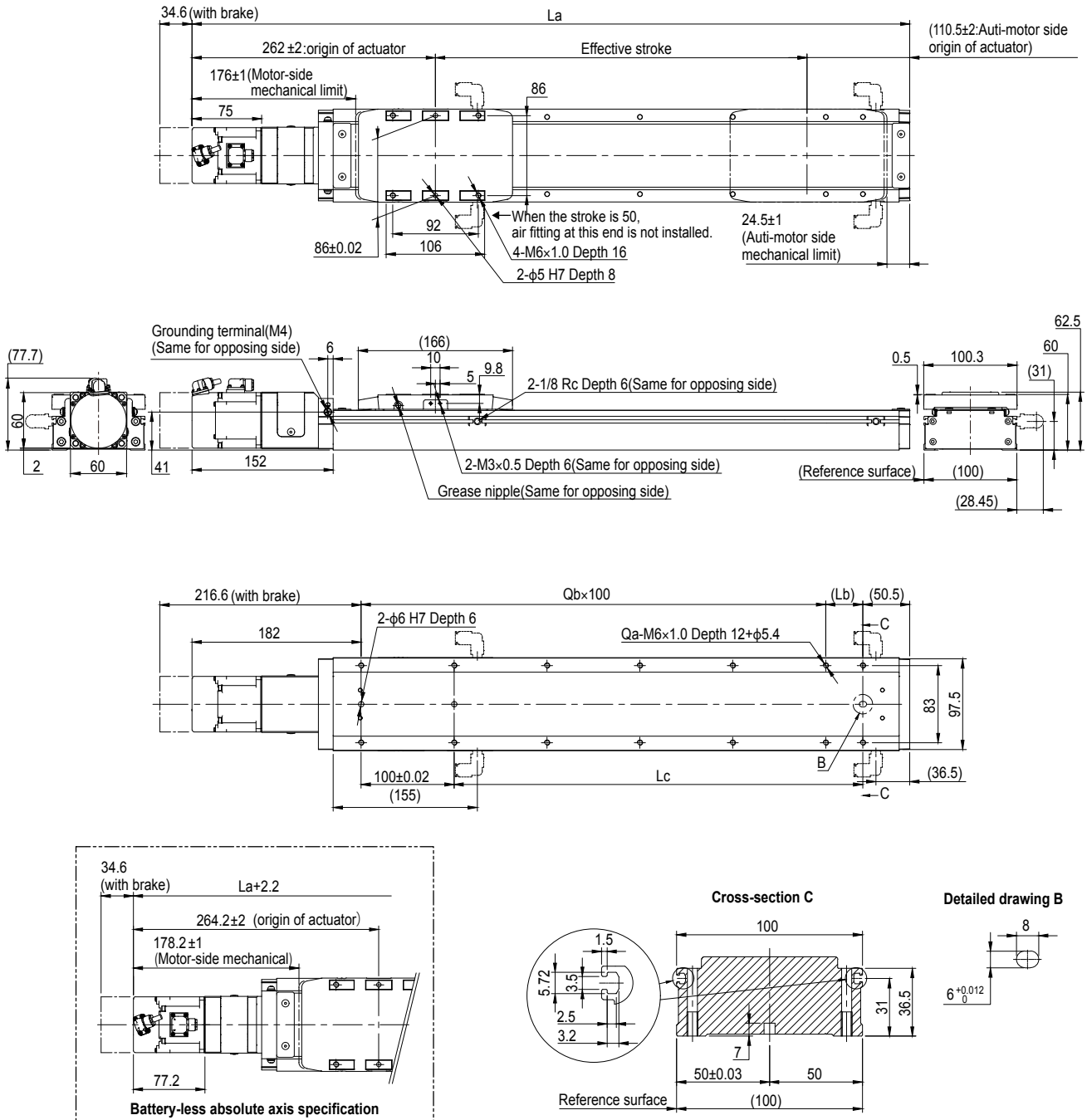

Note 1. Weight without brake. The weight with the brake is 0.4 kg heavier than the value in the weight column.
 Note. The return-to-origin direction can be changed by changing the parameter. (The standard is that the origin is located on the motor side. For details about how to change the return-to-origin direction, see the instruction manual for EP-01.)
 Note. For the installation through hole, the length under head <<45mm or more >> is recommended for the hex socket head bolts <M5×0.8>. In the installation tap hole, the length under head <<thickness of stand +12mm or less>> is recommended for the hex socket head bolts <M6×1.0> used to install the main unit.
 Note. Grease gun nozzle (recommended) Part number: KFU-M3861-00
 Note. The minimum bending radius for robot cables should be R30 or more for fixed cables / R50 or more for movable cables. The cable exit direction varies depending on the specifications.

Effective stroke	50	100	150	200	250	300	350	400	450	500	550	600	650	700	750	800	850	900	950	1000	1050	1100	1150	1200	1250
La	422.5	472.5	522.5	572.5	622.5	672.5	722.5	772.5	822.5	872.5	922.5	972.5	1022.5	1072.5	1122.5	1172.5	1222.5	1272.5	1322.5	1372.5	1422.5	1472.5	1522.5	1572.5	1622.5
Lb	90	40	90	40	90	40	90	40	90	40	90	40	90	40	90	40	90	40	90	40	90	40	90	40	90
Lc	90	140	190	240	290	340	390	440	490	540	590	640	690	740	790	840	890	940	990	1040	1090	1140	1190	1240	1290
Qa	6	8	8	10	10	12	12	14	14	16	16	18	18	20	20	22	22	24	24	26	26	28	28	30	30
Qb	1	2	2	3	3	4	4	5	5	6	6	7	7	8	8	9	9	10	10	11	11	12	12	13	13
Weight (kg) ^{Note 1}	4.19	4.50	4.82	5.14	5.46	5.78	6.09	6.41	6.73	7.05	7.37	7.68	8.01	8.33	8.65	8.97	9.29	9.60	9.92	10.24	10.56	10.88	11.19	11.51	11.83
Maximum speed (mm/sec)	Lead 24	1440											1224	1080	936	864	792	720	648	576	512	432	432	360	360
	Speed setting	-											85%	75%	65%	60%	55%	50%	45%	40%	36%	30%	30%	25%	25%
	Lead 12	720											612	540	468	432	396	360	324	288	256	216	216	180	180
	Speed setting	-											85%	75%	65%	60%	55%	50%	45%	40%	36%	30%	30%	25%	25%
	Lead 6	360											306	270	234	216	198	180	162	144	126	108	108	90	90
Speed setting	-											85%	75%	65%	60%	55%	50%	45%	40%	35%	30%	30%	25%	25%	

ABFS10 Bending type (R/L)

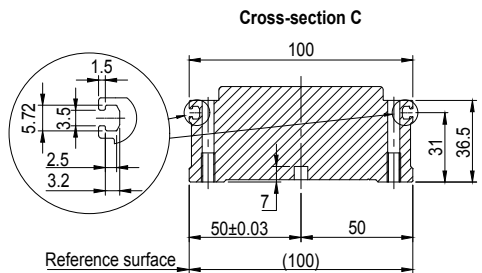
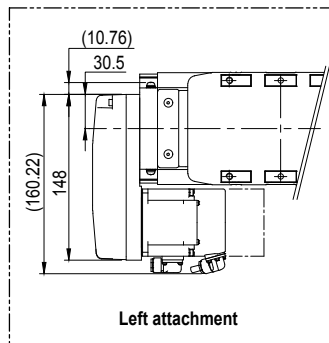
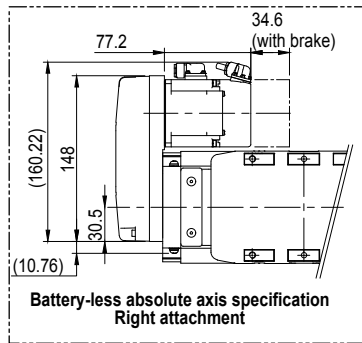
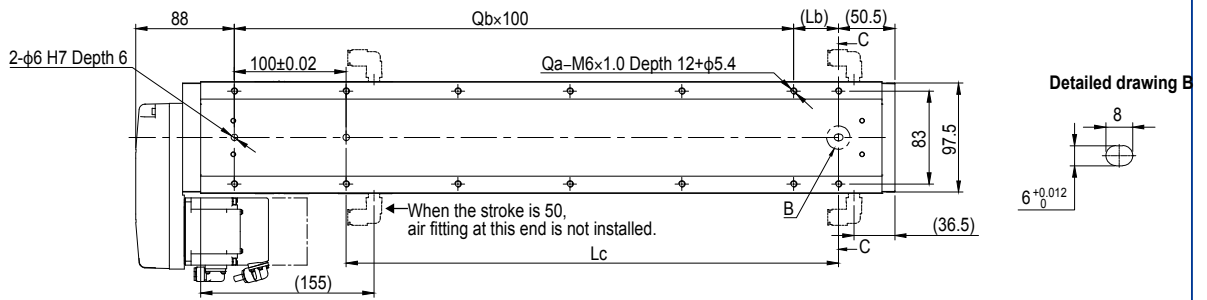
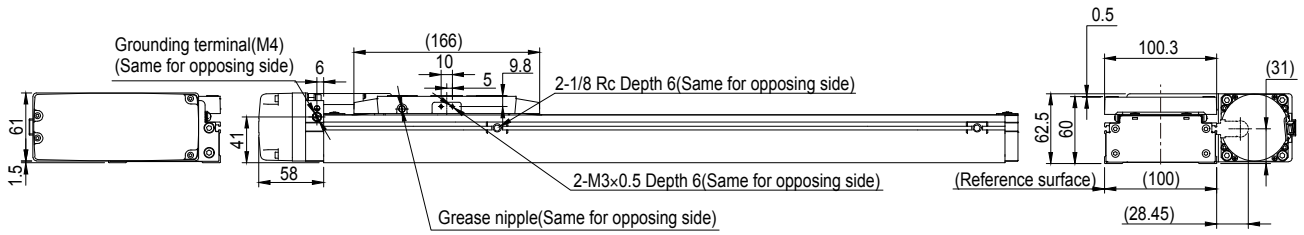
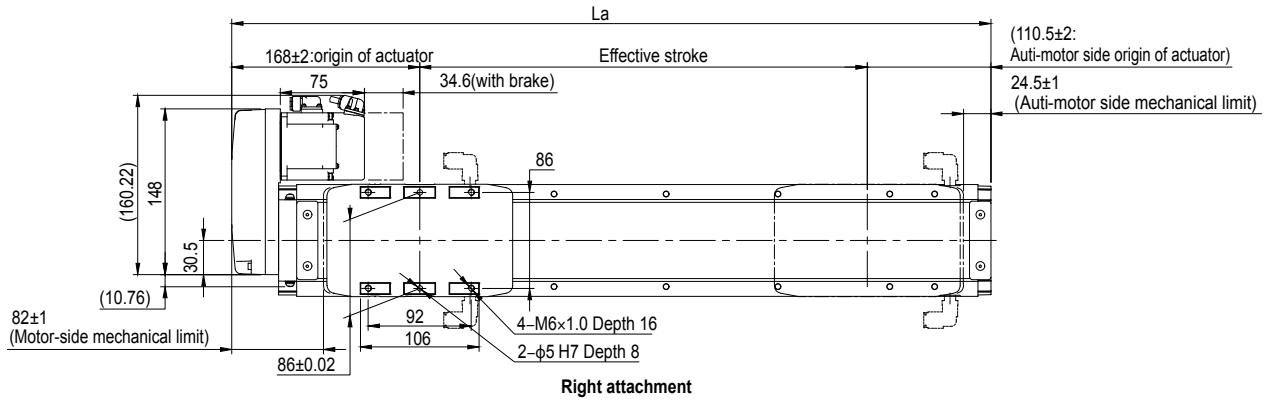

Note 1. Weight without brake. The weight with the brake is 0.4 kg heavier than the value in the weight column.

Note. The return-to-origin direction can be changed by changing the parameter. (The standard is that the origin is located on the motor side. For details about how to change the return-to-origin direction, see the instruction manual for EP-01.)

Note. For the installation through hole, the length under head <<45mm or more >> is recommended for the hex socket head bolts <M5×0.8>. In the installation tap hole, the length under head <<thickness of stand +12mm or less>> is recommended for the hex socket head bolts <M6×1.0> used to install the main unit.

Note. Grease gun nozzle (recommended) Part number: KFU-M3861-00

Note. The minimum bending radius for robot cables should be R30 or more for fixed cables / R50 or more for movable cables. The cable exit direction varies depending on the specifications.

Effective stroke	50	100	150	200	250	300	350	400	450	500	550	600	650	700	750	800	850	900	950	1000	1050	1100	1150	1200	1250
La	328.5	378.5	428.5	478.5	528.5	578.5	628.5	678.5	728.5	778.5	828.5	878.5	928.5	978.5	1028.5	1078.5	1128.5	1178.5	1228.5	1278.5	1328.5	1378.5	1428.5	1478.5	1528.5
Lb	90	40	90	40	90	40	90	40	90	40	90	40	90	40	90	40	90	40	90	40	90	40	90	40	90
Lc	90	140	190	240	290	340	390	440	490	540	590	640	690	740	790	840	890	940	990	1040	1090	1140	1190	1240	1290
Qa	6	8	8	10	10	12	12	14	14	16	16	18	18	20	20	22	22	24	24	26	26	28	28	30	30
Qb	1	2	2	3	3	4	4	5	5	6	6	7	7	8	8	9	9	10	10	11	11	12	12	13	13
Weight (kg) Note 1	4.16	4.50	4.84	5.18	5.52	5.86	6.20	6.54	6.88	7.22	7.56	7.90	8.24	8.58	8.92	9.26	9.60	9.94	10.28	10.62	10.96	11.30	11.64	11.98	12.32
Maximum speed (mm/sec)	Lead 24												1224	1080	936	864	792	720	648	576	512	432	432	360	360
	Speed setting												85%	75%	65%	60%	55%	50%	45%	40%	36%	30%	30%	25%	25%
	Lead 12												612	540	468	432	396	360	324	288	256	216	216	180	180
	Speed setting												85%	75%	65%	60%	55%	50%	45%	40%	36%	30%	30%	25%	25%
Maximum speed (mm/sec)	Lead 6												306	270	234	216	198	180	162	144	126	108	108	90	90
	Speed setting												85%	75%	65%	60%	55%	50%	45%	40%	35%	30%	30%	25%	25%