

ABFS08/ABFS08H

Basic model Single-axis robots

Low-profile type

Ordering method

							EP-01				
本体	Lead	Shape	Motor specification	Stroke	Cable length <small>Note 1</small>	Cable entry location	Robot positioner	Driver: Power capacity	Regenerative unit <small>Note 2</small>	I/O	Battery <small>Note 3</small>
ABFS08	24: 24 mm	S: Straight	S: Standard/With no brake BK: Standard/With brake	50 to 1250 (50mm pitch)	R3: 3 m R5: 5 m R10: 10 m	R: From rear of motor F: From front of motor	EP-01	A10: 200W or less A30: 400W/750W	No entry: None R: With EP-RU	EP: EtherNet/IP™ PT: PROFINET ES: EtherCAT NS: NPN CC: CC-Link	B: With battery N: None
ABFS08H	12: 12 mm 6: 6 mm	R: Right attachment L: Left attachment	BL: Battery-less absolute/ With no brake BKL: Battery-less absolute/ With brake								

Note 1. The robot cable is flexible and resists bending.

Note 2. [For ABFS08]

When the actuator is used vertically, ①lead 24 is selected, and the stroke is 350 mm or more ②lead 12 is selected, and the stroke is 150mm or more ③lead 6 is selected, and the stroke is 150mm or more, the regenerative unit is needed.
When the actuator is used horizontally, ①lead 24 is selected, and the stroke is 300 to 850 mm, ②lead 12 is selected, and the stroke is 450 to 600 mm, the regenerative unit is needed.
[For ABFS08H]

When the actuator is used vertically, ①lead 24 is selected, and the stroke is 150 mm or more ②lead 12 is selected, and the stroke is 150mm or more ③lead 6 is selected, and the stroke is 200mm or more, the regenerative unit is needed.

When the actuator is used horizontally, ①lead 24 is selected, and the stroke is 400 to 650 mm, ②lead 12 is selected, and the stroke is 400 mm or more ③lead 6 is selected, and the stroke is 200mm or more, the regenerative unit is needed.

Note 3. When the motor specification is the standard (S, BK), whether to use the battery needs to be selected.

Note. The return-to-origin direction can be changed by changing the parameter. (The standard is that the origin is located on the motor side. For details about how to change the return-to-origin direction, see the instruction manual for EP-01.)

ABFS08 (200W)

Specifications

AC servo motor output	200 W
Repeatability <small>Note 1</small>	±0.005 mm
Deceleration mechanism	Rolled ball screw φ 14 (C7 class)
Stroke	50 mm to 1250 mm (50 mm pitch)
Maximum speed <small>Note 2</small>	1440 mm/sec 720 mm/sec 360 mm/sec
Ball screw lead	24 mm 12 mm 6 mm
Maximum payload	Horizontal 40 kg 80 kg 100 kg Vertical 8 kg 18 kg 30 kg
Rated Thrust	142 N 284 N 569 N
Dinamic loading moment (MY,MP,MR)	99.4 / 99.4 / 158.3
Maximum dimensions of cross section of main unit	W 83 mm × H 56 mm
Overall length	Straight ST + 362.5 mm Bending ST + 268.5 mm
Degree of cleanliness <small>Note 3</small>	Equivalent to ISO Class 4 (ISO 14644-1)
Intake air <small>Note 4</small>	130 Nl/min~
Using ambient temperature and humidity	0 to 40 °C, 35 to 80 %RH (no condensation)

Note 1. Positioning repeatability in one direction, ±0.01 for the Bending configuration.

Note 2. When a moving distance is short and depending on an operation condition, it may not reach the maximum speed. If the effective stroke exceeds 650 mm, the ball screw may resonate. (Critical speed)

Note 3. When using in a clean environment, attach a suction air joint. The degree of cleanliness is the cleanliness level achieved when using at 1000 mm/sec or less.

Note 4. The required suction amount will vary according to the operating conditions and operating environment.

Allowable overhang

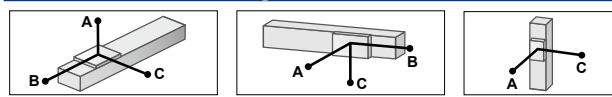

ABFS08-24	Horizontal installation (Unit: mm)			Wall installation (Unit: mm)			Vertical installation (Unit: mm)			
	A	B	C	A	B	C	A	B	C	
15kg	505	228	213	15kg	213	228	505	4kg	810	810
25kg	557	154	169	25kg	169	154	557	8kg	461	461
40kg	1089	113	154	45kg	154	113	1089			

ABFS08-12	Horizontal installation (Unit: mm)			Wall installation (Unit: mm)			Vertical installation (Unit: mm)			
	A	B	C	A	B	C	A	B	C	
30kg	739	160	208	30kg	208	160	739	10kg	543	543
50kg	531	85	113	50kg	113	85	531	18kg	304	304
80kg	339	43	58	80kg	58	43	339			

ABFS08-6	Horizontal installation (Unit: mm)			Wall installation (Unit: mm)			Vertical installation (Unit: mm)			
	A	B	C	A	B	C	A	B	C	
30kg	2623	188	284	30kg	284	188	2623	15kg	428	428
60kg	1436	81	122	60kg	122	81	1436	30kg	214	214
100kg	936	38	57	100kg	57	38	936			

Note. Distance from center of slider top to center of gravity of object being carried at a guide service life of 10,000 km.

Note. Service life is calculated for 500 mm stroke models.

Static loading moment

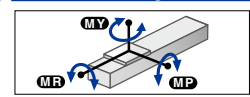

	MY	MP	MR
(Unit: N·m)	249	249	393

Controller

Controller	Operation method
EP-01	I/O point trace/ Remote command

ABFS08H (400W)

Specifications

AC servo motor output	400 W
Repeatability <small>Note 1</small>	±0.005 mm
Deceleration mechanism	Rolled ball screw φ 14 (C7 class)
Stroke	50 mm to 1250 mm (50 mm pitch)
Maximum speed <small>Note 2</small>	1440 mm/sec 720 mm/sec 360 mm/sec
Ball screw lead	24 mm 12 mm 6 mm
Maximum payload	Horizontal 50 kg 95 kg 115 kg Vertical 15 kg 28 kg 37 kg
Rated Thrust	289 N 578 N 1156 N
Dinamic loading moment (MY,MP,MR)	99.4 / 99.4 / 158.3
Maximum dimensions of cross section of main unit	W 83 mm × H 56 mm
Overall length	Straight ST + 378.5 mm Bending ST + 268.5 mm
Degree of cleanliness <small>Note 3</small>	Equivalent to ISO Class 4 (ISO 14644-1)
Intake air <small>Note 4</small>	130 Nl/min~
Using ambient temperature and humidity	0 to 40 °C, 35 to 80 %RH (no condensation)

Note 1. Positioning repeatability in one direction, ±0.01 for the Bending configuration.

Note 2. When a moving distance is short and depending on an operation condition, it may not reach the maximum speed. If the effective stroke exceeds 650 mm, the ball screw may resonate. (Critical speed)

Note 3. When using in a clean environment, attach a suction air joint. The degree of cleanliness is the cleanliness level achieved when using at 1000 mm/sec or less.

Note 4. The required suction amount will vary according to the operating conditions and operating environment.

Allowable overhang

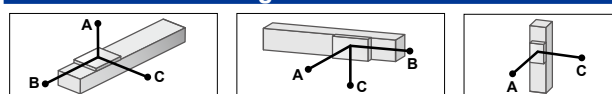

ABFS08H-24	Horizontal installation (Unit: mm)			Wall installation (Unit: mm)			Vertical installation (Unit: mm)			
	A	B	C	A	B	C	A	B	C	
15kg	407	228	201	15kg	201	228	407	8kg	400	400
30kg	422	121	132	30kg	128	131	422	15kg	240	240
50kg	961	87	121	50kg	121	87	961			

ABFS08H-12	Horizontal installation (Unit: mm)			Wall installation (Unit: mm)			Vertical installation (Unit: mm)			
	A	B	C	A	B	C	A	B	C	
30kg	616	160	205	30kg	205	160	616	14kg	386	386
60kg	386	66	88	60kg	88	66	386	28kg	195	195
95kg	245	32	43	95kg	43	32	245			

ABFS08H-6	Horizontal installation (Unit: mm)			Wall installation (Unit: mm)			Vertical installation (Unit: mm)			
	A	B	C	A	B	C	A	B	C	
40kg	1538	134	202	40kg	202	134	1538	18kg	356	356
80kg	988	54	81	80kg	81	54	988	37kg	174	174
115kg	702	29	44	115kg	44	29	702			

Note. Distance from center of slider top to center of gravity of object being carried at a guide service life of 10,000 km.

Note. Service life is calculated for 500 mm stroke models.



▶ The cycle time simulation and service life calculation can be performed easily from our member site.

ABFS08H Straight type (S)

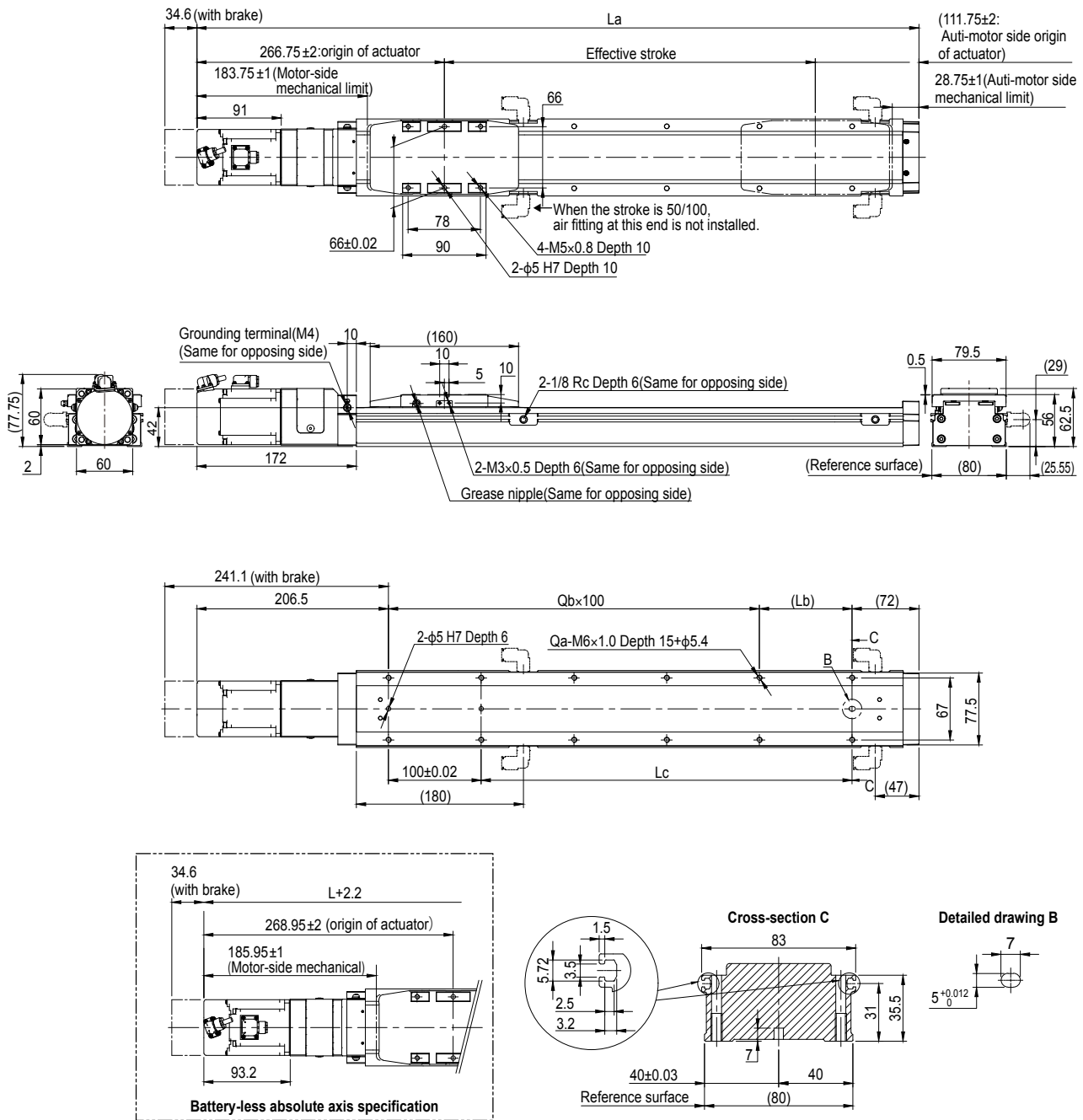

Note 1. Weight without brake. The weight with the brake is 0.4 kg heavier than the value in the weight column.

Note. The return-to-origin direction can be changed by changing the parameter. (The standard is that the origin is located on the motor side. For details about how to change the return-to-origin direction, see the instruction manual for EP-01.)

Note. For the installation through hole, the length under head <<45mm or more >> is recommended for the hex socket head bolts <M5×0.8>. In the installation tap hole, the length under head <<thickness of stand +15mm or less>> is recommended for the hex socket head bolts <M6×1.0> used to install the main unit.

Note. Grease gun nozzle (recommended) Part number: KFU-M3861-00

Note. The minimum bending radius for robot cables should be R30 or more for fixed cables / R50 or more for movable cables. The cable exit direction varies depending on the specifications.

Effective stroke	50	100	150	200	250	300	350	400	450	500	550	600	650	700	750	800	850	900	950	1000	1050	1100	1150	1200	1250	
La	428.5	478.5	528.5	578.5	628.5	678.5	728.5	778.5	828.5	878.5	928.5	978.5	1028.5	1078.5	1128.5	1178.5	1228.5	1278.5	1328.5	1378.5	1428.5	1478.5	1528.5	1578.5	1628.5	
Lb	50	100	50	100	50	100	50	100	50	100	50	100	50	100	50	100	50	100	50	100	50	100	50	100	50	
Lc	50	100	150	200	250	300	350	400	450	500	550	600	650	700	750	800	850	900	950	1000	1050	1100	1150	1200	1250	
Qa	6	6	8	8	10	10	12	12	14	14	16	16	18	18	20	20	22	22	24	24	26	26	28	28	30	
Qb	1	1	2	2	3	3	4	4	5	5	6	6	7	7	8	8	9	9	10	10	11	11	12	12	13	
Weight (kg) ^{Note 1}	4.35	4.62	4.89	5.16	5.43	5.70	5.97	6.24	6.51	6.78	7.05	7.32	7.59	7.86	8.12	8.39	8.66	8.93	9.20	9.47	9.74	10.01	10.28	10.55	10.82	
Maximum speed (mm/sec)	Lead 24											1224	1080	936	864	792	720	648	576	512	432	432	360	360		
	Speed setting											85%	75%	65%	60%	55%	50%	45%	40%	36%	30%	30%	25%	25%		
	Lead 12											612	540	468	432	396	360	324	288	256	216	216	180	180		
	Speed setting											85%	75%	65%	60%	55%	50%	45%	40%	36%	30%	30%	25%	25%		
	Lead 6											306	270	234	216	198	180	162	144	126	108	108	90	90		
	Speed setting											85%	75%	65%	60%	55%	50%	45%	40%	35%	30%	30%	25%	25%		

ABFS08H Bending type (R/L)

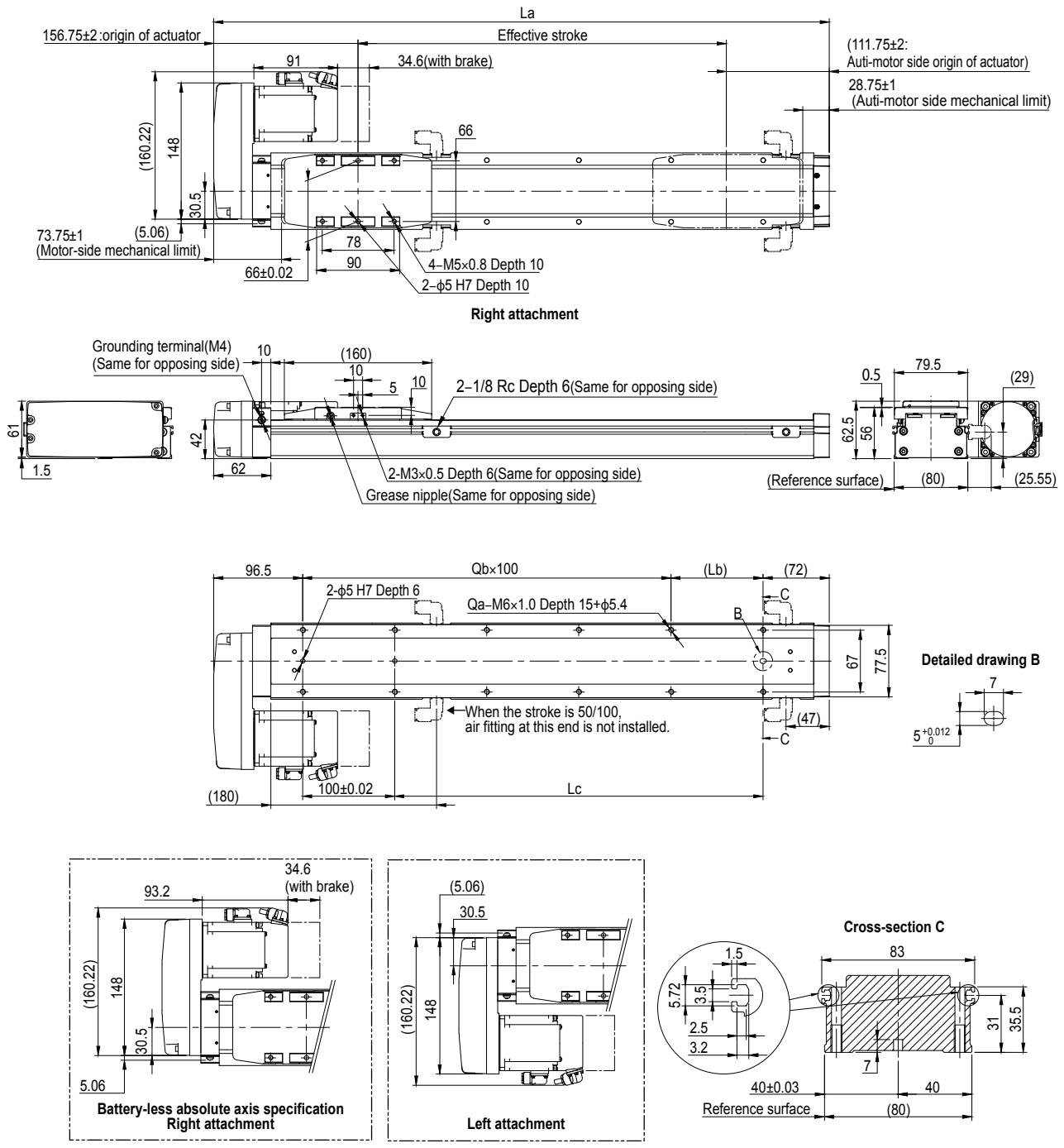

Note 1.Weight without brake. The weight with the brake is 0.4 kg heavier than the value in the weight column.
 Note. The return-to-origin direction can be changed by changing the parameter. (The standard is that the origin is located on the motor side. For details about how to change the return-to-origin direction, see the instruction manual for EP-01.)
 Note. For the installation through hole,the length under head <<45mm or more >> is recommended for the hex socket head bolts <M5×0.8>. In the installation tap hole, the length under head <<thickness of stand +15mm or less>> is recommended for the hex socket head bolts <M6×1.0> used to install the main unit.
 Note. Grease gun nozzle (recommended) Part number: KFU-M3861-00
 Note. The minimum bending radius for robot cables should be R30 or more for fixed cables / R50 or more for movable cables. The cable exit direction varies depending on the specifications.

Effective stroke	50	100	150	200	250	300	350	400	450	500	550	600	650	700	750	800	850	900	950	1000	1050	1100	1150	1200	1250
La	318.5	368.5	418.5	468.5	518.5	568.5	618.5	668.5	718.5	768.5	818.5	868.5	918.5	968.5	1018.5	1068.5	1118.5	1168.5	1218.5	1268.5	1318.5	1368.5	1418.5	1468.5	1518.5
Lb	50	100	50	100	50	100	50	100	50	100	50	100	50	100	50	100	50	100	50	100	50	100	50	100	50
Lc	50	100	150	200	250	300	350	400	450	500	550	600	650	700	750	800	850	900	950	1000	1050	1100	1150	1200	1250
Qa	6	6	8	8	10	10	12	12	14	14	16	16	18	18	20	20	22	22	24	24	26	26	28	28	30
Qb	1	1	2	2	3	3	4	4	5	5	6	6	7	7	8	8	9	9	10	10	11	11	12	12	13
Weight (kg) ^{Note 1}	4.16	4.45	4.73	5.02	5.31	5.60	5.88	6.17	6.46	6.75	7.03	7.32	7.61	7.90	8.18	8.47	8.76	9.05	9.33	9.62	9.91	10.20	10.48	10.77	11.06
Maximum speed (mm/sec)	Lead 24	1440											1224	1080	936	864	792	720	648	576	512	432	432	360	360
	Speed setting	-											85%	75%	65%	60%	55%	50%	45%	40%	36%	30%	30%	25%	25%
	Lead 12	720											612	540	468	432	396	360	324	288	256	216	216	180	180
	Speed setting	-											85%	75%	65%	60%	55%	50%	45%	40%	36%	30%	30%	25%	25%
Maximum speed (mm/sec)	Lead 6	360											306	270	234	216	198	180	162	144	126	108	108	90	90
	Speed setting	-											85%	75%	65%	60%	55%	50%	45%	40%	35%	30%	30%	25%	25%