

# ABAR08

Basic model

Single-axis robots

Rod type



## Ordering method

<b>ABAR08</b>							<b>EP-01</b>				
<b>Model</b>	<b>Lead</b>	<b>Shape</b>	<b>Motor specification</b>	<b>Stroke</b>	<b>Cable length</b> <small>Note 1</small>	<b>Cable entry location</b>	<b>Robot positioner</b>	<b>Driver: Power capacity</b>	<b>Regenerative unit</b> <small>Note 2</small>	<b>I/O</b> <small>Note 3</small>	<b>Battery</b> <small>Note 3</small>
	20: 20 mm 10: 10 mm 5: 5 mm	S: Straight R: Right bending L: Left bending	S: Standard/With no brake BK: Standard/With brake BL: Battery-less absolute/ With no brake BKBL: Battery-less absolute/ With brake	50 to 800 (50mm pitch)	R3: 3 m R5: 5 m R10: 10 m	R: From rear of motor F: From front of motor	EP-01	A10: 200W or less	No entry: None R: With EP-RU	EP: EtherNet/IP™ PT: PROFINET ES: EtherCAT NS: NPN CC: CC-Link	B: With battery N: None

Note 1. The robot cable is flexible and resists bending.

Note 2. When the actuator is used vertically, the regenerative unit is needed.

When the actuator is used horizontally and the stroke of lead 10 or 20 is 150 to 500 mm, the regenerative unit is needed.

Note 3. When the motor specification is the standard (S, BK), whether to use the battery needs to be selected.

## Specifications

<b>AC servo motor output</b>	200 W		
<b>Repeatability</b> <small>Note 1</small>	+/- 0.01 mm		
<b>Deceleration mechanism</b>	Shifting position ball screw $\phi$ 16 (C7 class)		
<b>Stroke</b>	50 mm to 800 mm (50mm pitch)		
<b>Maximum speed</b> <small>Note 2</small>	1200 mm/sec	600 mm/sec	300 mm/sec
<b>Ball screw lead</b>	20 mm	10 mm	5 mm
<b>Maximum payload</b>	<b>Horizontal</b>	30 kg	60 kg
	<b>Vertical</b>	8 kg	20 kg
<b>Max. pressing force</b>	201 N	402 N	804 N
<b>Rotating backlash</b>	+/- 0 °		
<b>Maximum dimensions of cross section of main unit</b>	W 82 mm x H 73.5 mm		
<b>Overall length</b>	<b>Straight</b>	ST + 401 mm	
	<b>Bending</b>	ST + 312.5 mm	
<b>Position detector</b>	Absolute encoder Battery-less absolute encoder		
<b>Resolution</b>	23 bits		
<b>Using ambient temperature and humidity</b>	0 to 40 °C, 35 to 80 %RH (non-condensing)		

Note 1. Positioning repeatability in one direction.

Note 2. When a moving distance is short and depending on an operation condition, it may not reach the maximum speed.

If the effective stroke exceeds 400 mm, the ball screw may resonate. (Critical speed)

At this time, make the adjustment to decrease the speed while referring to the maximum speed shown in the table.

Note. See P.138 for acceleration/deceleration.

## Controller

Controller	Operation method
EP-01	I/O point trace/Remote command

## Pushing force (reference value)

For the pushing force during pushing operation, see the graph below.

Note. The operable time (pushing judgement time) depends on the current limit value. Use the pushing force under the conditions that no overload error occurs.

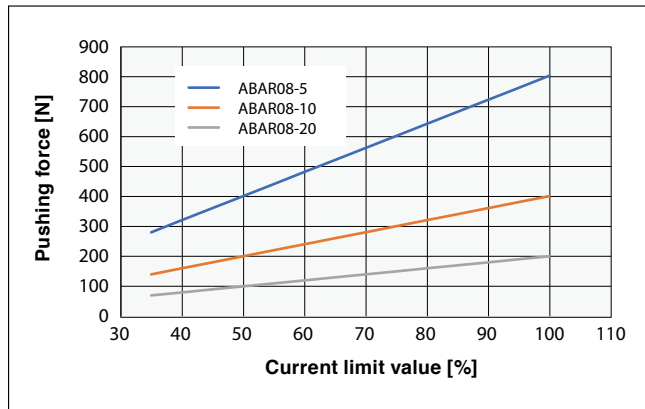

## Rod deflection amount (reference value)

For the deflection amount per stroke, see the graph below.

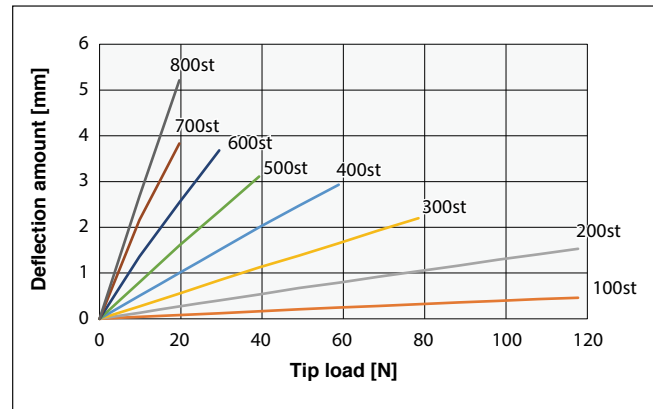

Access the website below.



▶ The cycle time simulation can be performed easily from our member site. For details, see P.12.

■ Allowable payload

For the allowable payload per offset amount, see the graph below.

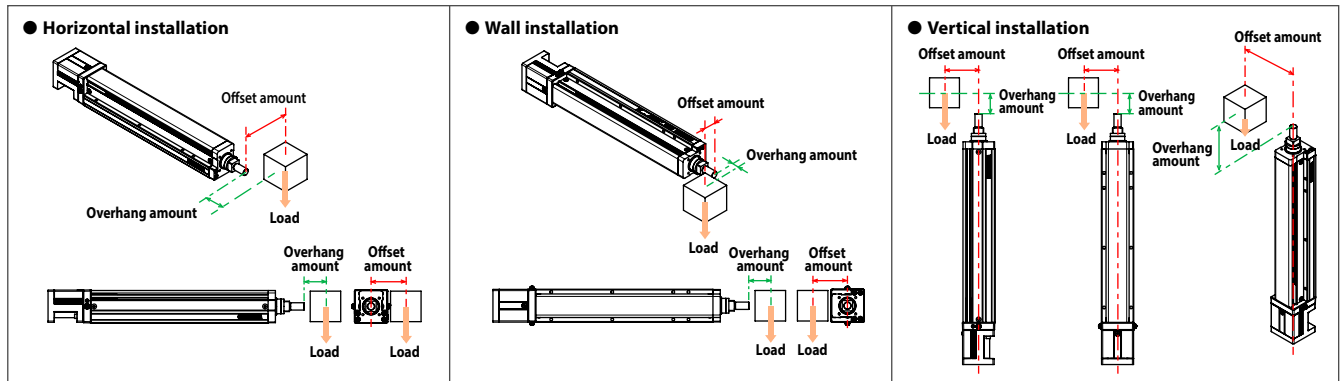

Note 1. When transferring an object with a weight exceeding the following, use an external support guide. Install the support guide flexibly so that no unnecessary load is applied to the rod.  
 Note 2. The values are when the service life of the guide is 5000 km.

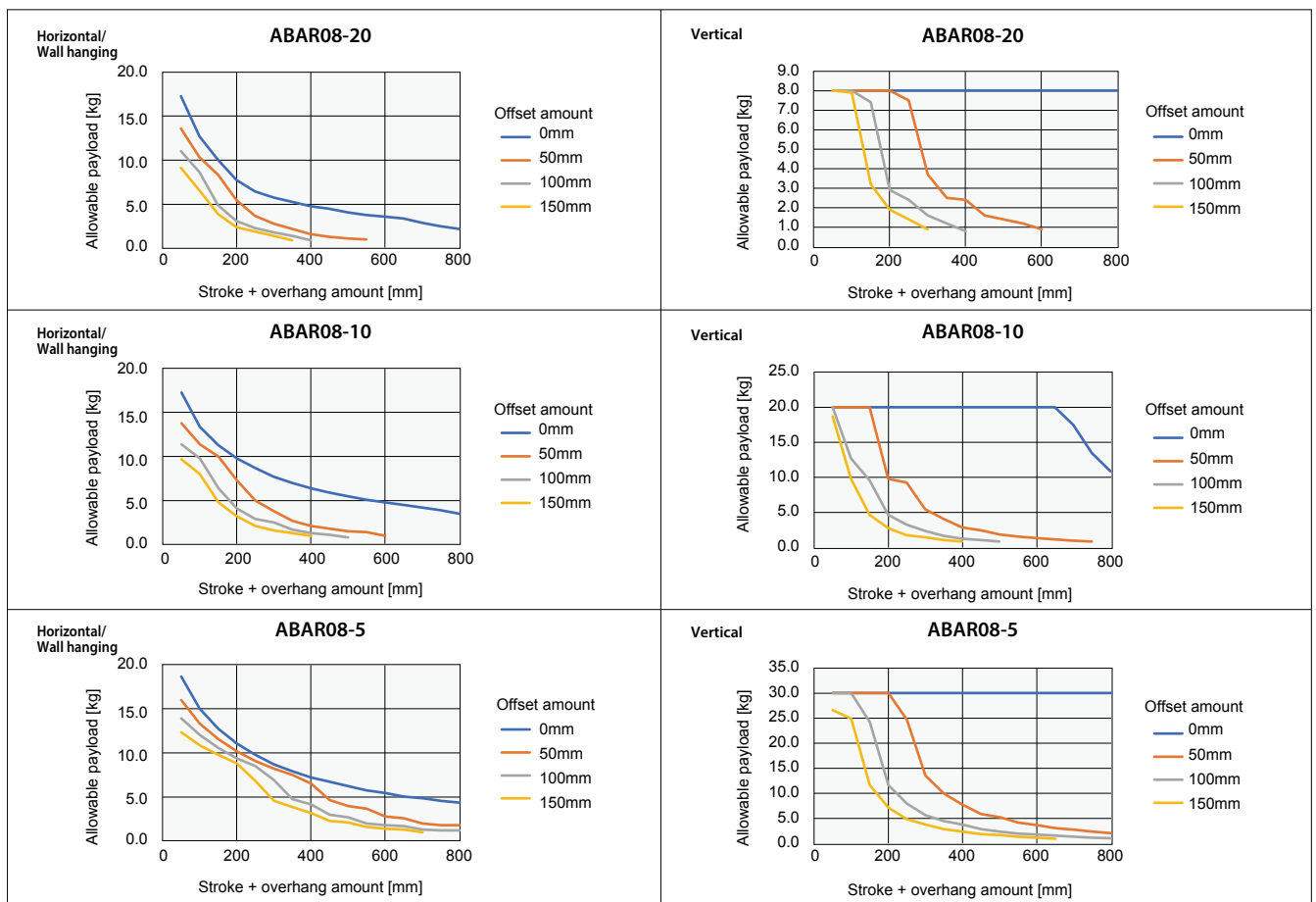

Features  
 Motorless  
 Basic model  
 LBAS  
 Motorless  
 Advanced model  
 LGXS  
 Motorless  
 Basic model  
 LBAR  
 With motor  
 Basic model  
 ABAS  
 With motor  
 Advanced model  
 AGXS  
 With motor  
 Basic model  
 ABAR  
 Acceleration/Deceleration  
 Inertia Moment  
 Option  
 Single axis robot positioner  
 EP-01

ABAR08 Straight type (S)

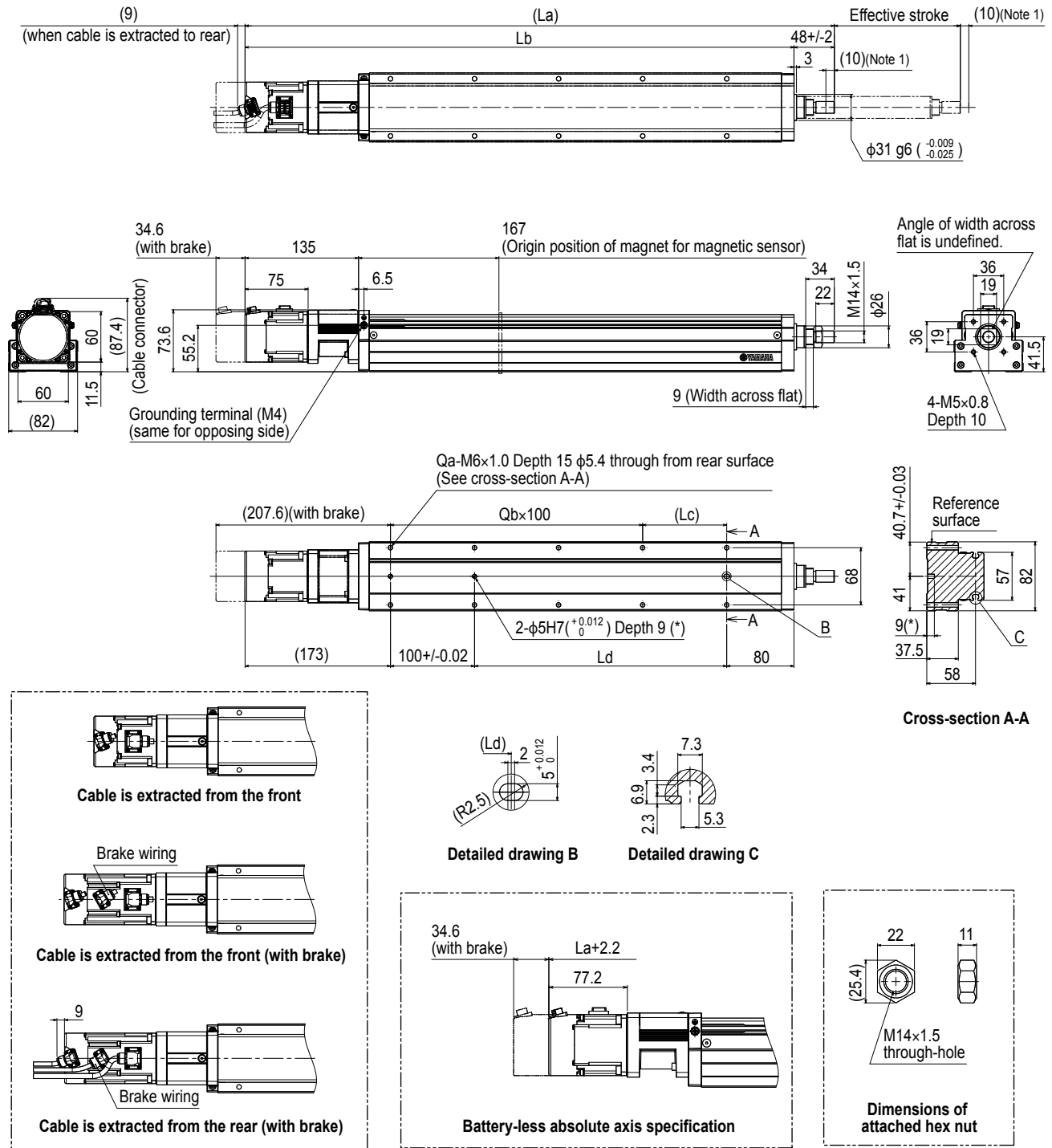

Note 1. Stop positions are determined by the mechanical stoppers at both ends.

Note 2. When changing the return-to-origin direction, the parameter needs to be changed. (The standard is that the origin is located on the motor side.)

Note 3. For the installation through hole, the length under head << 45 mm or more >> is recommended for the hex socket head bolts <M5 x 0.8>. In the installation tap hole, the length under head << thickness of stand +15 mm or less >> is recommended for the hex socket head bolts <M6 x 1.0> used to install the main unit.

Note 4. The weight with the brake is 0.4 kg heavier than the value in the weight column.

Note 5. The minimum bending radius of the robot cable is R30 on the fixed side or R50 on the movable side. The cable extraction direction may vary depending on the specifications.

Note 6. Grease gun nozzle (recommended) (see P.143 for detail)

Part number: KFU-M3861-00

Effective stroke	50	100	150	200	250	300	350	400	450	500	550	600	650	700	750	800	
La	451	501	551	601	651	701	751	801	851	901	951	1001	1051	1101	1151	1201	
Lb	403	453	503	553	603	653	703	753	803	853	903	953	1003	1053	1103	1153	
Lc	50	100	50	100	50	100	50	100	50	100	50	100	50	100	50	100	
Ld	50	100	150	200	250	300	350	400	450	500	550	600	650	700	750	800	
Qa	6	6	8	8	10	10	12	12	14	14	16	16	18	18	20	20	
Qb	1	1	2	2	3	3	4	4	5	5	6	6	7	7	8	8	
Weight (kg) Note 4	4.7	5.1	5.5	5.8	6.1	6.5	6.8	7.1	7.4	7.8	8.2	8.5	8.9	9.2	9.4	9.7	
Maximum speed (mm/sec)	Lead 20	1200								900	720	600	480	420	360	300	240
	Lead 10	600								450	360	300	240	210	180	150	120
	Lead 5	300								225	180	150	120	105	90	75	60
Speed setting	-								75%	60%	50%	40%	35%	30%	25%	20%	

ABAR08 Bending type (R/L)

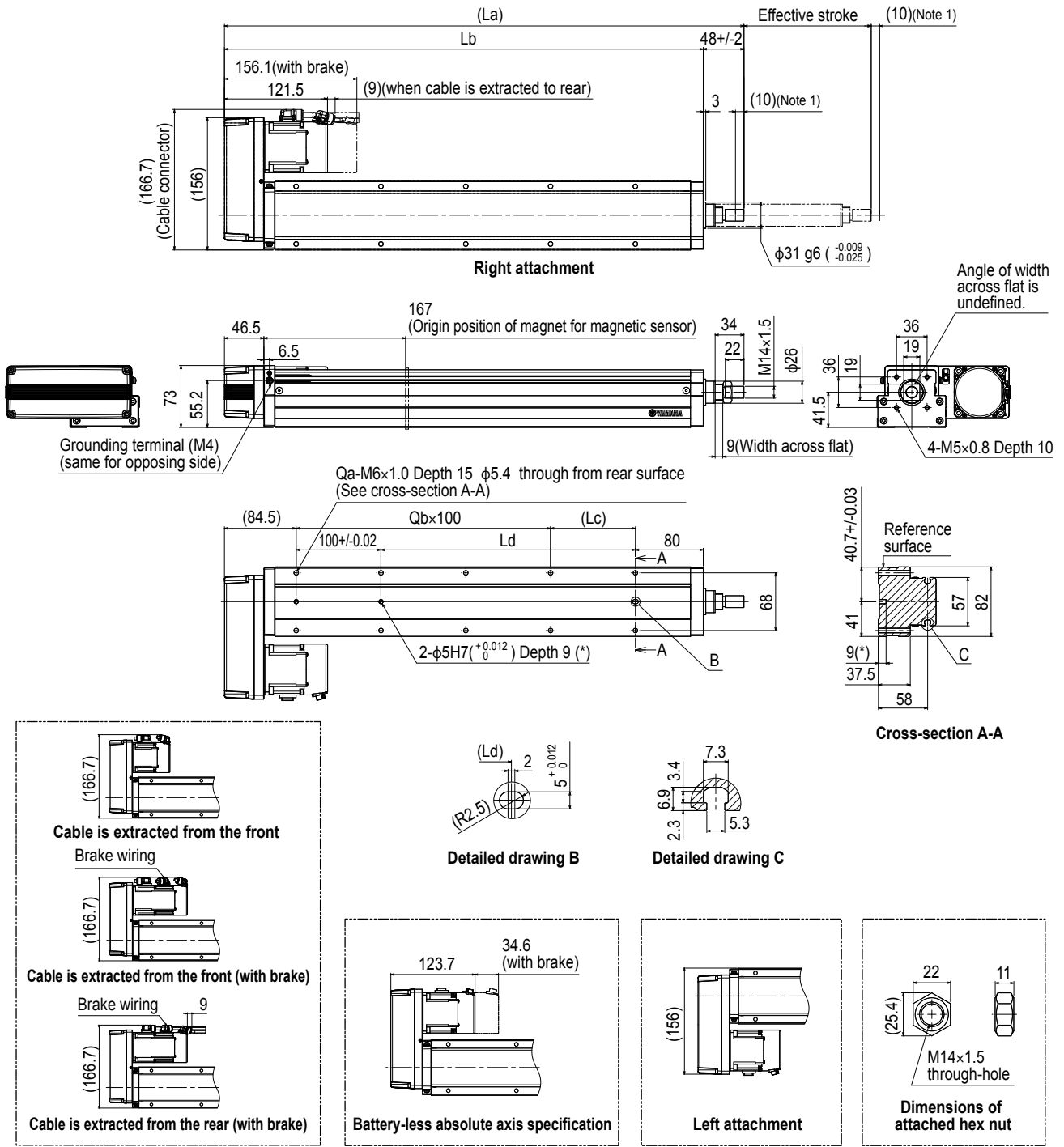

Note 1. Stop positions are determined by the mechanical stoppers at both ends.  
 Note 2. When changing the return-to-origin direction, the parameter needs to be changed. (The standard is that the origin is located on the motor side.)  
 Note 3. For the installation through hole, the length under head << 45 mm or more >> is recommended for the hex socket head bolts <M5 × 0.8>. In the installation tap hole, the length under head << thickness of stand + 15 mm or less >> is recommended for the hex socket head bolts <M6 × 1.0> used to install the main unit.  
 Note 4. The weight with the brake is 0.4 kg heavier than the value in the weight column.  
 Note 5. The minimum bending radius of the robot cable is R30 on the fixed side or R50 on the movable side. The cable extraction direction may vary depending on the specifications.  
 Note 6. Grease gun nozzle (recommended) (see P.143 for detail)  
 Part number: KFU-M3861-00

Effective stroke	50	100	150	200	250	300	350	400	450	500	550	600	650	700	750	800	
<b>La</b>	362.5	412.5	462.5	512.5	562.5	612.5	662.5	712.5	762.5	812.5	862.5	912.5	962.5	1012.5	1062.5	1112.5	
<b>Lb</b>	314.5	364.5	414.5	464.5	514.5	564.5	614.5	664.5	714.5	764.5	814.5	864.5	914.5	964.5	1014.5	1064.5	
<b>Lc</b>	50	100	50	100	50	100	50	100	50	100	50	100	50	100	50	100	
<b>Ld</b>	50	100	150	200	250	300	350	400	450	500	550	600	650	700	750	800	
<b>Qa</b>	6	6	8	8	10	10	12	12	14	14	16	16	18	18	20	20	
<b>Qb</b>	1	1	2	2	3	3	4	4	5	5	6	6	7	7	8	8	
<b>Weight (kg)</b> <small>Note 4</small>	5.1	5.5	5.9	6.2	6.5	6.9	7.2	7.5	7.8	8.2	8.6	8.9	9.3	9.6	9.8	10.1	
<b>Maximum speed (mm/sec)</b>	<b>Lead 20</b>	1200								900	720	600	480	420	360	300	240
	<b>Lead 10</b>	600								450	360	300	240	210	180	150	120
	<b>Lead 5</b>	300								225	180	150	120	105	90	75	60
	<b>Speed setting</b>	-								75%	60%	50%	40%	35%	30%	25%	20%