

# LGBS10

Advanced model

Motor-less Single Axis Actuator

Timing Belt Drive type

## Ordering method

### LGBS10

Model	Lead	Shape	Motor specification	Stroke
	50: 50 mm 30: 30 mm	R: Motor rightward, horizontal position L: Motor leftward, horizontal position RU: Motor rightward, upper position LU: Motor leftward, upper position RD: Motor rightward, lower position LD: Motor leftward, lower position	Y: Y specification (Only lead 30) (see below) T: T specification (see below) P: P specification (see below)	150 to 3000 (50 mm pitch)

### [Caution]

This system is provided as mechanical actuator unit and not including any adapters or electric components. Motor, driver and other components required for installation are the user's responsibility. Refer to user's manual for installation details. Refer to your motor manual for tuning or adjustment. Vibration or resonance from actuator will affect service life of actuator. The product performance may not be satisfied depending on the compatible motor. For special parts for motor installation, install and adjust on your side.

### LGBS10 (100W)

## Specifications

Applicable motor	100 W	
Repeatability <sup>Note 1</sup>	±0.04 mm	
Stroke	150 mm to 3000 mm (50 mm pitch)	
Maximum Speed <sup>Note 2</sup>	2250 mm/sec	
Belt	Equivalent to 30-mm Lead	
Maximum payload <sup>Note 3</sup> / Horizontal	12 kg	
Maximum dimensions of cross section of main unit	W 100 mm × H 81 mm	
Overall length	L/R Specifications	ST + 402.2 mm
	Other than the above	ST + 332.7 mm
Degree of Cleanliness <sup>Note 4</sup>	Equivalent to ISO Class 3 (ISO 14644-1)	
Intake air <sup>Note 5</sup>	60Nℓ/min to 70Nℓ/min	
Using ambient temperature and humidity	0 to 40 °C, 35 to 80 %RH (no condensation)	

- Note 1. Positioning repeatability in one direction.  
 Note 2. When a moving distance is short and depending on an operation condition, it may not reach the maximum speed.  
 Note 3. The rated thrust and maximum transferable weight are values assuming the attached motor outputs the rated torque.  
 Note 4. When using in a clean environment, attach a suction air joint. The degree of cleanliness is the cleanliness level achieved when using at 1000 mm/sec or less.  
 Note 5. The required suction amount will vary according to the operating conditions and operating environment.

## Static loading moment

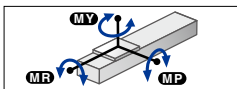

	MY	MP	MR
(Unit: N·m)	186	186	164

### LGBS10 (200W)

## Specifications

Applicable motor	200 W	
Repeatability <sup>Note 1</sup>	±0.04 mm	
Stroke	150 mm to 3000 mm (50 mm pitch)	
Maximum Speed <sup>Note 2</sup>	3750 mm/sec	
Belt	Equivalent to 50-mm Lead	
Maximum payload <sup>Note 3</sup> / Horizontal	18 kg	
Maximum dimensions of cross section of main unit	W 100 mm × H 81 mm	
Overall length	L/R Specifications	ST + 402.2 mm
	Other than the above	ST + 332.7 mm
Degree of Cleanliness <sup>Note 4</sup>	Equivalent to ISO Class 3 (ISO 14644-1)	
Intake air <sup>Note 5</sup>	60Nℓ/min to 70Nℓ/min	
Using ambient temperature and humidity	0 to 40 °C, 35 to 80 %RH (no condensation)	

- Note 1. Positioning repeatability in one direction.  
 Note 2. When a moving distance is short and depending on an operation condition, it may not reach the maximum speed.  
 Note 3. The rated thrust and maximum transferable weight are values assuming the attached motor outputs the rated torque.  
 Note 4. When using in a clean environment, attach a suction air joint. The degree of cleanliness is the cleanliness level achieved when using at 1000 mm/sec or less.  
 Note 5. The required suction amount will vary according to the operating conditions and operating environment.

## Static loading moment

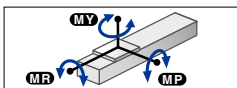

	MY	MP	MR
(Unit: N·m)	186	186	164

## Motor installation

The line-up consisting of six models of different motor installation position as follows.

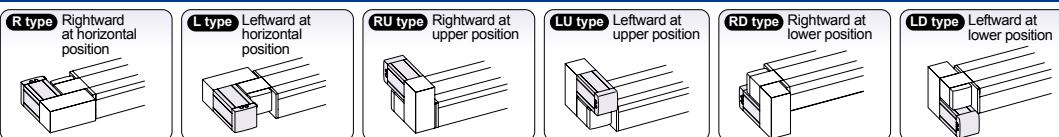

## Allowable overhang <sup>Note</sup>

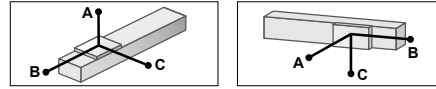

### LGBS10-30(100W)

	Horizontal installation (Unit: mm)			Wall installation (Unit: mm)		
	A	B	C	A	B	C
6kg	1284	621	522	6kg	570	408
9kg	1027	408	376	9kg	387	257
12kg	954	305	308	12kg	301	184

- Note. Distance from center of slider top to center of gravity of object being carried at a guide service life of 10,000 km.  
 Note. Service life is calculated for 1000 mm stroke models.  
 Note. When using it suspended from the ceiling, the overhang will be the same as when used horizontally.

## Allowable overhang <sup>Note</sup>

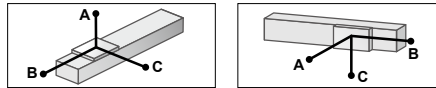

### LGBS10-50(200W)

	Horizontal installation (Unit: mm)			Wall installation (Unit: mm)		
	A	B	C	A	B	C
6kg	943	621	429	6kg	479	408
12kg	768	302	279	12kg	276	182
18kg	746	208	220	18kg	198	115

### LGBS10-30(200W)

	Horizontal installation (Unit: mm)			Wall installation (Unit: mm)		
	A	B	C	A	B	C
15kg	630	238	223	15kg	211	137
25kg	626	152	168	25kg	135	76
35kg	648	115	139	35kg	94	50

- Note. Distance from center of slider top to center of gravity of object being carried at a guide service life of 10,000 km.  
 Note. Service life is calculated for 1000 mm stroke models.  
 Note. When using it suspended from the ceiling, the overhang will be the same as when used horizontally.

▶ The cycle time simulation and service life calculation can be performed easily from our member site.

**Applicable motor**

**Applicable servo motor**

Motor specification	Flange size	Wattage	Manufacturer	Model
Y <sup>Note 1</sup>	□ 40	100W	Tamagawa Seiki	TSM4154N □ □ 00E200
			Yaskawa Electric Corp.	SGM7J-01
				SGMXJ-01
			Keyence Corp.	SV- □ 010
				SV2- □ 010
				SV3- □ 010
			Mitsubishi Electric Corp.	HG-KR13 <sup>Note 2</sup>
				HK-KT13 <sup>Note 2</sup>
				HK-MT13 <sup>Note 2</sup>
			Omron Electronics	R88M-K10030
R88M-1M10030 <sup>Note 2</sup>				
Panasonic Corp.	MHMF012			
	MHMG012			
T	□ 60	200W	Tamagawa Seiki	TSM4252N □ □ 00E200
			Yaskawa Electric Corp.	SGM7J-02
				SGMXJ-02
			Keyence Corp.	SV- □ 020
				SV2- □ 020
				SV3- □ 020
			Mitsubishi Electric Corp.	HG-KR23 <sup>Note 3</sup>
				HK-KT23 <sup>Note 3</sup>
HK-MT23 <sup>Note 3</sup>				
P	□ 60	200W	Omron Electronics	R88M-K20030
				R88M-1M20030
			Panasonic Corp.	MSMF022
				MHMF022
				MHMG022

Note 1. For the Y specification, only lead 30 is available.

Note 2. A special shim plate is required.

Part number of shim plate
KES-M2295-00

Note 3. A special shim plate is required.

Part number of shim plate
KEV-M2295-00

- Linear conveyor modules  
LCMR200
- Single-axis robots  
GX
- Linear conveyor modules  
LCM100
- SCARA robots  
YK-X
- Single-axis robots  
Robonity
- Linear motor single-axis robots  
PHASER
- Single-axis robots  
FLIP-X
- Compact single-axis robots  
TRANSERVO
- Cartesian robots  
XY-X
- Pick & place robots  
YP-X
- CLEAN
- CONTROLLER
- INFORMATION
- LBFS
- LBAS
- LGXS
- LBAR
- LGFS
- LBFS
- ABAS
- AGXS
- ABAR
- AGFS
- AGBS
- Option

# LGBS10

## LGBS10

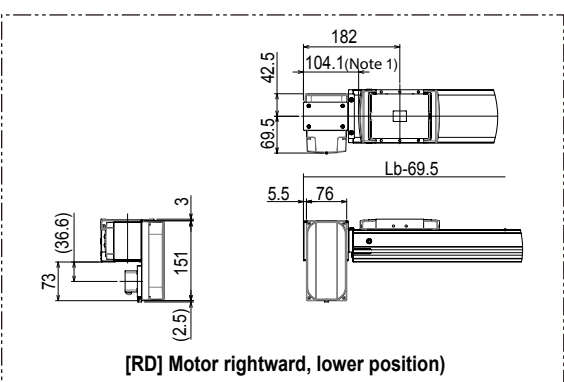
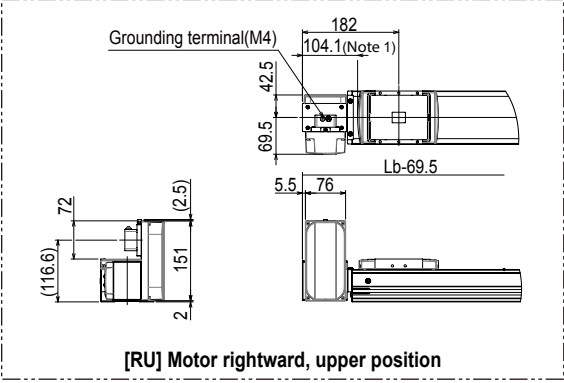
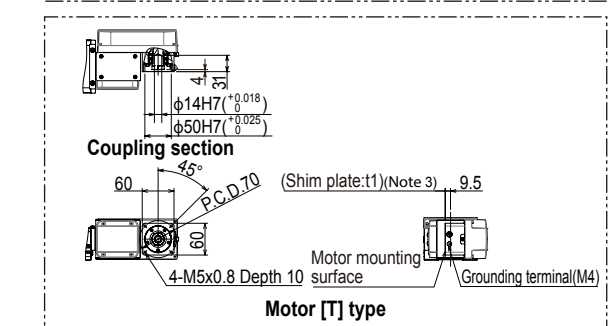
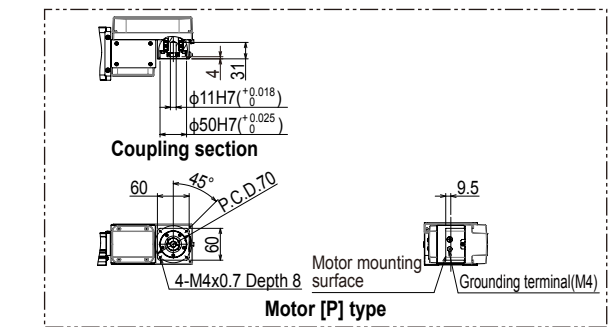
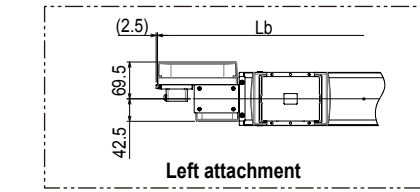
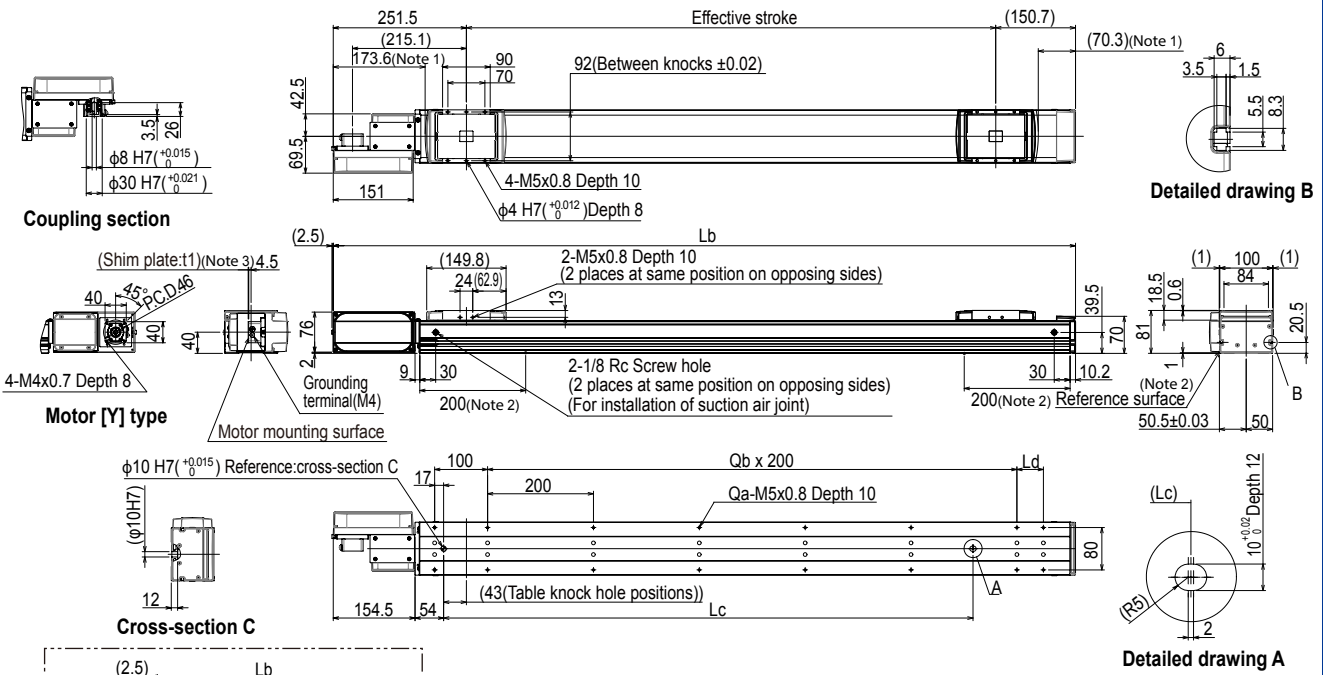

Note 1. Stop positions are determined by the mechanical stoppers at both ends.  
 Note 2. When the effective stroke is 2050 mm or more, the reference plane is within 200 mm of the frame end face.  
 Note 3. Depending on the motor you install, a shim plate may be required. For details, please refer to the Servo Motor Compatibility Table (p.217).  
 Note. In the installation tap hole, the length under head <<thickness of stand +10mm or less>> is recommended for the hex socket head bolts <M5x0.8> used to install the main unit.

Effective stroke	150	200	250	300	350	400	450	500	550	600	650	700	750	800	850	900	950	1000	1050	1100	1150	1200	1250	1300	1350	1400	1450	1500	1550			
Lb	552.2	602.2	652.2	702.2	752.2	802.2	852.2	902.2	952.2	1002.2	1052.2	1102.2	1152.2	1202.2	1252.2	1302.2	1352.2	1402.2	1452.2	1502.2	1552.2	1602.2	1652.2	1702.2	1752.2	1802.2	1852.2	1902.2	1952.2			
Lc	150	200	250	300	350	400	450	500	550	600	650	700	750	800	850	900	950	1000	1050	1100	1150	1200	1250	1300	1350	1400	1450	1500	1550			
Ld	200	50	100	150	200	50	100	150	200	50	100	150	200	50	100	150	200	50	100	150	200	50	100	150	200	50	100	150	200			
Qa	6	8	8	8	8	10	10	10	10	12	12	12	12	14	14	14	14	16	16	16	18	18	18	18	20	20	20	20	20			
Qb	0	1	1	1	1	2	2	2	2	3	3	3	3	4	4	4	4	5	5	5	6	6	6	6	7	7	7	7	7			
Weight (kg)	5.9	6.3	6.7	7.1	7.5	7.9	8.3	8.7	9	9.4	9.8	10.2	10.6	11	11.4	11.8	12.2	12.6	13	13.4	13.7	14.1	14.5	14.9	15.3	15.7	16.1	16.5	16.9			
Stroke restriction	No stroke restrictions																															
	To 2000st																															
	To 1500st																															
Effective stroke	1600	1650	1700	1750	1800	1850	1900	1950	2000	2050	2100	2150	2200	2250	2300	2350	2400	2450	2500	2550	2600	2650	2700	2750	2800	2850	2900	2950	3000			
Lb	2002.2	2052.2	2102.2	2152.2	2202.2	2252.2	2302.2	2352.2	2402.2	2452.2	2502.2	2552.2	2602.2	2652.2	2702.2	2752.2	2802.2	2852.2	2902.2	2952.2	3002.2	3052.2	3102.2	3152.2	3202.2	3252.2	3302.2	3352.2	3402.2			
Lc	1600	1650	1700	1750	1800	1850	1900	1950	2000	2050	2100	2150	2200	2250	2300	2350	2400	2450	2500	2550	2600	2650	2700	2750	2800	2850	2900	2950	3000			
Ld	50	100	150	200	50	100	150	200	50	100	150	200	50	100	150	200	50	100	150	200	50	100	150	200	50	100	150	200	50			
Qa	22	22	22	22	24	24	24	24	26	26	26	26	28	28	28	28	30	30	30	32	32	32	32	34	34	34	34	36				
Qb	8	8	8	8	9	9	9	9	10	10	10	10	11	11	11	11	12	12	12	13	13	13	13	14	14	14	14	15				
Weight (kg)	17.3	17.7	18.1	18.4	18.8	19.2	19.6	20	20.4	20.8	21.2	21.6	22	22.4	22.8	23.1	23.5	23.9	24.3	24.7	25.1	25.5	25.9	26.3	26.7	27.1	27.5	27.9	28.2			
Stroke restriction	No stroke restrictions																															
	To 2000st																															

# LGBS14

Advanced model **Motor-less Single Axis Actuator**

Timing Belt Drive type

## ■ 注文型式

### LGBS14

<b>Model</b>	<b>Lead</b> 50: 50 mm 30: 30 mm	<b>Shape</b> R: Motor rightward, horizontal position L: Motor leftward, horizontal position RU: Motor rightward, upper position LU: Motor leftward, upper position RD: Motor rightward, lower position LD: Motor leftward, lower position	<b>Motor specification</b> Y: Y specification (see below) P: P specification (see below) K: K specification (see below)	<b>OP.1</b> No entry: Standard M: Centerized lubrication	<b>Stroke</b> 150 to 4000 (50 mm pitch)
--------------	---------------------------------------	---	--	--	--

### [Caution]

This system is provided as mechanical actuator unit and not including any adopters or electric components. Motor, driver and other components required for installation are the user's responsibility. Refer to user's manual for installation details. Refer to your motor manual for tuning or adjustment. Vibration or resonance from actuator will affect service life of actuator. The product performance may not be satisfied depending on the compatible motor. For special parts for motor installation, install and adjust on your side.

## LGBS14 (200W)

### ■ Specifications

<b>Applicable motor</b>	200 W	
<b>Repeatability</b> <small>Note 1</small>	±0.04 mm	
<b>Stroke</b>	150 mm to 4000 mm (50 mm pitch)	
<b>Maximum Speed</b> <small>Note 2</small>	3750 mm/sec	2250 mm/sec
<b>Belt</b>	Equivalent to 50-mm Lead	Equivalent to 30-mm Lead
<b>Maximum payload</b> <small>Note 3</small>	Horizontal 8 kg	30 kg
<b>Maximum dimensions of cross section of main unit</b>	W 140 mm × H 83 mm	
<b>Overall length</b>	L/R Specifications	ST + 474.5 mm
	Other than the above	ST + 405 mm
<b>Degree of Cleanliness</b> <small>Note 4</small>	Equivalent to ISO Class 3 (ISO 14644-1)	
<b>Intake air</b> <small>Note 5</small>	90Nl/min	
<b>Using ambient temperature and humidity</b>	0 to 40 °C, 35 to 80 %RH (no condensation)	

- Note 1. Positioning repeatability in one direction.  
 Note 2. When a moving distance is short and depending on an operation condition, it may not reach the maximum speed.  
 Note 3. The rated thrust and maximum transferable weight are values assuming the attached motor outputs the rated torque.  
 Note 4. When using in a clean environment, attach a suction air joint. The degree of cleanliness is the cleanliness level achieved when using at 1000 mm/sec or less.  
 Note 5. The required suction amount will vary according to the operating conditions and operating environment.

### ■ Static loading moment

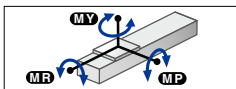

(Unit: N·m)		
MY	MP	MR
537	537	472

## LGBS14 (400W)

### ■ Specifications

<b>Applicable motor</b>	400 W	
<b>Repeatability</b> <small>Note 1</small>	±0.04 mm	
<b>Stroke</b>	150 mm to 4000 mm (50 mm pitch)	
<b>Maximum Speed</b> <small>Note 2</small>	3750 mm/sec	2250 mm/sec
<b>Belt</b>	Equivalent to 50-mm Lead	Equivalent to 30-mm Lead
<b>Maximum payload</b> <small>Note 3</small>	Horizontal 30 kg	60 kg
<b>Maximum dimensions of cross section of main unit</b>	W 140 mm × H 83 mm	
<b>Overall length</b>	L/R Specifications	ST + 474.5 mm
	Other than the above	ST + 405 mm
<b>Degree of Cleanliness</b> <small>Note 4</small>	Equivalent to ISO Class 3 (ISO 14644-1)	
<b>Intake air</b> <small>Note 5</small>	90Nl/min	
<b>Using ambient temperature and humidity</b>	0 to 40 °C, 35 to 80 %RH (no condensation)	

- Note 1. Positioning repeatability in one direction.  
 Note 2. When a moving distance is short and depending on an operation condition, it may not reach the maximum speed.  
 Note 3. The rated thrust and maximum transferable weight are values assuming the attached motor outputs the rated torque.  
 Note 4. When using in a clean environment, attach a suction air joint. The degree of cleanliness is the cleanliness level achieved when using at 1000 mm/sec or less.  
 Note 5. The required suction amount will vary according to the operating conditions and operating environment.

### ■ Static loading moment

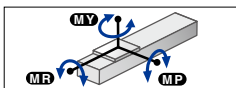

(Unit: N·m)		
MY	MP	MR
537	537	472

### ■ Motor installation

The line-up consisting of six models of deferent motor installation position as follows.

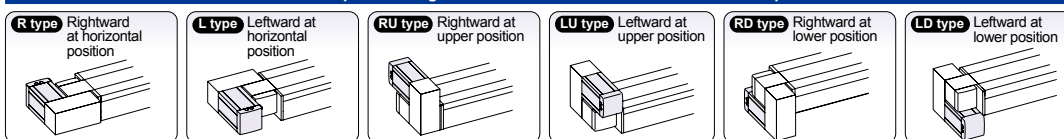

▶ The cycle time simulation and service life calculation can be performed easily from our member site.

### ■ Allowable overhang Note

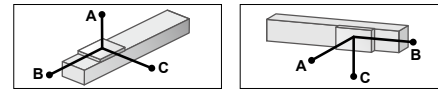

#### LGBS14-50(200W)

	Horizontal installation (Unit: mm)			Wall installation (Unit: mm)		
	A	B	C	A	B	C
4kg	4595	3295	2628	4kg	2664	3259
6kg	4027	2188	2007	6kg	2051	2151
8kg	3739	1634	1647	8kg	1696	1598

#### LGBS14-30(200W)

	Horizontal installation (Unit: mm)			Wall installation (Unit: mm)		
	A	B	C	A	B	C
10kg	2334	1302	1236	10kg	1237	1265
20kg	1641	637	670	20kg	675	601
30kg	1601	442	519	30kg	517	405

- Note. Distance from center of slider top to center of gravity of object being carried at a guide service life of 10,000 km.  
 Note. Service life is calculated for 1000 mm stroke models.  
 Note. When using it suspended from the ceiling, the overhang will be the same as when used horizontally.

### ■ Allowable overhang Note

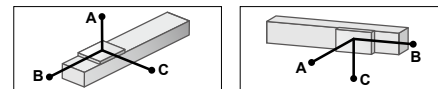

#### LGBS14-50(400W)

	Horizontal installation (Unit: mm)			Wall installation (Unit: mm)		
	A	B	C	A	B	C
10kg	943	621	429	10kg	479	408
20kg	768	302	279	20kg	276	182
30kg	746	208	220	30kg	198	115

#### LGBS14-30(400W)

	Horizontal installation (Unit: mm)			Wall installation (Unit: mm)		
	A	B	C	A	B	C
20kg	1519	637	652	20kg	653	601
40kg	1501	344	424	40kg	414	308
60kg	1596	250	332	60kg	309	213

- Note. Distance from center of slider top to center of gravity of object being carried at a guide service life of 10,000 km.  
 Note. Service life is calculated for 1000 mm stroke models.  
 Note. When using it suspended from the ceiling, the overhang will be the same as when used horizontally.

Linear conveyor modules  
 Single-axis robots  
 Linear conveyor modules  
 SCARA robots  
 Single-axis robots  
 Single-axis robots  
 Single-axis robots  
 Single-axis robots  
 Compact single-axis robots  
 Cartesian robots  
 Pick & place robots  
 CLEAN CONTROLLER INFORMATION  
 LBFS LBAS  
 LGXS LBAR  
 LGBS LGFS  
 ABFS ABAS  
 AGXS ABAR  
 AGBS AGFS  
 Option

## ■ Applicable motor

### ● Applicable servo motor

Motor specification	Flange size	Wattage	Manufacturer	Model
Y	□ 60	200W	Tamagawa Seiki	TSM4252N □ □ 00E200
			Yaskawa Electric Corp.	SGM7J-02
				SGMJX-02
			Keyence Corp.	SV- □ 020
				SV2- □ 020
				SV3- □ 020
		Mitsubishi Electric Corp.	HG-KR23 <sup>Note 1</sup>	
			HK-KT23 <sup>Note 1</sup>	
			HK-MT23 <sup>Note 1</sup>	
		400W	Tamagawa Seiki	TSM4254N □ □ 00E200
			Yaskawa Electric Corp.	SGM7J-04
				SGMJX-04
Keyence Corp.	SV- □ 040			
	SV2- □ 040			
Mitsubishi Electric Corp.	SV3- □ 040			
	HG-KR43 <sup>Note 1</sup>			
HK-KT43 <sup>Note 1</sup>	HK-KT43 <sup>Note 1</sup>			
	HK-MT43 <sup>Note 1</sup>			
500W	□ 60	Fanuc Corp.	βiS1/6000-B <sup>Note 1</sup>	
P	□ 60	200W	Omron Electronics	R88M-K20030
			R88M-1M20030	
		Panasonic Corp.	MSMF022	
			MHMF022	
MHMG022				
	400W	Omron Electronics	R88M-K40030	
R88M-1M40030				
Panasonic Corp.	MSMF042			
	MHMF042			
MHMG042				
K	□ 60	400W	Omron Electronics	R88M-K40030
			R88M-1M40030	
Panasonic Corp.	MSMF042			
MHMF042				
MHMG042				

Note 1. A special shim plate is required.

Part number of shim plate
KEV-M2295-00

Linear conveyor modules  
LCMR200

Single-axis robots  
GX

Linear conveyor modules  
LCM100

SCARA robots  
YK-X

Single-axis robots  
Robonity

Linear motor single-axis robots  
PHASER

Single-axis robots  
FLIP-X

Compact single-axis robots  
TRANSERO

Cartesian robots  
XY-X

Pick & place robots  
YP-X

CLEAN

CONTROLLER

INFORMATION

LBAS

LBFS

LBAR

LGXS

LGBS

LGFS

ABAS

ABFS

ABAR

AGXS

AGFS

AGBS

Option

## LGBS14

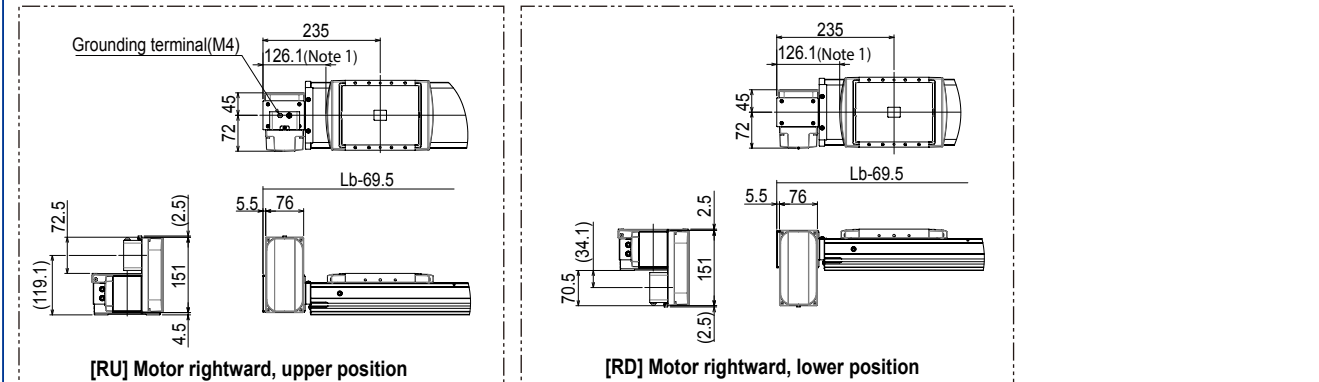
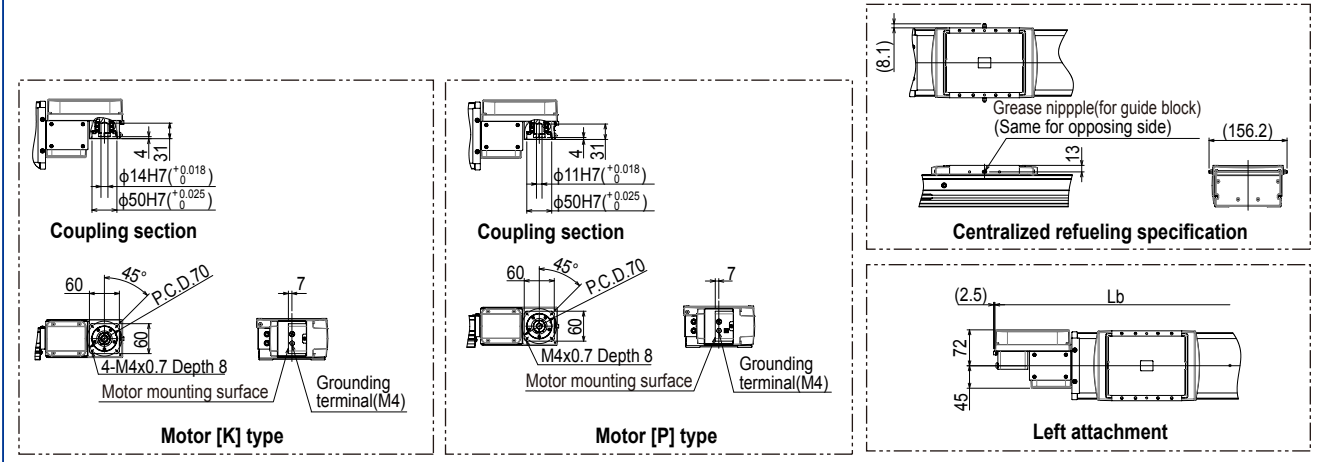
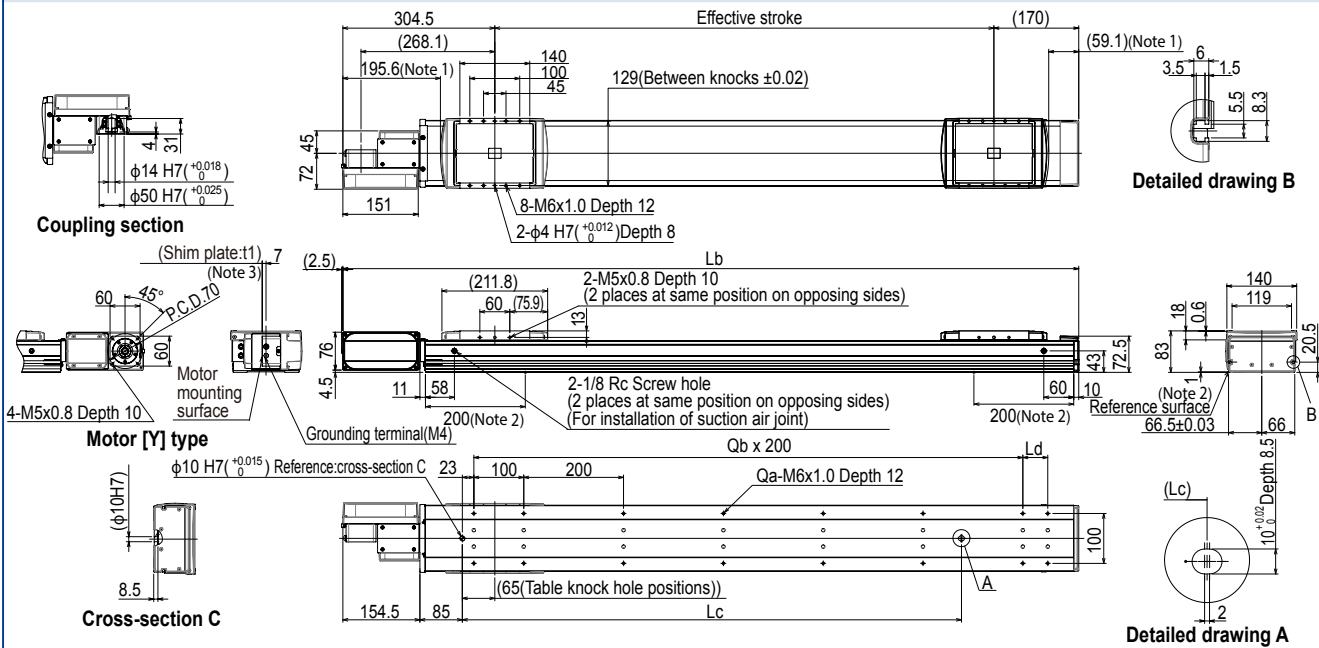

**[RU] Motor rightward, upper position**

**[RD] Motor rightward, lower position**

Note 1. Stop positions are determined by the mechanical stoppers at both ends.  
 Note 2. When the effective stroke is 2050 mm or more, the reference plane is within 200 mm of the frame end face.  
 Note 3. Depending on the motor you install, a shim plate may be required. For details, please refer to the Servo Motor Compatibility Table (p. 220).  
 Note. In the installation tap hole, the length under head <<thickness of stand +10mm or less>> is recommended for the hex socket head bolts <M5×0.8> used to install the main unit.

Effective stroke	150	200	250	300	350	400	450	500	550	600	650	700	750	800	850	900	950	1000	1050	1100	1150	1200	1250	1300	1350	1400	1450	1500	1550	1600	1650	1700	1750	1800	1850	1900	1950	2000	2050	
Lb	624.5	674.5	724.5	774.5	824.5	874.5	924.5	974.5	1024.5	1074.5	1124.5	1174.5	1224.5	1274.5	1324.5	1374.5	1424.5	1474.5	1524.5	1574.5	1624.5	1674.5	1724.5	1774.5	1824.5	1874.5	1924.5	1974.5	2024.5	2074.5	2124.5	2174.5	2224.5	2274.5	2324.5	2374.5	2424.5	2474.5	2524.5	
Lc	150	200	250	300	350	400	450	500	550	600	650	700	750	800	850	900	950	1000	1050	1100	1150	1200	1250	1300	1350	1400	1450	1500	1550	1600	1650	1700	1750	1800	1850	1900	1950	2000	2050	
Ld	200	50	100	150	200	50	100	150	200	50	100	150	200	50	100	150	200	50	100	150	200	50	100	150	200	50	100	150	200	50	100	150	200	50	100	150	200	50	100	
Qa	6	8	8	8	8	10	10	10	10	12	12	12	12	14	14	14	14	16	16	16	16	18	18	18	18	18	20	20	20	22	22	22	22	24	24	24	24	24	26	26
Qb	0	1	1	1	1	2	2	2	2	3	3	3	3	4	4	4	4	5	5	5	5	6	6	6	6	7	7	7	7	8	8	8	8	9	9	9	9	10	10	
Weight (kg)	8.6	9.1	9.5	10.0	10.4	10.9	11.4	11.8	12.3	12.7	13.2	13.7	14.1	14.6	15.0	15.5	16.0	16.4	16.9	17.3	17.8	18.2	18.7	19.2	19.6	20.1	20.5	21.0	21.5	21.9	22.4	22.8	23.3	23.8	24.2	24.7	25.1	25.6	26.1	
Stroke restriction	No stroke restrictions																																							
	Horizontal-Vertical															To 1500st																								
	Wall hanging															To 2000st																								
	Ceiling-mounted															To 1500st																								

Effective stroke	2100	2150	2200	2250	2300	2350	2400	2450	2500	2550	2600	2650	2700	2750	2800	2850	2900	2950	3000	3050	3100	3150	3200	3250	3300	3350	3400	3450	3500	3550	3600	3650	3700	3750	3800	3850	3900	3950	4000	
Lb	2574.5	2624.5	2674.5	2724.5	2774.5	2824.5	2874.5	2924.5	2974.5	3024.5	3074.5	3124.5	3174.5	3224.5	3274.5	3324.5	3374.5	3424.5	3474.5	3524.5	3574.5	3624.5	3674.5	3724.5	3774.5	3824.5	3874.5	3924.5	3974.5	4024.5	4074.5	4124.5	4174.5	4224.5	4274.5	4324.5	4374.5	4424.5	4474.5	
Lc	2100	2150	2200	2250	2300	2350	2400	2450	2500	2550	2600	2650	2700	2750	2800	2850	2900	2950	3000	3050	3100	3150	3200	3250	3300	3350	3400	3450	3500	3550	3600	3650	3700	3750	3800	3850	3900	3950	4000	
Ld	150	200	50	100	150	200	50	100	150	200	50	100	150	200	50	100	150	200	50	100	150	200	50	100	150	200	50	100	150	200	50	100	150	200	50	100	150	200	50	100
Qa	26	26	28	28	28	28	30	30	30	30	32	32	32	34	34	34	34	36	36	36	36	38	38	38	38	38	40	40	40	42	42	42	42	44	44	44	44	44	46	
Qb	10	10	11	11	11	11	12	12	12	12	13	13	13	13	14	14	14	14	15	15	15	15	16	16	16	16	16	17	17	17	17	18	18	18	18	19	19	19	19	20
Weight (kg)	26.5	27.0	27.4	27.9	28.3	28.8	29.3	29.7	30.2	30.6	31.1	31.6	32.0	32.5	32.9	33.4	33.9	34.3	34.8	35.2	35.7	36.1	36.6	37.1	37.5	38	38.4	38.9	39.4	39.8	40.3	40.7	41.2	41.7	42.1	42.6	43	43.5	44	
Stroke restriction	No stroke restrictions																																							
	Horizontal-Vertical															To 1500st																								
	Wall hanging															To 2000st																								
	Ceiling-mounted															To 1500st																								

- Linear conveyer modules LCMR200
- Single-axis robots GX
- Linear conveyer modules LCM100
- SCARA robots YK-X
- Single-axis robots Robomity
- Linear motor PHASER
- Single-axis robots FLIP-X
- Compact single-axis robots TRANSERO
- Cartesian robots XX-X
- Pick & place robots YP-X
- CLEAN
- CONTROLLER INFORMATION
- LBFS
- LBAS
- LBAR
- LGBS
- LGFS
- LGAS
- ABFS
- ABAS
- ABAR
- AGFS
- AGAS
- Option