

iVY2 System

Product Lineup

ROBOT VISION iVY2 RCX340

Integrated Robot Vision System with "plug-and-play" simplicity
Basic specifications have been dramatically enhanced while retaining the current iVY system's ease of use.



Simplicity

Setup is completed as little as eight minutes after power-on.
Auto-calibration makes setup easy.

Sophistication

With up to five million pixels, a variety of workpieces can be supported.
Improve throughput to 100 CPM with conveyor tracking.

Assurance

Comprehensive support covers everything from camera image acquisition to the operation of the gripper and robot.
With support that only the robot manufacturer can provide, you can relax.

Basic specifications have been dramatically enhanced while retaining the current iVY system's ease of use.

Camera Supports from 300,000 to 5 million pixels Megapixel camera support	Number of registered types Increased to 254 types Previously 40 types	Shorter search time Approximately 50 % less With capture: 30–40% less Search only: approximately 50% less <small>Note. Time depends on the workpiece.</small>	Longer cables usable Cables can be as long as 20 m Previously 9.5 m	Monitoring Monitor output is provided Enables operating status to be monitored without a PC
--	--	--	--	---

iVY2 System configuration illustration

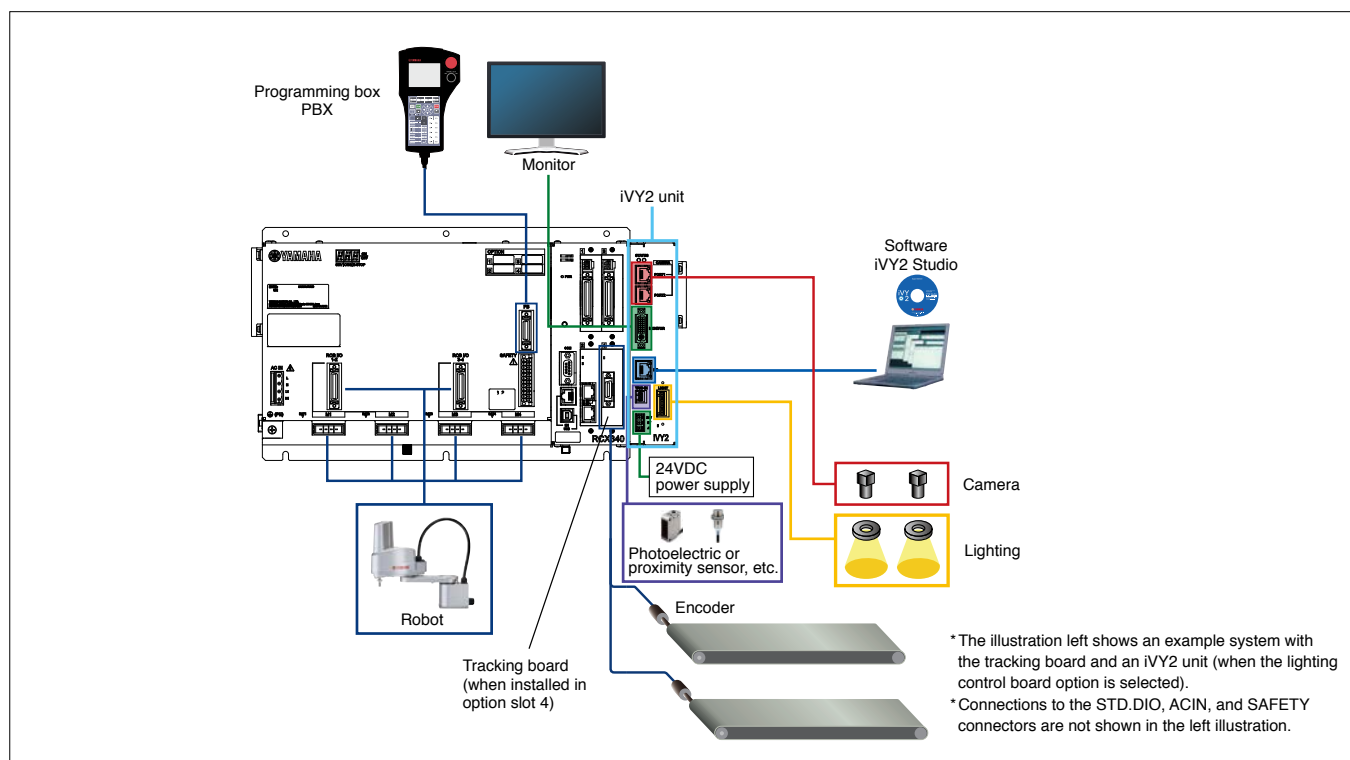

POINT 1

Various application examples

- **Labeling device** (affixing labels to food packages)
- **Sealant touch-up** (engine block sealant)
- **Screw attachment position detection** (television panel screw attachment)
- **Position compensation with upward-facing camera** (installing irregularly-shaped parts on a circuit board)

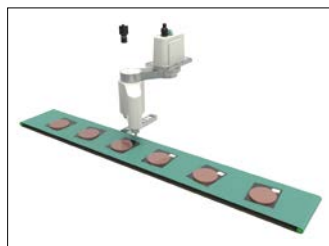

■ Industry: food
 ■ Robot used: YK500TW omnidirectional robot

Even if the incoming workpieces are irregularly spaced or positioned, labels can be affixed at the same position.



■ Industry: automotive
 ■ Robot used: SXYX Cartesian robot

Even if the workpiece is skewed from its correct position, the skew and angle are detected, and the application path is automatically compensated.

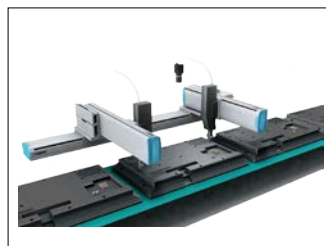

■ Industry: electronics
 ■ Robot used: NXY Cartesian robot

Hole position is detected, and screws are fastened accurately.

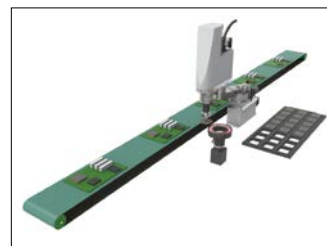

■ Industry: electronics
 ■ Robot used: YK150XG SCARA robot

The roughly-positioned circuit board connector is picked up, the upward-facing camera is used to apply position compensation, and the part is mounted directly on the circuit board.

POINT 2

Auto-calibration

Easily complete high-precision calibration just by following a wizard! Even if equipment becomes misaligned, execute auto-calibration and resume operation.

Requires as little as **5 minutes**

STEP 1

Register the desired fiducial mark



STEP 2

Select the camera mounting method

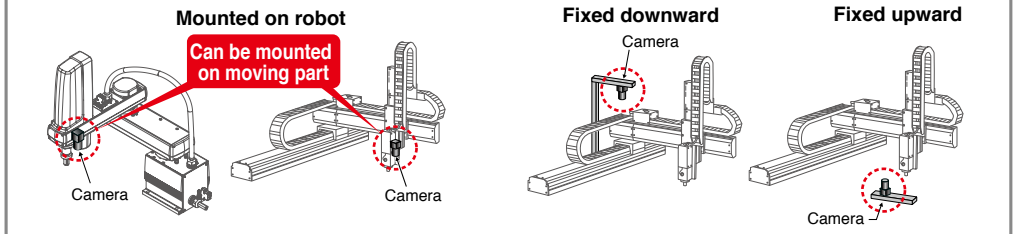

POINT 3

Easy workpiece registration

From image acquisition, registration takes just three steps.

Requires as little as **3 minutes**

STEP 1

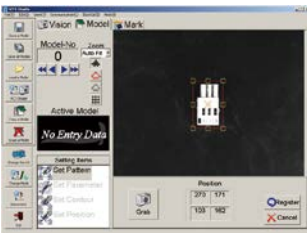

Capture images.

Put the workpiece within the camera field-of-view and specify an image capturing range.

STEP 2

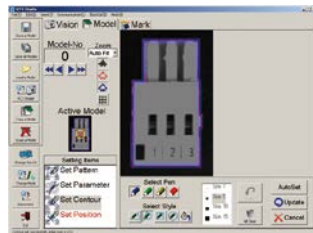

Set the contour.

Contour is automatically extracted. Paint the necessary contour with a pen tool.

STEP 3

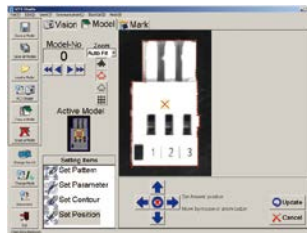

Register the detection position.

Specify the detection position with the mouse. Desired positions can be set.

Search results

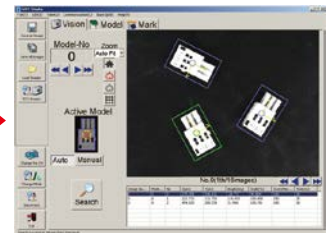

POINT 4

No need to make time-consuming connection settings. Dramatic reduction in setup time.

From image acquisition, registration takes just three steps.

Comparison of setup time

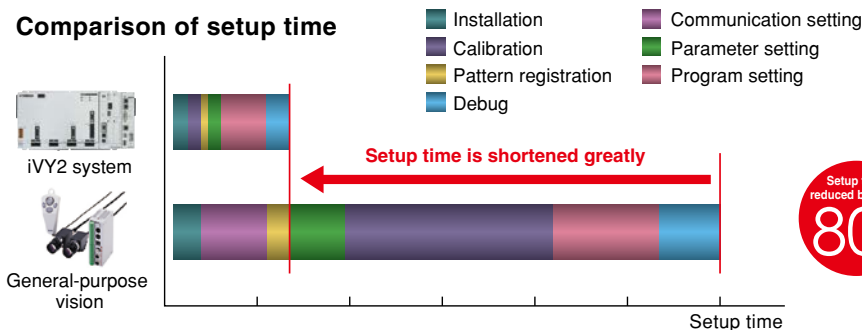

STEP 3

Align fiducial mark position

If camera is movable, move the robot

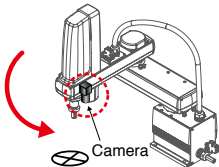

If camera is fixed, attach fiducial mark to robot, and move it

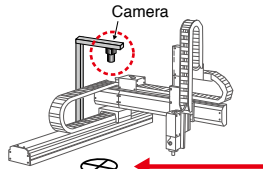

Execute auto-calibration

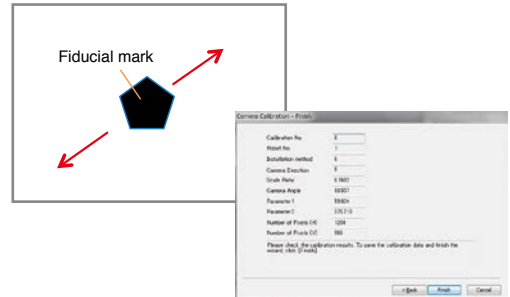

POINT 5

No need to create a coordinate conversion program.

Dedicated robot language for vision is provided.

General robot vision

```

MOVE P, P9
OFF LINE
SEND (* *) TO CMU
SEND CMU TO P10
ON LINE
MOVE P, P10
    
```

Communication with image processing unit

RS-232C

Program of image processing unit

Program of host PLC

Camera and robot have separate programs

iVY2 system

```

MOVE P, P9
VSEARCH 1,2,0
P10=VGETPOS(0)
MOVE P, P10
    
```

Searches for workpiece.
Reads the point.
Moves to this point.



MERITS

- No communication time lag
- Needs only few command lines.
- Simple and easy to understand

Centralized control using only the robot program

POINT 6

Easy inter-operation with peripheral equipment

The same controller provides unified control of robot, gripper, and lighting.

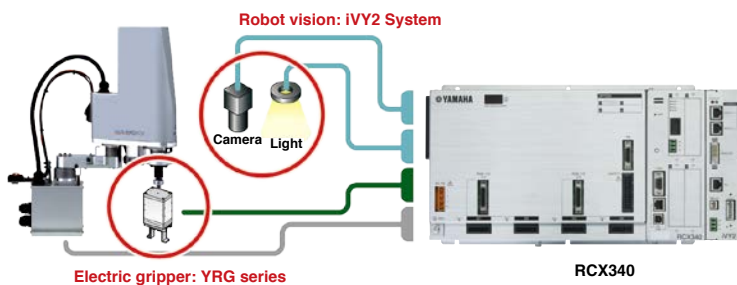

POINT 7

Also supports moving camera

Even if the camera is mounted on the robot, coordinates are automatically converted according to the robot's movement.

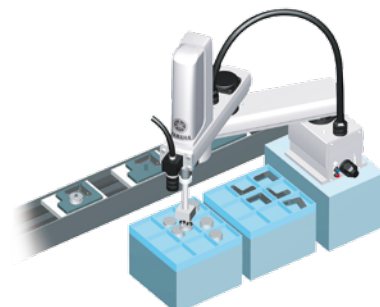

Conveyor tracking reaches **100** CPM per unit

POINT 8

Conveyor tracking

Ideal for high-speed packaging arrangement high-speed transport of multiple types of items such as pharmaceuticals, cosmetics, and food products.

The vision camera detects the position and orientation of parts moving on the conveyor, and the robot picks them up.

Previous RCX240 controller		New RCX340 controller	
Example program (RCX240)			
① PTP command	MOVE P,P1	Executed using multiple operation commands	Unify movement commands
② CTMOVE	CTMOVE (1)		
③ CTDRIIVE	CTDRIIVE(10.0)		
Multiple operating takt required		Example program (RCX340)	
		① New CTMOVE CTMOVE (1),Z=0.0,CTZ=10.0	
		Can be executed with a single command	
		Unify the move up command, follow workpiece command, move down command	

Reduce operating takt

Operating conditions: YK500XG / payload 1 kg (total of workpiece and tool) / horizontal movement 250 mm / vertical movement 1 mm / conveyor speed 100 mm/sec

POINT 9

Control multiple robots for even more improvement in production efficiency.

Shortened cycle time Improve throughput

RCX340 + iVY2

RCX340

Tracking board

YC-Link/E

Connect up to four units
100 CPM/unit x 4 units (maximum 400 CPM)

Program allows differentiation by model for even more improvement in production efficiency

Information from a single camera can be shared by multiple robots

Control two robots to let downstream robot handle missed items

Conveyor direction

POINT 10

Approximately double the search speed (compared to previous model)

Even a large number of workpieces can be detected at high speed. The search speed is approximately double that of the previous model. This can be used for a wide variety of applications, including molded plastic parts or food items.

Sample workpiece ① Connector-shaped workpiece

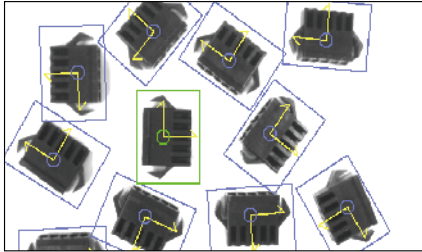

RCX240 + iVY 158.7 ms
RCX340 + iVY2 83.8 ms

Sample workpiece ② Washer-shaped workpiece

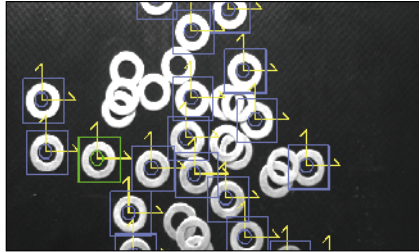

RCX240 + iVY 200.2 ms
RCX340 + iVY2 91.7 ms

Sample workpiece ③ Food item workpiece

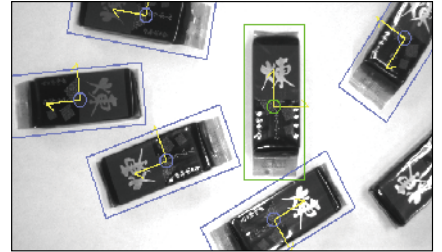

RCX240 + iVY 149.8 ms
RCX340 + iVY2 91.1 ms

POINT 11

Support for five-megapixel cameras

(Choose from 300,000 pixel, 1.3 megapixel, and 2 megapixel, and 5 megapixel)

- Stable workpiece detection
- Decreased number of search detections

Detailed edge detection is possible even if workpieces are touching each other or have a complex shape.

- Previous: 300,000 pixel camera
- New: 1.3 megapixel camera

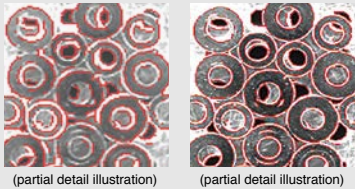

A single search allows detection even for a large workpiece, improving takt.

- Previous: 300,000 pixel camera
- New: two-megapixel camera

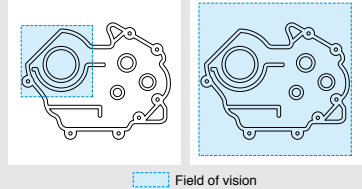

POINT 12

254 types can be registered

Setup changes require only that part numbers be changed. Setup changes are easy.

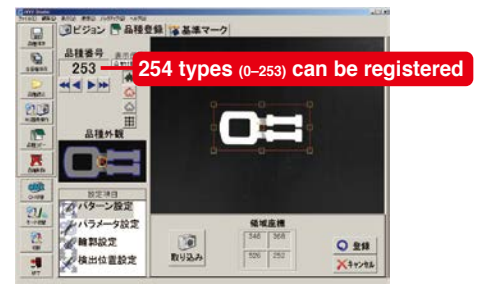

POINT 13

Monitor output is provided

- Monitor the operating status

Monitor the search status while making calibration settings or during automatic operation.

Contents of output

- Selected type / Captured image
- Search result (position, score, scale)
- Executed command
- Time required by command

Output method

- DVI-I (supports digital monitor or analog monitor)



POINT 14

High-precision search even under low light

- Edge search engine is built-in

Supports a variety of applications while being minimally affected by the external environment.

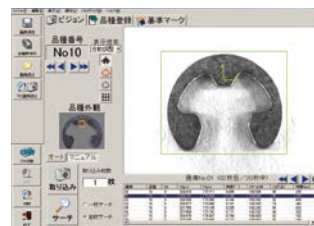

When lighting is sufficient

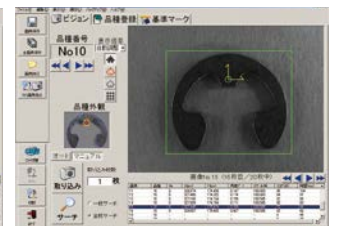

Accurate search even if lighting is insufficient

POINT 15

Preparatory evaluation and advice give you peace of mind

We borrow the workpiece from you, evaluate it, and submit an evaluation report.

In addition, we draw on our wealth of experience and evaluation results to provide advice and training regarding selection and installation of robots and peripheral equipment.

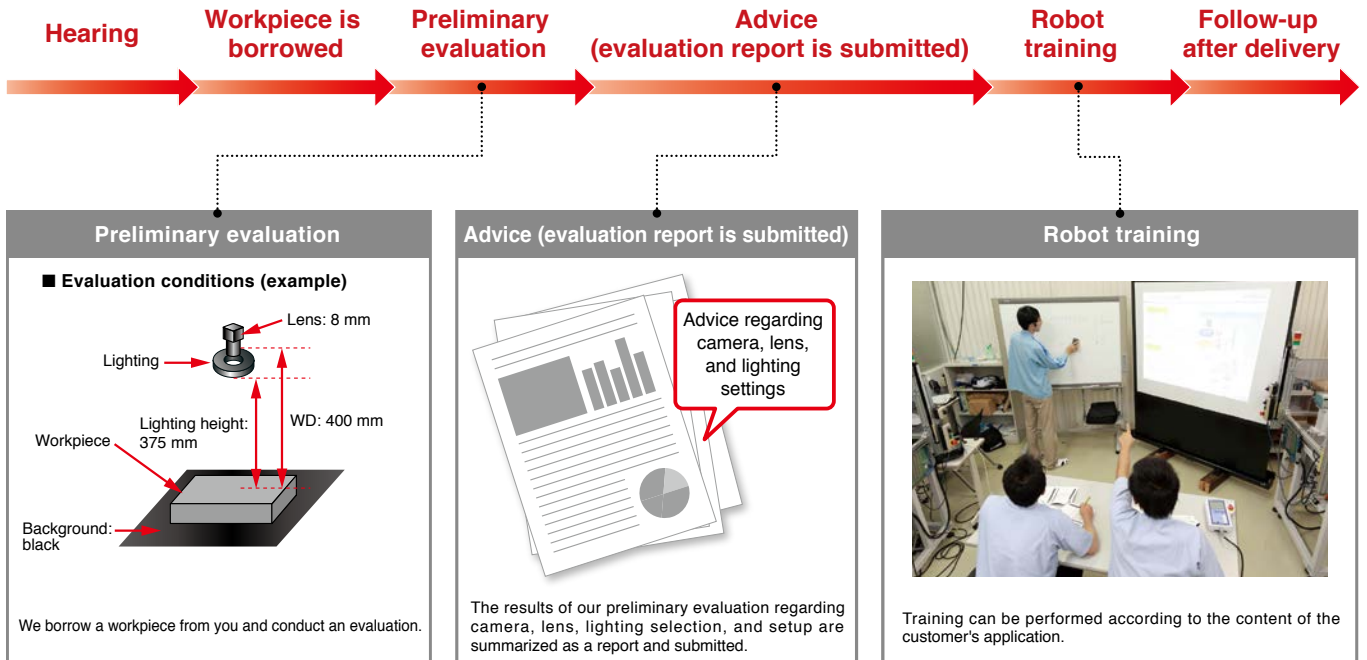

POINT 16

Choose freely from Yamaha's lineup of robots

A low-cost and convenient robot vision system can be constructed using the models that are optimal for the customer's application.

■ XY-X Cartesian robots



■ YK-XG SCARA robots



■ YK-TW orbit type robots



■ FLIP-X single-axis robots



Note. The YA series is not supported.

iVY2 System

Applicable controllers ▶ RCX340

● Robot with image processing functions

Integrated Robot Vision System with “plug-and-play” simplicity.
Basic specifications have been dramatically enhanced while retaining the current iVY system’s ease of use.



■ Main functions ▶ P.70

■ Ordering method

RCX340					
Controller	No. of controllable axes	Safety standards	Controller option A to D (OP.A to D) <small>TR: Tracking</small>	Controller option E (OP.E) <small>No entry: Non-selection VY: iVY2 without light VL: iVY2 with light</small>	Absolute battery

Note. For details on the various selection items, refer to P.521

■ Basic specifications

● Robot vision basic specifications

Item		iVY2 unit
Basic specifications	Applicable controllers	RCX340
	Number of screen pixels	648(H) × 494(V) (300,000 pixels, VGA) 1280(H) × 966(V) (1,300,000 pixels, SXGA) 1624(H) × 1236(V) (2,000,000 pixels, UXGA) 2592(H) × 1944(V) (5,000,000 pixels, QSXGA)
	Model setting capacity	254 models
	Number of connectable cameras	Max. 2 cameras
	Connectable camera	GigE camera (VGA, SXGA, UXGA) PoE: IEEE802.3af 1 ch up to 7W
	External interface	Ethernet (1000BASE-T) Note. For setting and monitor operations
	External monitor output	DVI-I Note. Also usable with an analog monitor by using a conversion adaptor. Monitor resolution: 1024 × 768
	Power supply	DC24V +/-10% 1.5A Max.
	Dimensions	W45 × H195 × D130 (iVY2 unit only)
	Weight	0.8kg (iVY2 unit only, when the lighting control board option is selected)
Search method		Edge search (correlated edge filter, Sobel filter)
Image capturing	Trigger mode	S/W trigger, H/W trigger
	External trigger input	2 points
Function		Position detection, automatic point data generation
Camera installation position		Fixed to the fixed camera (up, down) or robot (Y-axis, Z-axis). Perpendicular to the workpiece to be captured.
Setting support function		Calibration, image save function, model registration ^{Note} , fiducial mark registration ^{Note} , monitor function ^{Note} Note. iVY2 Studio function (requires a Windows PC)
Lighting control options	Number of connectable lighting units	Max. 2 lighting units
	Modulated light format	PWM modulated light control (0 to 100%), PWM frequency switchable 62.5 kHz/125 kHz Continuous light, strobe light (follows camera exposure)
	Lighting power input	12VDC or 24VDC (external supply shared by both channels)
	Lighting output	For 12VDC supply: Total of less than 40W for both channels. For 24VDC supply: Total of less than 80W for both channels.

System configuration illustration

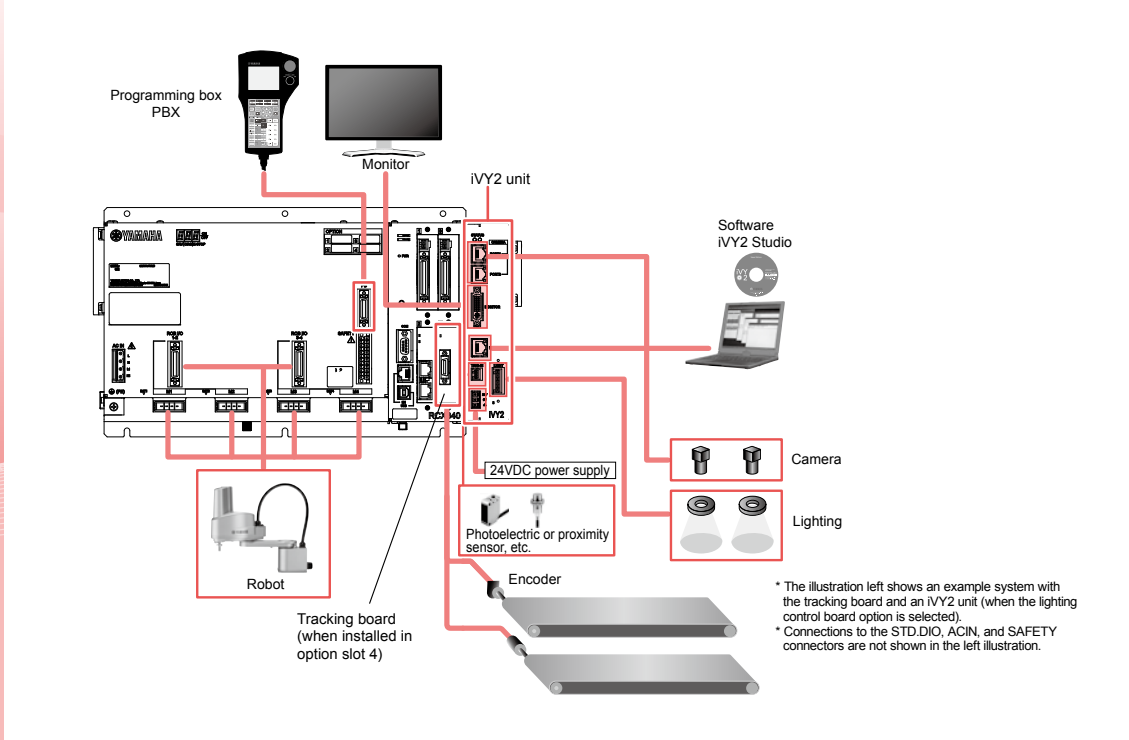

Tracking board basic Specifications

Item		Tracking board
Basic specifications	Applicable controllers	RCX340
	Number of connected encoders	Up to 2 units.
	Encoder power supply	5VDC (2 counters total 500 mA or less) (Supplied from controller)
	Applicable encoder	26LS31/26C31 or equivalent line driver (RS-422 compliance).
	Input phase	A, \bar{A} , B, \bar{B} , Z, \bar{Z}
	Max. response frequency	2MHz or less
	Counter	0 to 65535
	Multiplier	4x
	Other	With disconnection detection function

Dimensional outlines

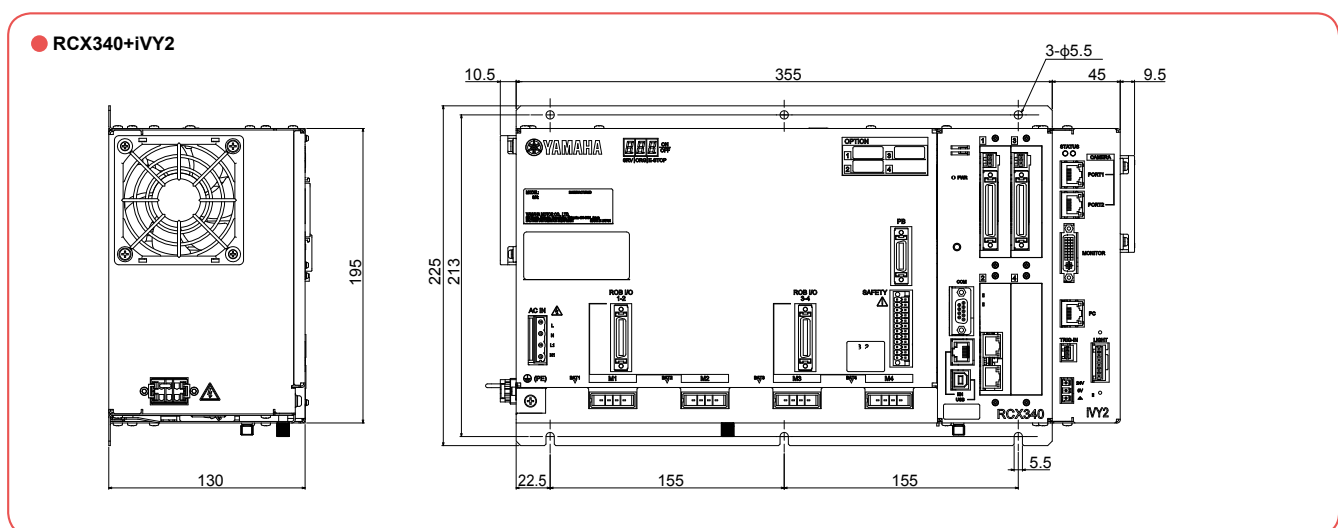

APPLICATION
 YA
 TRANSEURO
 FLIP-X
 PHASER
 XY-X
 YK-X
 YP-X
 CLEAN
 CONTROLLER
 INFORMATION
 Robot positioner
 Pulse string driver
 Robot controller
 iVY2
 Option

Dimensional outlines

● CCD camera

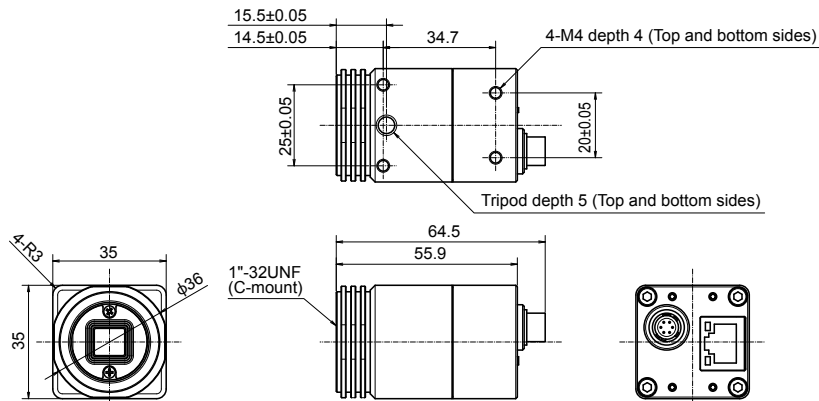

● Lenses

● 8mm lens

(Model No. : KCX-M7214-00)

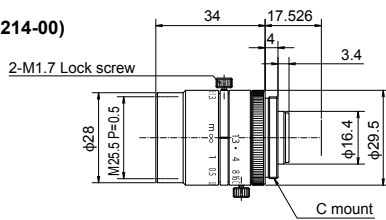

● 8mm lens (megapixel support)

(Model No. : KCX-M7214-40)

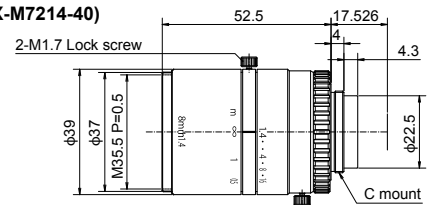

● 12mm lens

(Model No. : KCX-M7214-10)

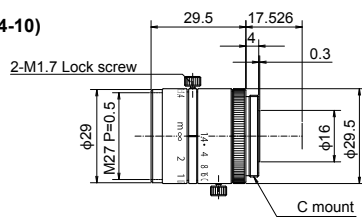

● 12mm lens (megapixel support)

(Model No. : KCX-M7214-50)

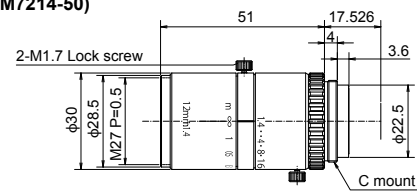

● 16mm lens

(Model No. : KCX-M7214-20)

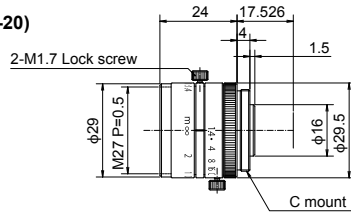

● 16mm lens (megapixel support)

(Model No. : KCX-M7214-60)

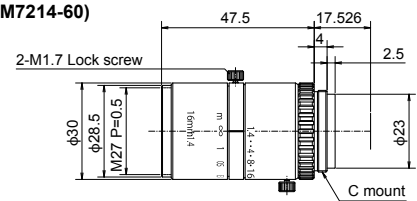

● 25mm lens

(Model No. : KCX-M7214-30)

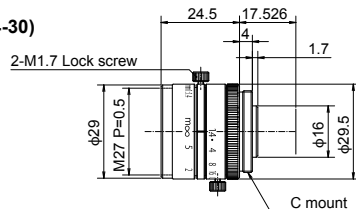

● 25mm lens (megapixel support)

(Model No. : KCX-M7214-70)

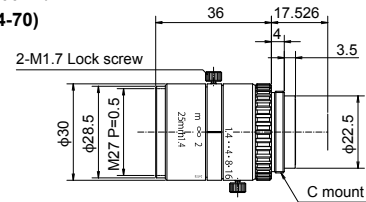

■ Lens characteristics

Lens	Model	Focal length [mm]	Aperture value [F No.]	Angle-of-view (degrees)		Angle-of-view (degrees)		Closest approach distance [m]
				With 1/3 inch sensor KCX-M6541-00 (300,000 pixel camera) KCX-M6541-10 (1,300,000 pixel camera)		With 1/1.8 inch sensor KCX-M6541-20 (2,000,000 pixel camera)		
				Vertical	Horizontal	Vertical	Horizontal	
8mm	KCX-M7214-00	8	F1.3—CLOSE	25.21	33.2	37.08	47.59	0.2
12mm	KCX-M7214-10	12	F1.4—CLOSE	16.48	21.86	24.51	31.88	0.3
16mm	KCX-M7214-20	16	F1.4—CLOSE	12.57	16.71	18.77	24.51	0.4
25mm	KCX-M7214-30	25	F1.4—CLOSE	8.18	10.89	12.25	16.06	0.5
8mm (megapixel support)	KCX-M7214-40	8	F1.4—F16	25.36	33.4	37.3	47.86	0.1
12mm (megapixel support)	KCX-M7214-50	12	F1.4—F16	16.65	22.08	24.76	32.2	0.1
16mm (megapixel support)	KCX-M7214-60	16	F1.4—F16	12.68	16.85	18.92	24.72	0.1
25mm (megapixel support)	KCX-M7214-70	25	F1.4—F16	8.24	10.97	12.33	16.16	0.15

Note. This table shows the angle-of-view for Yamaha's standard lenses. If the angle-of-view is greater, there might be more distortion at the edge of the image.

■ Angle-of-view size, WD, and magnification when close-up ring is used

Close-up ring [mm]			Lens			
			8 mm KCX-M7214-00	12 mm KCX-M7214-10	16 mm KCX-M7214-20	25 mm KCX-M7214-30
None	Angle-of-view size X × Y [mm]	WD [mm]	200	300	400	500
		KCX-M6541-00 (300,000 pixels)	96.2 × 126.2	91.4 × 119.9	91.4 × 119.9	71.7 × 94.1
	KCX-M6541-10 (1,300,000 pixels)	95.4 × 126.4	90.6 × 120	90.6 × 120	71.1 × 94.2	
	KCX-M6541-20 (2,000,000 pixels)	143.2 × 188.1	136 × 178.7	136 × 178.7	106.7 × 140.1	
0.5	Angle-of-view size X × Y [mm]	WD [mm]	69.5	118.6	143	296.8
		KCX-M6541-00 (300,000 pixels)	36.6 × 48	59 × 77.4	45.7 × 60	91.4 × 119.9
	KCX-M6541-10 (1,300,000 pixels)	36.3 × 48	58.5 × 77.5	45.3 × 60	90.6 × 120	
	KCX-M6541-20 (2,000,000 pixels)	54.4 × 71.5	87.8 × 115.3	68 × 89.4	136 × 178.7	
1.0	Angle-of-view size X × Y [mm]	WD [mm]	0.100	0.062	0.080	0.040
		KCX-M6541-00 (300,000 pixels)	22.6 × 29.6	29.5 × 38.7	30.5 × 40	45.7 × 60
	KCX-M6541-10 (1,300,000 pixels)	22.4 × 29.7	29.3 × 38.8	30.2 × 40	45.3 × 60	
	KCX-M6541-20 (2,000,000 pixels)	33.6 × 44.2	43.9 × 57.7	45.4 × 59.6	68 × 89.4	
1.5	Angle-of-view size X × Y [mm]	WD [mm]	0.162	0.124	0.120	0.080
		KCX-M6541-00 (300,000 pixels)	22.6 × 29.6	29.5 × 38.7	30.5 × 40	45.7 × 60
	KCX-M6541-10 (1,300,000 pixels)	22.4 × 29.7	29.3 × 38.8	30.2 × 40	45.3 × 60	
	KCX-M6541-20 (2,000,000 pixels)	33.6 × 44.2	43.9 × 57.7	45.4 × 59.6	68 × 89.4	
2.0	Angle-of-view size X × Y [mm]	WD [mm]			65.4	90.8
		KCX-M6541-00 (300,000 pixels)	18.2 × 23.9	22.8 × 29.8	22.8 × 29.8	30 × 39.7
	KCX-M6541-10 (1,300,000 pixels)	18.1 × 23.9	22.5 × 29.9	22.4 × 29.7	29.7 × 39.4	
	KCX-M6541-20 (2,000,000 pixels)	27.1 × 35.6	33.8 × 44.4	33.6 × 44.2	44.6 × 58.6	
5.0	Angle-of-view size X × Y [mm]	WD [mm]			91.2	123.6
		KCX-M6541-00 (300,000 pixels)	14.7 × 19.2	18.4 × 24.1	18.4 × 24.1	27.9 × 37
	KCX-M6541-10 (1,300,000 pixels)	14.5 × 19.2	18.3 × 24.2	18.3 × 24.2	27.8 × 36.9	
	KCX-M6541-20 (2,000,000 pixels)	21.8 × 28.6	27.4 × 36	27.4 × 36	41.9 × 55	

Note. WD is the lens tip reference.

Close-up ring [mm]			Lens			
			8 mm lens for megapixel KCX-M7214-40	12 mm lens for megapixel KCX-M7214-50	16 mm lens for megapixel KCX-M7214-60	25 mm lens for megapixel KCX-M7214-70
None	Angle-of-view size X × Y [mm]	WD [mm]	100	100	100	150
		KCX-M6541-00 (300,000 pixels)	52.3 × 68.5	36.6 × 48	26.9 × 35.3	24.6 × 32.2
	KCX-M6541-10 (1,300,000 pixels)	51.8 × 68.6	36.3 × 48	26.7 × 35.3	24.4 × 32.3	
	KCX-M6541-20 (2,000,000 pixels)	77.7 × 102.1	54.4 × 71.5	40 × 52.6	36.5 × 48	
0.5	Angle-of-view size X × Y [mm]	WD [mm]	46	113.6	66.1	283.2
		KCX-M6541-00 (300,000 pixels)	27.7 × 36.4	58.1 × 76.2	25.4 × 33.3	89.2 × 117
	KCX-M6541-10 (1,300,000 pixels)	27.5 × 36.4	57.5 × 76.2	25.2 × 33.4	88.4 × 117.1	
	KCX-M6541-20 (2,000,000 pixels)	41.2 × 54.2	86.4 × 113.5	37.8 × 49.7	132.7 × 174.3	
1.0	Angle-of-view size X × Y [mm]	WD [mm]	0.132	0.063	0.144	0.041
		KCX-M6541-00 (300,000 pixels)	19.8 × 26	45.2 × 59.2	18.6 × 24.4	59 × 77.4
	KCX-M6541-10 (1,300,000 pixels)	19.6 × 26	44.8 × 59.3	18.4 × 24.4	58.5 × 77.5	
	KCX-M6541-20 (2,000,000 pixels)	29.4 × 38.7	67.2 × 88.3	27.7 × 36.3	87.8 × 115.3	
1.5	Angle-of-view size X × Y [mm]	WD [mm]	0.185	0.081	0.197	0.062
		KCX-M6541-00 (300,000 pixels)	16.3 × 21.4	32.7 × 42.9	16.1 × 21.1	39.4 × 51.6
	KCX-M6541-10 (1,300,000 pixels)	16.1 × 21.4	32.4 × 42.9	15.9 × 21.1	39 × 51.7	
	KCX-M6541-20 (2,000,000 pixels)	24.2 × 31.8	48.6 × 63.8	23.9 × 31.4	58.5 × 76.9	
2.0	Angle-of-view size X × Y [mm]	WD [mm]	0.225	0.112	0.228	0.093
		KCX-M6541-00 (300,000 pixels)	13.8 × 18.1	22.5 × 29.5	14.2 × 18.6	29.8 × 39
	KCX-M6541-10 (1,300,000 pixels)	13.7 × 18.1	22.3 × 29.5	14 × 18.6	29.5 × 39.1	
	KCX-M6541-20 (2,000,000 pixels)	20.5 × 26.9	33.4 × 43.9	21 × 27.6	44.3 × 58.1	
5.0	Angle-of-view size X × Y [mm]	WD [mm]	0.266	0.163	0.259	0.123
		KCX-M6541-00 (300,000 pixels)	10.5 × 13.8	18.3 × 24	10.4 × 13.8	18.2 × 24
	KCX-M6541-10 (1,300,000 pixels)	10.4 × 13.8	18.2 × 24	10.4 × 13.8	18.2 × 24	
	KCX-M6541-20 (2,000,000 pixels)	15.6 × 20.5	27.2 × 35.8	15.6 × 20.5	27.2 × 35.8	

Note. The above table shows the field of view when the standard lens and close-up ring are used. (Closest distance value is shown in No Close-up Ring column).

Note. If a close-up ring is not used, a WD less than the value shown in this table cannot be used.

Note. If a close-up ring is used, only WD in the region of this value can be used.

Note. Values in this table are for reference only; Actual values may vary.

iVY2 System

Accessories and part options

iVY2 System

Standard accessories

● iVY2 unit

The iVY2 unit adds robot vision to the RCX340 robot controller.



Model	No lighting	KCX-M4400-V0
	With lighting	KCX-M4400-L0

● iVY2 unit accessories

Name	Individual model
Camera trigger input cable connector	KX0-M657K-00
24V power supply connector	KCF-M5382-00

● Support software for PC iVY2 Studio

iVY2 Studio is support software for the iVY2 system that allows registering part types and reference marks as well as monitoring the work search status during automatic robot operation by connecting to the robot controller.



● Environment

Software model	KCX-M4988-00
OS	Microsoft Windows XP / Vista (32bit/64bit) / 7 (32bit/64bit) / 8, 8.1 (32bit/64bit)
CPU	Processor that meets or exceeds the suggested requirements for the OS being used.
Memory	Suggested amount of memory or more for the OS being used.
Hard disk capacity	16MB of available space required on installation drive.
Display	800 x 600 dot, or higher, 32768 colors (16bit High Color) or higher (recommended)
Communication Port	Ethernet Port of TCP/IP

Note. Microsoft, Windows XP, Windows Vista, Windows 7, Windows 8, 8.1 are registered trademarks of the Microsoft Corporation, USA.

Options

APPLICATION

Articulated robots
YA

Compact
single-axis robots
TRANSEURO

Single-axis robots
FLIP-X

Linear motor
single-axis robots
PHASER

Cartesian
robots
XX-X

SCARA
robots
YK-X

Pick & place
robots
YP-X

CLEAN

CONTROLLER

INFORMATION

Robot
positioner

Pulse string
driver

Robot
controller

iVY2

Option

● Camera



CCD camera	300,000 pixel	648×494 (VGA)	KCX-M6541-00
	1,300,000 pixel	1280×966 (SXGA)	KCX-M6541-10
	2,000,000 pixel	1624×1236 (UXGA)	KCX-M6541-20
CMOS camera	5,000,000 pixel	2592×1944 (QSXGA)	KCX-M6541-30

● Lens



Model	8mm	KCX-M7214-00
	12mm	KCX-M7214-10
	16mm	KCX-M7214-20
	25mm	KCX-M7214-30
	8mm (megapixel support)	KCX-M7214-40
	12mm (megapixel support)	KCX-M7214-50
	16mm (megapixel support)	KCX-M7214-60
	25mm (megapixel support)	KCX-M7214-70

● Close-up ring



Model	0.5mm	KX0-M7215-00
	1.0mm	KX0-M7215-10
	2.0mm	KX0-M7215-20
	5.0mm	KX0-M7215-30

● Lighting control board

This board adds lighting control functionality to the iVY2 system. (Installed in the iVY2 unit when shipped)

Model	KCX-M4403-L0
-------	--------------

● Lighting control board accessories

Name	Model
Lighting power cable connector	KX0-M657K-10

● Tracking board

This board adds conveyor tracking functionality to the RCX340 controller.

Model	KCX-M4400-T0
-------	--------------

● Tracking board accessories

Name	Single unit model
AB phase input cable connector	KX0-M657K-20

● Recommended option cable ^{Note}

Name	Single unit model
AB phase input cable (10 m, only for counter 1)	KX0-M66AF-00

Note. Not included.
 We can provide an option that is pre-wired to the AB phase input cable connector.

● Camera cable

Cable for connecting the camera to the iVY2 board.

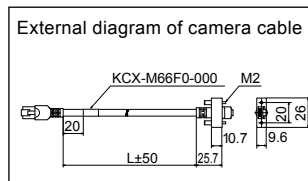

Model	5m	KCX-M66F0-00
	10m	KCX-M66F0-10
	15m	KCX-M66F0-20

● LAN cable with shield cloth (5 m)



Model	KX0-M55G0-00
-------	--------------