



Efficiency In Production



YAMAHA SCARA ROBOTS LOW COST HIGH PERFORMANCE MODEL

# YK-XE series

High performance × Durability × Economy

Maximum payload  
**10kg**

**Heavy workpieces are also supported.**

Suitable for transfer or assembly process of automotive part



Clean type  
"YK-XEC" series  
is also  
available!



**Robotics Operations**  
**Sales & Marketing Section**  
**FA Sales & Marketing Division**  
127 Toyooka, Chuo-Ku, Hamamatsu, Shizuoka 433-8103, Japan  
Tel. +81-53-525-8350 Fax. +81-53-525-8378  
URL <https://global.yamaha-motor.com/business/robot/>

 **Safety Precautions**

Read the instruction manual thoroughly to operate the robot in a correct manner.

●Specifications and appearance are subject to change without prior notice.

Efficiency and reliability in production at affordable price

## Low cost high performance models that achieve both the high operation performance and affordable price

Providing Efficiency and Quality in production with Affordable price.

### Optimal for transfer and assembly of automotive parts

Maximum payload **10kg\***

\*YK510XE-10, YK610XE-10, YK710XE-10



Model	Arm length	Maximum payload	Standard cycle time	R-axis tolerable moment of inertia
YK400XE-4	400mm	4kg	0.41sec	0.05kgm <sup>2</sup>
YK510XE-10	510mm	10kg	0.38sec	0.3kgm <sup>2</sup>
YK610XE-10	610mm	10kg	0.39sec	0.3kgm <sup>2</sup>
YK710XE-10	710mm	10kg	0.42sec	0.3kgm <sup>2</sup>

### Affordable Price and Improved Performance

Both the high operation performance and affordable price are achieved. Production equipment with high cost performance can be constructed.



### Application Examples

#### Palletizing



#### Loading and unloading

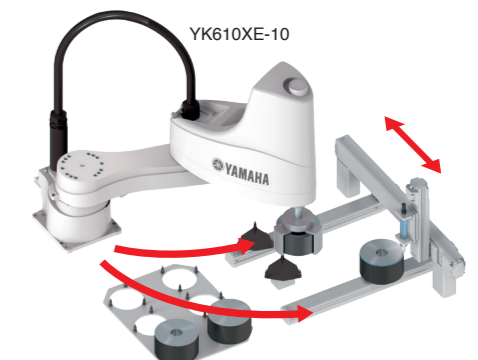

#### Assembly (or Pick & Place)

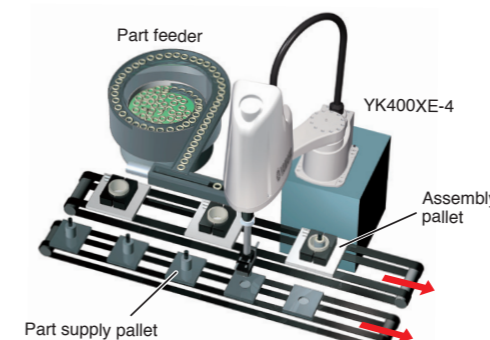

#### Inspection



### Improvement of productivity by high-speed operation

By reviewing the arm structure, the vibration is reduced and the motion is optimized to shorten the standard cycle time.

High-speed, less-vibration, and agile operation contributes to improvement of the productivity.

Standard cycle time **0.39sec\***

\* For YK610XE-10

YK610XE-10

0.39sec

Previous YAMAHA model  
YK600XGL

0.63sec

Standard Cycle time

Reduced by approx. **40%**

### For a wide variety of applications Maximum payload 4kg to 10kg

Assembly Packaging Palletizing Sorting Inspection Labelling Soldering

The models support a wide variety of fields such as assembly work that requires a high precision or food sorting work that requires a high-speed operation. As the maximum payload is 10 kg, heavy workpieces such as automotive parts can also be supported.

## Improved User Interface

Enhanced size and numbers of air tubes and user I/O for end effectors. Tubes and wires are positioned for easy layout and reduced risk of disconnection. (YK610XE-10 and YK710XE-10)

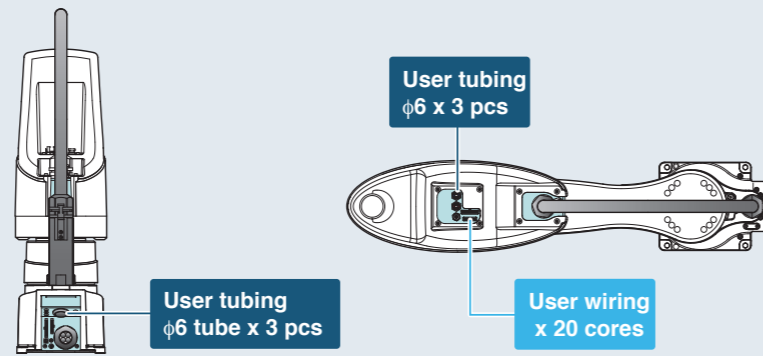

\* YK400XE-4 provides the user wiring x 10 cores and the User tubing φ4 x 3 pcs.

## In Yamaha YK-XE series Acceleration/Deceleration is optimized automatically

The optimal acceleration and deceleration are automatically selected from the arm posture at the time of operation start and the arm posture at the time of operation end. The motor peak torque or the tolerable peak torque of the speed reducer is not exceeded by inputting only three parameters\*. The full power of the motor is always output to maintain the high acceleration/deceleration.

\* Payload, R-axis moment of inertia, and offset amount of R-axis moment of inertia

Inertia of extended arm can be as high as 5 times of that of folded arm

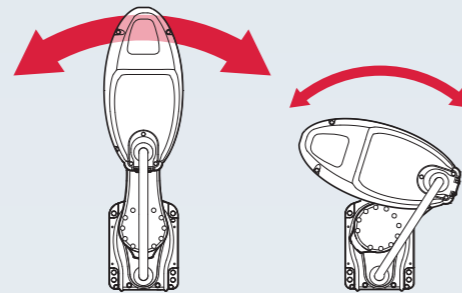

This optimization feature helps:

- Extends service/maintenance period
- Minimizes vibration during operation
- Controllability in motion
- Keeps peak torque within a tolerance to prevent premature failure

## Through-shaft and through-cap have been added.

Option specifications **NEW** Also compatible with YK400XE-4

“Through-shaft” or “through-cap” option for wiring and tubing that is convenient to run the air tubing and wiring can be selected. The wiring and tubing routes can be investigated easily without designing and manufacturing a stay for installing the wiring and tubing. In addition, by passing the wiring and tubing through the inside of the main body, worries about wire breakage or disconnection are reduced during operation. (Only through-shaft is available in YK400XE-4.)



## Brake release switch is selectable.

Option specifications

In the emergency stop state, the Z-axis brake is released and the Z-axis can be moved up or down while the brake release switch is held down. Releasing the switch applies the brake to the Z-axis. This improves the convenience during installation adjustment.

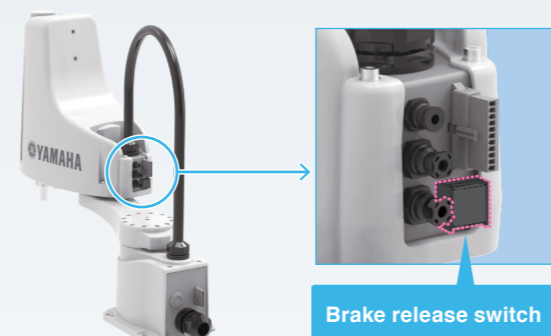

## Easier operation in combination with the RCX340 controller

RCX340 comprehensive controller brings out maximum potential of YK400XE robot system. Optional integrated vision system “RCXiVY2+” provides simplified image processing. Choice of PC Programming Software or Teaching Pendant available.



## Simple and Easy integration of Vision System

Robot controller with vision and gripper interface

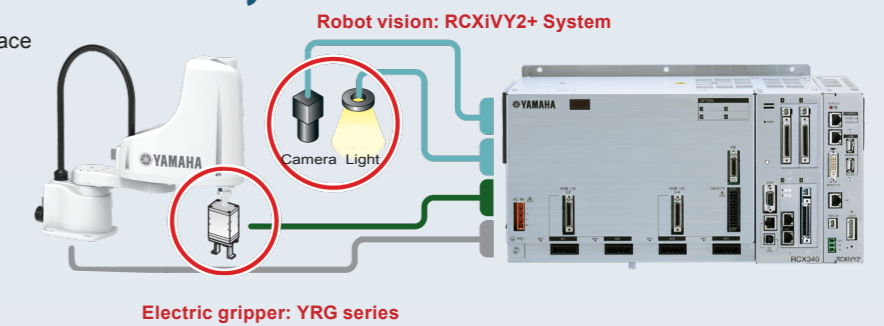

## Compatible with various field networks

The robot is compatible with full field networks such as CC-Link, EtherNet/IP™, DeviceNet™, PROFIBUS, PROFINET, and EtherCAT.



## Reliability backed by 45-year experience of SCARA robot development

Originally developed in-house to provide durable and accurate motion control in harsh environment of motorcycle manufacturing, Yamaha SCARA robot has been “road tested” and proven over 45 years in various fields.

\* The product release was 1984.



## YK-XEC series

### Clean type is also available in the product lineup.

While maintaining the cost performance of the YK-XE, the YK-XEC series provides the reliable cleanliness of ISO CLASS 4\*. The YK-XEC series is ideal for precision instruments and the food, pharmaceutical, and cosmetics industries.

Four variations of arm lengths available



Model	Arm length(mm)	Maximum payload(kg)	Standard cycle time (sec) <sup>*1</sup>
YK400XEC-4	400	4	0.45
YK510XEC-10	510	10	0.42
YK610XEC-10	610		0.44
YK710XEC-10	710		0.49

\*1 Operating conditions: Horizontal 300 mm, vertical 25 mm reciprocation, coarse positioning arch motion, payload capacity 2 kg

YK-XEC with controller



# YK400XE-4

Standard type: Small type

LOW COST HIGH PERFORMANCE MODEL



● Arm length 400mm ● Maximum payload 4kg

## Ordering method

Model	Maximum payload	Return-to-origin method	Z-axis stroke	Hollow shaft	Brake release switch	Cable	Controller / Number of controllable axes	Safety standard	Option A to E (OP.A to E)	Absolute battery
YK400XE-4	150	S: Sensor T: Stroke end		No entry: None S: With hollow shaft C: With hollow cap	No entry: None BS: With brake release switch	3L: 3.5m 5L: 5m 10L: 10m	RCX340-4			

Specify various controller setting items.  
\* For details about controller, refer to the RCX340 catalog or view YAMAHA's website.

## Specifications

Axis specifications	Arm length	X-axis	Y-axis	Z-axis	R-axis
	Rotation angle	225 mm	175 mm	150 mm	-
		+/-132°	+/-150°	-	+/-360°
AC servo motor output		200 W	100 W	100 W	100 W
Deceleration mechanism	Transmission method	Direct-coupled		Timing belt	
	Motor to speed reducer				
Speed reducer to output	Direct-coupled		Timing belt		
	Repeatability <sup>Note 1</sup>				
		+/-0.01 mm	+/-0.01 mm	+/-0.01°	
Maximum speed		6 m/sec		1.1 m/sec	2600 °/sec
Maximum payload		4 kg (Standard specification, Option specifications <sup>Note 4</sup> ), 3 kg (Option specifications <sup>Note 5</sup> )			
Standard cycle time: with 2kg payload <sup>Note 2</sup>		0.41 sec			
R-axis tolerable moment of inertia <sup>Note 3</sup>		0.05 kgm <sup>2</sup>			
User wiring		0.2 sq × 10 wires			
User tubing (Outer diameter)		φ 4 × 3			
Travel limit		1.Soft limit 2.Mechanical stopper (X,Y,Z axis)			
Robot cable length		Standard: 3.5 m Option: 5 m, 10 m			
Weight		17 kg			

Note 1. This is the value at a constant ambient temperature. (X,Y axes)  
Note 2. When reciprocating 300mm in horizontal and 25mm in vertical directions and performing the coarse positioning arch operation.  
Note 3. The acceleration coefficient is set automatically in accordance with the tip weight and offset amount for R-axis moment of inertia settings.  
Note 4. Maximum payload of the standard or option specifications (brake release switch type) is 4 kg.  
Note 5. Maximum payload of the option specifications (user wiring/tubing through shaft type) is 3 kg.

## Controller

Controller	Power capacity (VA)	Operation method
RCX340	1000	Programming / I/O point trace / Remote command / Operation using RS-232C communication

Note. The movement range can be restricted by adding the X- and Y-axis mechanical stoppers. (The maximum movement range was set at shipment.)  
See our robot manuals (installation manuals) for detailed information.

Note. To set the standard coordinates with high accuracy, use a standard coordinate setting jig (option). Refer to the user's manual (installation manual) for more details.

Our robot manuals (installation manuals) can be downloaded from our website at the address below:  
<https://global.yamaha-motor.com/business/robot/>

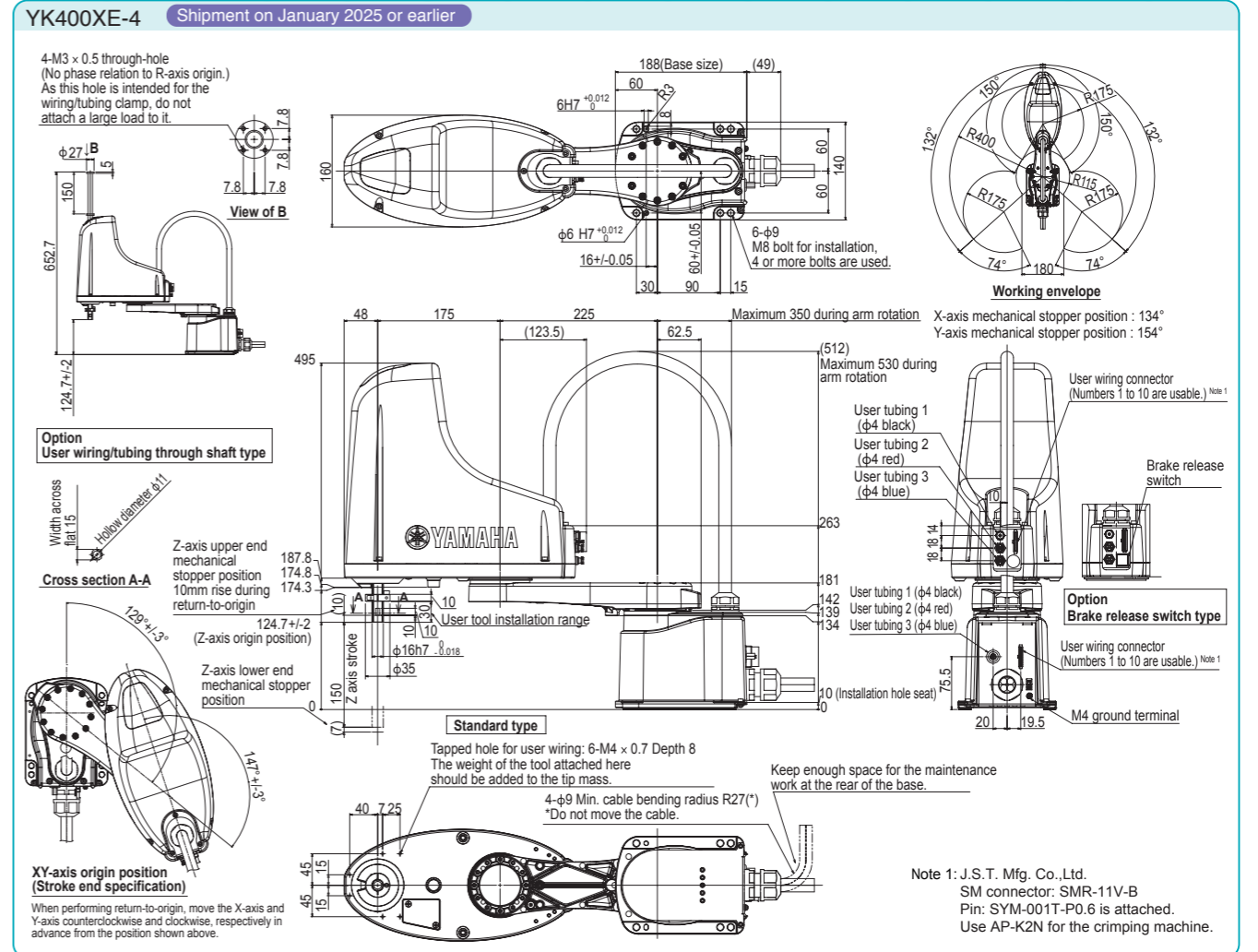
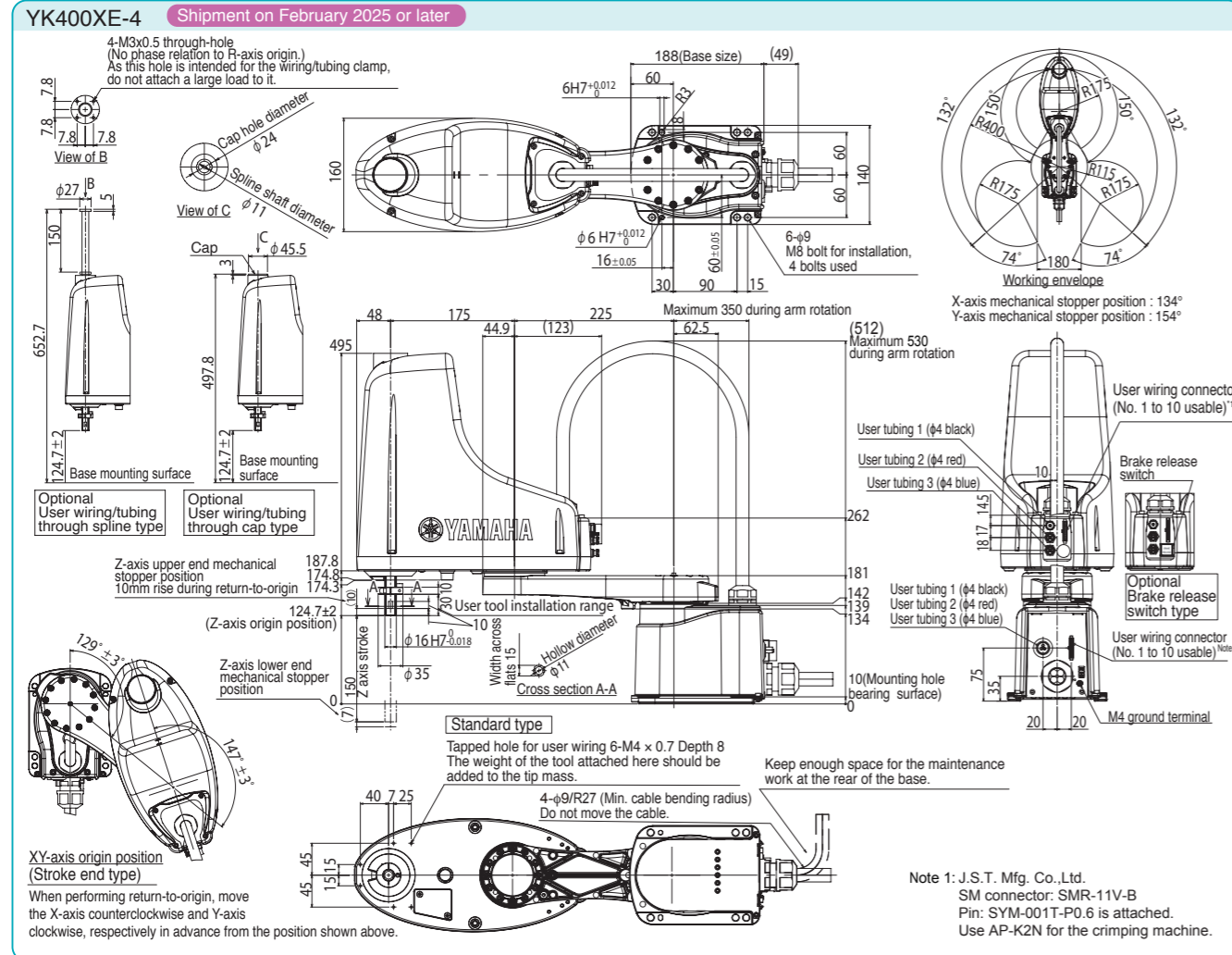

# YK510XE-10

Standard type: Medium type

● LOW COST HIGH PERFORMANCE MODEL

- Arm length 510mm
- Maximum payload 10kg

## Ordering method

YK510XE-10-200		RCX340-4								
Model	Maximum payload	Z axis stroke	Tool flange	Hollow shaft/cap <sup>Note 1</sup>	Brake release switch	Cable	Controller / Number of controllable axes	Safety standard	Option A to E (OP.A to E)	Absolute battery
		No entry: None F: With tool flange	No entry: None F: With tool flange C: With hollow cap	No entry: None S: With hollow shaft C: With hollow cap	No entry: None BS: With brake release switch	3L: 3.5m 5L: 5m 10L: 10m				

Specify various controller setting items.  
\* For details about controller, refer to the RCX340 catalog or view YAMAHA's website.

Note. The return-to-origin method is provided only in the sensor specifications, but not in the stroke end specifications.

## Specifications

Axis specifications	Arm length	X-axis	Y-axis	Z-axis	R-axis
	Rotation angle	235 mm	275 mm	200 mm	-
		+/-134°	+/-152°	-	+/-360°
AC servo motor output		400 W	200 W	200 W	200 W
Deceleration mechanism	Transmission method	Direct-coupled		Timing belt	
	Motor to speed reducer	Direct-coupled		Timing belt	
	Speed reducer to output	Direct-coupled		Timing belt	
Repeatability <sup>Note 1</sup>		+/-0.01 mm		+/-0.01 mm	+/-0.01°
Maximum speed		7.8 m/sec		2 m/sec	2600 °/sec
Maximum payload		10 kg (Standard specification, Option specifications <sup>Note 4</sup> ), 9 kg (Option specifications <sup>Note 5</sup> )			
Standard cycle time: with 2kg payload <sup>Note 2</sup>		0.38 sec			
R-axis tolerable moment of inertia <sup>Note 3</sup>		0.3 kgm <sup>2</sup>			
User wiring		0.2 sq x 20 wires			
User tubing (Outer diameter)		φ 6 x 3			
Travel limit		1.Soft limit 2.Mechanical stopper (X,Y,Z axis)			
Robot cable length		Standard: 3.5 m Option: 5 m, 10 m			
Weight		25 kg			

Note 1. This is the value at a constant ambient temperature. (X,Y axes)  
Note 2. When reciprocating 300mm in horizontal and 25mm in vertical directions and performing the coarse positioning arch operation.  
Note 3. The acceleration coefficient is set automatically in accordance with the tip weight and offset amount for R-axis moment of inertia settings.  
Note 4. Maximum payload of the standard or option specifications (brake release switch type, user wiring/tubing through cap type) is 10 kg.  
Note 5. Maximum payload of the option specifications (tool flange mount type, user wiring/tubing through shaft type) is 9 kg.

## Controller

Controller	Power capacity (VA)	Operation method
RCX340	1700	Programming / I/O point trace / Remote command / Operation using RS-232C communication

Note. The movement range can be restricted by adding the X- and Y-axis mechanical stoppers. (The maximum movement range was set at shipment.)  
See our robot manuals (installation manuals) for detailed information.

Note. To set the standard coordinates with high accuracy, use a standard coordinate setting jig (option). Refer to the user's manual (installation manual) for more details.

Our robot manuals (installation manuals) can be downloaded from our website at the address below:  
<https://global.yamaha-motor.com/business/robot/>

## YK510XE-10

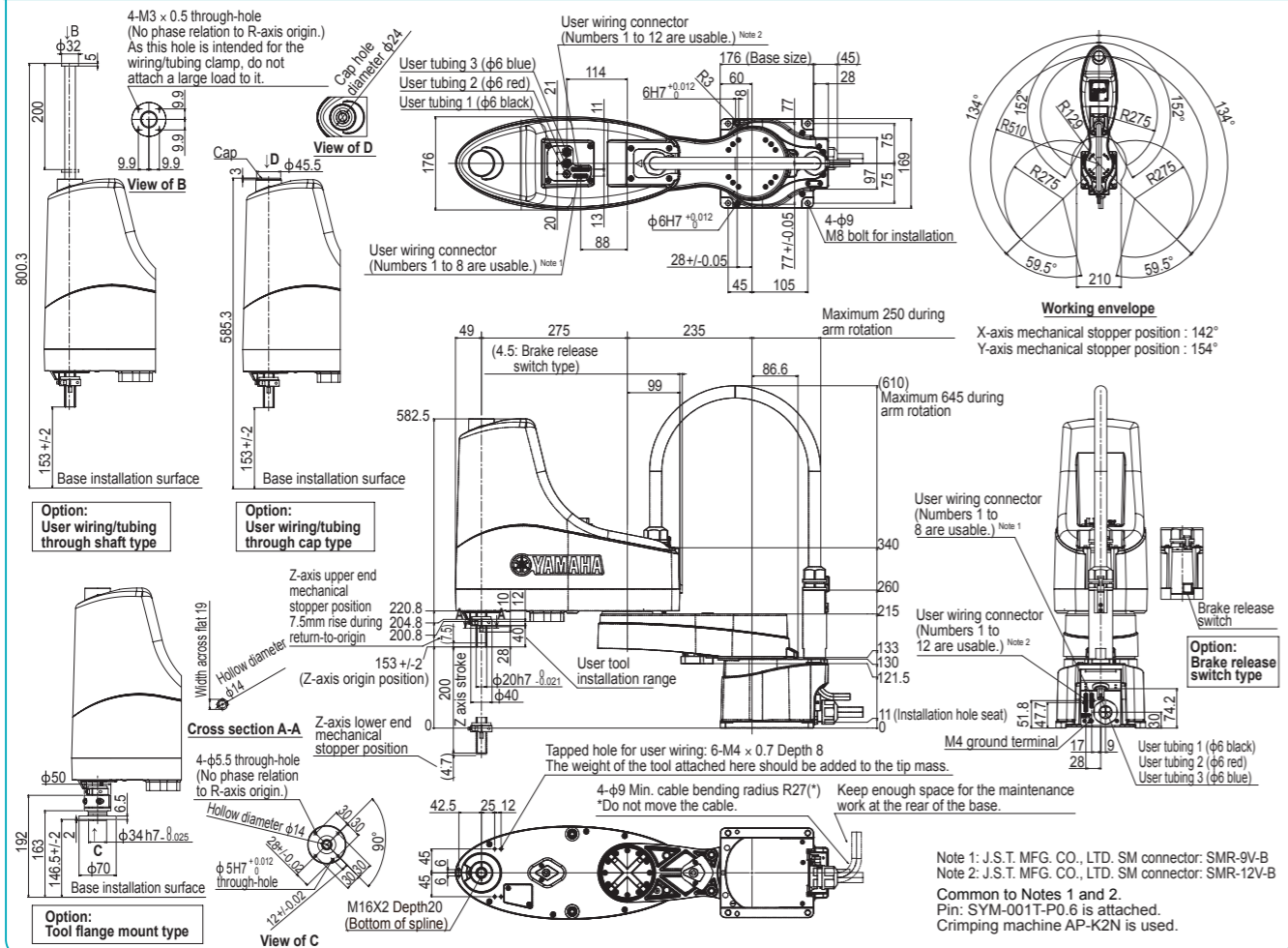

# YK610XE-10

Standard type: Medium type

● LOW COST HIGH PERFORMANCE MODEL

- Arm length 610mm
- Maximum payload 10kg

## Ordering method

YK610XE-10-200		RCX340-4								
Model	Maximum payload	Z axis stroke	Tool flange	Hollow shaft/cap <sup>Note 1</sup>	Brake release switch	Cable	Controller / Number of controllable axes	Safety standard	Option A to E (OP.A to E)	Absolute battery
		No entry: None F: With tool flange	No entry: None S: With hollow shaft C: With hollow cap	No entry: None S: With hollow shaft C: With hollow cap	No entry: None BS: With brake release switch	3L: 3.5m 5L: 5m 10L: 10m				

Specify various controller setting items.  
\* For details about controller, refer to the RCX340 catalog or view YAMAHA's website.

Note. The return-to-origin method is provided only in the sensor specifications, but not in the stroke end specifications.

## Specifications

Axis specifications	Arm length	X-axis	Y-axis	Z-axis	R-axis
	Rotation angle	335 mm	275 mm	200 mm	-
		+/-134°	+/-152°	-	+/-360°
AC servo motor output		400 W	200 W	200 W	200 W
Deceleration mechanism	Transmission method	Direct-coupled		Timing belt	
	Motor to speed reducer	Direct-coupled		Timing belt	
	Speed reducer to output	Direct-coupled		Timing belt	
Repeatability <sup>Note 1</sup>		+/-0.01 mm		+/-0.01 mm	+/-0.01°
Maximum speed		8.6 m/sec		2 m/sec	2600 °/sec
Maximum payload		10 kg (Standard specification, Option specifications <sup>Note 4</sup> ), 9 kg (Option specifications <sup>Note 5</sup> )			
Standard cycle time: with 2kg payload <sup>Note 2</sup>		0.39 sec			
R-axis tolerable moment of inertia <sup>Note 3</sup>		0.3 kgm <sup>2</sup>			
User wiring		0.2 sq x 20 wires			
User tubing (Outer diameter)		φ 6 x 3			
Travel limit		1.Soft limit 2.Mechanical stopper (X,Y,Z axis)			
Robot cable length		Standard: 3.5 m Option: 5 m, 10 m			
Weight		25 kg			

Note 1. This is the value at a constant ambient temperature. (X,Y axes)  
Note 2. When reciprocating 300mm in horizontal and 25mm in vertical directions and performing the coarse positioning arch operation.  
Note 3. The acceleration coefficient is set automatically in accordance with the tip weight and offset amount for R-axis moment of inertia settings.  
Note 4. Maximum payload of the standard or option specifications (brake release switch type, user wiring/tubing through cap type) is 10 kg.  
Note 5. Maximum payload of the option specifications (tool flange mount type, user wiring/tubing through shaft type) is 9 kg.

## Controller

Controller	Power capacity (VA)	Operation method
RCX340	1700	Programming / I/O point trace / Remote command / Operation using RS-232C communication

Note. The movement range can be restricted by adding the X- and Y-axis mechanical stoppers. (The maximum movement range was set at shipment.)  
See our robot manuals (installation manuals) for detailed information.

Note. To set the standard coordinates with high accuracy, use a standard coordinate setting jig (option). Refer to the user's manual (installation manual) for more details.

Our robot manuals (installation manuals) can be downloaded from our website at the address below:  
<https://global.yamaha-motor.com/business/robot/>

## YK610XE-10

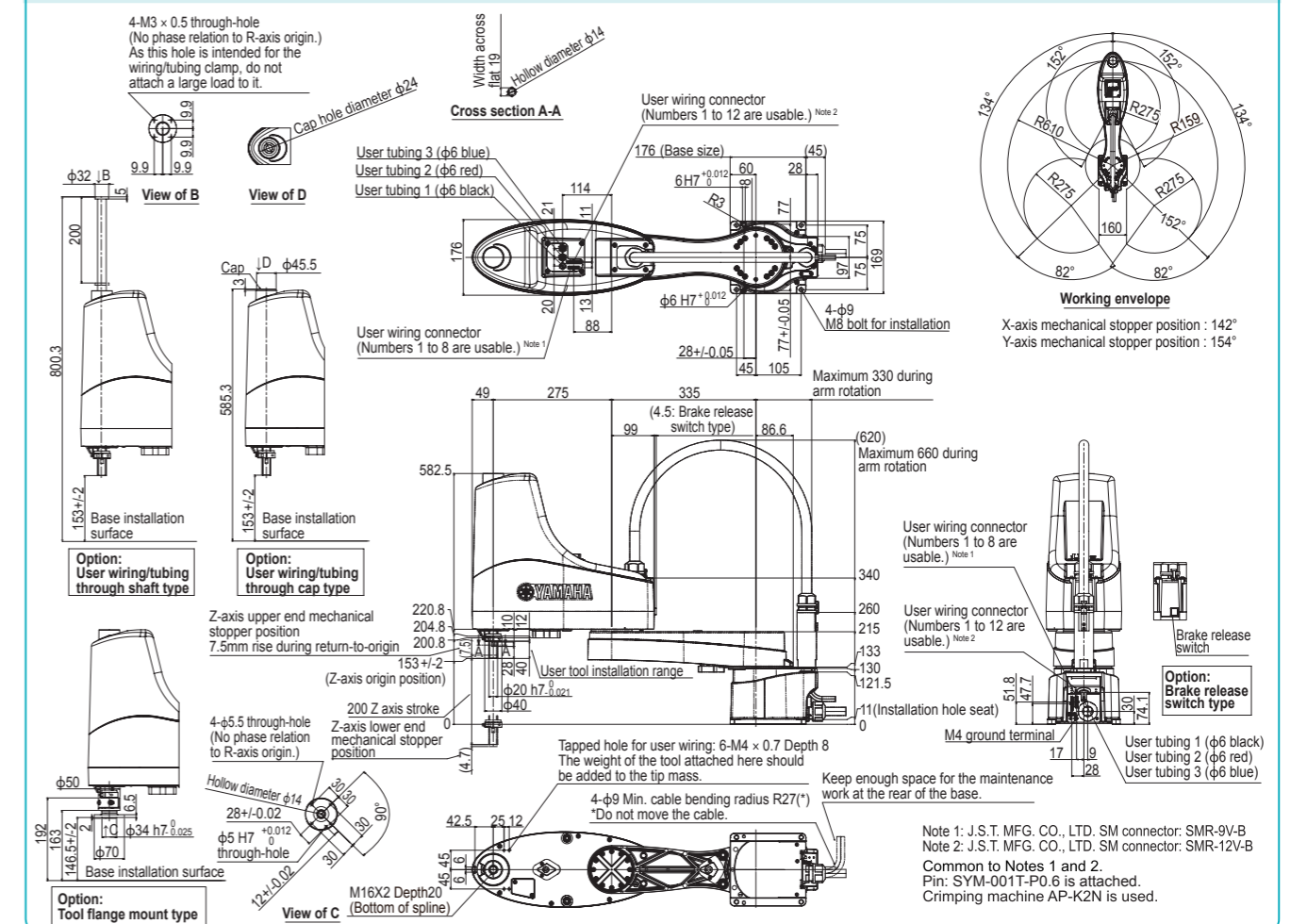

# YK710XE-10

Standard type: Large type

LOW COST HIGH PERFORMANCE MODEL



Arm length 710mm Maximum payload 10kg

## Ordering method

YK710XE-10-200		RCX340-4								
Model	Maximum payload	Z axis stroke	Tool flange	Hollow shaft/cap	Brake release switch	Cable	Controller / Number of controllable axes	Safety standard	Option A to E (OPA to E)	Absolute battery
			No entry: None F: With tool flange	No entry: None S: With hollow shaft C: With hollow cap	No entry: None BS: With brake release switch	3L: 3.5m 5L: 5m 10L: 10m				

Specify various controller setting items.  
\* For details about controller, refer to the RCX340 catalog or view YAMAHA's website.

Note. The return-to-origin method is provided only in the sensor specifications, but not in the stroke end specifications.

## Specifications

Axis specifications	Arm length	X-axis	Y-axis	Z-axis	R-axis
		435 mm	275 mm	200 mm	-
	Rotation angle	+/-134 °	+/-152 °	-	+/-360 °
AC servo motor output		400 W	200 W	200 W	200 W
Deceleration mechanism	Transmission method	Direct-coupled		Timing belt	
	Speed reducer to output	Direct-coupled		Timing belt	
Repeatability	Note 1	+/-0.02 mm		+/-0.01 mm	+/-0.01 °
Maximum speed		9.5 m/sec		2 m/sec	2600 °/sec
Maximum payload		10 kg (Standard specification, Option specifications Note 4), 9 kg (Option specifications Note 5)			
Standard cycle time: with 2kg payload	Note 2	0.42 sec			
R-axis tolerable moment of inertia	Note 3	0.3 kgm <sup>2</sup>			
User wiring		0.2 sq × 20 wires			
User tubing (Outer diameter)		φ 6 × 3			
Travel limit		1.Soft limit 2.Mechanical stopper (X,Y,Z axis)			
Robot cable length		Standard: 3.5 m Option: 5 m, 10 m			
Weight		26 kg			

Note 1. This is the value at a constant ambient temperature. (X,Y axes)  
Note 2. When reciprocating 300mm in horizontal and 25mm in vertical directions and performing the coarse positioning arch operation.  
Note 3. The acceleration coefficient is set automatically in accordance with the tip weight and offset amount for R-axis moment of inertia settings.  
Note 4. Maximum payload of the standard or option specifications (brake release switch type, user wiring/tubing through cap type) is 10 kg.  
Note 5. Maximum payload of the option specifications (tool flange mount type, user wiring/tubing through shaft type) is 9 kg.

## Controller

Controller	Power capacity (VA)	Operation method
RCX340	1700	Programming / I/O point trace / Remote command / Operation using RS-232C communication

Note. The movement range can be limited by changing the positions of X and Y axis mechanical stoppers. (The movement range is set to the maximum at the time of shipment.)  
See our robot manuals (installation manuals) for detailed information.  
Note. To set the standard coordinates with high accuracy, use a standard coordinate setting jig (option). Refer to the user's manual (installation manual) for more details.

Our robot manuals (installation manuals) can be downloaded from our website at the address below:  
<https://global.yamaha-motor.com/business/robot/>

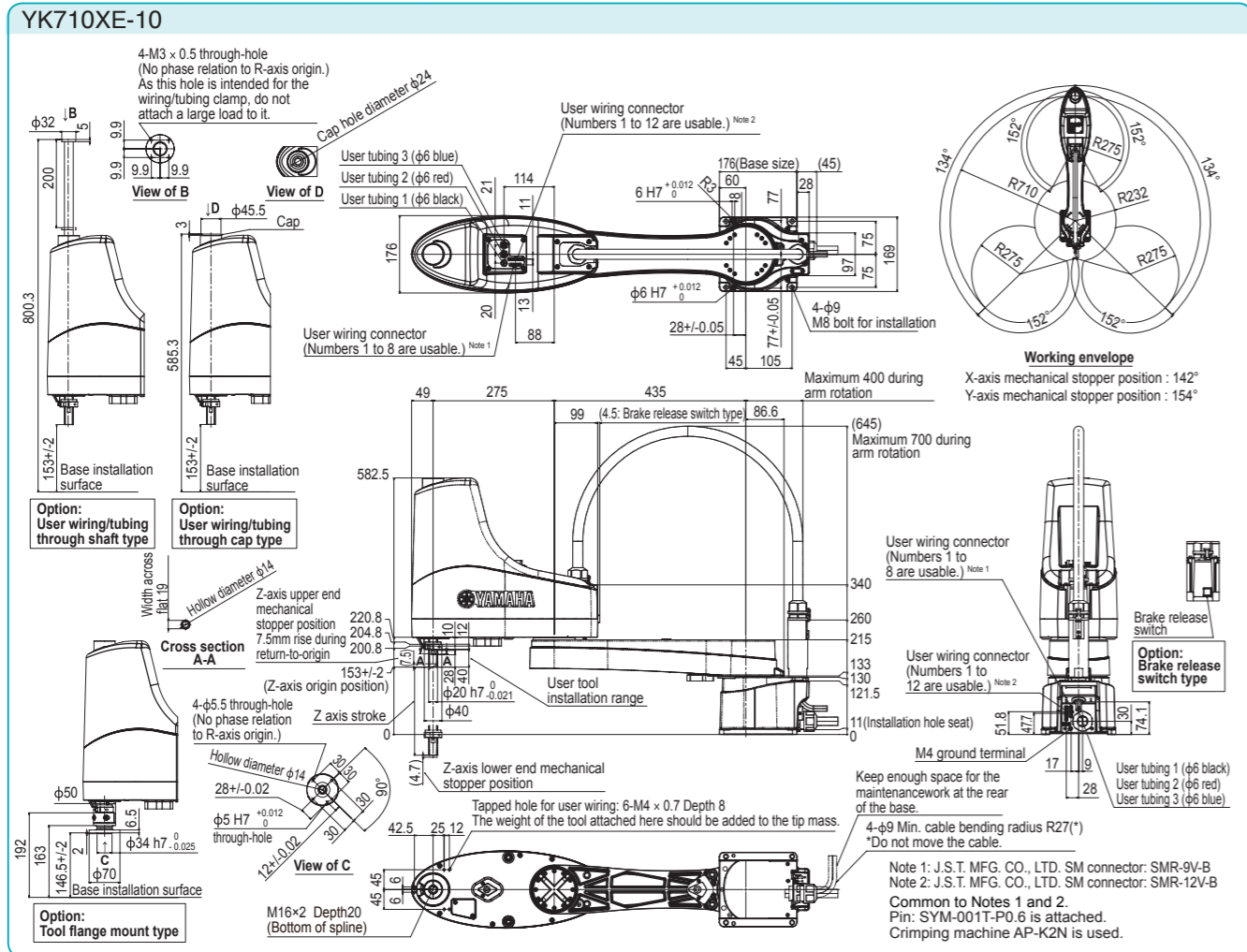

# YAMAHA SCARA ROBOTS LINEUP

Wide variation of models with an arm length ranging from 120 mm to 1200 mm.  
Wall hanging, dust/drip proof, and clean room specifications are also supported.

## Specification sheet

Model/Type	Model	Arm length (mm)	Z-axis stroke (mm)	Maximum payload (kg)	Standard cycle time (sec) Note 1	Beltless structure Note 4
Standard	Orbit type					
	YK350TW	350	130	5.0	0.32	-
	YK500TW	500	130	5.0 (4.0) Note 3	0.29	-
	YK120XG	120	50	1.0	0.33	○
	YK150XG	150	50	1.0	0.33	○
	YK180XG	180	50	1.0	0.33	○
	YK180X	180	100	1.0	0.39	○
	YK220X	220	100	1.0	0.42	○
	YK250XG	250	150	5.0 (4.0) Note 3	0.43	○
	YK350XG	350	150	5.0 (4.0) Note 3	0.44	○
	YK400XE-4	400	150	4.0 (3.0) Note 3	0.41	-
	YK400XG	400	150	5.0 (4.0) Note 3	0.45	○
	YK500XGL	500	150	5.0 (4.0) Note 3	0.48	○
	YK500XG	500	200/300	10.0	0.42	○
	YK510XE-10	510	200	10.0 (9.0) Note 3	0.38	-
	YK600XGL	600	150	5.0 (4.0) Note 3	0.54	○
	YK600XG	600	200/300	10.0	0.43	○
	YK610XE-10	610	200	10.0 (9.0) Note 3	0.39	-
	YK600XGH	600	200/400	20.0 (19.0) Note 3	0.47	○
	YK700XGL	700	200/300	10.0 (9.0) Note 3	0.50	○
YK710XE-10	710	200	10.0 (9.0) Note 3	0.42	-	
YK700XG	700	200/400	20.0 (19.0) Note 3	0.42	○	
YK800XG	800	200/400	20.0 (19.0) Note 3	0.48	○	
YK900XG	900	200/400	20.0 (19.0) Note 3	0.49	○	
YK1000XG	1000	200/400	20.0 (19.0) Note 3	0.49	○	
YK1200X	1200	400	50.0	0.91	-	
YK1200XG	1200	400	50.0	0.61	○	
Wall mount & Inverse model	YK300XGS	300	150	5.0 (4.0) Note 3	0.49	○
	YK400XGS	400	150	5.0 (4.0) Note 3	0.49	○
	YK500XGS	500	200/300	10.0	0.45	○
	YK600XGS	600	200/300	10.0	0.46	○
	YK700XGS	700	200/400	20.0	0.42	○
	YK800XGS	800	200/400	20.0	0.48	○
	YK900XGS	900	200/400	20.0	0.49	○
	YK1000XGS	1000	200/400	20.0	0.49	○
	YK250XGP	250	150	4.0	0.50	○
	YK350XGP	350	150	4.0	0.52	○
	YK400XGP	400	150	4.0	0.50	○
	YK500XGLP	500	150	4.0	0.66	○
	YK500XGP	500	200/300	10.0	0.55	○
	YK600XGLP	600	150	4.0	0.71	○
	YK600XGP	600	200/300	10.0	0.56	○
YK600XGHP	600	200/400	18.0	0.57	○	
YK700XGP	700	200/400	20.0	0.52	○	
YK800XGP	800	200/400	20.0	0.58	○	
YK900XGP	900	200/400	20.0	0.59	○	
YK1000XGP	1000	200/400	20.0	0.59	○	
Dust-proof & Drip-proof model	YK180XC	180	100	1.0	0.42	○
	YK220XC	220	100	1.0	0.45	○
	YK250XGC	250	150	4.0	0.50	○
	YK350XGC	350	150	4.0	0.52	○
	YK400XGC	400	150	4.0	0.50	○
	YK400XEC-4	400	150	4.0	0.45	-
	YK500XC	500	200/300	10.0	0.53	-
	YK500XGLC	500	150	4.0	0.66	○
	YK510XEC-10	510	200	10.0	0.42	-
	YK600XC	600	200/300	10.0	0.56	-
	YK600XGLC	600	150	4.0	0.71	○
	YK610XEC-10	610	200	10.0	0.44	-
	YK700XC	700	200/400	20.0	0.57	-
	YK710XEC-10	710	200	10.0	0.49	-
	YK800XC	800	200/400	20.0	0.57	-
YK1000XC	1000	200/400	20.0	0.60	-	
Clean	Extra small type					
	Small type					
	Medium type					
	Large type					

Note 1. Standard cycle time measurement conditions 25 mm vertical, 300 mm horizontal reciprocating motion (Tiny only 25 mm vertical, 100 mm horizontal reciprocating motion)  
Note 2. The YK300XGS and YK400XGS are custom-order products. For details about the delivery time, please contact YAMAHA.  
Note 3. For the option specifications (tool flange mount type and user wiring/tubing through spline type), the maximum payload becomes the value in ( ).  
Note 4. The beltless construction significantly reduces lost motion, thus maintaining high accuracy for a long period of time. The belt can be used comfortably and maintenance-free for a long period of time without worrying about belt breakage, elongation, or ageing.