

Articulated robots
YA
Linear conveyor modules
LCM100
Motor-less single axis actuator
Robonity
Compact single-axis robots
TRANSEVO
Single-axis robots
FLIP-X
Linear motor single-axis robots
PHASER
Cartesian robots
XY-X

SCARA robots
YK-X

Pick & place robots
YP-X

CLEAN

CONTROLLER

INFORMATION

Arm type

Gantry type

Moving arm type

Pole type

XZ type

CARTESIAN ROBOTS

XY-X

SERIES

CONTENTS

- **Arm & cable variations** 262
- **2-axis spec selection guide** 264
- **3-axis spec selection guide** 266
- **Robot ordering method description** 270
- **Robot ordering method terminology** 271

ARM TYPE

PXYx 2 axes C	272
FXYx 2 axes C	274
FXYx 2 axes / IO C	276
FXYx 3 axes / ZS C	277
FXYx 3 axes / ZT6L C	278
FXYBx 2 axes C	280
FXYBx 2 axes S	282
FXYBx 2 axes / IO C	284
SXYx 2 axes C	286
SXYx 2 axes S	288
SXYx 2 axes / IO C	290
SXYx 3 axes / ZF C	292
SXYx 3 axes / ZF S	293
SXYx 3 axes / ZFL20	294
SXYx 3 axes / ZFH C	295
SXYx 3 axes / ZS C	296
SXYx 3 axes / ZS S	297
SXYx 4 axes / ZRF C	298
SXYx 4 axes / ZRF S	299
SXYx 4 axes / ZRFL20 C	300
SXYx 4 axes / ZRFH C	301
SXYx 4 axes / ZRS C	302
SXYx 4 axes / ZRS S	303
SXYBx 2 axes C	304
SXYBx 3 axes / ZF C	306
SXYBx 3 axes / ZFL20 C	307

SXYBx 3 axes / ZFH C	308
SXYBx 3 axes / ZS C	309
SXYBx 4 axes / ZRS C	310
NXY 2 axes C	312
NXY 3 axes / ZFL C	314
NXY 3 axes / ZFH C	316
NXY-W 4 axes C	318
NXY-W 6 axes / ZFL C	319
NXY-W 6 axes / ZFH C	320
MXYx 2 axes C	322
MXYx 2 axes S	324
MXYx 2 axes / IO C	326
MXYx 3 axes / ZFL20/10 C	327
MXYx 3 axes / ZFH C	328
MXYx 4 axes / ZRFL20/10 C	329
MXYx 4 axes / ZRFH C	330
HXYx 2 axes C	332
HXYx 3 axes / ZL C	334
HXYx 3 axes / ZH C	335
HXYx 4 axes / ZRL C	336
HXYx 4 axes / ZRH C	337
HXYLx 2 axes C	338

GANTRY TYPE

MXYx 2 axes C	340
MXYx 2 axes / IO C	342
MXYx 3 axes / ZFL20/10 C	343
MXYx 3 axes / ZFH C	344
MXYx 4 axes / ZRFL20/10 C	345
MXYx 4 axes / ZRFH C	346
HXYx 2 axes C	348
HXYx 3 axes / ZL C	350
HXYx 3 axes / ZH C	351
HXYx 4 axes / ZRL C	352
HXYx 4 axes / ZRH C	353
HXYLx 2 axes C	354

MOVING ARM TYPE

SXYx 2 axes S	356
SXYx 3 axes / ZF S	358
SXYx 3 axes / ZFL20 S	359
SXYx 3 axes / ZFH S	360
SXYx 3 axes / ZS S	361
MXYx 2 axes C	362
MXYx 3 axes / ZFL20/10 C	364
MXYx 3 axes / ZFH C	365
HXYx 2 axes C	366
HXYx 3 axes / ZH C	368

POLE TYPE

SXYx 2 axes S	370
MXYx 2 axes C	371
MXYx 2 axes S	372
MXYx 3 axes / ZPMH C	373
HXYx 2 axes C	374
HXYx 2 axes S	375
HXYx 3 axes / ZPH C	376
HXYx 3 axes / ZPH S	377

XZ TYPE

SXYx 2 axes / ZF C	378
SXYx 2 axes / ZF S	379
SXYx 2 axes / ZFL20 C	380
SXYx 2 axes / ZS C	381
SXYx 2 axes / ZF C	382
SXYBx 2 axes / ZFL20 C	383
MXYx 2 axes / ZFL10 C	384
MXYx 2 axes / ZFH C	385
HXYx 2 axes / ZL C	386
HXYx 2 axes / ZH C	387

Arm & cable variations

Cable variations

Two cable types are available; cable carrier type and whipover type. (except PXYX) The cable carrier type is supplied with a user cable as standard so that cable can be added easily. The whipover type is supplied with a user cable and tube as standard set. A cable duct specially designed for clean rooms is also available. (See P.480 to P.485 for detailed information on Clean Cartesian robots.)

Cable carrier (C)

When adding cables to a cable carrier track, keep the cable occupation rate at 30% or less.

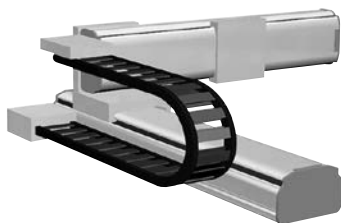

Note. User cable 10 cores, 0.3 sq.

Whipover (S)

Adding a load on whipover will result in sagging and cut. Sagging may also occur when using long strokes.

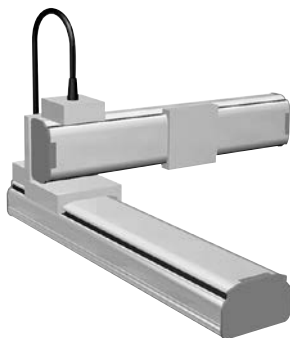

Note. User cable: 7 cores, 0.2 sq.
Note. User tube: 2 φ4 air tubes.

Arm variations

The first step for selection of Cartesian type robot models is to check for applicable models according to specific use and operation area.

Arm type

The type with moving Y-axis carriage.



P.272

Gantry type

The type with a guide railing at the end of Y-axis for support.

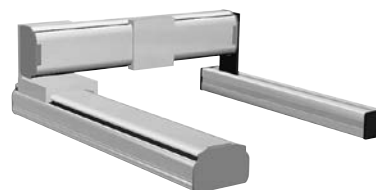

P.340

Moving arm type

The type with a moving Y-axis arm.



P.356

Pole type

The type with vertically moving Y-axis carriage.

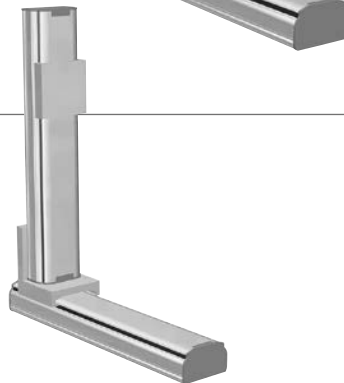

P.370

XZ type

The type with combination of X-axis for horizontal movement and Z-axis for vertical movement.



P.378

Clean type

Special model for clean rooms with moving Y-axis carriage installed upward.

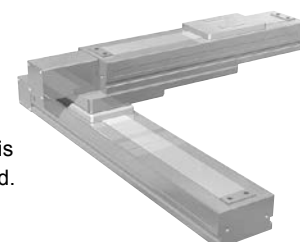

P.480

- Articulated robots
YA
- Linear conveyor models
LCM100
- Motor-less single axis actuator
Robonity
- Compact single-axis robots
TRANSEVO
- Single-axis robots
FLIP-X
- Linear motor single-axis robots
PHASER
- Cartesian robots
XY-X
- SCARA robots
YK-X
- Pick & place robots
YP-X
- CLEAN
- CONTROLLER INFORMATION
- Arm type
- Gantry type
- Moving arm type
- Pole type
- XZ type

A1

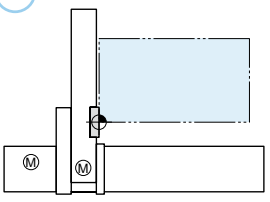

A2

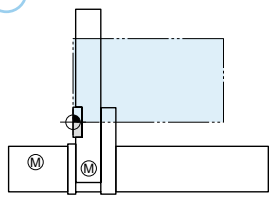

A3

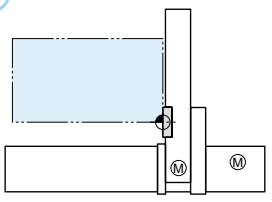

A4

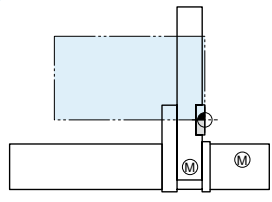

G1

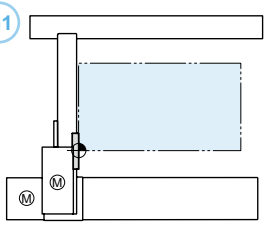

G2

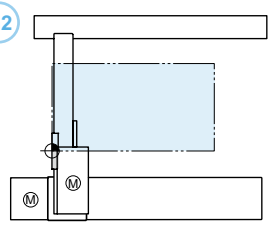

G3

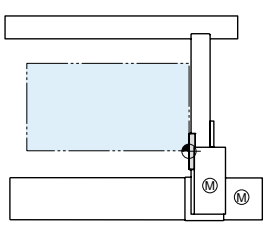

G4

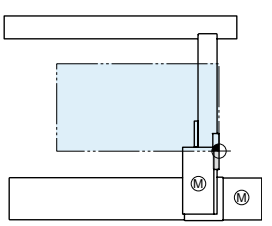

M1

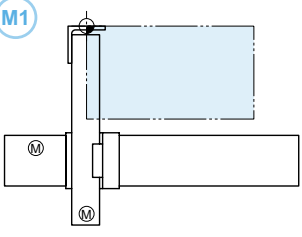

M3

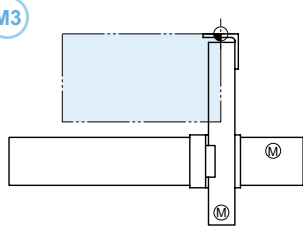

P1

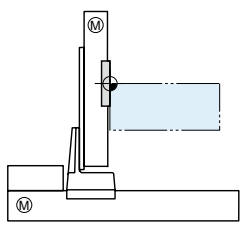

P2

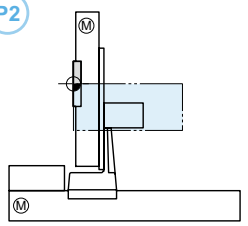

F1

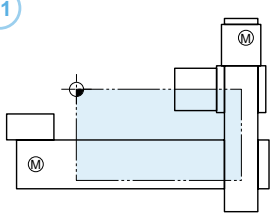

F3

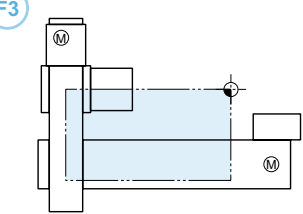

T1

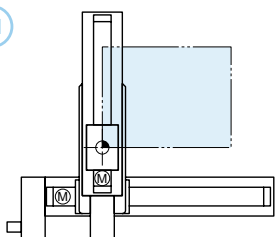

T3

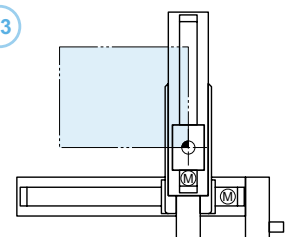

2-axis spec selection guide

Setting method

While checking conditions in order starting from ①, proceed to the right. Select the desired model in ⑥.

① Select the arm variation

Arm type

The type with moving Y-axis carriage.

Gantry type

The type with a guide railing at the end of Y-axis for support.

Moving arm type

The type with a moving Y-axis arm.

Pole type

The type with vertically moving Y-axis carriage.

XZ type

The type with combination of X-axis for horizontal movement and Z-axis for vertical movement.

② Select a line satisfying both the Y-axis stroke and payload and move to the right.

③ Check the cable types

④ Check the X axis stroke

⑤ Select the desired speed

⑥ Decide the model

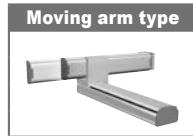
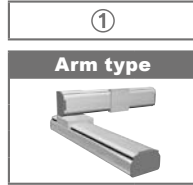

②

Payload (kg)	Y-axis stroke (mm)									
	50	100	150	200	250	300	350	400	450	500
4.5	4.5	3.5	2.5	2	1.5					

Payload (kg)	Y-axis stroke (mm)									
	150	250	350	450	550	650	750	850	950	1050
12	12	11	9	7						
	12	11	9	7						
	7	6	5	3						
	7	6	5	3						
	7	6	5	3						
	20	17	15	13	11	9				
	20	17	15	13	11	9				
	19	16	14	12	10	8				
	14	12	10	8	7					
	25	21	18	16	13	11				
	30	25	20	16						
	30	25	20	16						
	29	24	19	15						
		40	35	30						
	40	35	30							

Payload (kg)	Y-axis stroke (mm)									
	150	250	350	450	550	650	750	850	950	1050
30	30						25	20		
	29						24	19		
							50			
							50			

Payload (kg)	Y-axis stroke (mm)									
	150	250	350	450	550	650	750	850	950	1050
15	15	14	13							
	20									
	30									

Payload (kg)	Y-axis stroke (mm)									
	150	250	350	450	550	650	750	850	950	1050
8	8									
	20									
	20									
	30									
	30									

Payload (kg)	Z-axis stroke (mm)									
	150	250	350	450	550	650	750	850	950	1050
10	10									
	10									
	8									
	3									
	5									
	10									
	8									
	15									
	14	13	12							
	20									
	30									

③
Cable type
Cable carrier

④
X-axis stroke (mm)
150 to 650

⑤
Maximum speed (X-axis / Y-axis) (mm/sec)
720 / 720

⑥ Decide the model	
Model ^(Note 1)	Detailed info page
PXYx-C-A*	P272

Cable type
Cable carrier
Cable carrier
Cable carrier
Whipover
Cable carrier
Cable carrier
Whipover
Cable carrier
Cable carrier
Cable carrier
Cable carrier
Whipover
Cable carrier
Cable carrier
Cable carrier

X-axis stroke (mm)
150 to 1050
150 to 1050
150 to 2450
150 to 950
150 to 2450
150 to 1050
150 to 850
150 to 1050
150 to 3050
500 to 2000
250 to 1250
250 to 850
250 to 1250
250 to 1250
1150 to 2050

Maximum speed (X-axis / Y-axis) (mm/sec)
1200 / 800
1200 / 800
1875 / 1875
1875 / 1875
1875 / 1875
1200 / 1200
1200 / 1200
1200 / 1200
1875 / 1875
1200 / 1200
1200 / 1200
1200 / 1200
1200 / 1200
1200 / 1200
1200 / 1200

Model	Detailed info page
FXyX-C-A*	P274
FXyX-C-A* (I/O)	P276
FXyBx-C-A*	P280
FXyBx-S-A*	P282
FXyYx-C-A* (I/O)	P284
SXYx-C-A*	P286
SXYx-S-A*	P288
SXYx-C-A* (I/O)	P290
SXYBx-C-A*	P304
NXY-C-A*	P312
MXyX-C-A*	P322
MXyX-S-A*	P324
MXyX-C-A* (I/O)	P326
HXYx-C-A*	P332
HXYLx-C-A*	P338

Cable type
Cable carrier
Cable carrier
Cable carrier
Cable carrier

X-axis stroke (mm)
250 to 1050
250 to 1050
250 to 1250
1150 to 2050

Maximum speed (X-axis / Y-axis) (mm/sec)
1200 / 1200
1200 / 1200
1200 / 1200
1200 / 1200

Model	Detailed info page
MXyX-C-G*	P340
MXyX-C-G* (I/O)	P342
HXYx-C-G*	P348
HXYLx-C-G*	P354

Cable type
Cable carrier
Cable carrier
Cable carrier

X-axis stroke (mm)
150 to 850
250 to 1250
250 to 1250

Maximum speed (X-axis / Y-axis) (mm/sec)
1200 / 1200
1200 / 1200
1200 / 1200

Model	Detailed info page
SXYx-C-M*	P356
MXyX-C-M*	P362
HXYx-C-M*	P368

Cable type
Whipover
Cable carrier
Whipover
Cable carrier
Whipover

X-axis stroke (mm)
150 to 850
250 to 1250
250 to 950
250 to 1250
250 to 850

Maximum speed (X-axis / Y-axis) (mm/sec)
1200 / 600
1200 / 600
1200 / 600
1200 / 600
1200 / 600

Model	Detailed info page
SXYx-S-P*	P370
MXyX-C-P*	P371
MXyX-S-P*	P372
HXYx-C-P*	P374
HXYx-S-P*	P375

Cable type
Cable carrier
Whipover
Cable carrier
Cable carrier
Cable carrier
Cable carrier
Cable carrier
Cable carrier
Cable carrier
Cable carrier
Cable carrier
Cable carrier

X-axis stroke (mm)
150 to 1050
150 to 850
150 to 1050
150 to 1050
150 to 1050
150 to 3050
150 to 3050
150 to 1050
150 to 1050
150 to 1050
250 to 1250
250 to 1250

Maximum speed (X-axis / Y-axis) (mm/sec)
1200 / 600
1200 / 600
1200 / 1200
1200 / 1000
1200 / 500
1875 / 600
1875 / 1200
1200 / 600
1200 / 600
1200 / 600
1200 / 600
1200 / 300

Model	Detailed info page
SXYx-C-F* (ZF)	P378
SXYx-S-F* (ZF)	P379
SXYx-C-F* (ZFL20)	P380
SXYx-C-F* (ZS12)	P381
SXYx-C-F* (ZS6)	P381
SXYBx-C-F* (ZF)	P382
SXYBx-C-F* (ZFL20)	P383
MXyX-C-F* (ZFL10)	P384
MXyX-C-F* (ZFH)	P385
HXYx-C-F* (ZL)	P386
HXYx-C-F* (ZH)	P387

Note 1. The figure entered at * inside the form, expresses the arm variation. See P. 262 for more information.

- Articulated robots
YA
- Linear conveyor
modules
LCM100
- Motor-less single
axis actuator
Robonity
- Compact
single-axis robots
TRANSEVO
- Single-axis robots
FLIP-X
- Linear motor
single-axis robots
PHASER
- Cartesian
robots
XX-X
- SCARA
robots
YK-X
- Pick & place
robots
YP-X
- CLEAN
- CONTROLLER
INFORMATION
- Arm type
- Gantry type
- Moving arm
type
- Pole type
- XZ type

3-axis spec selection guide

Setting method

While checking conditions in order starting from ①, proceed to the right. Select the desired model in ⑥.

① Select the arm variation

Arm type

The type with moving Y-axis carriage.

Gantry type

The type with a guide railing at the end of Y-axis for support.

Moving arm type

The type with a moving Y-axis arm.

Pole type

The type with vertically moving Y-axis carriage.

①

Arm type

②

Z-axis

Speed (mm/sec)	Stroke (mm)	Installation method
1000	150	Shaft vertical type
500	150	
800	50 to 300	Clamped base · moving table type (60W)
600	150	Clamped base · moving table type (100W)
	250	
	350	
	150	Clamped base · moving table type (100W)
1200	150	Clamped base · moving table type (200W)
	250	
	350	
600	150	Clamped table · moving base type (200W)
	250	
	350	
1000	150	Shaft vertical type
500	150	
600	150	Clamped base · moving table type (100W)
	250	
	350	
1200	150	Clamped base · moving table type (200W)
	250	
	350	
600	150	Clamped table · moving base type (200W)
	250	
	350	
1000	150	Shaft vertical type
500	150	
1200	150	Clamped base · moving table type (200W)
	250	
	350	
600	150	Clamped table · moving base type (200W)
	250	
	350	
600	150	Clamped base · moving table type (200W)
	250	
	350	
1200	150	Clamped base · moving table type (200W)
	250	
	350	
600	150	Clamped table · moving base type (200W)
	250	
	450	
	550	
300	250	Clamped table · moving base type (200W)
	350	
	450	
	550	

③

Y-axis stroke (mm)

Payload (kg)	150	250	350	450	550	650	750	850	950	1050
		3								
	5				3					
	3									
	10	9	7	5	3					
	10	8	6	4	2					
	10	9	7	5	3	1				
	10	9	7	5	3					
	10	10	8	6	4	2				
	10	9	7	5	3	1				
	8			6	4	2				
	8		7	5	3	1				
	8		6	4	2	1				
	13	10	8	6	4	2				
	12	9	7	5	3	1				
	11	8	6	4	2	1				
	3									
	3									
	5									
	5									
	8	6	4	2	1					
	7	5	3	1						
	6	4	2							
	7	5	3	1						
	6	4	2							
	5	3	1							
	7	5	3	1						
	6	4	2							
	5	3	1							
	3									
	5			4	3					
	8				5	3				
	8			7	4	2				
	8		6	3	1					
	13	12	10	8	5	3				
	13	11	9	7	4	2				
	12	10	8	6	3	1				
	15			12	12	8				
	15			11	11	7				
	15			10	10	6				
	8									
	8					7				
	8					6				
	14			12	8					
	13			11	7					
	12			10	6					
	20				18					
	20				17					
	20			19	16					
	20			18	15					
	25			20	18					
	25			20	17					
	24			19	16					
	23			18	15					

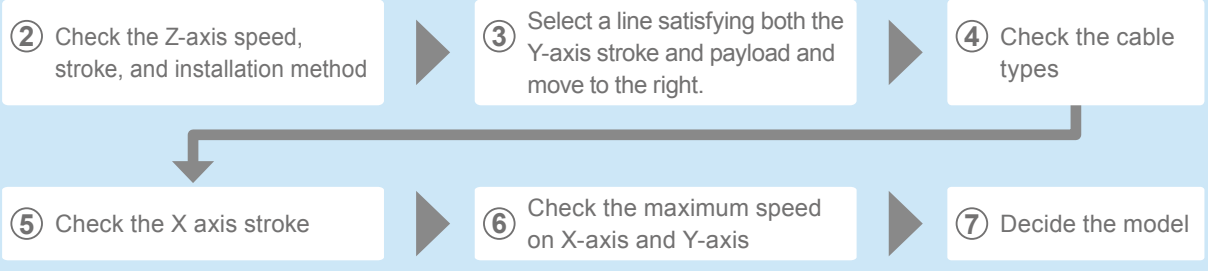

④	⑤	⑥	⑦ Decide the model	
Cable type	X-axis stroke (mm)	Maximum speed (X-axis / Y-axis) (mm/sec)	Model ^(Note 1)	Detailed info page
Cable carrier	150 to 1050	1200 / 800	FXYx-C-A*-ZS12	P.277
			FXYx-C-A*-ZS6	P.277
			FXYx-C-A*-ZT6L	P.278
Cable carrier	150 to 1050	1200 / 1200	SXYx-C-A*-ZF	P.292
Whipover	150 to 850	1200 / 1200	SXYx-S-A*-ZF	P.293
Cable carrier	150 to 1050	1200 / 1200	SXYx-C-A*-ZFL20	P.294
Cable carrier	150 to 1050	1200 / 1200	SXYx-C-A*-ZFH	P.295
Cable carrier	150 to 1050	1200 / 1200	SXYx-C-A*-ZS12	P.296
Whipover	150 to 850		SXYx-S-A*-ZS12	P.296
Cable carrier	150 to 1050		SXYx-C-A*-ZS6	P.297
Whipover	150 to 850		SXYx-S-A*-ZS6	P.297
Cable carrier	150 to 3050	1875 / 1875	SXYBx-C-A*-ZF	P.306
Cable carrier	150 to 3050	1875 / 1875	SXYBx-C-A*-ZFL20	P.307
Cable carrier	150 to 3050	1875 / 1875	SXYBx-C-A*-ZFH	P.308
Cable carrier	150 to 3050	1875 / 1875	SXYBx-C-A*-ZS12	P.309
Cable carrier	150 to 3050	1875 / 1875	SXYBx-C-A*-ZS6	P.309
Cable carrier	500 to 2000	1200 / 1200	NXY-C-A*-ZFL20	P.314
Cable carrier	500 to 2000	1200 / 1200	NXY-C-A*-ZFH	P.316
Cable carrier	250 to 1250	1200 / 1200	MXYx-C-A*-ZFL10	P.327
Cable carrier	250 to 1250	1200 / 1200	MXYx-C-A*-ZFL20	P.327
Cable carrier	250 to 1250	1200 / 1200	MXYx-C-A*-ZFH	P.328
Cable carrier	250 to 1250	1200 / 1200	HXYx-C-A*-ZL	P.334
Cable carrier	250 to 1250	1200 / 1200	HXYx-C-A*-ZH	P.335

Note 1. The figure entered at * inside the form, expresses the arm variation. See P.262 for more information.

3-axis spec selection guide

①

Gantry type

Z-axis		
Speed (mm/sec)	Stroke (mm)	Installation method
600	150	Clamped base · moving table type (200W)
	250	
	350	
1200	150	Clamped base · moving table type (200W)
	250	
	350	
600	150	Clamped table · moving base type (200W)
	250	
	350	
600	250	Clamped base · moving table type (200W)
	350	
	450	
	550	
300	250	Clamped table · moving base type (200W)
	350	
	450	
	550	

③

Payload (kg)	Y-axis stroke (mm)										
	150	250	350	450	550	650	750	850	950	1050	
Payload (kg)	15							12			
	15							11			
	15							10			
	8										
	8										
	8										
	14							12			
	13							11			
	12							10			
	20										
	20										
	20										
20											
30											
30											
30											
30											

Moving arm type

Z-axis		
Speed (mm/sec)	Stroke (mm)	Installation method
600	150	Clamped base · moving table type (100W)
	250	
	350	
1200	150	Clamped base · moving table type (200W)
	250	
	350	
600	150	Clamped table · moving base type (200W)
	250	
	350	
1000	150	Shaft vertical type
500	150	
600	150	Clamped base · moving table type (200W)
	250	
	350	
1200	150	Clamped base · moving table type (200W)
	250	
	350	
600	150	Clamped table · moving base type (200W)
	250	
	350	
300	250	Clamped table · moving base type (200W)
	350	
	450	
	550	

Payload (kg)	Y-axis stroke (mm)									
	150	250	350	450	550	650	750	850	950	1050
Payload (kg)	9	8	7							
	8	7	6							
	7	6	5							
	8	8	7							
	8	7	6							
	7	6	5							
	9	8	7							
	8	7	6							
	7	6	5							
	3									
	5									
	12									
	11									
	10									
	8									
	12									
	11									
	10									
18										
18				17						
18				16						
18				15						

Pole type

Z-axis		
Speed (mm/sec)	Stroke (mm)	Installation method
1200	150	Clamped table · moving base type (200W)
	250	
	350	
1200	250	Clamped table · moving base type (200W)
	350	
	450	
	550	
	650	
1200	250	Clamped table · moving base type (200W)
	350	
	450	
	550	
	650	

Payload (kg)	Y-axis stroke (mm)										
	150	250	350	450	550	650	750	850	950	1050	
Payload (kg)	10										
	9										
	8										
	15										
	15										
	15										
	15										
	15										
	15										
	15										
	15										

④	⑤	⑥	⑦ Decide the model	
Cable type	X-axis stroke (mm)	Maximum speed (X-axis / Y-axis) (mm/sec)	Model ^(Note 1)	Detailed info page
Cable carrier	250 to 1050	1200 / 1200	MXYx-C-G*-ZFL10	P.343
Cable carrier	250 to 1050	1200 / 1200	MXYx-C-G*-ZFL20	P.343
Cable carrier	250 to 1050	1200 / 1200	MXYx-C-G*-ZFH	P.344
Cable carrier	250 to 1250	1200 / 1200	HXYx-C-G*-ZL	P.350
Cable carrier	250 to 1250	1200 / 1200	HXYx-C-G*-ZH	P.351

Cable type	X-axis stroke (mm)	Maximum speed (X-axis / Y-axis) (mm/sec)	Model ^(Note 1)	Detailed info page
Whipover	150 to 850	1200 / 1200	SXYx-S-M*-ZF	P.358
Whipover	150 to 850	1200 / 1200	SXYx-S-M*-ZFL20	P.359
Whipover	150 to 850	1200 / 1200	SXYx-S-M*-ZFH	P.360
Whipover	150 to 850	1200 / 1200	SXYx-S-M*-ZS12	P.361
Whipover	150 to 850	1200 / 1200	SXYx-S-M*-ZS6	P.361
Cable carrier	250 to 1250	1200 / 1200	MXYx-C-M*-ZFL10	P.364
Cable carrier	250 to 1250	1200 / 1200	MXYx-C-M*-ZFL20	P.364
Cable carrier	250 to 1250	1200 / 1200	MXYx-C-M*-ZFH	P.365
Cable carrier	250 to 1250	1200 / 1200	HXYx-C-M*-ZH	P.368

Note 1. The figure entered at * inside the form, expresses the arm variation. See P.262 for more information.

Cable type	X-axis stroke (mm)	Maximum speed (X-axis / Y-axis) (mm/sec)	Model	Detailed info page
Cable carrier	250 to 1250	1200 / 600	MXYx-C-P2-ZPMH	P.373
Cable carrier	250 to 1250	1200 / 600	HXYx-C-P2-ZPH	P.376
Whipover	250 to 850	1200 / 600	HXYx-S-P1-ZPH	P.377

Robot ordering method description

In the order format for the YAMAHA cartesian robots XY-X series, the notation (letters/numbers) for the mechanical section is shown linked to the controller section notation.

[Example]

■ 2-axis specifications

● Mechanical ▶ FXYx (Arm type)

- Cable variations ▷ Cable carrier
- Combination (Arm variations) ▷ A1
- X-axis stroke ▷ 450mm
- Y-axis stroke ▷ 350mm
- Robot cable length ▷ 3.5M

● Controller ▶ RCX320

● Ordering method

FXYx - C - A1 - 45 - 35 - 3L - RCX320

Mechanical section

Controller section

To find detailed controller information see the controller page. **RCX320 ▶ P.548**, **RCX222 ▶ P.558**

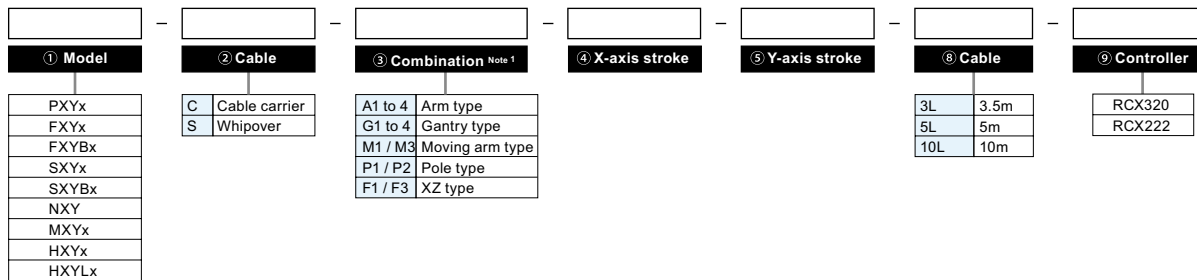

Note 1. To find detailed information on arm variations (combinations) see P.262.

[Example]

■ 3 / 4-axis specifications

● Mechanical ▶ SXYx (Moving arm type)

- Cable variations ▷ Whipover
- Combination (Arm variations) ▷ M3
- X-axis stroke ▷ 850mm
- Y-axis stroke ▷ 150mm
- Z-axis stroke ▷ 150mm
- Robot cable length ▷ 5M

● Controller ▶ RCX340

● Ordering method

SXYx - S - M3 - 85 - 15 - ZFH - 15 - 5L - RCX340





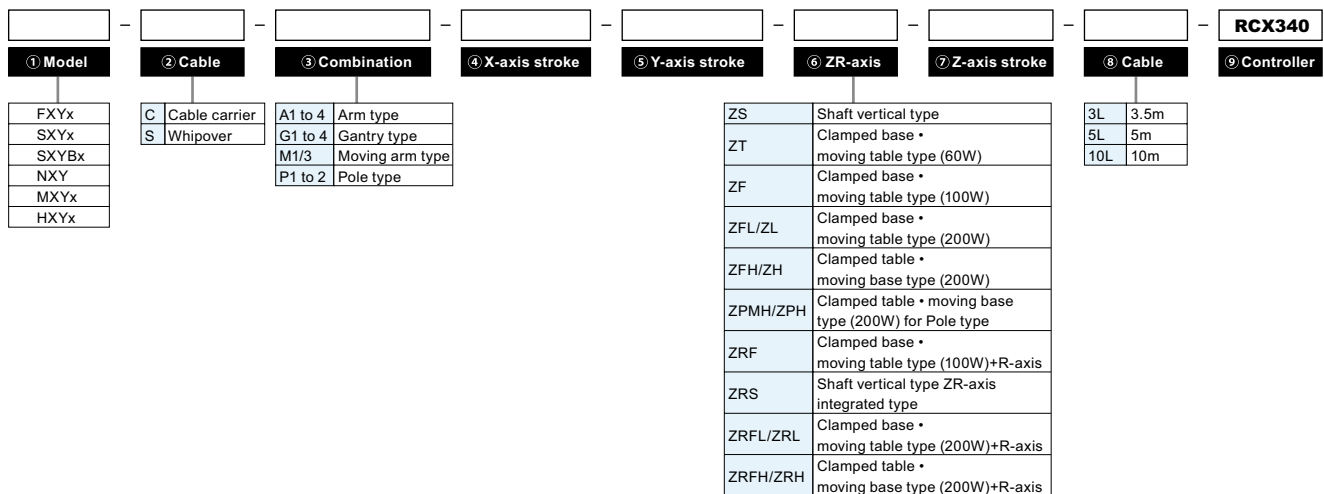

Mechanical section

Controller section

To find detailed controller information see the controller page. **RCX340 ▶ P.566**



Robot ordering method terminology

① Model	Enter the robot unit model.
② Cable	Cable specs can be selected. To find detailed information see P.262. C: Cable carrier S: Whipover
③ Combination (Arm variations)	<p>Select the arm variation and combination method.</p> <div style="display: flex; justify-content: space-around; align-items: flex-start;"> <div style="text-align: center;"> <p>●Arm type The type with moving Y-axis carriage.</p>  </div> <div style="text-align: center;"> <p>●Gantry type The type with a guide railing at the end of Y-axis for support.</p>  </div> <div style="text-align: center;"> <p>●Moving arm type The type with a moving Y-axis arm.</p>  </div> <div style="text-align: center;"> <p>●Pole type The type with vertically moving Y-axis carriage.</p>  </div> <div style="text-align: center;"> <p>●XZ type The type with combination of X-axis for horizontal movement and Z-axis for vertical movement.</p>  </div> <div style="text-align: center;"> <p>●Clean type Special model for clean rooms with moving Y-axis carriage installed upward.</p>  </div> </div> <p>To find information on combinations see P.262.</p>
④ X-axis stroke	Select the X axis stroke. Enter in centimeters (cm). (For example enter 50 for a stroke of 500mm.)
⑤ Y-axis stroke	Select the Y axis stroke. Enter in centimeters (cm). (For example enter 50 for a stroke of 500mm.)
⑥ ZR-axis	<p>Select the Z axis installation direction. The R axis is installed with 4-axis specifications. To find more information see P.43.</p> <p>[3-axes]</p> <p>ZS : Shaft vertical type ZT : Clamped base · moving table type (60W) ZF : Clamped base · moving table type (100W) ZFL/ZL : Clamped base · moving table type (200W) ZFH/ZH : Clamped table · moving base type (200W) ZPMH/ZPH : Clamped table · moving base type (200W) for pole type</p> <p>[4-axes]</p> <p>ZRF : Clamped base · moving table type (100W)+R axis ZRS : ZR axis integrated type ZRL/ZRFL : Clamped base · moving table type (200W)+R axis ZRH/ZRFH : Clamped table · moving base type (200W)+R axis</p>
⑦ Z-axis stroke	Select the Z axis stroke. Enter in centimeters (cm). (For example enter 15 for a stroke of 150mm.)
⑧ Cable	Select the length of the robot cable connecting the robot and controller. 3L : 3.5m 5L : 5m 10L : 10m
⑨ Controller	2-axis specifications: Select either the RCX320 or RCX222. 3 / 4-axis specifications: Select the RCX340.

Articulated robots
YA
Linear conveyor modules
LCM100
Motor-less single axis actuator
Robonity
Compact single-axis robots
TRANSEVO
Single-axis robots
FLIP-X
Linear motor single-axis robots
PHASER
Cartesian robots
XX-X
SCARA robots
YK-X
Pick & place robots
YP-X
Linear
CLEAN
CONTROLLER
INFORMATION
Arm type
Gantry type
Moving arm type
Pole type
XZ type

PXYx 2 axes

- Arm type
- Cable carrier



Ordering method

PXYx - C

Model	Cable	Combination	X-axis stroke	Y-axis stroke	Cable
A1			15 to 65cm	5 to 30cm	3L: 3.5m
A2					5L: 5m
A3					10L: 10m
A4					

RCX320-2

Controller / Number of controllable axes	Safety standard	Option A (OP.A)	Option B (OP.B)	Vision System	Absolute battery

Specify various controller setting items. RCX320 ▶ **P.548**

RCX222

Controller	Usable for CE	I/O selection 1	I/O selection 2

Specify various controller setting items. RCX222 ▶ **P.558**

Specification

	X-axis	Y-axis
Axis construction <small>Note 1</small>	—	T4H
AC servo motor output (W)	60	30
Repeatability <small>Note 2</small> (mm)	+/-0.02	+/-0.02
Drive system	Ball screw φ12	Ball screw φ8
Ball screw lead <small>Note 3</small> (Deceleration ratio) (mm)	12	12
Maximum speed <small>Note 4</small> (mm/sec)	720	720
Moving range (mm)	150 to 650	50 to 300
Robot cable length (m)	Standard: 3.5 Option: 5,10	

- Note 1. Use caution that the flame machining (installation holes, tap holes) differs from single-axis robots.
 Note 2. Positioning repeatability in one direction.
 Note 3. Leads not listed in the catalog are also available. Contact us for details.
 Note 4. When the X-axis stroke is longer than 650mm, resonance of the ball screw may occur depending on the operation conditions (critical speed). In this case, reduce the speed setting on the program by referring to the maximum speeds shown in the table below.

Maximum payload (kg)

Y stroke (mm)	XY 2 axes
50	4.5
100	4.5
150	3.5
200	2.5
250	2
300	1.5

Controller

Controller	Operation method
RCX320	Programming / I/O point trace / Remote command / Operation using RS-232C communication
RCX222	

PXYx 2 axes A1

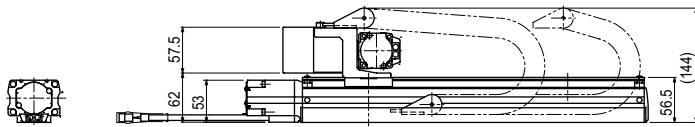
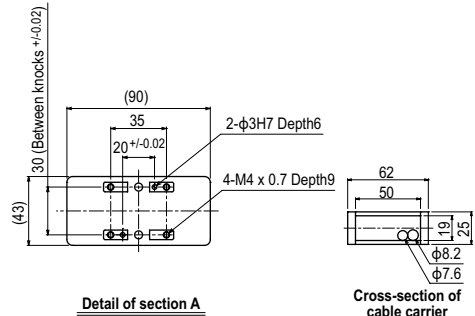
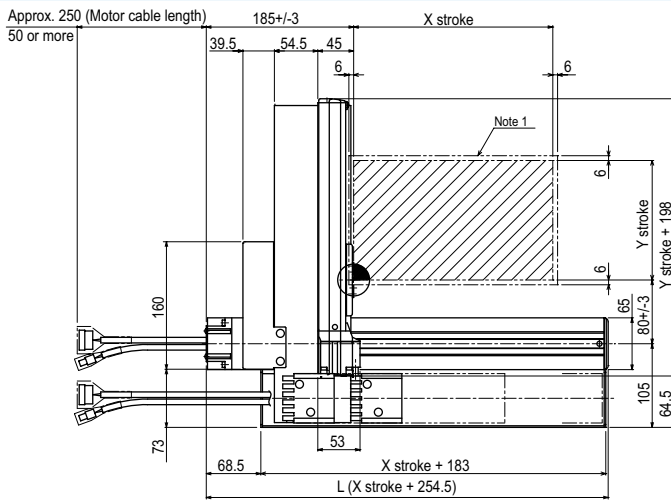

Use M4 x 0.7 hex socket head bolt with length head bolt with length (under head) of 15mm or more.

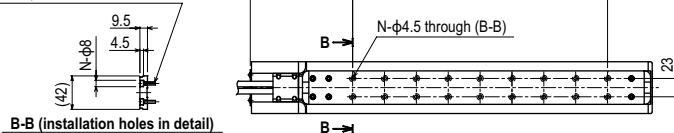

X stroke	150	250	350	450	550	650
L	404.5	504.5	604.5	704.5	804.5	904.5
M	5	8	10	13	15	18
N	12	18	22	28	32	38
Y stroke	50	100	150	200	250	300
Maximum speed for each stroke (mm/sec) <small>Note 2</small>	720					600
Speed setting	—					83%

Note 1. The moving range when returning to origin and the stop position when stopping by the mechanical stopper.

Note 2. When the X-axis stroke is longer than 650mm, resonance of the ball screw may occur depending on the operation conditions (critical speed). In this case, reduce the speed setting on the program by referring to the maximum speeds shown in the table at the left.

PXYx 2 axes A2

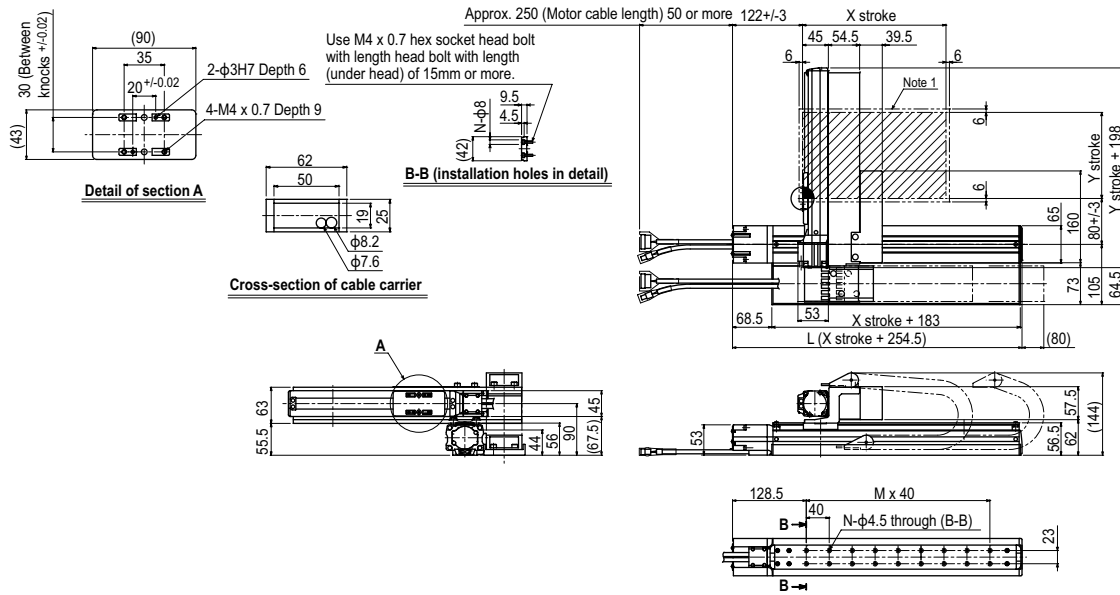

PXYx 2 axes A3

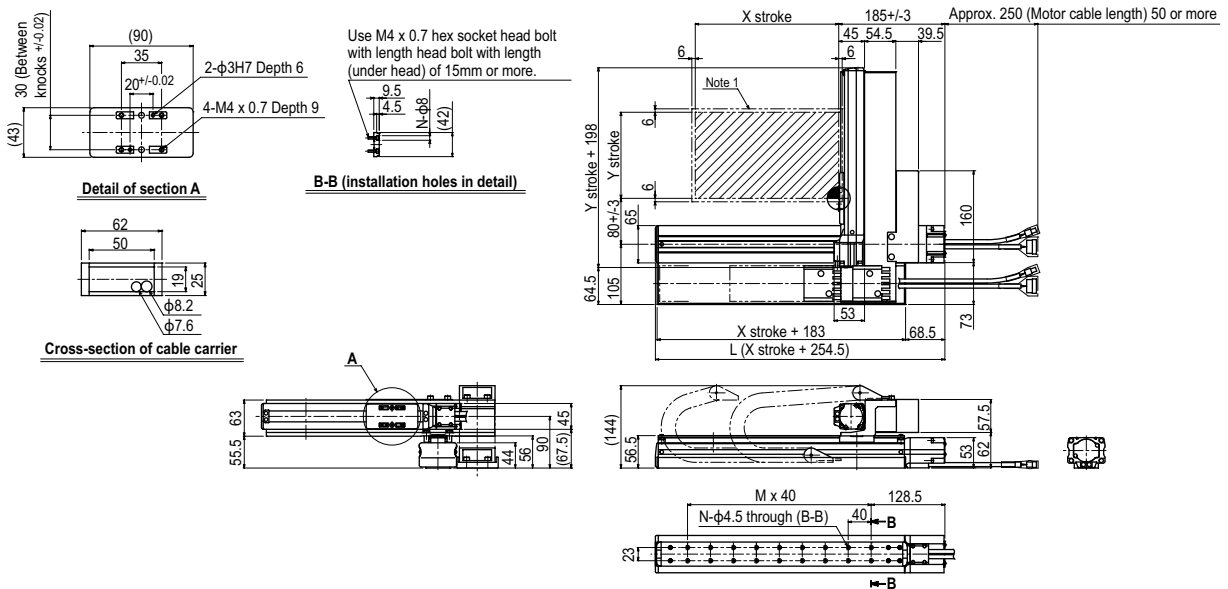

PXYx 2 axes A4

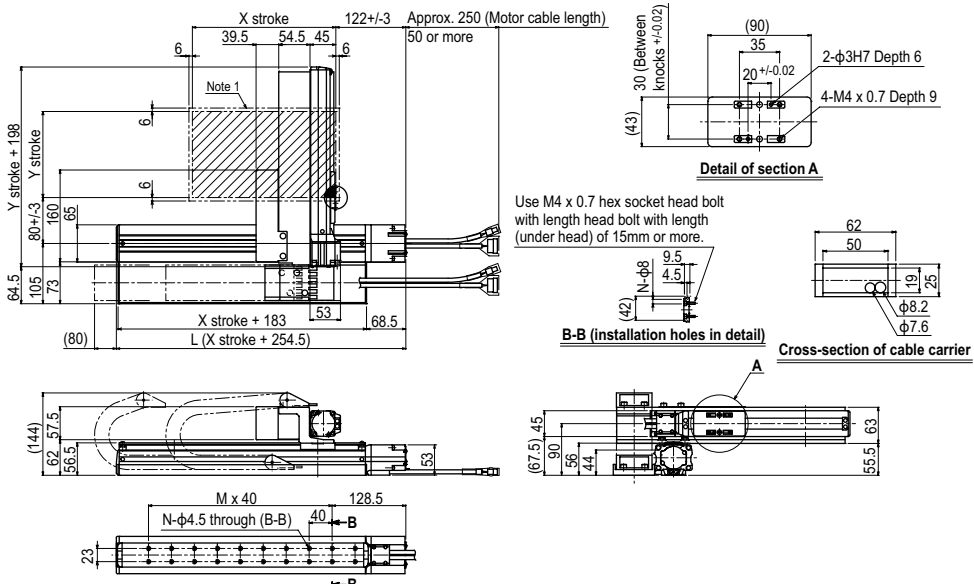

FXYx 2 axes

● Arm type ● Cable carrier



Ordering method

FXYx - C

Model	Cable	Combination	X-axis stroke	Y-axis stroke	Cable
A1			15 to 105cm	15 to 55cm	3L: 3.5m
A2					5L: 5m
A3					10L: 10m
A4					

RCX320-2

Controller / Number of controllable axes	Safety standard	Option A (OP.A)	Option B (OP.B)	Vision System	Absolute battery

Specify various controller setting items. RCX320 ▶ P.548

RCX222

Controller	Usable for CE	I/O selection 1	I/O selection 2

Specify various controller setting items. RCX222 ▶ P.558

Specification

	X-axis	Y-axis
Axis construction	—	—
AC servo motor output (W)	100	60
Repeatability ^{Note 1} (mm)	+/-0.01	+/-0.02
Drive system	Ball screw φ15	Ball screw φ12
Ball screw lead ^{Note 2} (Deceleration ratio) (mm)	20	12
Maximum speed ^{Note 3} (mm/sec)	1200	800
Moving range (mm)	150 to 1050	150 to 550
Robot cable length (m)	Standard: 3.5 Option: 5,10	

Note 1. Positioning repeatability in one direction.
 Note 2. Leads not listed in the catalog are also available. Contact us for details.
 Note 3. When the X-axis stroke is longer than 750mm, resonance of the ball screw may occur depending on the operation conditions (critical speed). In this case, reduce the speed setting on the program by referring to the maximum speeds shown in the table below.

Maximum payload (kg)

Y stroke (mm)	XY 2 axes
150	12
250	12
350	11
450	9
550	7

Controller

Controller	Operation method
RCX320 RCX222	Programming / I/O point trace / Remote command / Operation using RS-232C communication

FXYx 2 axes (A1)

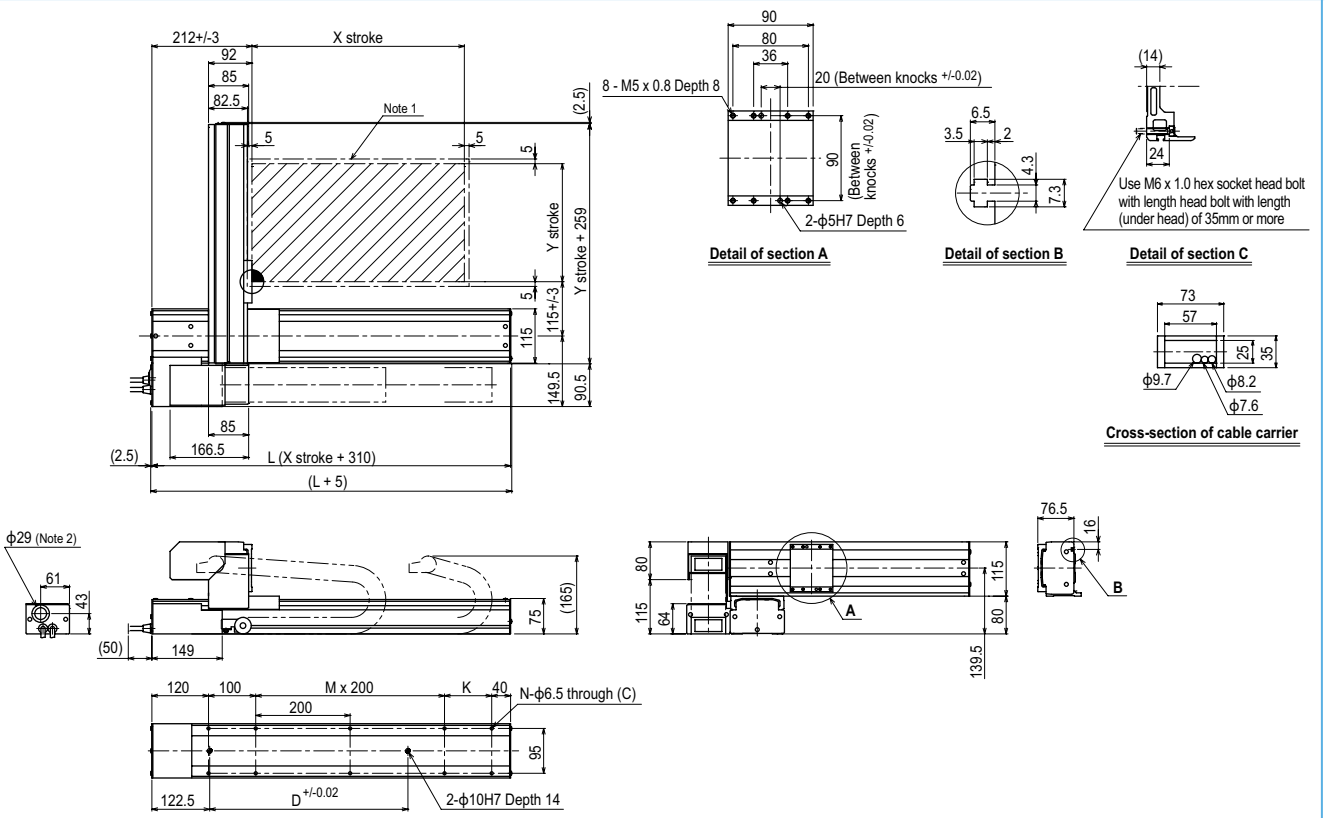

X stroke	Y stroke										
	150	250	350	450	550	650	750	850	950	1050	
L	460	560	660	760	860	960	1060	1160	1260	1360	
K	200	100	200	100	200	100	200	100	200	100	
D	240	240	420	420	600	600	780	960	960	1140	
M	0	1	1	2	2	3	3	4	4	5	
N	6	8	8	10	10	12	12	14	14	16	
Y stroke	150	250	350	450	550						
Maximum speed for each stroke (mm/sec)	X-axis	1200				960		780	600	540	
	Speed setting	—				80%		65%	50%	45%	

Note 1. The moving range when returning to origin and the stop position when stopping by the mechanical stopper.
 Note 2. User cable extraction port.

Note 3. When the X-axis stroke is longer than 750mm, resonance of the ball screw may occur depending on the operation conditions (critical speed). In this case, reduce the speed setting on the program by referring to the maximum speeds shown in the table at the left.

FXYx 2 axes A2

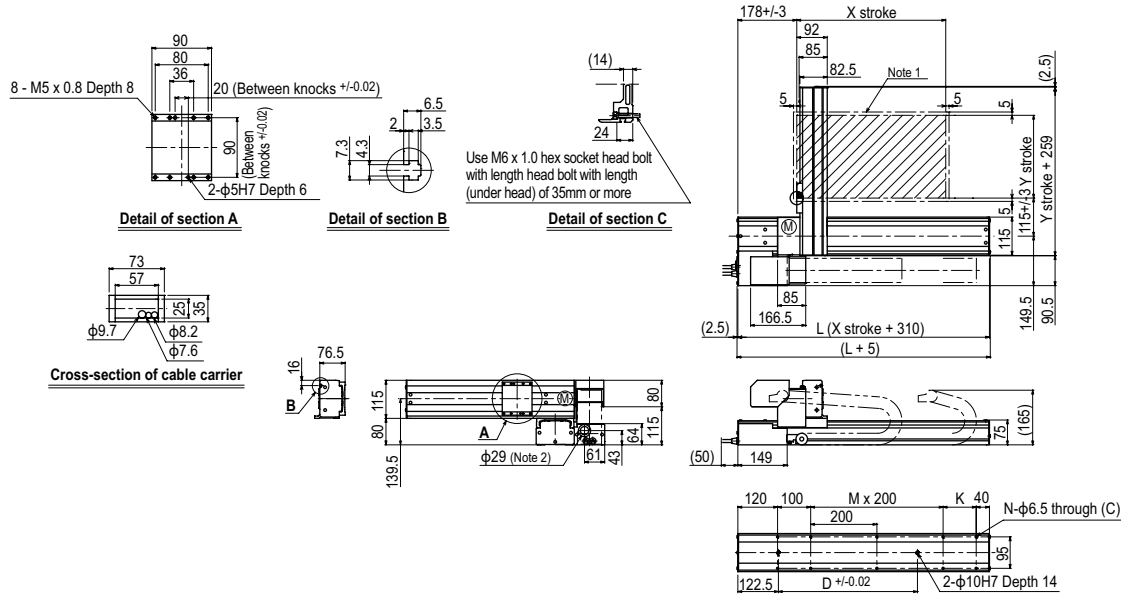

FXYx 2 axes A3

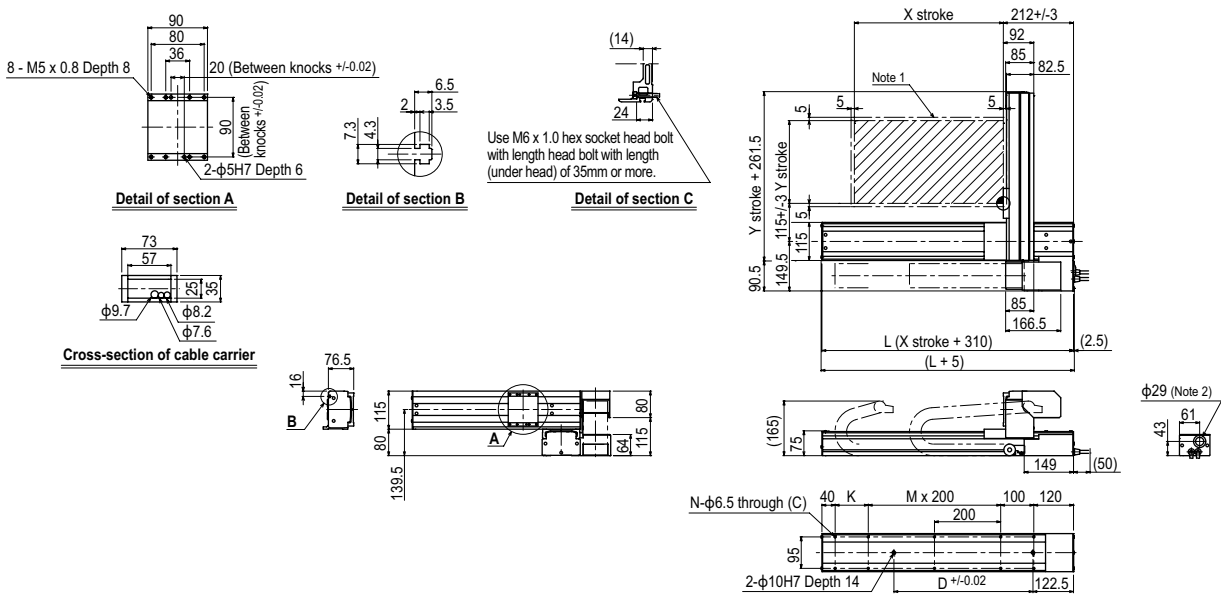

FXYx 2 axes A4

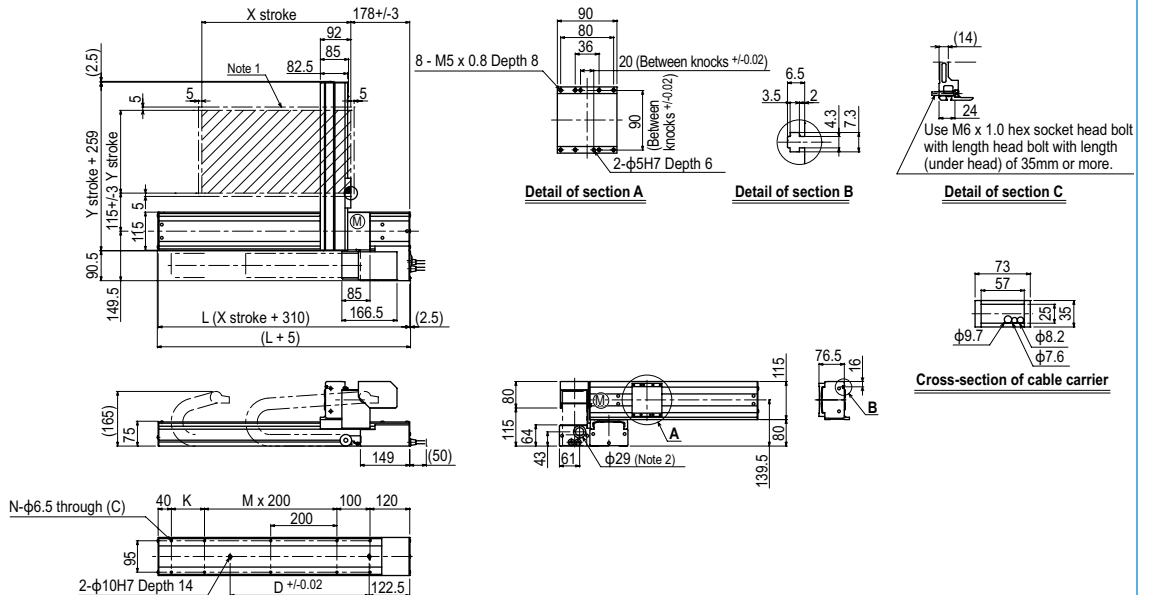

FXYx 2 axes / IO

- Arm type
- Cable carrier
- Type with Y-axis I/O cable carrier added

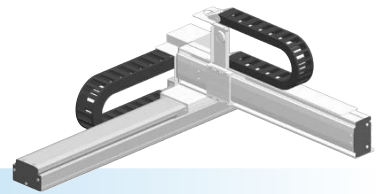

Ordering method

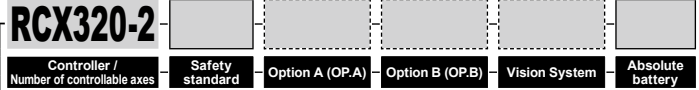
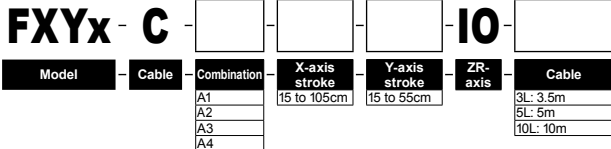

Specify various controller setting items. RCX320 ▶ **P.548**

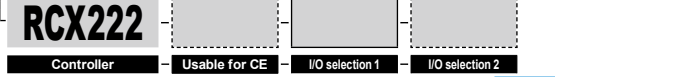

Specify various controller setting items. RCX222 ▶ **P.558**

Specification

	X-axis	Y-axis
Axis construction	—	—
AC servo motor output (W)	100	60
Repeatability ^{Note 1} (mm)	+/-0.01	+/-0.02
Drive system	Ball screw φ15	Ball screw φ12
Ball screw lead ^{Note 2} (Deceleration ratio) (mm)	20	12
Maximum speed ^{Note 3} (mm/sec)	1200	800
Moving range (mm)	150 to 1050	150 to 550
Robot cable length (m)	Standard: 3.5 Option: 5, 10	

Note 1. Positioning repeatability in one direction.
 Note 2. Leads not listed in the catalog are also available. Contact us for details.
 Note 3. When the X-axis stroke is longer than 750mm, resonance of the ball screw may occur depending on the operation conditions (critical speed). In this case, reduce the speed setting on the program by referring to the maximum speeds shown in the table below.

Maximum payload (kg)

Y stroke (mm)	XY 2 axes
150	12
250	12
350	11
450	9
550	7

Controller

Controller	Operation method
RCX320 RCX222	Programming / I/O point trace / Remote command / Operation using RS-232C communication

FXYx 2 axes / IO A1

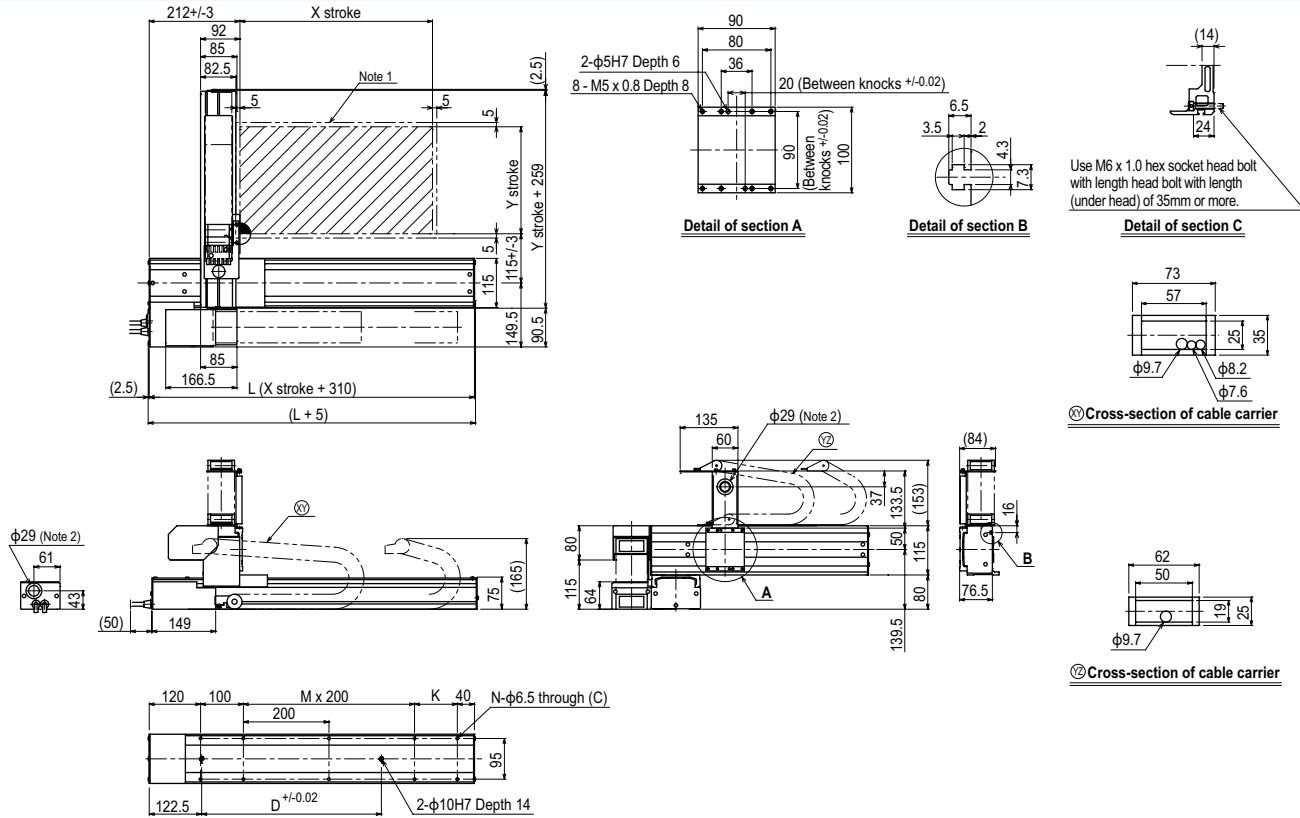

X stroke	Y stroke									
	150	250	350	450	550	650	750	850	950	1050
L	460	560	660	760	860	960	1060	1160	1260	1360
K	200	100	200	100	200	100	200	100	200	100
D	240	240	420	420	600	600	780	960	960	1140
M	0	1	1	2	2	3	3	4	4	5
N	6	8	8	10	10	12	12	14	14	16
Y stroke	150	250	350	450	550					
Maximum speed for each stroke (mm/sec) ^{Note 3}	X-axis		1200			960		780	600	540
Speed setting			—			80%		65%	50%	45%

Note 1. The moving range when returning to origin and the stop position when stopping by the mechanical stopper.
 Note 2. User cable extraction port.

Note 3. When the X-axis stroke is longer than 750mm, resonance of the ball screw may occur depending on the operation conditions (critical speed). In this case, reduce the speed setting on the program by referring to the maximum speeds shown in the table at the left.

FXYx 3 axes / ZS

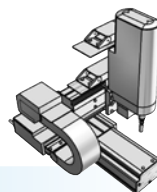

- Arm type
- Cable carrier
- Z-axis shaft vertical type

Ordering method

FXYx - C [] [] [] [] **15** [] **RCX340-3** [] [] [] [] [] [] [] [] []

Model	Cable	Combination	X-axis stroke	Y-axis stroke	ZR-axis	Z-axis stroke	Cable	Controller / Number of controllable axes	Safety standard	Option A (OP.A)	Option B (OP.B)	Option C (OP.C)	Option D (OP.D)	Option E (OP.E)	Absolute battery
A1			15 to 105cm	15 to 55cm	ZS12		3L: 3.5m 5L: 5m 10L: 10m								
A2					ZS6										
A3															
A4															

Specify various controller setting items. RCX340 ▶ P.566

Specification

	X-axis	Y-axis	Z-axis: ZS12	Z-axis: ZS6
Axis construction	-	-	-	
AC servo motor output (W)	100	60	60	
Repeatability ^{Note 1} (mm)	+/-0.01	+/-0.02	+/-0.02	
Drive system	Ball screw φ15	Ball screw φ12	Ball screw φ12	
Ball screw lead ^{Note 2} (Deceleration ratio) (mm)	20	12	12	6
Maximum speed ^{Note 3} (mm/sec)	1200	800	1000	500
Moving range (mm)	150 to 1050	150 to 550	150	
Robot cable length (m)	Standard: 3.5 Option: 5,10			

Note 1. Positioning repeatability in one direction.
 Note 2. Leads not listed in the catalog are also available. Contact us for details.
 Note 3. When the X-axis stroke is longer than 750mm, resonance of the ball screw may occur depending on the operation conditions (critical speed). In this case, reduce the speed setting on the program by referring to the maximum speeds shown in the table below.

Maximum payload (kg)

Y stroke (mm)	ZS12	ZS6
150	3	5
250	3	5
350	3	5
450	3	5
550	3	3

Controller

Controller	Operation method
RCX340	Programming / I/O point trace / Remote command / Operation using RS-232C communication

FXYx 3 axes / ZS A1

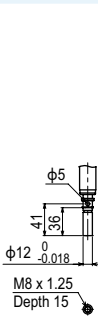
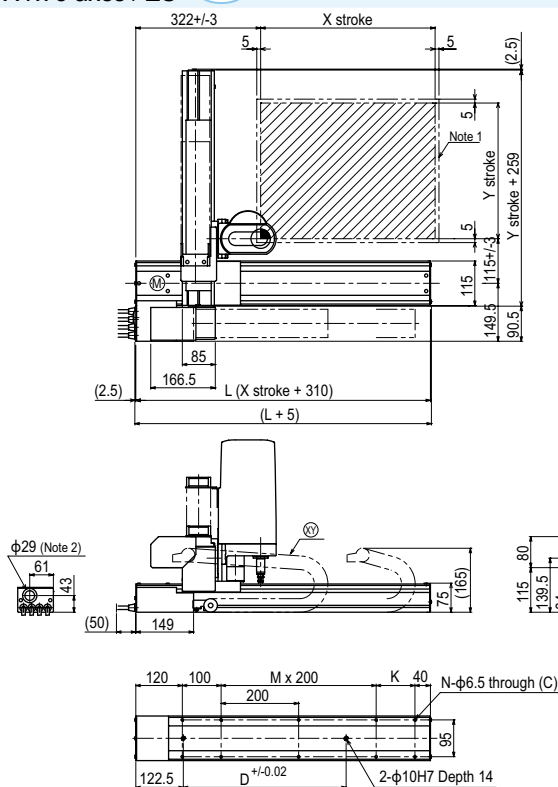

Detail of section A

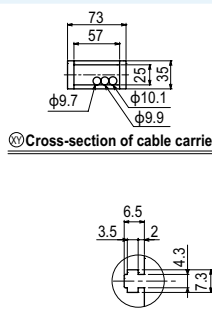

Detail of section B

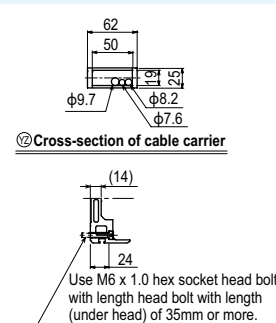

Detail of section C

X stroke	150	250	350	450	550	650	750	850	950	1050		
L	460	560	660	760	860	960	1060	1160	1260	1360		
K	200	100	200	100	200	100	200	100	200	100		
D	240	240	420	420	600	600	780	960	960	1140		
M	0	1	1	2	2	3	3	4	4	5		
N	6	8	8	10	10	12	12	14	14	16		
Y stroke	150	250	350	450	550							
Z stroke	150											
Maximum speed for each stroke (mm/sec) ^{Note 3}	X-axis		1200				960	780	600	540		
Speed setting			-				80%	65%	50%	45%		

Note 1. The moving range when returning to origin and the stop position when stopping by the mechanical stopper.
 Note 2. User cable extraction port.

Note 3. When the X-axis stroke is longer than 750mm, resonance of the ball screw may occur depending on the operation conditions (critical speed). In this case, reduce the speed setting on the program by referring to the maximum speeds shown in the table at the left.

Articulated robots
YA
 Linear conveyor modules
LCM100
 Motor-less single axis actuator
Robonity
 Compact single-axis robots
TRANSEVO
 Single-axis robots
FLIP-X
 Linear motor single-axis robots
PHASER
 Cartesian robots
XY-X
 SCARA robots
YK-X
 Pick & place robots
YP-X
CLEAN
CONTROLLER INFORMATION
 Arm type
 Gantry type
 Moving arm type
 Pole type
XZ type

FXYx 3 axes / ZT

- Arm type
- Cable carrier
- Z-axis: clamped base / moving table type (60W)

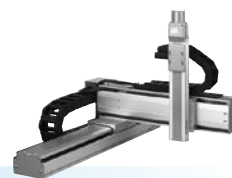

Ordering method

FXYx - C - **ZT6L - 12** - **RCX340-3**

Model	Cable	Combination	X-axis stroke	Y-axis stroke	ZR-axis	Lead	Z-axis stroke	Cable	Controller / Number of controllable axes	Safety standard	Option A (OP.A)	Option B (OP.B)	Option C (OP.C)	Option D (OP.D)	Option E (OP.E)	Absolute battery
		A1	15 to 105cm	15 to 55cm			5 to 30cm	3L: 3.5m 5L: 5m 10L: 10m								

Specify various controller setting items. RCX340 ▶ **P.566**

Specification

	X-axis	Y-axis	Z-axis
Axis construction ^{Note 1}	-	-	T6L-12-BK
AC servo motor output (W)	100	60	60
Repeatability ^{Note 2} (mm)	+/-0.01	+/-0.02	+/-0.02
Drive system	Ball screw φ15	Ball screw φ12	Ball screw φ12
Ball screw lead ^{Note 3} (Deceleration ratio) (mm)	20	12	12
Maximum speed ^{Note 4} (mm/sec)	1200	800	800
Moving range (mm)	150 to 1050	150 to 550	50 to 300
Robot cable length (m)	Standard: 3.5 Option: 5,10		

Note 1. Use caution that the flame machining (installation holes, tap holes) differs from single-axis robots.
 Note 2. Positioning repeatability in one direction.
 Note 3. Leads not listed in the catalog are also available. Contact us for details.
 Note 4. When the X-axis stroke is longer than 750mm, resonance of the ball screw may occur depending on the operation conditions (critical speed). In this case, reduce the speed setting on the program by referring to the maximum speeds shown in the table below.

Maximum payload (kg)

Y stroke (mm)	ZT
150 to 550	3

Controller

Controller	Operation method
RCX340	Programming / I/O point trace / Remote command / Operation using RS-232C communication

FXYx 3 axes / ZT A1

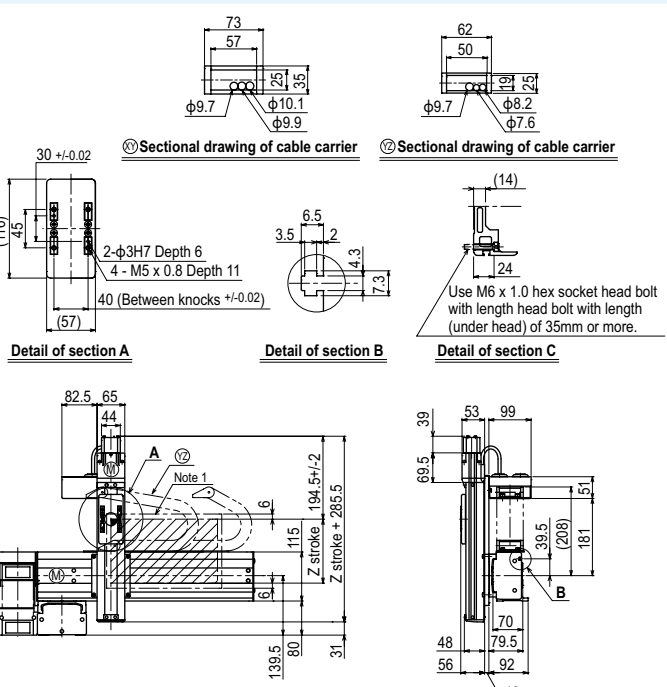
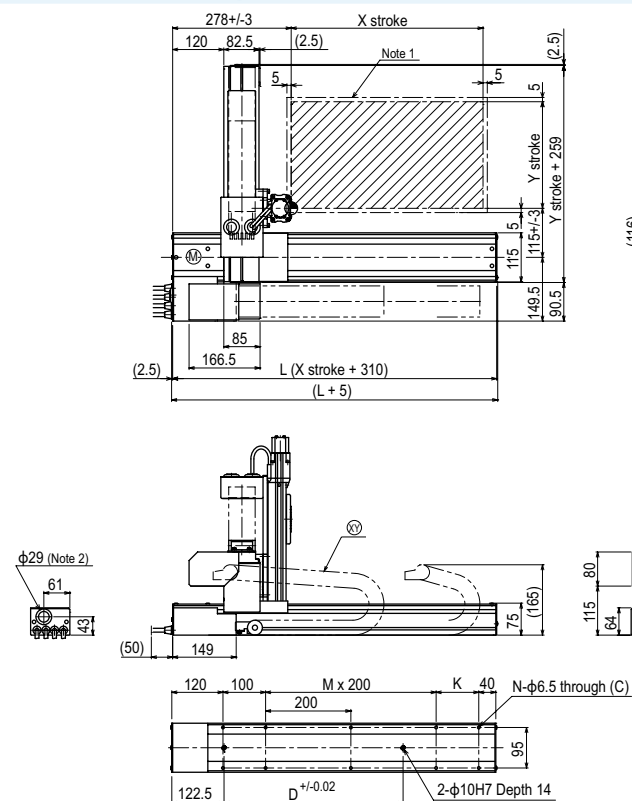

X stroke	150	250	350	450	550	650	750	850	950	1050
L	460	560	660	760	860	960	1060	1160	1260	1360
K	200	100	200	100	200	100	200	100	200	100
D	240	240	420	420	600	600	780	960	960	1140
M	0	1	1	2	2	3	3	4	4	5
N	6	8	8	10	10	12	12	14	14	16
Y stroke	150	250	350	450	550					
Z stroke	50	100	150	200	250	300				
Maximum speed for each stroke (mm/sec) ^{Note 1}	1200					960	780	600	540	
Speed setting	-					80%	65%	50%	45%	

Note 1. The moving range when returning to origin and the stop position when stopping by the mechanical stopper.
 Note 2. User cable extraction port.

Note 3. When the X-axis stroke is longer than 750mm, resonance of the ball screw may occur depending on the operation conditions (critical speed). In this case, reduce the speed setting on the program by referring to the maximum speeds shown in the table at the left.

Articulated robots
YA

Linear conveyor
modules
LCM100

Motor-less single
axis actuator
Robonity

Compact
single-axis robots
TRANSERVO

Single-axis robots
FLIP-X

Linear motor
single-axis robots
PHASER

Cartesian
robots
XY-X

SCARA
robots
YK-X

Pick & place
robots
YP-X

CLEAN

CONTROLLER

INFORMATION

Arm type

Gantry type

Moving arm
type

Pole type

XZ type

FXyBx 2 axes

- Arm type
- Cable carrier

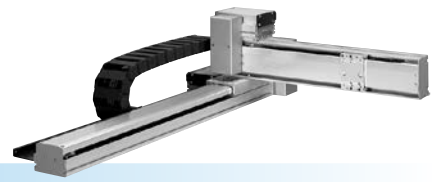

Ordering method

FXyBx - C

Model	Cable	Combination	X-axis stroke	Y-axis stroke	Cable
A1			15 to 245cm	15 to 55cm	3L: 3.5m
A2					5L: 5m
A3					10L: 10m
A4					

RCX320-2

Controller / Number of controllable axes	Safety standard	Option A (O.P.A)	Option B (O.P.B)	Vision System	Absolute battery
--	-----------------	------------------	------------------	---------------	------------------

Specify various controller setting items. **RCX320 ▶ P.548**

RCX222

Controller	Usable for CE	I/O selection 1	I/O selection 2
------------	---------------	-----------------	-----------------

Specify various controller setting items. **RCX222 ▶ P.558**

Specification

	X-axis	Y-axis
Axis construction <small>Note 1</small>	B10	-
AC servo motor output (W)	100	100
Repeatability <small>Note 2</small> (mm)	+/-0.04	+/-0.04
Drive system	Timing belt	Timing belt
Ball screw lead <small>Note 3</small> (Deceleration ratio) (mm)	Equivalent to lead 25	Equivalent to lead 25
Maximum speed (mm/sec)	1875	1875
Moving range (mm)	150 to 2450	150 to 550
Robot cable length (m)	Standard: 3.5 Option: 5,10	

Note 1. Use caution that the flame machining (installation holes, tap holes) differs from single-axis robots.
 Note 2. Positioning repeatability in one direction.
 Note 3. Leads not listed in the catalog are also available. Contact us for details.

Maximum payload (kg)

Y stroke (mm)	XY axes
150	7
250	6
350	5
450	5
550	3

Controller

Controller	Operation method
RCX320	Programming / I/O point trace / Remote command / Operation using RS-232C communication
RCX222	

FXyBx 2 axes (A1)

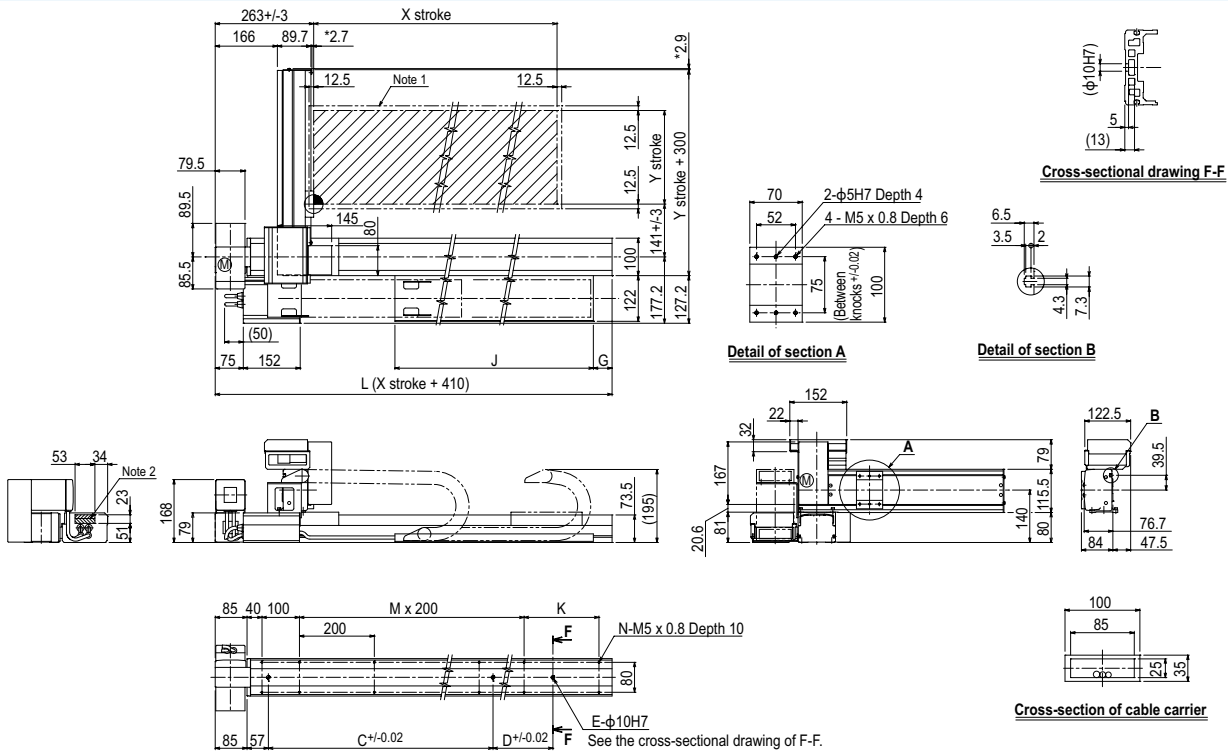

Note 1. The moving range when returning to origin and the stop position when stopping by the mechanical stopper.
 Note 2. The shaded position indicates an user cable extraction port.
 Note 3. The dimension marked with an asterisk (*) indicates the height of the screw.

X stroke	150	250	350	450	550	650	750	850	950	1050	1150	1250	1350	1450	1550	1650	1750	1850	1950	2050	2150	2250	2350	2450
L	560	660	760	860	960	1060	1160	1260	1360	1460	1560	1660	1760	1860	1960	2060	2160	2260	2360	2460	2560	2660	2760	2860
C	240	420	600	600	780	780	960	960	1140	1140	1320	1320	1320	1320	1320	1320	1320	1320	1320	1320	1320	1320	1320	1320
D	-	-	-	-	-	-	-	-	-	-	-	240	240	420	420	600	780	780	960	960	1140	1140	1140	1320
E	2	2	2	2	2	2	2	2	2	2	2	2	3	3	3	3	3	3	3	3	3	3	3	3
G	0	50	0	50	0	50	0	50	0	50	0	50	0	50	0	50	0	50	0	50	0	50	0	50
J	330	330	430	430	530	530	630	630	730	730	830	830	930	930	1030	1030	1130	1130	1230	1230	1330	1330	1430	1430
K	100	200	100	200	100	200	100	200	100	200	100	200	100	200	100	200	100	200	100	200	100	200	100	200
M	1	1	2	2	3	3	4	4	5	5	6	6	7	7	8	8	9	9	10	10	11	11	12	12
N	8	8	10	10	12	12	14	14	16	16	18	18	20	20	22	22	24	24	26	26	28	28	30	30
Y stroke	150	250	350	450	550																			

FXYBx 2 axes **A2**

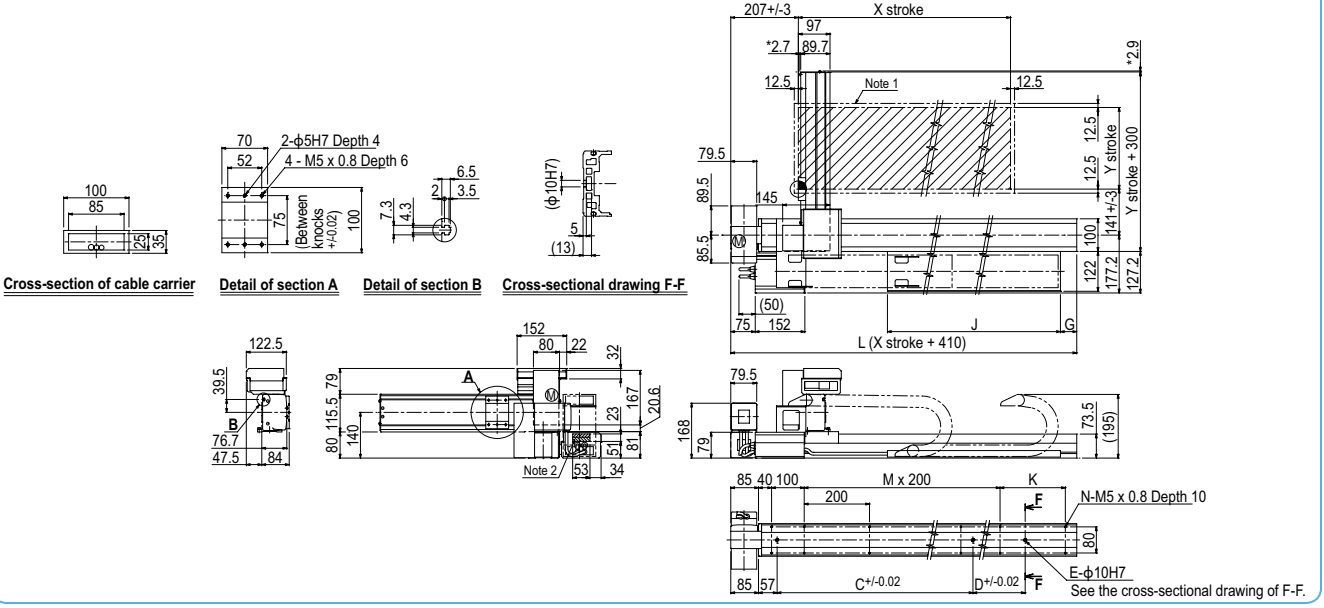

FXYBx 2 axes **A3**

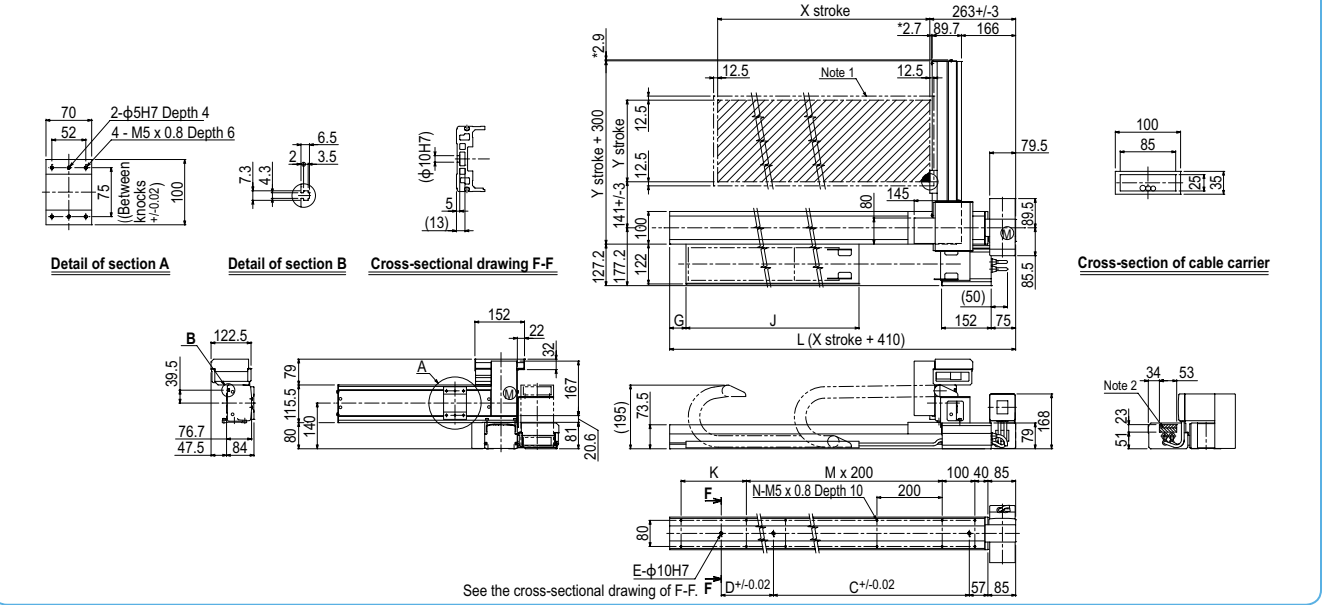

FXYBx 2 axes **A4**

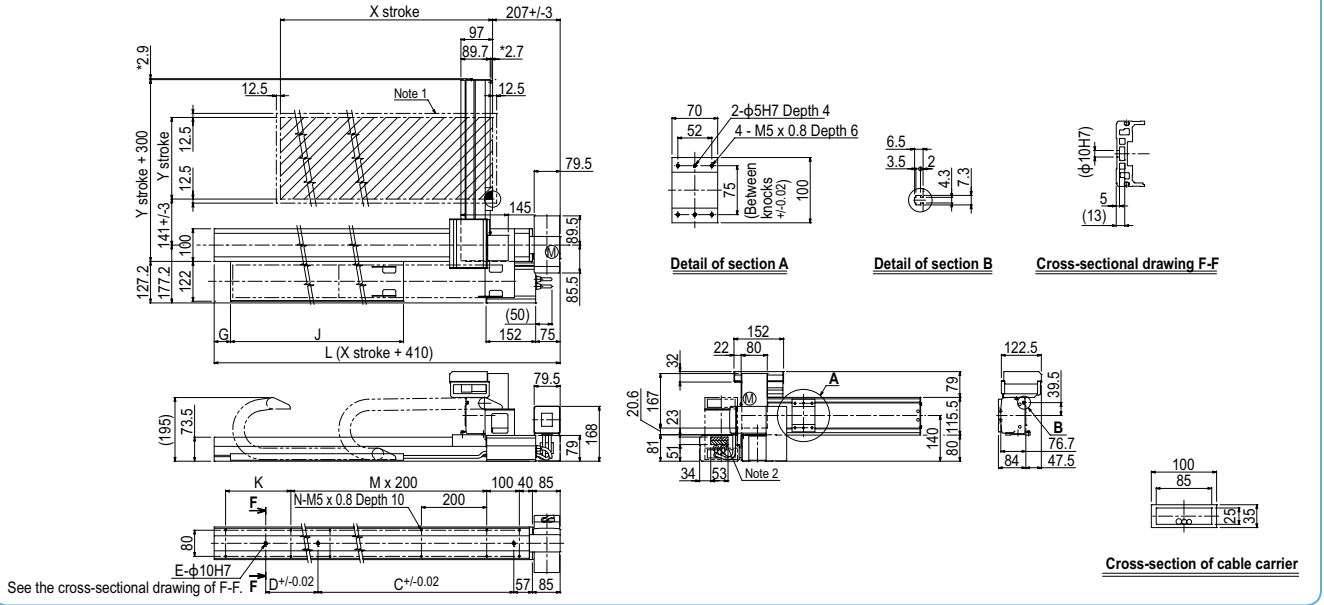

Articulated robots
YA
Linear conveyor modules
LCM100
Motor-less single axis actuator
Robonity
Compact single-axis robots
TRANSEVO
Single-axis robots
FLIP-X
Linear motor single-axis robots
PHASER
Cartesian robots
XY-X
SCARA robots
YK-X
Pick & place robots
YP-X
CLEAN
CONTROLLER INFORMATION
Arm type
Gantry type
Moving arm type
Pole type
XZ type

FXyBx 2 axes

● Arm type ● Whipover

Ordering method

FXyBx - S

Model	Cable	Combination	X-axis stroke	Y-axis stroke	Cable
A1			15 to 95cm	15 to 55cm	3L: 3.5m
A2					5L: 5m
A3					10L: 10m
A4					

RCX320-2

Controller / Number of controllable axes	Safety standard	Option A (OP.A)	Option B (OP.B)	Vision System	Absolute battery

Specify various controller setting items. RCX320 ▶ P.548

RCX222

Controller	Usable for CE	I/O selection 1	I/O selection 2

Specify various controller setting items. RCX222 ▶ P.558

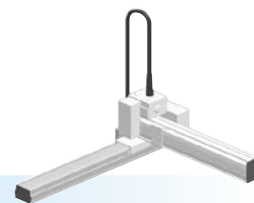

Specification

	X-axis	Y-axis
Axis construction ^{Note 1}	B10	-
AC servo motor output (W)	100	100
Repeatability ^{Note 2} (mm)	+/-0.04	+/-0.04
Drive system	Timing belt	Timing belt
Ball screw lead ^{Note 3} (Deceleration ratio) (mm)	Equivalent to lead 25	Equivalent to lead 25
Maximum speed (mm/sec)	1875	1875
Moving range (mm)	150 to 950	150 to 550
Robot cable length (m)	Standard: 3.5 Option: 5,10	

Note 1. Use caution that the flame machining (installation holes, tap holes) differs from single-axis robots.
 Note 2. Positioning repeatability in one direction.
 Note 3. Leads not listed in the catalog are also available. Contact us for details.

Maximum payload (kg)

Y stroke (mm)	XY 2 axes
150	7
250	6
350	5
450	5
550	3

Controller

Controller	Operation method
RCX320	Programming / I/O point trace / Remote command / Operation using RS-232C communication
RCX222	

FXyBx 2 axes A1

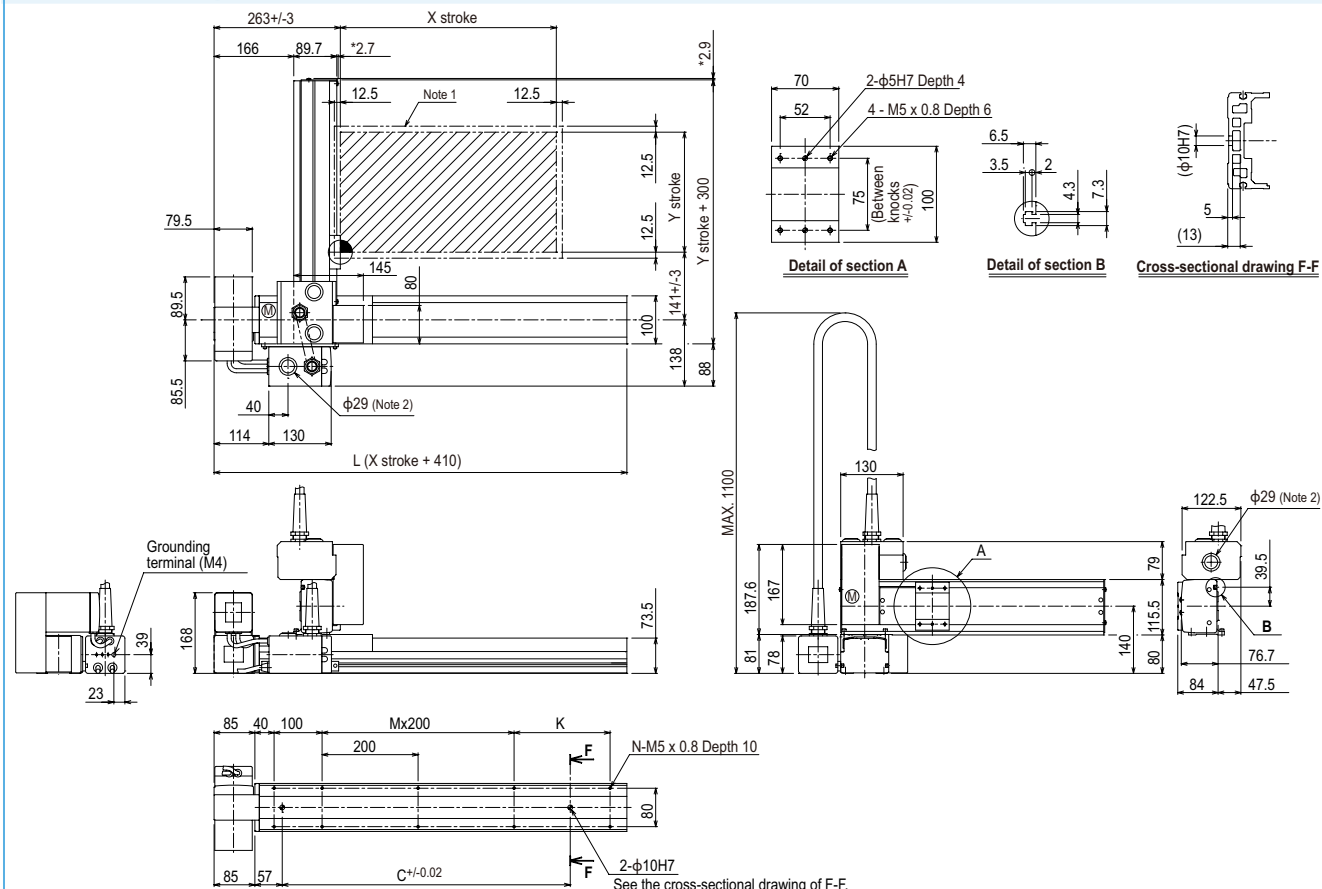

X stroke	150	250	350	450	550	650	750	850	950
L	560	660	760	860	960	1060	1160	1260	1360
C	240	420	600	600	780	780	960	960	1140
K	100	200	100	200	100	200	100	200	100
M	1	1	2	2	3	3	4	4	5
N	8	8	10	10	12	12	14	14	16
Y stroke	150	250	350	450	550				

Note 1. The moving range when returning to origin and the stop position when stopping by the mechanical stopper.
 Note 2. User cable extraction port.
 Note 3. The dimension marked with an asterisk (*) indicates the height of the screw.

FXYBx 2 axes A2

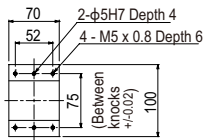

Detail of section A

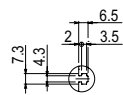

Detail of section B

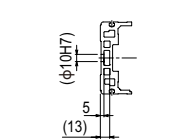

Cross-sectional drawing F-F

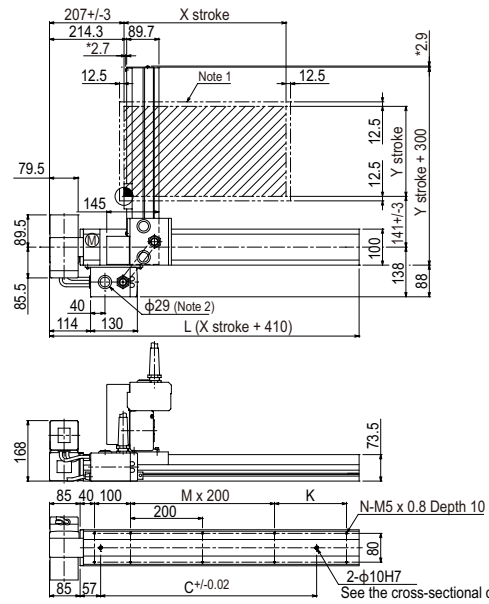
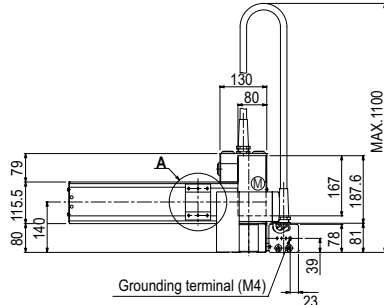
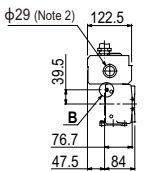

FXYBx 2 axes A3

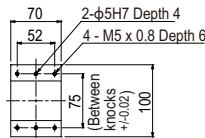

Detail of section A

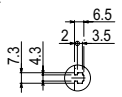

Detail of section B

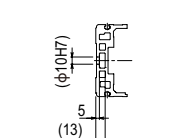

Cross-sectional drawing F-F

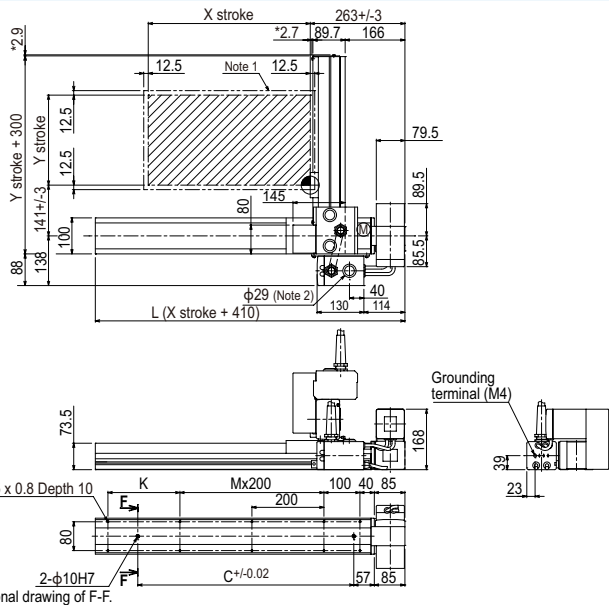
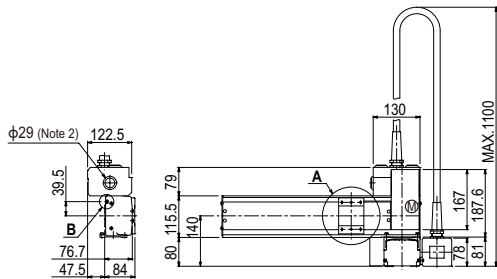

See the cross-sectional drawing of F-F.

FXYBx 2 axes A4

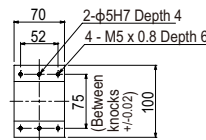
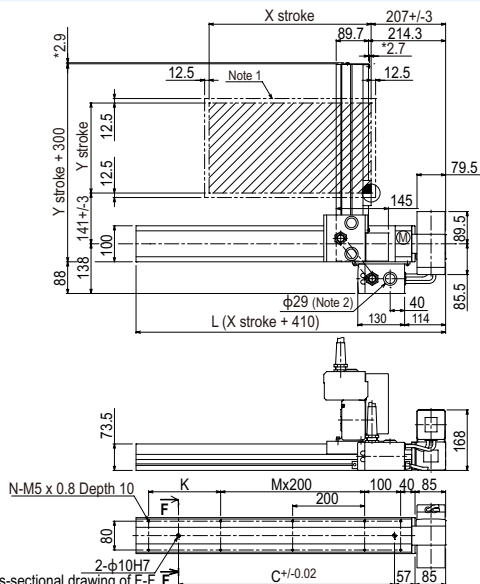

Detail of section A

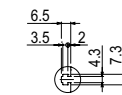

Detail of section B

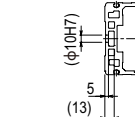

Cross-sectional drawing F-F

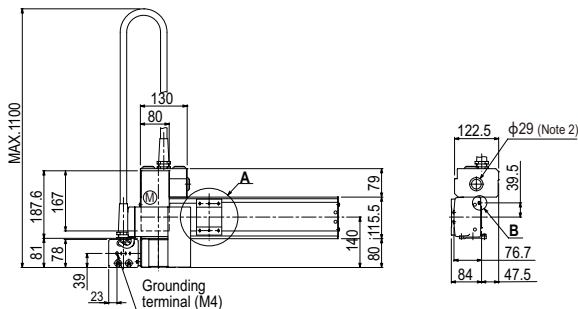

See the cross-sectional drawing of F-F.

- Articulated robots
- YA
- Linear conveyor modules
- LCM100
- Motor-less single axis actuator
- Robonity
- Compact single-axis robots
- TRANSEVO
- Single-axis robots
- FLIP-X
- Linear motor single-axis robots
- PHASER
- Cartesian robots
- XX-X
- SCARA robots
- YK-X
- Pick & place robots
- YP-X
- CLEAN
- CONTROLLER
- INFORMATION
- Arm type
- Gantry type
- Moving arm type
- Pole type
- XZ type

FXyBx 2 axes / IO

- Arm type
- Cable carrier
- Type with Y-axis I/O cable carrier added

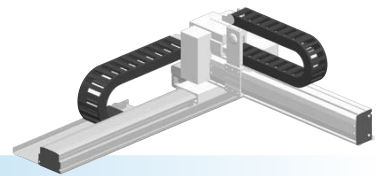

Ordering method

FXyBx - C				IO		
Model	Cable	Combination	X-axis stroke	Y-axis stroke	ZR-axis	Cable
A1			15 to 245cm	15 to 55cm		3L: 3.5m
A2						5L: 5m
A3						10L: 10m
A4						

RCX320-2					
Controller / Number of controllable axes	Safety standard	Option A (OP.A)	Option B (OP.B)	Vision System	Absolute battery
Specify various controller setting items. RCX320 ▶ P.548					

RCX222			
Controller	Usable for CE	I/O selection 1	I/O selection 2
Specify various controller setting items. RCX222 ▶ P.558			

Specification

	X-axis	Y-axis
Axis construction ^{Note 1}	B10	-
AC servo motor output (W)	100	100
Repeatability ^{Note 2} (mm)	+/-0.04	+/-0.04
Drive system	Timing belt	Timing belt
Ball screw lead ^{Note 3} (Deceleration ratio) (mm)	Equivalent to lead 25	Equivalent to lead 25
Maximum speed (mm/sec)	1875	1875
Moving range (mm)	150 to 2450	150 to 550
Robot cable length (m)	Standard: 3.5 Option: 5,10	

Note 1. Use caution that the flame machining (installation holes, tap holes) differs from single-axis robots.
 Note 2. Positioning repeatability in one direction.
 Note 3. Leads not listed in the catalog are also available. Contact us for details.

Maximum payload (kg)

Y stroke (mm)	XY 2 axes
150	7
250	6
350	5
450	5
550	3

Controller

Controller	Operation method
RCX320	Programming / I/O point trace / Remote command / Operation using RS-232C communication
RCX222	

FXyBx 2 axes / IO (A1)

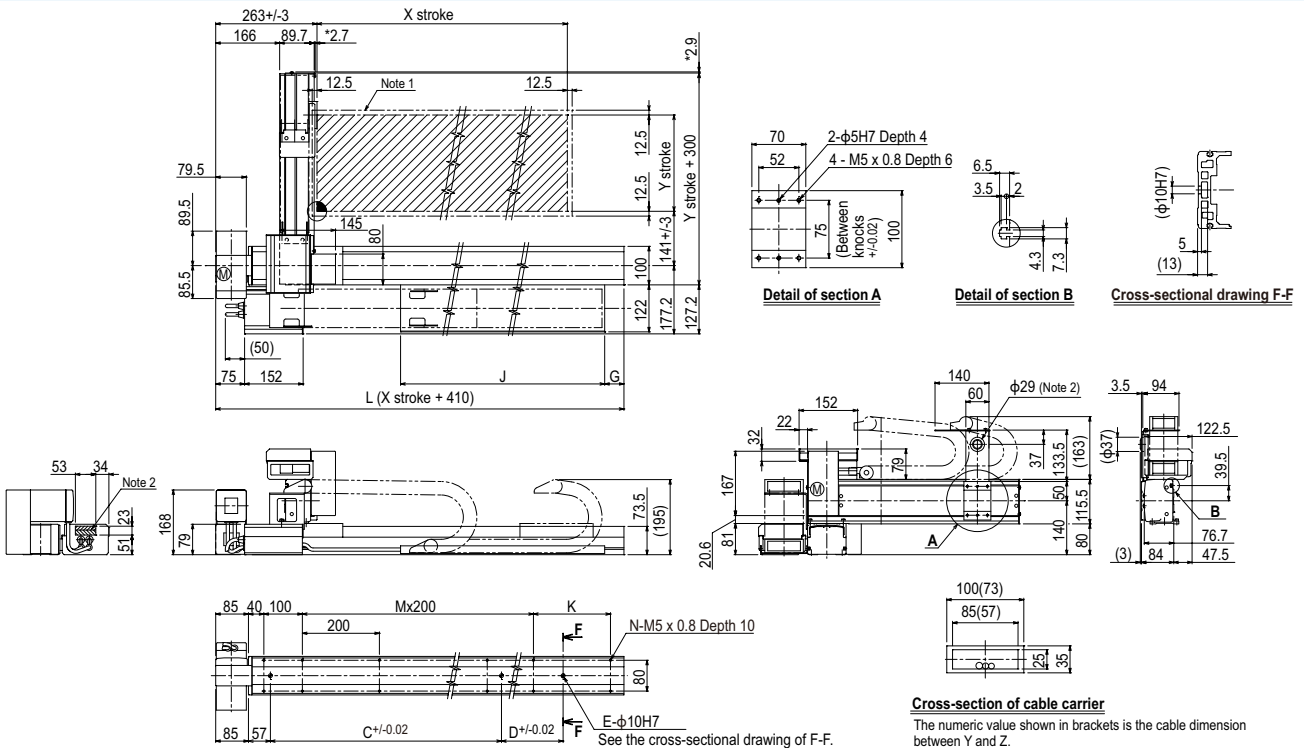

Note 1. The moving range when returning to origin and the stop position when stopping by the mechanical stopper. Note 3. The dimension marked with an asterisk (*) indicates the height of the screw.
 Note 2. The shaded position indicates an user cable extraction port.

X stroke	150	250	350	450	550	650	750	850	950	1050	1150	1250	1350	1450	1550	1650	1750	1850	1950	2050	2150	2250	2350	2450
L	560	660	760	860	960	1060	1160	1260	1360	1460	1560	1660	1760	1860	1960	2060	2160	2260	2360	2460	2560	2660	2760	2860
C	240	420	600	600	780	780	960	960	1140	1140	1320	1320	1320	1320	1320	1320	1320	1320	1320	1320	1320	1320	1320	1320
D	-	-	-	-	-	-	-	-	-	-	-	240	240	420	420	600	780	780	960	960	1140	1140	1320	1320
E	2	2	2	2	2	2	2	2	2	2	2	2	3	3	3	3	3	3	3	3	3	3	3	3
G	0	50	0	50	0	50	0	50	0	50	0	50	0	50	0	50	0	50	0	50	0	50	0	50
J	330	330	430	430	530	530	630	630	730	730	830	830	930	930	1030	1030	1130	1130	1230	1230	1330	1330	1430	1430
K	100	200	100	200	100	200	100	200	100	200	100	200	100	200	100	200	100	200	100	200	100	200	100	200
M	1	1	2	2	3	3	4	4	5	5	6	6	7	7	8	8	9	9	10	10	11	11	12	12
N	8	8	10	10	12	12	14	14	16	16	18	18	20	20	22	22	24	24	26	26	28	28	30	30
Y stroke	150	250	350	450	550																			

Articulated robots
YA

Linear conveyor
modules
LCM100

Motor-less single
axis actuator
Robonity

Compact
single-axis robots
TRANSERVO

Single-axis robots
FLIP-X

Linear motor
single-axis robots
PHASER

Cartesian
robots
XY-X

SCARA
robots
YK-X

Pick & place
robots
YP-X

CLEAN

CONTROLLER

INFORMATION

Arm type

Gantry type

Moving arm
type

Pole type

XZ type

SXYx 2 axes

● Arm type ● Cable carrier

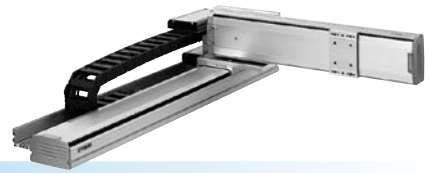

Ordering method

SXYx - C

Model	Cable	Combination	X-axis stroke	Y-axis stroke	Cable
A1			15 to 105cm	15 to 65cm	3L: 3.5m
A2					5L: 5m
A3					10L: 10m
A4					

RCX320-2

Controller / Number of controllable axes	Safety standard	Option A (OP.A)	Option B (OP.B)	Vision System	Absolute battery

Specify various controller setting items. RCX320 ▶ P.548

RCX222

Controller	Usable for CE	I/O selection 1	I/O selection 2

Specify various controller setting items. RCX222 ▶ P.558

Specification

	X-axis	Y-axis
Axis construction ^{Note 1}	F14H	F14
AC servo motor output (W)	200	100
Repeatability ^{Note 2} (mm)	+/-0.01	+/-0.01
Drive system	Ball screw φ15	Ball screw φ15
Ball screw lead ^{Note 3} (Deceleration ratio) (mm)	20	20
Maximum speed ^{Note 4} (mm/sec)	1200	1200
Moving range (mm)	150 to 1050	150 to 650
Robot cable length (m)	Standard: 3.5 Option: 5,10	

Note 1. Use caution that the flange machining (installation holes, tap holes) differs from single-axis robots.
 Note 2. Positioning repeatability in one direction.
 Note 3. Leads not listed in the catalog are also available. Contact us for details.
 Note 4. When the X-axis stroke is longer than 750mm, resonance of the ball screw may occur depending on the operation conditions (critical speed). In this case, reduce the speed setting on the program by referring to the maximum speeds shown in the table below.

Maximum payload (kg)

Y stroke (mm)	XY 2 axes
150	20
250	17
350	15
450	13
550	11
650	9

Controller

Controller	Operation method
RCX320	Programming / I/O point trace / Remote command / Operation using RS-232C communication
RCX222	

SXYx 2 axes A1

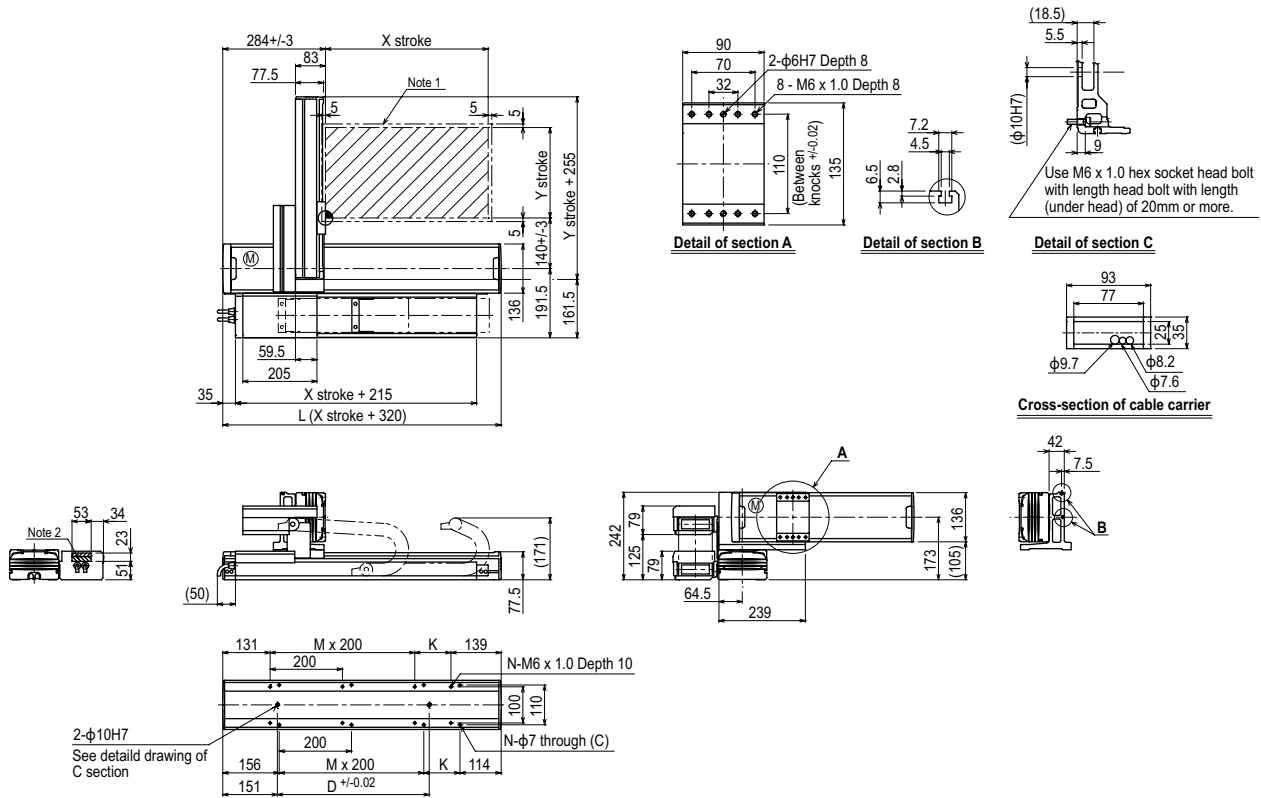

X stroke	Y stroke										
	150	250	350	450	550	650	750	850	950	1050	
L	470	570	670	770	870	970	1070	1170	1270	1370	
K	200	100	200	100	200	100	200	100	200	100	
D	240	240	420	420	600	600	780	960	960	1140	
M	0	1	1	2	2	3	3	4	4	5	
N	4	6	6	8	8	10	10	12	12	14	
Y stroke	150	250	350	450	550	650					
Maximum speed for each stroke (mm/sec) ^{Note 3}	X-axis	1200					960	780	600	540	
	Speed setting	-					80%	65%	50%	45%	

Note 1. The moving range when returning to origin and the stop position when stopping by the mechanical stopper.
 Note 2. The shaded position indicates a user cable extraction port.

Note 3. When the X-axis stroke is longer than 750mm, resonance of the ball screw may occur depending on the operation conditions (critical speed). In this case, reduce the speed setting on the program by referring to the maximum speeds shown in the table at the left.

SXYx 2 axes **A2**

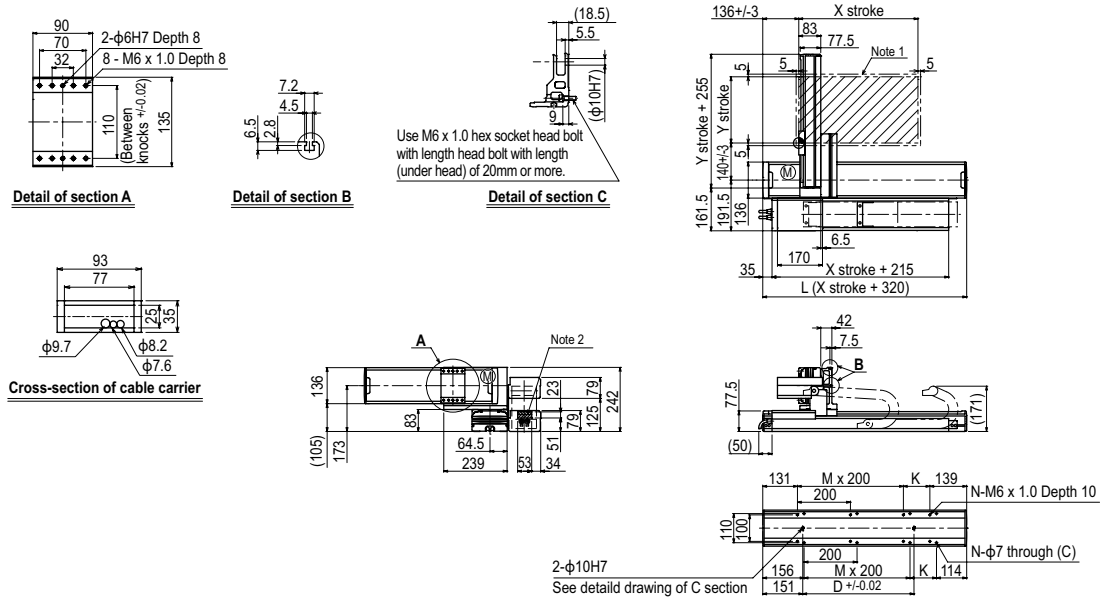

SXYx 2 axes **A3**

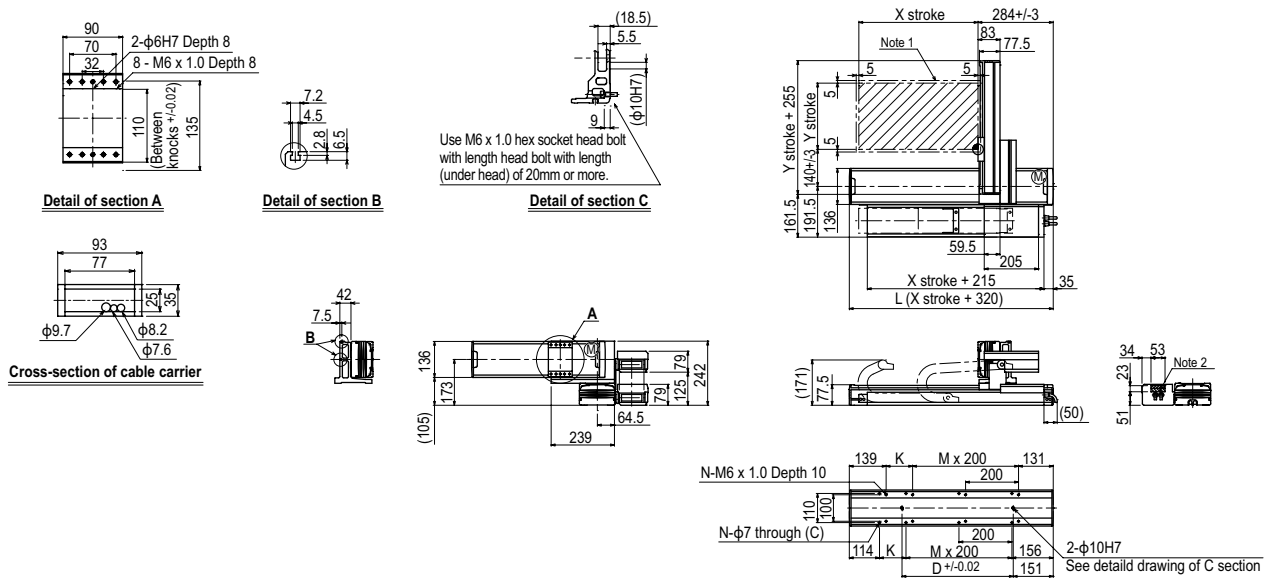

SXYx 2 axes **A4**

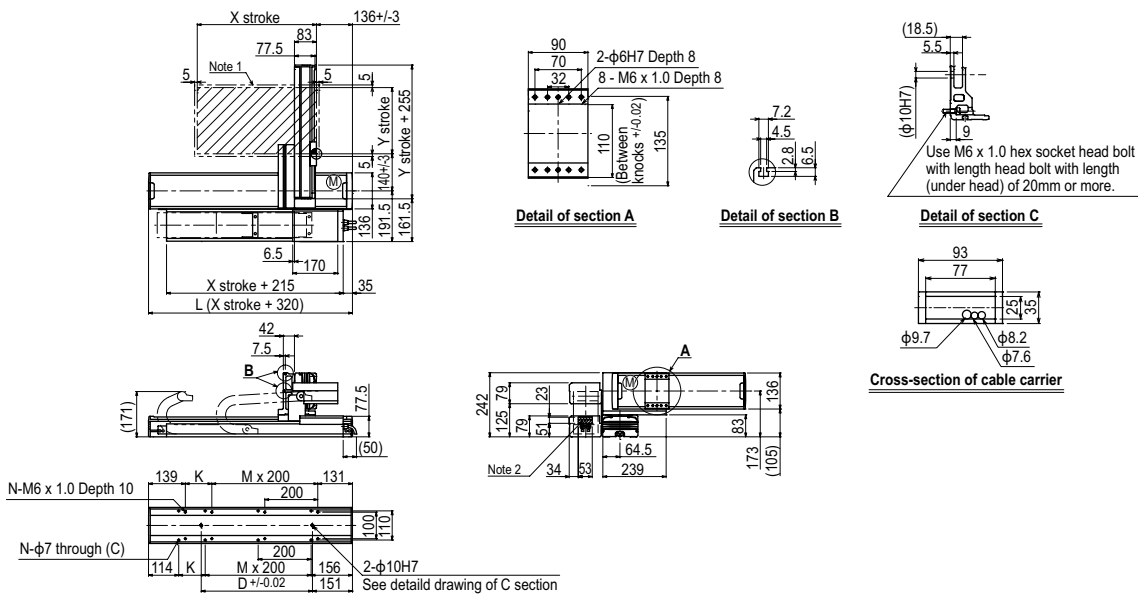

Articulated robots
YA
Linear conveyor modules
LCM100
Motor-less single axis actuator
Robonity
Compact single-axis robots
TRANSEVO
Single-axis robots
FLIP-X
Linear motor single-axis robots
PHASER
Cartesian robots
XY-X
SCARA robots
YK-X
Pick & place robots
YP-X
CLEAN
CONTROLLER
INFORMATION
Arm type
Gantry type
Moving arm type
Pole type
XZ type

SXYx 2 axes

● Arm type ● Whipover

Ordering method

SXYx - S

Model	Cable	Combination	X-axis stroke	Y-axis stroke	Cable
A1			15 to 85cm	15 to 65cm	3L: 3.5m
A2					5L: 5m
A3					10L: 10m
A4					

RCX320-2

Controller / Number of controllable axes	Safety standard	Option A (OP.A)	Option B (OP.B)	Vision System	Absolute battery

Specify various controller setting items. RCX320 ▶ **P.548**

RCX222

Controller	Usable for CE	I/O selection 1	I/O selection 2

Specify various controller setting items. RCX222 ▶ **P.558**

Specification

	X-axis	Y-axis
Axis construction ^{Note 1}	F14H	F14
AC servo motor output (W)	200	100
Repeatability ^{Note 2} (mm)	+/-0.01	+/-0.01
Drive system	Ball screw φ15	Ball screw φ15
Ball screw lead ^{Note 3} (Deceleration ratio) (mm)	20	20
Maximum speed ^{Note 4} (mm/sec)	1200	1200
Moving range (mm)	150 to 850	150 to 650
Robot cable length (m)	Standard: 3.5 Option: 5,10	

Note 1. Use caution that the flame machining (installation holes, tap holes) differs from single-axis robots.
 Note 2. Positioning repeatability in one direction.
 Note 3. Leads not listed in the catalog are also available. Contact us for details.
 Note 4. When the X-axis stroke is longer than 750mm, resonance of the ball screw may occur depending on the operation conditions (critical speed). In this case, reduce the speed setting on the program by referring to the maximum speeds shown in the table below.

Maximum payload (kg)

Y stroke (mm)	XY 2 axes
150	20
250	17
350	15
450	13
550	11
650	9

Controller

Controller	Operation method
RCX320	Programming / I/O point trace / Remote command / Operation using RS-232C communication
RCX222	

SXYx 2 axes A1

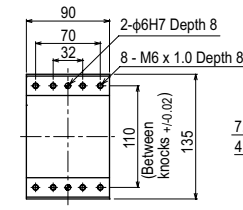
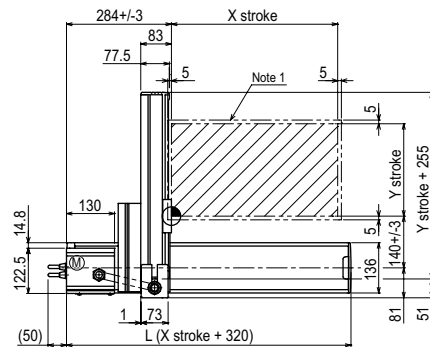

Detail section A

Detail section B

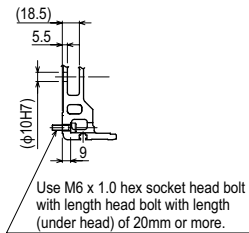

Detail section C

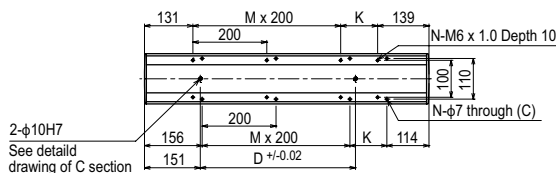
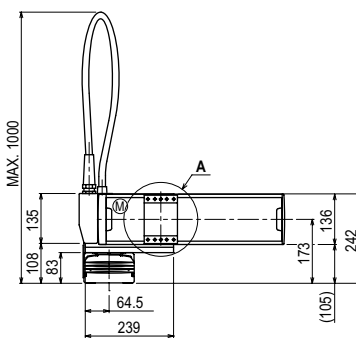
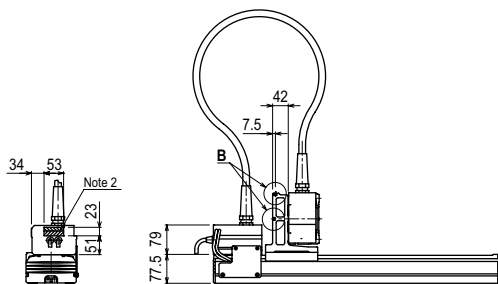

X stroke	150	250	350	450	550	650	750	850
L	470	570	670	770	870	970	1070	1170
K	200	100	200	100	200	100	200	100
D	240	240	420	420	600	600	780	960
M	0	1	1	2	2	3	3	4
N	4	6	6	8	8	10	10	12
Y stroke	150	250	350	450	550	650		
Maximum speed for each stroke (mm/sec) ^{Note 3}	X-axis		1200		960		780	
	Speed setting		-		80%		65%	

Note 1. The moving range when returning to origin and the stop position when stopping by the mechanical stopper.
 Note 2. The shaded position indicates a user cable extraction port.

Note 3. When the X-axis stroke is longer than 750mm, resonance of the ball screw may occur depending on the operation conditions (critical speed). In this case, reduce the speed setting on the program by referring to the maximum speeds shown in the table at the left.

SXYx 2 axes **A2**

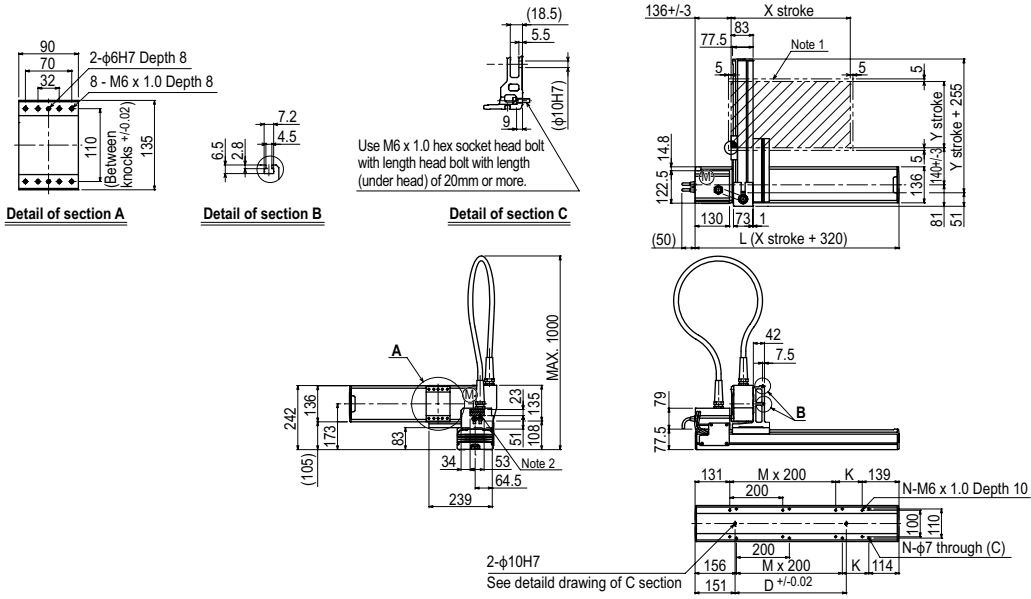

SXYx 2 axes **A3**

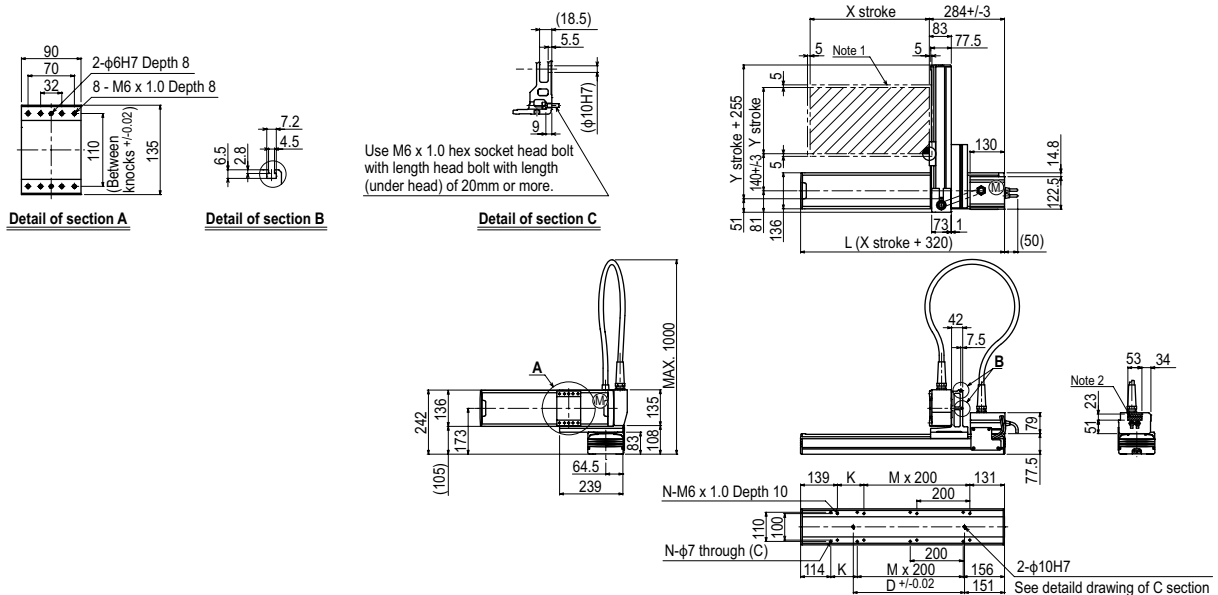

SXYx 2 axes **A4**

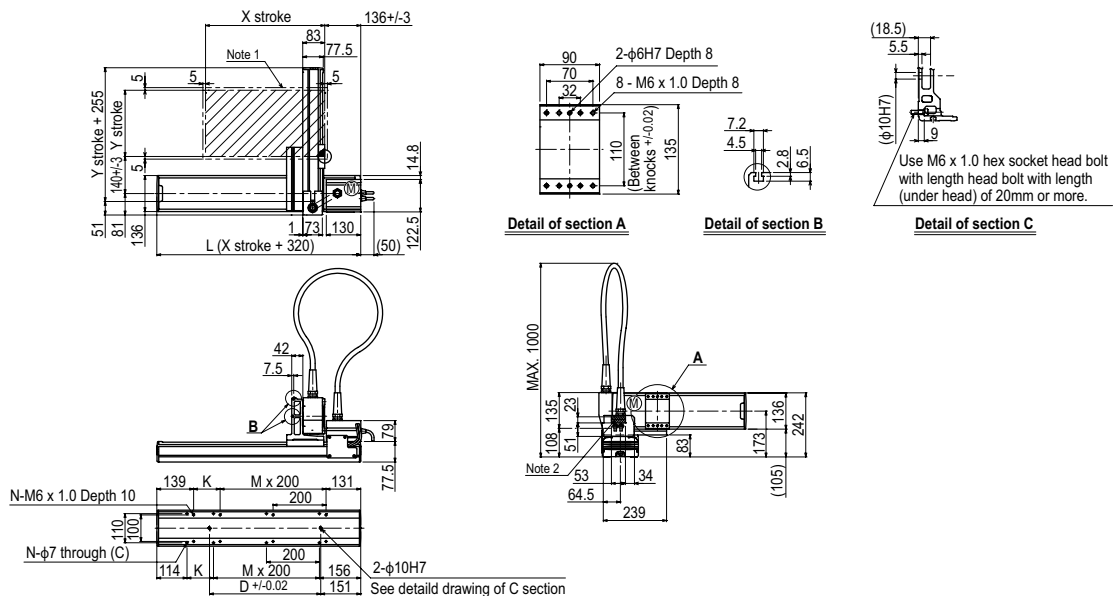

Articulated robots
YA
 Linear conveyor modules
LCM100
 Motor-less single axis actuator
Robonity
 Compact single-axis robots
TRANSEVO
 Single-axis robots
FLIP-X
 Linear motor single-axis robots
PHASER
 Cartesian robots
XY-X
 SCARA robots
YK-X
 Pick & place robots
YP-X
 CLEAN
 CONTROLLER
 INFORMATION
 Arm type
 Gantry type
 Moving arm type
 Pole type
 XZ type

SXYx 2 axes / IO

● Arm type ● Cable carrier

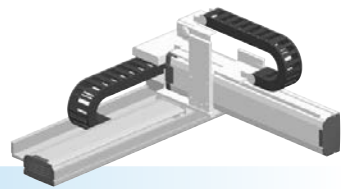

Ordering method

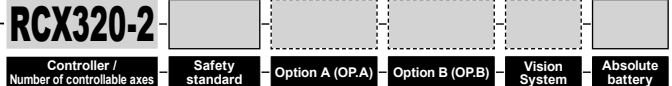
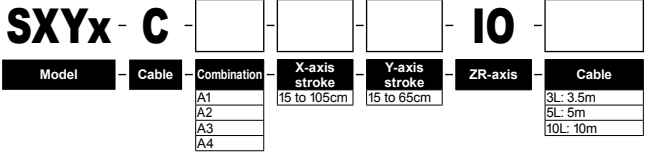

Specify various controller setting items. RCX320 ▶ P.548

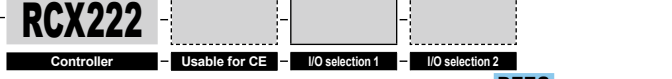

Specify various controller setting items. RCX222 ▶ P.558

Specification

	X-axis	Y-axis
Axis construction <small>Note 1</small>	F14H	F14
AC servo motor output (W)	200	100
Repeatability <small>Note 2</small> (mm)	+/-0.01	+/-0.01
Drive system	Ball screw φ15	Ball screw φ15
Ball screw lead <small>Note 3</small> (Deceleration ratio) (mm)	20	20
Maximum speed <small>Note 4</small> (mm/sec)	1200	1200
Moving range (mm)	150 to 1050	150 to 650
Robot cable length (m)	Standard: 3.5 Option: 5, 10	

Note 1. Use caution that the flame machining (installation holes, tap holes) differs from single-axis robots.
 Note 2. Positioning repeatability in one direction.
 Note 3. Leads not listed in the catalog are also available. Contact us for details.
 Note 4. When the X-axis stroke is longer than 750mm, resonance of the ball screw may occur depending on the operation conditions (critical speed). In this case, reduce the speed setting on the program by referring to the maximum speeds shown in the table below.

Maximum payload (kg)

Y stroke (mm)	XY 2 axes
150	19
250	16
350	14
450	12
550	10
650	8

Controller

Controller	Operation method
RCX320	Programming / I/O point trace / Remote command / Operation using RS-232C communication
RCX222	

SXYx 2 axes / IO A1

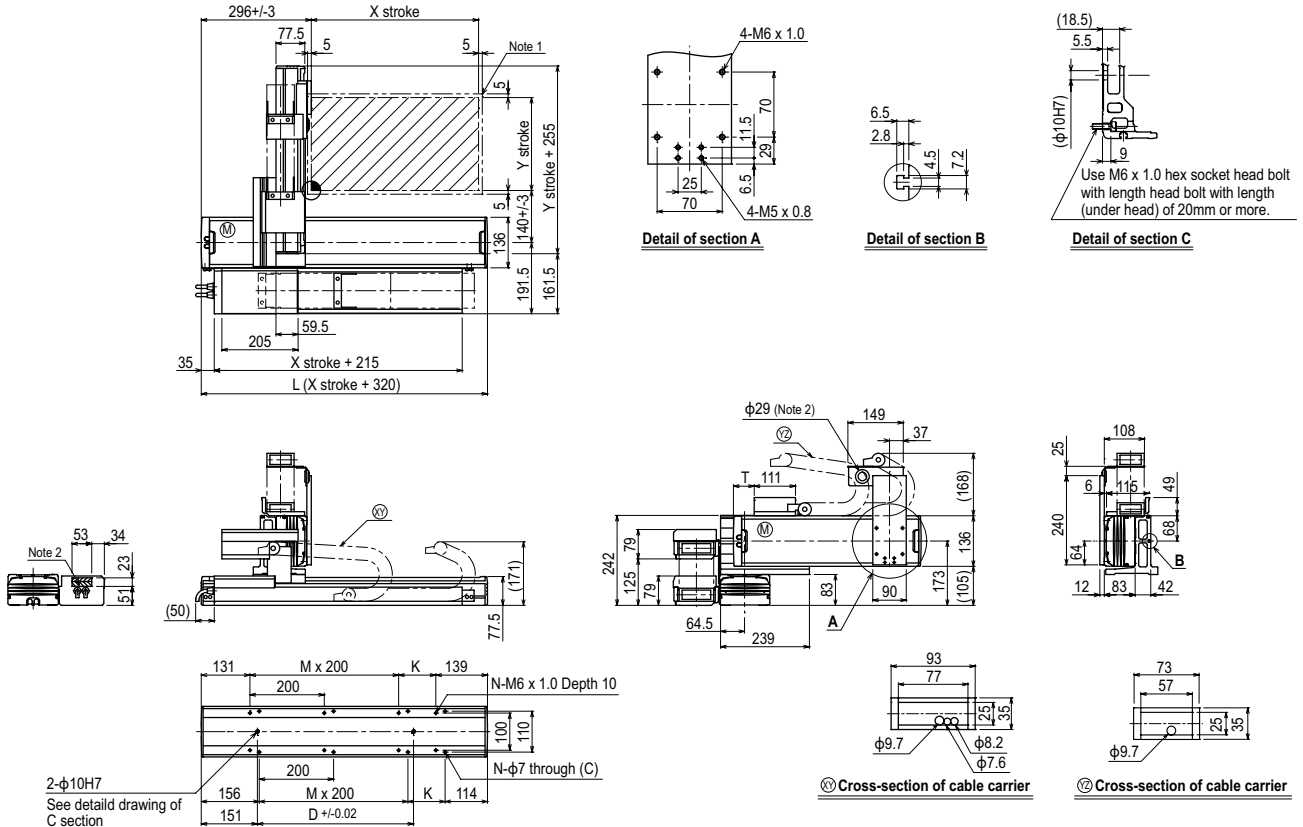

X stroke	150	250	350	450	550	650	750	850	950	1050
L	470	570	670	770	870	970	1070	1170	1270	1370
K	200	100	200	100	200	100	200	100	200	100
D	240	240	420	420	600	600	780	960	960	1140
M	0	1	1	2	2	3	3	4	4	5
N	4	6	6	8	8	10	10	12	12	14
Y stroke	150	250	350	450	550	650				
T	55	110	165	220	275	330				

Note 1. The moving range when returning to origin and the stop position when stopping by the mechanical stopper.
 Note 2. The shaded position indicates a user cable extraction port.

Note 3. When the X-axis stroke is longer than 750mm, resonance of the ball screw may occur depending on the operation conditions (critical speed). In this case, reduce the speed setting on the program by referring to the maximum speeds shown in the table at the left.

Maximum speed for each stroke (mm/sec)	X-axis	1200	960	780	600	540
Speed setting		-	80%	65%	50%	45%

Articulated robots
YA

Linear conveyor
modules
LCM100

Motor-less single
axis actuator
Robonity

Compact
single-axis robots
TRANSERVO

Single-axis robots
FLIP-X

Linear motor
single-axis robots
PHASER

Cartesian
robots
XY-X

SCARA
robots
YK-X

Pick & place
robots
YP-X

CLEAN

CONTROLLER

INFORMATION

Arm type

Gantry type

Moving arm
type

Pole type

XZ type

SXYx 3 axes / ZF

- Arm type
- Cable carrier
- Z-axis: clamped base / moving table type (100W)



Ordering method

SXYx - C [] [] [] - **ZF** [] [] - **RCX340-3** [] [] [] [] [] [] [] [] [] [] [] []

Model	Cable	Combination	X-axis stroke	Y-axis stroke	ZR-axis	Z-axis stroke	Cable	Controller / Number of controllable axes	Safety standard	Option A (OP.A)	Option B (OP.B)	Option C (OP.C)	Option D (OP.D)	Option E (OP.E)	Absolute battery
A1		A1	15 to 105cm	15 to 65cm		15 to 35cm	3L: 3.5m 5L: 5m 10L: 10m								

Specify various controller setting items. RCX340 ▶ **P.566**

Specification

	X-axis	Y-axis	Z-axis
Axis construction <small>Note 1</small>	F14H	F14	F10-BK
AC servo motor output (W)	200	100	100
Repeatability <small>Note 2</small> (mm)	+/-0.01	+/-0.01	+/-0.01
Drive system	Ball screw ϕ 15	Ball screw ϕ 15	Ball screw ϕ 15
Ball screw lead <small>Note 3</small> (Deceleration ratio) (mm)	20	20	10
Maximum speed <small>Note 4</small> (mm/sec)	1200	1200	600
Moving range (mm)	150 to 1050	150 to 650	150 to 350
Robot cable length (m)	Standard: 3.5 Option: 5,10		

- Note 1. Use caution that the flame machining (installation holes, tap holes) differs from single-axis robots.
 Note 2. Positioning repeatability in one direction.
 Note 3. Leads not listed in the catalog are also available. Contact us for details.
 Note 4. When the X-axis stroke is longer than 750mm, resonance of the ball screw may occur depending on the operation conditions (critical speed). In this case, reduce the speed setting on the program by referring to the maximum speeds shown in the table below.

Maximum payload (kg)

Y stroke (mm)	Z stroke (mm)		
	150	250	350
150	10	10	10
250	10	10	9
350	9	8	7
450	7	6	5
550	5	4	3
650	3	2	1

Controller

Controller	Operation method
RCX340	Programming / I/O point trace / Remote command / Operation using RS-232C communication

SXYx 3 axes / ZF A1

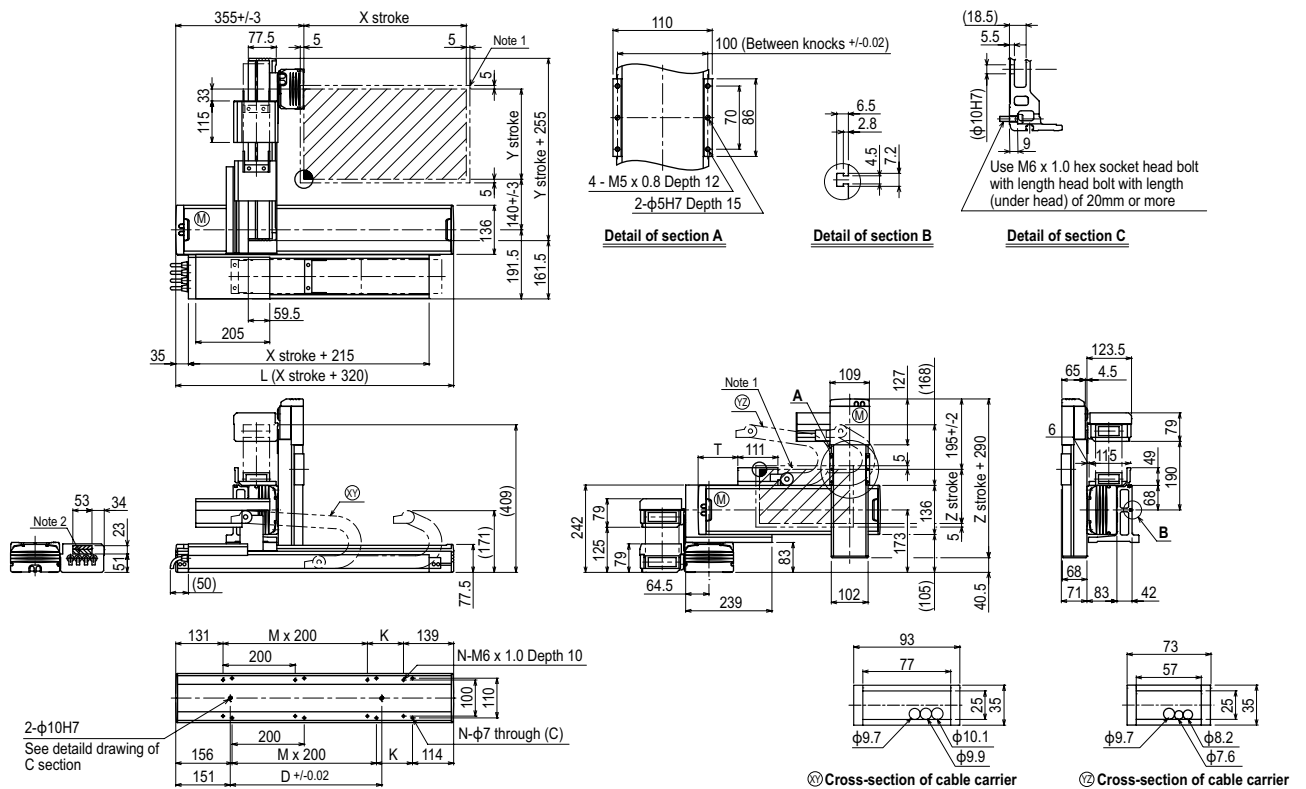

X stroke	150	250	350	450	550	650	750	850	950	1050
L	470	570	670	770	870	970	1070	1170	1270	1370
K	200	100	200	100	200	100	200	100	200	100
D	240	240	420	420	600	600	780	960	960	1140
M	0	1	1	2	2	3	3	3	4	5
N	4	6	6	8	8	10	10	12	12	14
Y stroke	150	250	350	450	550	650				
T	55	110	165	220	275	330				
Z stroke	150	250	350							
Maximum speed for each stroke (mm/sec) <small>Note 3</small>	X-axis		1200			960		780	600	540
Speed setting			-			80%		65%	50%	45%

- Note 1. The moving range when returning to origin and the stop position when stopping by the mechanical stopper.
 Note 2. The shaded position indicates a user cable extraction port.

- Note 3. When the X-axis stroke is longer than 750mm, resonance of the ball screw may occur depending on the operation conditions (critical speed). In this case, reduce the speed setting on the program by referring to the maximum speeds shown in the table at the left.

SXYx

3 axes / ZF

- Arm type
- Whipover
- Z-axis: clamped base / moving table type (100W)

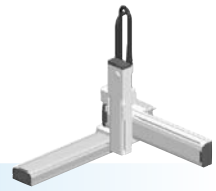

Ordering method

SXYx - S [] [] [] **ZF** [] [] **RCX340-3** [] [] [] [] [] [] [] [] [] []

Model	Cable	Combination	X-axis stroke	Y-axis stroke	ZR-axis	Z-axis stroke	Cable	Controller / Number of controllable axes	Safety standard	Option A (OP.A)	Option B (OP.B)	Option C (OP.C)	Option D (OP.D)	Option E (OP.E)	Absolute battery
A1			15 to 85cm	15 to 65cm		15 to 35cm	3L: 3.5m 5L: 5m 10L: 10m								

Specify various controller setting items. RCX340 ▶ **P.566**

Specification

	X-axis	Y-axis	Z-axis
Axis construction ^{Note 1}	F14H	F14	F10-BK
AC servo motor output (W)	200	100	100
Repeatability ^{Note 2} (mm)	+/-0.01	+/-0.01	+/-0.01
Drive system	Ball screw φ15	Ball screw φ15	Ball screw φ15
Ball screw lead ^{Note 3} (Deceleration ratio) (mm)	20	20	10
Maximum speed ^{Note 4} (mm/sec)	1200	1200	600
Moving range (mm)	150 to 850	150 to 650	150 to 350
Robot cable length (m)	Standard: 3.5 Option: 5,10		

- Note 1. Use caution that the flange machining (installation holes, tap holes) differs from single-axis robots.
 Note 2. Positioning repeatability in one direction.
 Note 3. Leads not listed in the catalog are also available. Contact us for details.
 Note 4. When the X-axis stroke is longer than 750mm, resonance of the ball screw may occur depending on the operation conditions (critical speed). In this case, reduce the speed setting on the program by referring to the maximum speeds shown in the table below.

Maximum payload (kg)

Y stroke (mm)	Z stroke (mm)		
	150	250	350
150	10	10	10
250	10	10	9
350	9	8	7
450	7	6	5
550	5	4	3
650	3	2	1

Controller

Controller	Operation method
RCX340	Programming / I/O point trace / Remote command / Operation using RS-232C communication

SXYx 3 axes / ZF (A1)

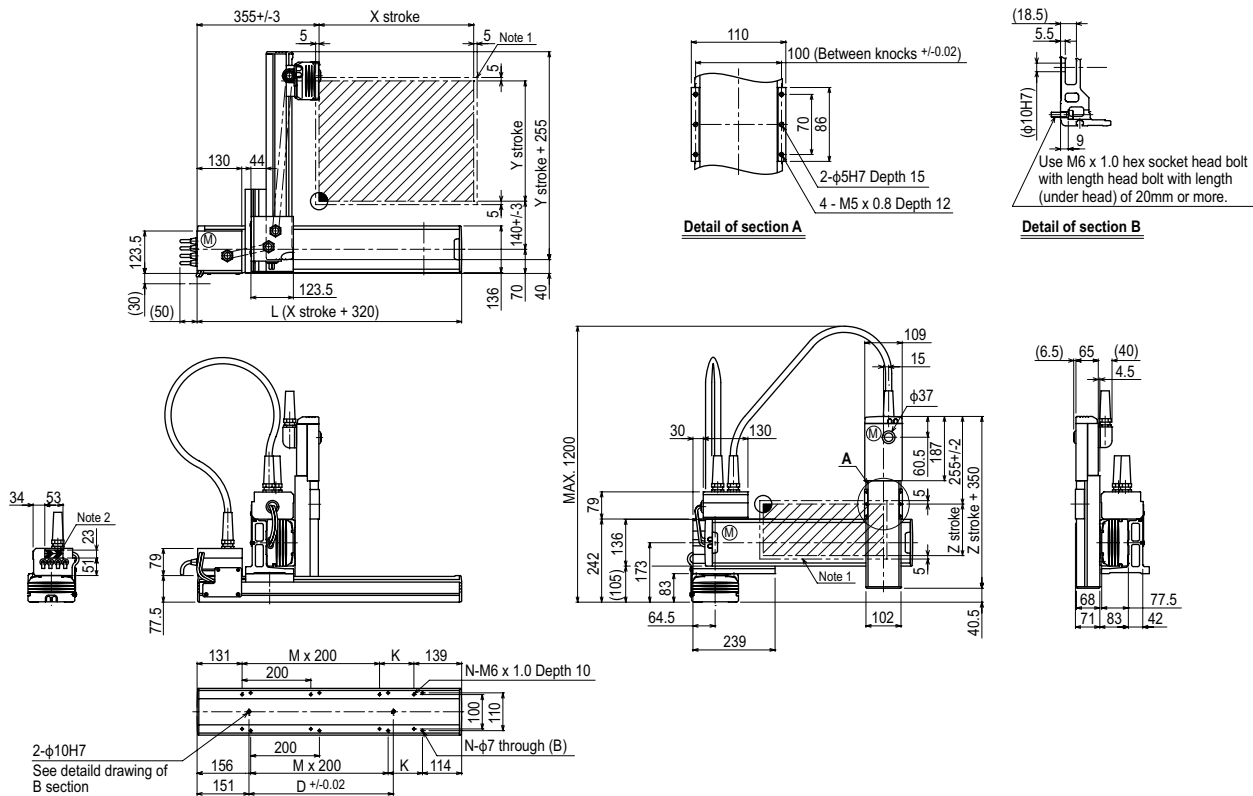

X stroke	150	250	350	450	550	650	750	850	
	L	470	570	670	770	870	970	1070	1170
K	200	100	200	100	200	100	200	100	
D	240	240	420	420	600	600	780	960	
M	0	1	1	2	2	3	3	4	
N	4	6	6	8	8	10	10	12	
Y stroke	150	250	350	450	550	650			
Z stroke	150	250	350						
Maximum speed for each stroke (mm/sec) ^{Note 3}	X-axis	1200					960	780	
	Speed setting	-					80%	65%	

- Note 1. The moving range when returning to origin and the stop position when stopping by the mechanical stopper.
 Note 2. The shaded position indicates an user cable extraction port.

- Note 3. When the X-axis stroke is longer than 750mm, resonance of the ball screw may occur depending on the operation conditions (critical speed). In this case, reduce the speed setting on the program by referring to the maximum speeds shown in the table at the left.

Articulated robots
YA
Linear conveyor modules
LCM100
Motor-less single axis actuator
Robonity
Compact single-axis robots
TRANSEVO
Single-axis robots
FLIP-X
Linear motor single-axis robots
PHASER
Cartesian robots
XY-X
SCARA robots
YK-X
Pick & place robots
YP-X
CLEAN
CONTROLLER INFORMATION
Arm type
Gantry type
Moving arm type
Pole type
XZ type

SXYx 3 axes / ZFL20

- Arm type
- Cable carrier
- Z-axis: clamped base / moving table type (200W)



Ordering method

SXYx - C - **ZFL20** - **RCX340-3**

Model	Cable	Combination	X-axis stroke	Y-axis stroke	ZR-axis	Z-axis stroke	Cable	Controller / Number of controllable axes	Safety standard	Option A (OP.A)	Option B (OP.B)	Option C (OP.C)	Option D (OP.D)	Option E (OP.E)	Absolute battery
		A1 A2 A3 A4	15 to 105cm	15 to 65cm		15 to 35cm	3L: 3.5m 5L: 5m 10L: 10m								

Specify various controller setting items. RCX340 ▶ **P.566**

Specification

	X-axis	Y-axis	Z-axis
Axis construction ^{Note 1}	F14H	F14	F10H-BK
AC servo motor output (W)	200	100	200
Repeatability ^{Note 2} (mm)	+/-0.01	+/-0.01	+/-0.01
Drive system	Ball screw φ15	Ball screw φ15	Ball screw φ15
Ball screw lead ^{Note 3} (Deceleration ratio) (mm)	20	20	20
Maximum speed ^{Note 4} (mm/sec)	1200	1200	1200
Moving range (mm)	150 to 1050	150 to 650	150 to 350
Robot cable length (m)	Standard: 3.5 Option: 5,10		

- Note 1. Use caution that the flange machining (installation holes, tap holes) differs from single-axis robots.
 Note 2. Positioning repeatability in one direction.
 Note 3. Leads not listed in the catalog are also available. Contact us for details.
 Note 4. When the X-axis stroke is longer than 750mm, resonance of the ball screw may occur depending on the operation conditions (critical speed). In this case, reduce the speed setting on the program by referring to the maximum speeds shown in the table below.

Maximum payload (kg)

Y stroke (mm)	Z stroke (mm)		
	150	250	350
150	8	8	8
250	8	8	8
350	8	7	6
450	6	5	4
550	4	3	2
650	2	1	1

Controller

Controller	Operation method
RCX340	Programming / I/O point trace / Remote command / Operation using RS-232C communication

SXYx 3 axes / ZFL20 A1

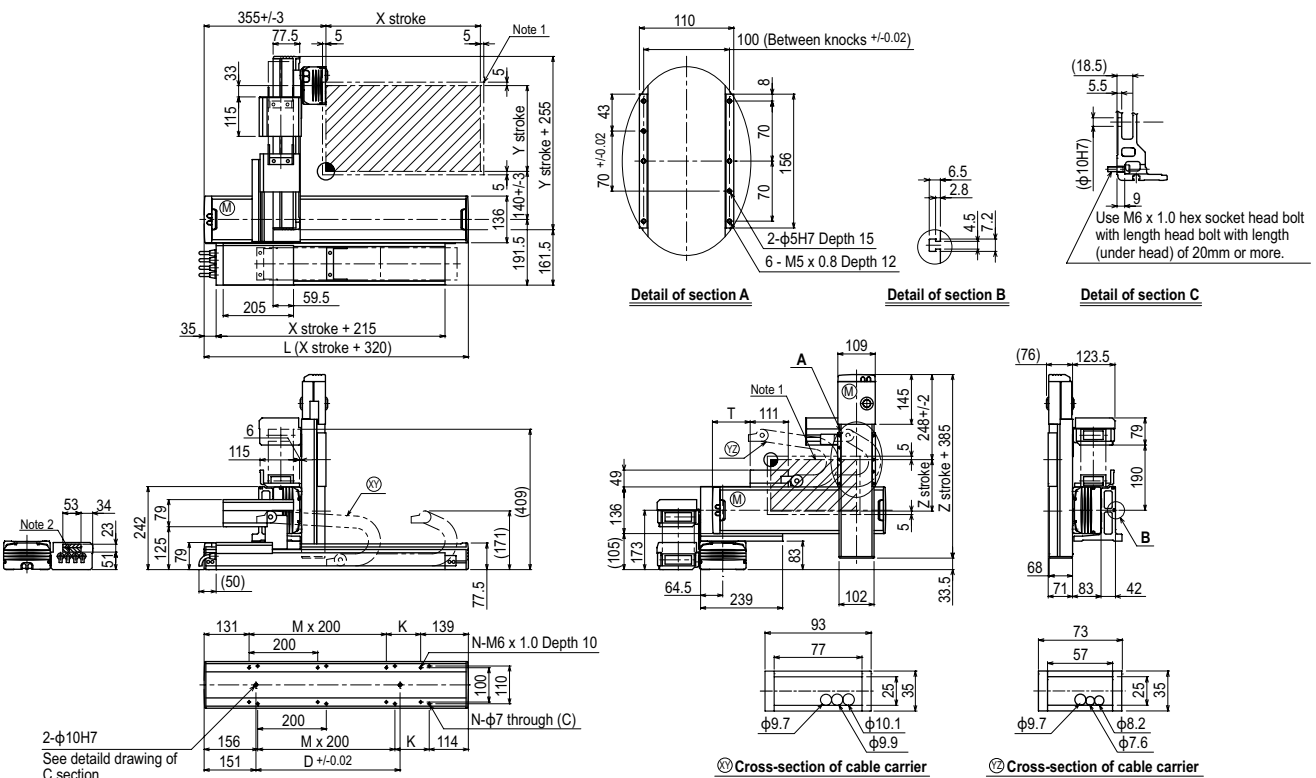

X stroke	150	250	350	450	550	650	750	850	950	1050		
L	470	570	670	770	870	970	1070	1170	1270	1370		
K	200	100	200	100	200	100	200	100	200	100		
D	240	240	420	420	600	600	780	960	960	1140		
M	0	1	1	2	2	3	3	4	4	5		
N	4	6	6	8	8	10	10	12	12	14		
Y stroke	150	250	350	450	550	650						
T	55	110	165	220	275	330						
Z stroke	150	250	350									
Maximum speed for each stroke (mm/sec)	X-axis		1200		960		780		600		540	
Speed setting			-		80%		65%		50%		45%	

- Note 1. The moving range when returning to origin and the stop position when stopping by the mechanical stopper.
 Note 2. The shaded position indicates a user cable extraction port.

- Note 3. When the X-axis stroke is longer than 750mm, resonance of the ball screw may occur depending on the operation conditions (critical speed). In this case, reduce the speed setting on the program by referring to the maximum speeds shown in the table at the left.

SXYx 3 axes / ZFH

● Arm type ● Cable carrier ● Z-axis: clamped table / moving base type (200W)

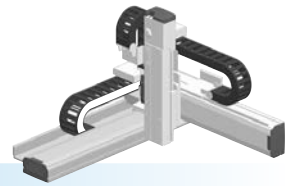

Ordering method

SXYx - C [] [] [] **ZFH** [] [] **RCX340-3** [] [] [] [] [] [] [] [] [] [] []

Model	Cable	Combination	X-axis stroke	Y-axis stroke	ZR-axis	Z-axis stroke	Cable	Controller / Number of controllable axes	Safety standard	Option A (OP.A)	Option B (OP.B)	Option C (OP.C)	Option D (OP.D)	Option E (OP.E)	Absolute battery
A1			15 to 105cm	15 to 65cm		15 to 35cm	3L: 3.5m 5L: 5m 10L: 10m								

Specify various controller setting items. RCX340 ▶ **P.566**

Specification

	X-axis	Y-axis	Z-axis
Axis construction ^{Note 1}	F14H	F14	F10H-BK
AC servo motor output (W)	200	100	200
Repeatability ^{Note 2} (mm)	+/-0.01	+/-0.01	+/-0.01
Drive system	Ball screw φ15	Ball screw φ15	Ball screw φ15
Ball screw lead ^{Note 3} (Deceleration ratio) (mm)	20	20	10
Maximum speed ^{Note 4} (mm/sec)	1200	1200	600
Moving range (mm)	150 to 1050	150 to 650	150 to 350
Robot cable length (m)	Standard: 3.5 Option: 5,10		

Note 1. Use caution that the flange machining (installation holes, tap holes) differs from single-axis robots.
 Note 2. Positioning repeatability in one direction.
 Note 3. Leads not listed in the catalog are also available. Contact us for details.
 Note 4. When the X-axis stroke is longer than 750mm, resonance of the ball screw may occur depending on the operation conditions (critical speed). In this case, reduce the speed setting on the program by referring to the maximum speeds shown in the table below.

Maximum payload (kg)

Y stroke (mm)	Z stroke (mm)		
	150	250	350
150	13	12	11
250	10	9	8
350	8	7	6
450	6	5	4
550	4	3	2
650	2	1	1

Controller

Controller	Operation method
RCX340	Programming / I/O point trace / Remote command / Operation using RS-232C communication

SXYx 3 axes / ZFH A1

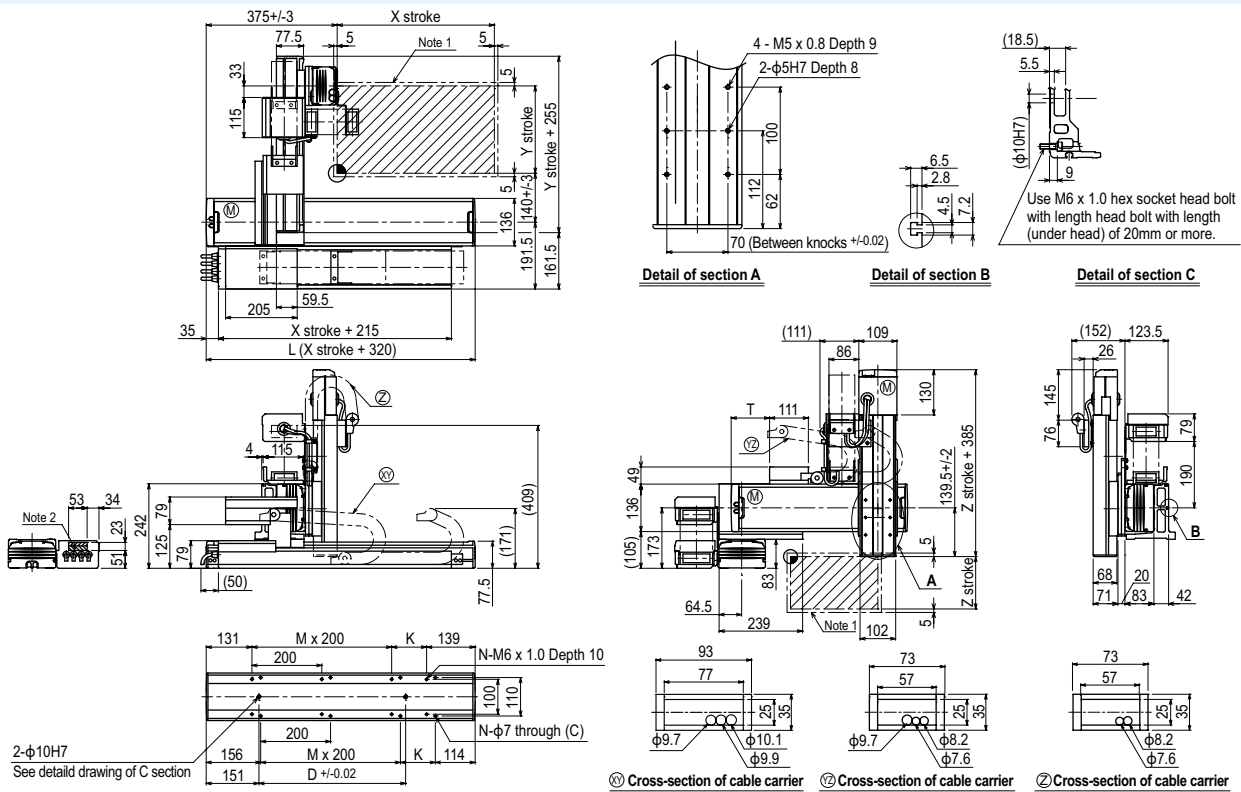

X stroke	150	250	350	450	550	650	750	850	950	1050	
	L	470	570	670	770	870	970	1070	1170	1270	1370
K	200	100	200	100	200	100	200	100	200	100	
D	240	240	420	420	600	600	780	960	960	1140	
M	0	1	1	2	2	3	3	4	4	5	
N	4	6	6	8	8	10	10	12	12	14	
Y stroke	150	250	350	450	550	650					
T	55	110	165	220	275	330					
Z stroke	150	250	350								
Maximum speed for each stroke (mm/sec) ^{Note 3}	X-axis	1200					960	780	600	540	
Speed setting		-					80%	65%	50%	45%	

Note 1. The moving range when returning to origin and the stop position when stopping by the mechanical stopper.
 Note 2. The shaded position indicates an user cable extraction port.

Note 3. When the X-axis stroke is longer than 750mm, resonance of the ball screw may occur depending on the operation conditions (critical speed). In this case, reduce the speed setting on the program by referring to the maximum speeds shown in the table at the left.

Articulated robots
YA
Linear conveyor modules
LCM100
Motor-less single axis actuator
Robonity
Compact single-axis robots
TRANSEVO
Single-axis robots
FLIP-X
Linear motor single-axis robots
PHASER
Cartesian robots
XY-X
SCARA robots
YK-X
Pick & place robots
YP-X
CLEAN
CONTROLLER INFORMATION
Arm type
Gantry type
Moving arm type
Pole type
XZ type

SXYx 3 axes / ZS



- Arm type
- Cable carrier
- Z-axis shaft vertical type

Ordering method

SXYx - C [] [] [] [] **15** [] **RCX340-3** [] [] [] [] [] [] [] [] [] [] []

Model	Cable	Combination	X-axis stroke	Y-axis stroke	ZR-axis	Z-axis stroke	Cable	Controller / Number of controllable axes	Safety standard	Option A (OP.A)	Option B (OP.B)	Option C (OP.C)	Option D (OP.D)	Option E (OP.E)	Absolute battery
		A1	15 to 105cm	15 to 65cm	ZS12		3L: 3.5m 5L: 5m 10L: 10m								
		A2			ZS6										
		A3													
		A4													

Specify various controller setting items. RCX340 ▶ **P.566**

Specification

	X-axis	Y-axis	Z-axis ZS12	Z-axis ZS6
Axis construction <small>Note 1</small>	F14H	F14	-	
AC servo motor output (W)	200	100	60	
Repeatability <small>Note 2</small> (mm)	+/-0.01	+/-0.01	+/-0.02	
Drive system	Ball screw φ15	Ball screw φ15	Ball screw φ12	
Ball screw lead <small>Note 3</small> (Deceleration ratio) (mm)	20	20	12	6
Maximum speed <small>Note 4</small> (mm/sec)	1200	1200	1000	500
Moving range (mm)	150 to 1050	150 to 650	150	
Robot cable length (m)	Standard: 3.5 Option: 5, 10			

Note 1. Use caution that the flame machining (installation holes, tap holes) differs from single-axis robots.
 Note 2. Positioning repeatability in one direction.
 Note 3. Leads not listed in the catalog are also available. Contact us for details.
 Note 4. When the X-axis stroke is longer than 750mm, resonance of the ball screw may occur depending on the operation conditions (critical speed). In this case, reduce the speed setting on the program by referring to the maximum speeds shown in the table below.

Maximum payload (kg)

Y stroke (mm)	ZS12	ZS6
150 to 650	3	5

Controller

Controller	Operation method
RCX340	Programming / I/O point trace / Remote command / Operation using RS-232C communication

SXYx 3 axes / ZS (A1)

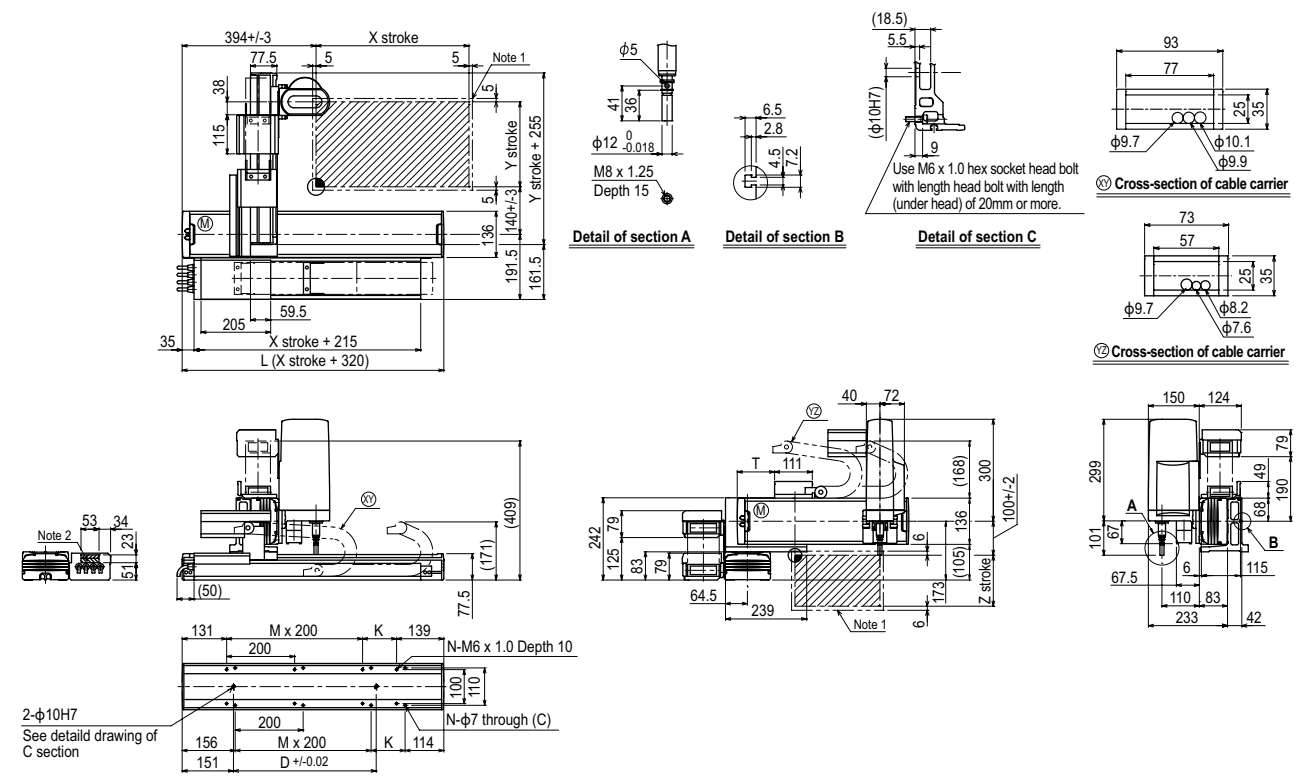

X stroke	150	250	350	450	550	650	750	850	950	1050
L	470	570	670	770	870	970	1070	1170	1270	1370
K	200	100	200	100	200	100	200	100	200	100
D	240	240	420	420	600	600	780	960	960	1140
M	0	1	1	2	2	3	3	4	4	5
N	4	6	6	8	8	10	10	12	12	14
Y stroke	150	250	350	450	550	650				
T	55	110	165	215	270	325				
Z stroke	150									
Maximum speed for each stroke (mm/sec) <small>Note 3</small>	X-axis		1200			960	780	600	540	
Speed setting			-			80%	65%	50%	45%	

Note 1. The moving range when returning to origin and the stop position when stopping by the mechanical stopper.
 Note 2. The shaded position indicates a user cable extraction port.

Note 3. When the X-axis stroke is longer than 750mm, resonance of the ball screw may occur depending on the operation conditions (critical speed). In this case, reduce the speed setting on the program by referring to the maximum speeds shown in the table at the left.

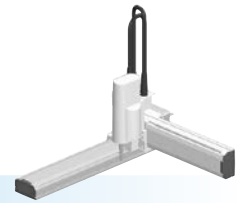

Ordering method

SXYx - S [] [] [] [] **15** [] **RCX340-3** [] [] [] [] [] [] [] [] [] [] [] []

Model	Cable	Combination	X-axis stroke	Y-axis stroke	ZR-axis	Z-axis stroke	Cable	Controller / Number of controllable axes	Safety standard	Option A (OP.A)	Option B (OP.B)	Option C (OP.C)	Option D (OP.D)	Option E (OP.E)	Absolute battery	
A1			15 to 85cm	15 to 65cm	ZS12		3L: 3.5m	Specify various controller setting items. RCX340 ▶ P.566								
A2					ZS6		5L: 5m									
A3							10L: 10m									
A4																

Specification

	X-axis	Y-axis	Z-axis: ZS12	Z-axis: ZS6
Axis construction ^{Note 1}	F14H	F14	-	
AC servo motor output (W)	200	100	60	
Repeatability ^{Note 2} (mm)	+/-0.01	+/-0.01	+/-0.02	
Drive system	Ball screw φ15	Ball screw φ15	Ball screw φ12	
Ball screw lead ^{Note 3} (Deceleration ratio) (mm)	20	20	12	6
Maximum speed ^{Note 4} (mm/sec)	1200	1200	1000	500
Moving range (mm)	150 to 850	150 to 650	150	
Robot cable length (m)	Standard: 3.5 Option: 5,10			

Note 1. Use caution that the flame machining (installation holes, tap holes) differs from single-axis robots.
 Note 2. Positioning repeatability in one direction.
 Note 3. Leads not listed in the catalog are also available. Contact us for details.
 Note 4. When the X-axis stroke is longer than 750mm, resonance of the ball screw may occur depending on the operation conditions (critical speed). In this case, reduce the speed setting on the program by referring to the maximum speeds shown in the table below.

Maximum payload (kg)

Y stroke (mm)	ZS12	ZS6
150 to 650	3	5

Controller

Controller	Operation method
RCX340	Programming / I/O point trace / Remote command / Operation using RS-232C communication

SXYx 3 axes / ZS (A1)

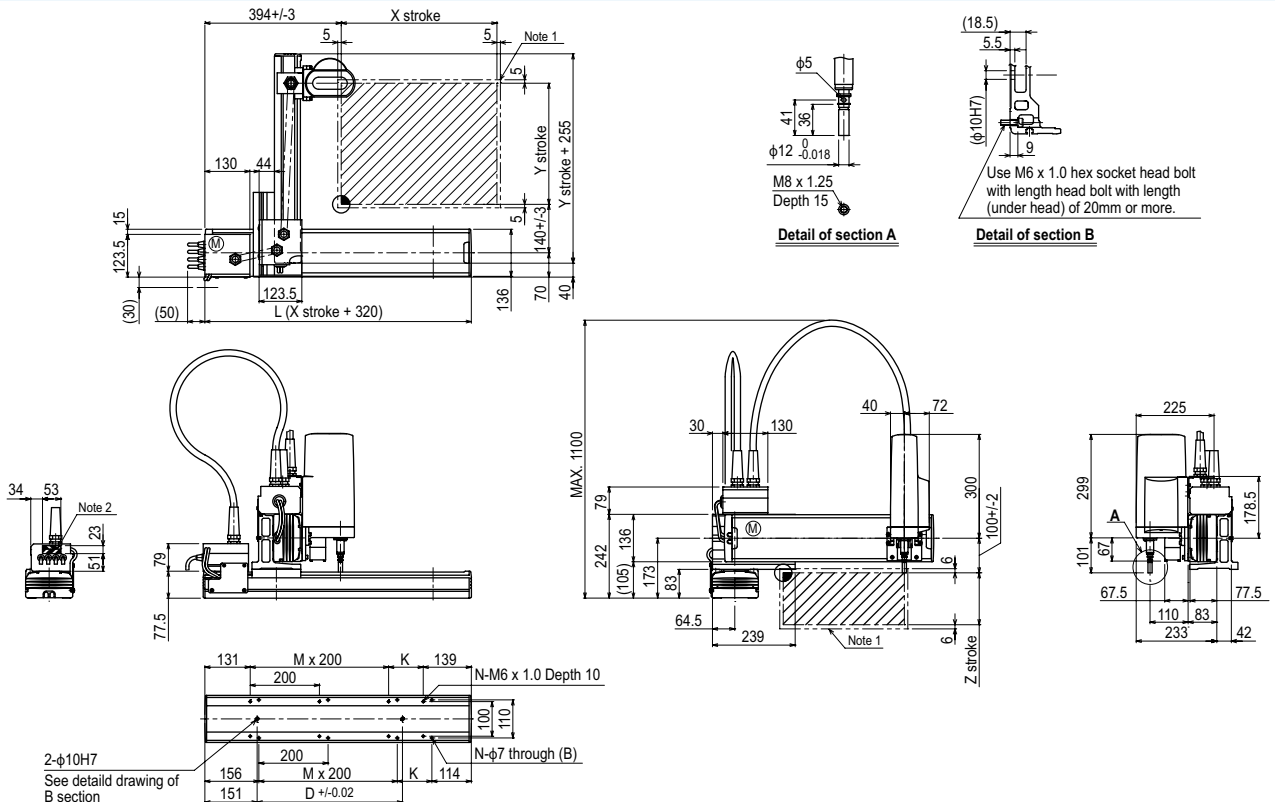

X stroke	150	250	350	450	550	650	750	850
L	470	570	670	770	870	970	1070	1170
K	200	100	200	100	200	100	200	100
D	240	240	420	420	600	600	780	960
M	0	1	1	2	2	3	3	4
N	4	6	6	8	8	10	10	12
Y stroke	150	250	350	450	550	650		
Z stroke	150							
Maximum speed for each stroke (mm/sec) ^{Note 3}	X-axis		1200			960		780
Speed setting			-			80%		65%

Note 1. The moving range when returning to origin and the stop position when stopping by the mechanical stopper.
 Note 2. The shaded position indicates a user cable extraction port.

Note 3. When the X-axis stroke is longer than 750mm, resonance of the ball screw may occur depending on the operation conditions (critical speed). In this case, reduce the speed setting on the program by referring to the maximum speeds shown in the table at the left.

Articulated robots
YA
Linear conveyor modules
LCM100
Motor-less single axis actuator
Robonity
Compact single-axis robots
TRANSEVO
Single-axis robots
FLIP-X
Linear motor single-axis robots
PHASER
Cartesian robots
XX-X
SCARA robots
YK-X
Pick & place robots
YP-X
CLEAN
CONTROLLER INFORMATION
Arm type
Gantry type
Moving arm type
Pole type
XZ type

SXYx 4 axes / ZRF

● Arm type ● Cable carrier ● Z-axis: clamped base / moving table type (100W)+R-axis

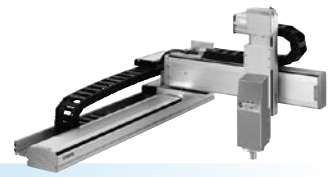

Ordering method

SXYx - C [] [] [] **ZRF** [] [] **RCX340-4** [] [] [] [] [] [] []

Model	Cable	Combination	X-axis stroke	Y-axis stroke	ZR-axis	Z-axis stroke	Cable	Controller / Number of controllable axes	Safety standard	Option A (OP.A)	Option B (OP.B)	Option C (OP.C)	Option D (OP.D)	Option E (OP.E)	Absolute battery
A1		A1	15 to 105cm	15 to 65cm		15 to 35cm	3L: 3.5m 5L: 5m 10L: 10m								

Specify various controller setting items. RCX340 ▶ **P.566**

Specification

	X-axis	Y-axis	Z-axis	R-axis
Axis construction <small>Note 1</small>	F14H	F14	F10-BK	R5
AC servo motor output (W)	200	100	100	50
Repeatability <small>Note 2</small> (XYZ: mm) (R: °)	+/-0.01	+/-0.01	+/-0.01	+/-0.0083
Drive system	Ball screw φ15	Ball screw φ15	Ball screw φ15	Harmonic gear
Ball screw lead <small>Note 3</small> (Deceleration ratio) (mm)	20	20	10	(1/50)
Maximum speed <small>Note 4</small> (XYZ: mm/sec) (R: °/sec)	1200	1200	600	360
Moving range (XYZ: mm) (R: °)	150 to 1050	150 to 650	150 to 350	360
Robot cable length (m)	Standard: 3.5 Option: 5, 10			

Note 1. Use caution that the flame machining (installation holes, tap holes) differs from single-axis robots.
 Note 2. Positioning repeatability in one direction.
 Note 3. Leads not listed in the catalog are also available. Contact us for details.
 Note 4. When the X-axis stroke is longer than 750mm, resonance of the ball screw may occur depending on the operation conditions (critical speed). In this case, reduce the speed setting on the program by referring to the maximum speeds shown in the table below.

Maximum payload (kg)

Y stroke (mm)	Z stroke (mm)		
	150	250	350
150	6	6	6
250	6	5	4
350	4	3	2
450	3	2	1
550	2	1	-
650	1	-	-

Controller

Controller	Operation method
RCX340	Programming / I/O point trace / Remote command / Operation using RS-232C communication

SXYx 4 axes / ZRF (A1)

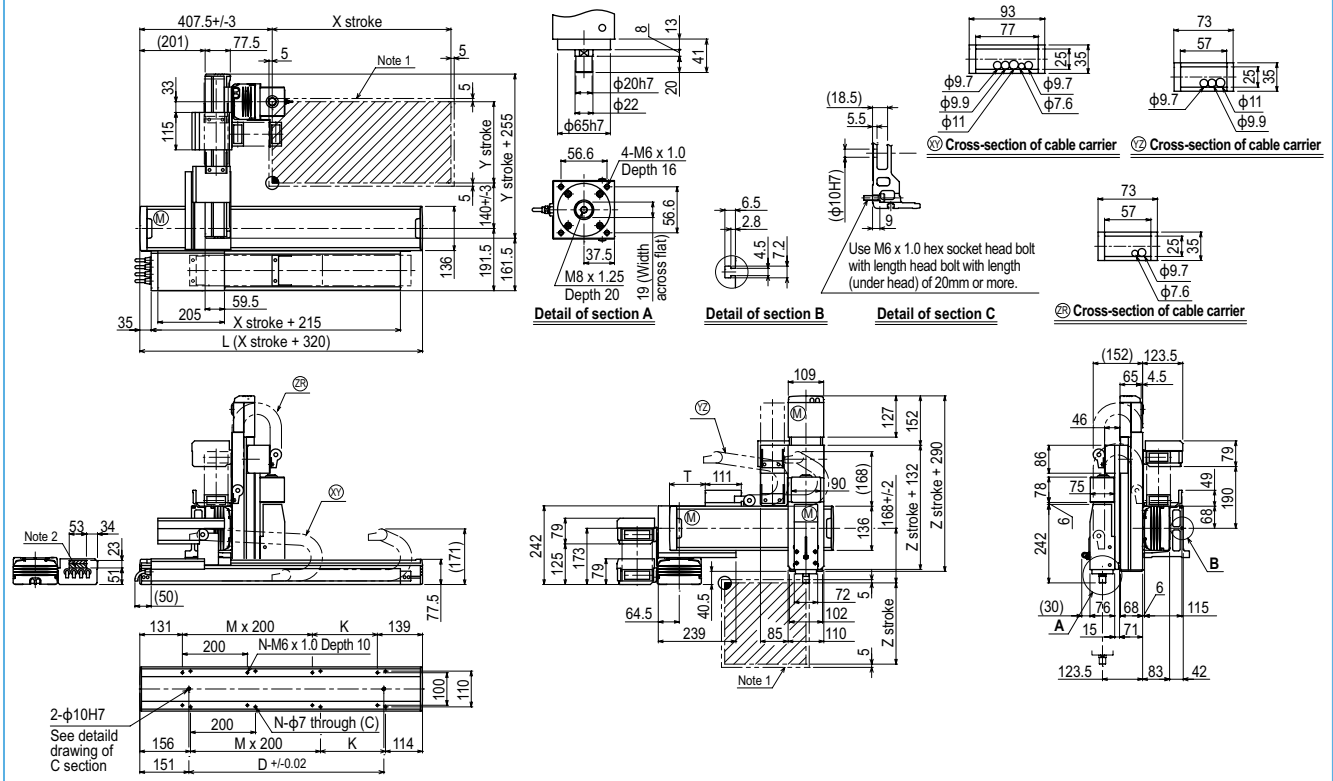

X stroke	L (X stroke + 320)									
	150	250	350	450	550	650	750	850	950	1050
L	470	570	670	770	870	970	1070	1170	1270	1370
K	200	100	200	100	200	100	200	100	200	100
D	240	240	420	420	600	600	780	960	960	1140
M	0	1	1	2	2	3	3	4	4	5
N	4	6	6	8	8	10	10	12	12	14
Y stroke	Z stroke									
	150	250	350	450	550	650				
T	55	110	165	220	275	330				
Maximum speed for each stroke (mm/sec)	X-axis	1200								
	Speed setting	-								
Maximum speed for each stroke (mm/sec)	X-axis	960								
	Speed setting	80%								
Maximum speed for each stroke (mm/sec)	X-axis	780								
	Speed setting	65%								
Maximum speed for each stroke (mm/sec)	X-axis	600								
	Speed setting	50%								
Maximum speed for each stroke (mm/sec)	X-axis	540								
	Speed setting	45%								

Note 1. The moving range when returning to origin and the stop position when stopping by the mechanical stopper.
 Note 2. The shaded position indicates a user cable extraction port.

Note 3. When the X-axis stroke is longer than 750mm, resonance of the ball screw may occur depending on the operation conditions (critical speed). In this case, reduce the speed setting on the program by referring to the maximum speeds shown in the table at the left.

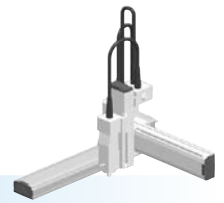

Ordering method

SXYx - S [] [] [] - **ZRF** [] [] [] - **RCX340-4** [] [] [] [] [] [] [] [] [] [] [] [] [] [] []

Model	Cable	Combination	X-axis stroke	Y-axis stroke	ZR-axis	Z-axis stroke	Cable	Controller / Number of controllable axes	Safety standard	Option A (OP.A)	Option B (OP.B)	Option C (OP.C)	Option D (OP.D)	Option E (OP.E)	Absolute battery
		A1	15 to 85cm	15 to 65cm		15 to 35cm	3L: 3.5m 5L: 5m 10L: 10m								

Specify various controller setting items. RCX340 ▶ P.566

Specification

	X-axis	Y-axis	Z-axis	R-axis
Axis construction ^{Note 1}	F14H	F14	F10-BK	R5
AC servo motor output (W)	200	100	100	50
Repeatability ^{Note 2} (XYZ: mm) (R: °)	+/-0.01	+/-0.01	+/-0.01	+/-0.0083
Drive system	Ball screw φ15	Ball screw φ15	Ball screw φ15	Harmonic gear
Ball screw lead ^{Note 3} (Deceleration ratio) (mm)	20	20	10	(1/50)
Maximum speed ^{Note 4} (XYZ: mm/sec) (R: °/sec)	1200	1200	600	360
Moving range (XYZ: mm) (R: °)	150 to 850	150 to 650	150 to 350	360
Robot cable length (m)	Standard: 3.5 Option: 5, 10			

Note 1. Use caution that the flame machining (installation holes, tap holes) differs from single-axis robots.
 Note 2. Positioning repeatability in one direction.
 Note 3. Leads not listed in the catalog are also available. Contact us for details.
 Note 4. When the X-axis stroke is longer than 750mm, resonance of the ball screw may occur depending on the operation conditions (critical speed). In this case, reduce the speed setting on the program by referring to the maximum speeds shown in the table below.

Maximum payload (kg)

Y stroke (mm)	Z stroke (mm)		
	150	250	350
150	6	6	6
250	6	5	4
350	4	3	2
450	3	2	1
550	2	1	-
650	1	-	-

Controller

Controller	Operation method
RCX340	Programming / I/O point trace / Remote command / Operation using RS-232C communication

SXYx 4 axes / ZRF (A1)

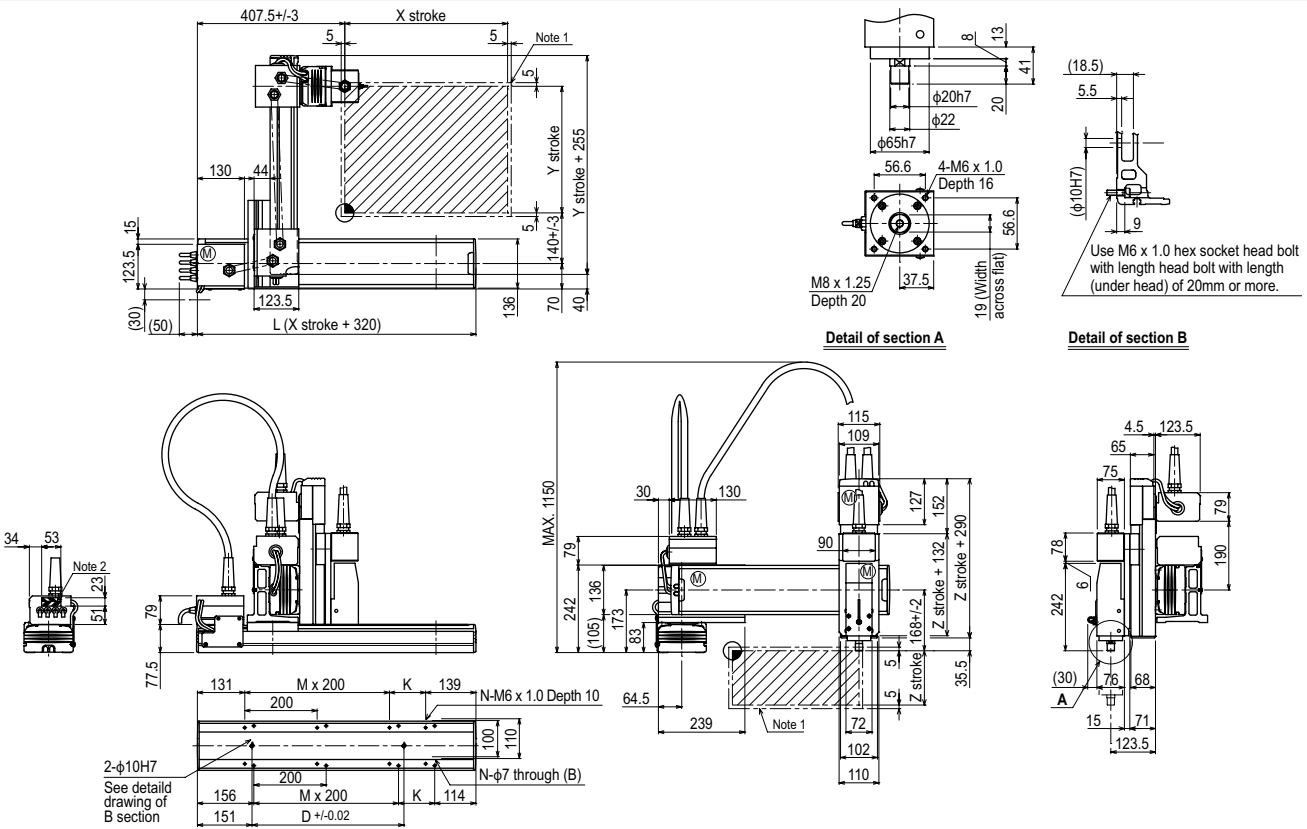

X stroke	150	250	350	450	550	650	750	850
	L	470	570	670	770	870	970	1070
K	200	100	200	100	200	100	200	100
D	240	240	420	420	600	600	780	960
M	0	1	1	2	2	3	3	4
N	4	6	6	8	8	10	10	12

Y stroke	150	250	350	450	550	650
	Z stroke	150	250	350		

Maximum speed for each stroke (mm/sec)	X-axis	1200	960	780
	Speed setting		-	80%

Note 1. The moving range when returning to origin and the stop position when stopping by the mechanical stopper.
 Note 2. The shaded position indicates a user cable extraction port.
 Note 3. When the X-axis stroke is longer than 750mm, resonance of the ball screw may occur depending on the operation conditions (critical speed). In this case, reduce the speed setting on the program by referring to the maximum speeds shown in the table at the left.

SXYx 4 axes / ZRFL20

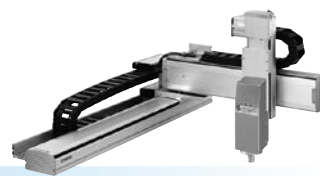

● Arm type ● Cable carrier ● Z-axis: clamped base / moving table type (200W)+R-axis

Ordering method

SXYx-C [] [] [] - **ZRFL20** [] [] [] - **RCX340-4** [] [] [] [] [] [] [] [] []

Model	Cable	Combination	X-axis stroke	Y-axis stroke	ZR-axis	Z-axis stroke	Cable	Controller / Number of controllable axes	Safety standard	Option A (OP.A)	Option B (OP.B)	Option C (OP.C)	Option D (OP.D)	Option E (OP.E)	Absolute battery
		A1	15 to 105mm	15 to 55mm		15 to 35mm	3L: 3.5m 5L: 5m 10L: 10m								

Specify various controller setting items. RCX340 ▶ P.566

Specification

	X-axis	Y-axis	Z-axis	R-axis
Axis construction ^{Note 1}	F14H	F14	F10H-BK	R5
AC servo motor output (W)	200	100	200	50
Repeatability ^{Note 2} (XYZ: mm) (R: °)	+/-0.01	+/-0.01	+/-0.01	+/-0.0083
Drive system	Ball screw φ15	Ball screw φ15	Ball screw φ15	Harmonic gear
Ball screw lead ^{Note 3} (Deceleration ratio) (mm)	20	20	20	(1/50)
Maximum speed ^{Note 4} (XYZ: mm/sec) (R: °/sec)	1200	1200	1200	360
Moving range (XYZ: mm) (R: °)	150 to 1050	150 to 550	150 to 350	360
Robot cable length (m)	Standard: 3.5 Option: 5, 10			

Note 1. Use caution that the flame machining (installation holes, tap holes) differs from single-axis robots.
 Note 2. Positioning repeatability in one direction.
 Note 3. Leads not listed in the catalog are also available. Contact us for details.
 Note 4. When the X-axis stroke is longer than 750mm, resonance of the ball screw may occur depending on the operation conditions (critical speed). In this case, reduce the speed setting on the program by referring to the maximum speeds shown in the table below.

Maximum payload (kg)

Y stroke (mm)	Z stroke (mm)		
	150	250	350
150	4	4	4
250	4	4	3
350	4	3	1
450	2	1	-
550	1	-	-

Controller

Controller	Operation method
RCX340	Programming / I/O point trace / Remote command / Operation using RS-232C communication

SXYx 4 axes / ZRFL20 A1

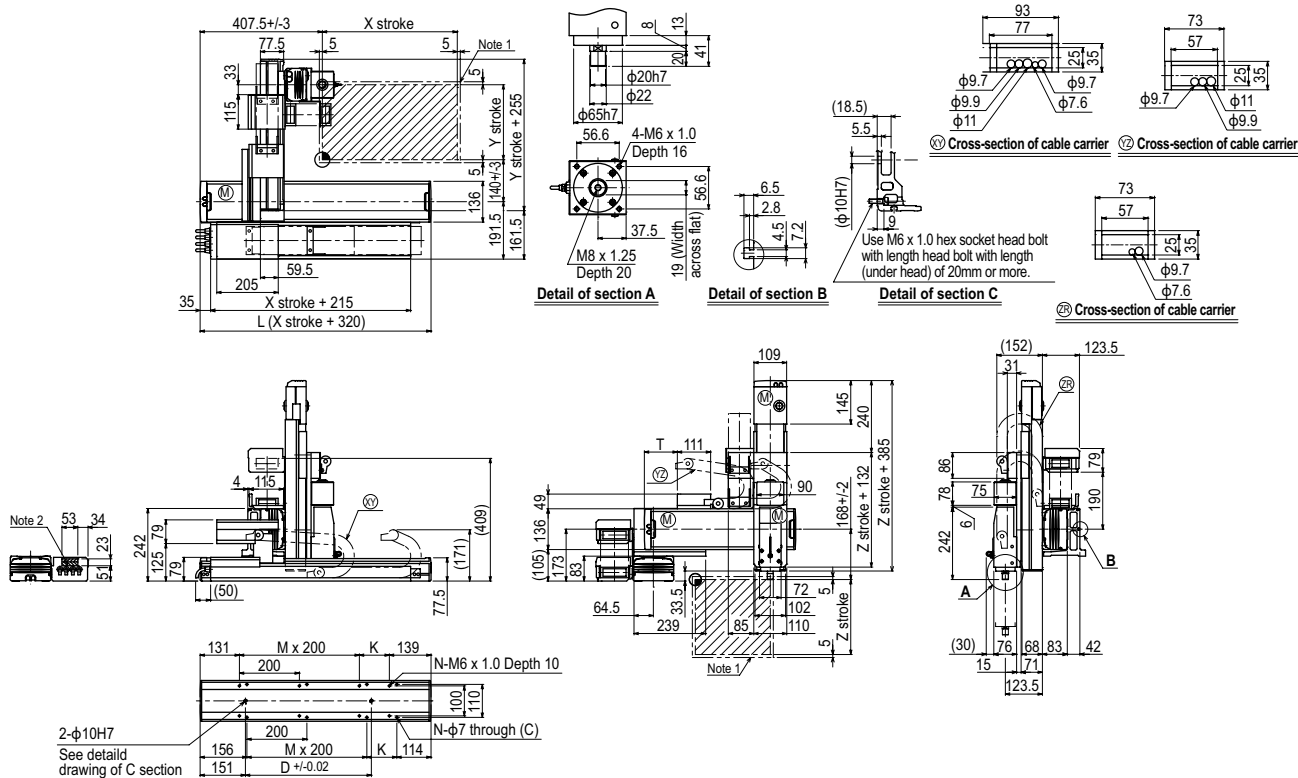

X stroke	150	250	350	450	550	650	750	850	950	1050
	L	470	570	670	770	870	970	1070	1170	1270
K	200	100	200	100	200	100	200	100	200	100
D	240	240	420	420	600	600	780	960	960	1140
M	0	1	1	2	2	3	3	4	4	5
N	4	6	6	8	8	10	10	12	12	14

Y stroke	150	250	350	450	550
	T	55	110	165	220

Z stroke	150	250	350			
	Maximum speed for each stroke (mm/sec) ^{Note 3}	X-axis	1200	960	780	600
Speed setting		-	80%	65%	50%	45%

Note 1. The moving range when returning to origin and the stop position when stopping by the mechanical stopper.
 Note 2. The shaded position indicates a user cable extraction port.

Note 3. When the X-axis stroke is longer than 750mm, resonance of the ball screw may occur depending on the operation conditions (critical speed). In this case, reduce the speed setting on the program by referring to the maximum speeds shown in the table at the left.

● Arm type

● Cable carrier

● Z-axis: clamped table / moving base type (200W)+R-axis

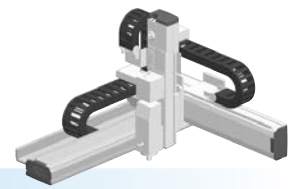

Ordering method

SXYx - C - **ZRFH** - - - - - - **RCX340-4** - - - - - - - - -

Model	Cable	Combination	X-axis stroke	Y-axis stroke	ZR-axis	Z-axis stroke	Cable	Controller / Number of controllable axes	Safety standard	Option A (OP.A)	Option B (OP.B)	Option C (OP.C)	Option D (OP.D)	Option E (OP.E)	Absolute battery
A1	15 to 105cm	15 to 55cm	15 to 105cm	15 to 55cm	15 to 35cm	3L: 3.5m 5L: 5m 10L: 10m	3: 3.5m 5: 5m 10: 10m	Specify various controller setting items. RCX340 ▶ P.566							

Specification

	X-axis	Y-axis	Z-axis	R-axis
Axis construction <small>Note 1</small>	F14H	F14	F10H-BK	R5
AC servo motor output (W)	200	100	200	50
Repeatability <small>Note 2 (XYZ: mm) (R: °)</small>	+/-0.01	+/-0.01	+/-0.01	+/-0.0083
Drive system	Ball screw φ15	Ball screw φ15	Ball screw φ15	Harmonic gear
Ball screw lead <small>Note 3 (Deceleration ratio) (mm)</small>	20	20	10	(1/50)
Maximum speed <small>Note 4 (XYZ: mm/sec) (R: °/sec)</small>	1200	1200	600	360
Moving range (XYZ: mm)(R: °)	150 to 1050	150 to 550	150 to 350	360
Robot cable length (m)	Standard: 3.5 Option: 5, 10			

Note 1. Use caution that the flame machining (installation holes, tap holes) differs from single-axis robots.
 Note 2. Positioning repeatability in one direction.
 Note 3. Leads not listed in the catalog are also available. Contact us for details.
 Note 4. When the X-axis stroke is longer than 750mm, resonance of the ball screw may occur depending on the operation conditions (critical speed). In this case, reduce the speed setting on the program by referring to the maximum speeds shown in the table below.

Maximum payload (kg)

Y stroke (mm)	Z stroke (mm)		
	150	250	350
150	9	8	7
250	6	5	4
350	4	3	1
450	2	1	-
550	1	-	-

Controller

Controller	Operation method
RCX340	Programming / I/O point trace / Remote command / Operation using RS-232C communication

SXYx 4 axes / ZRFH (A1)

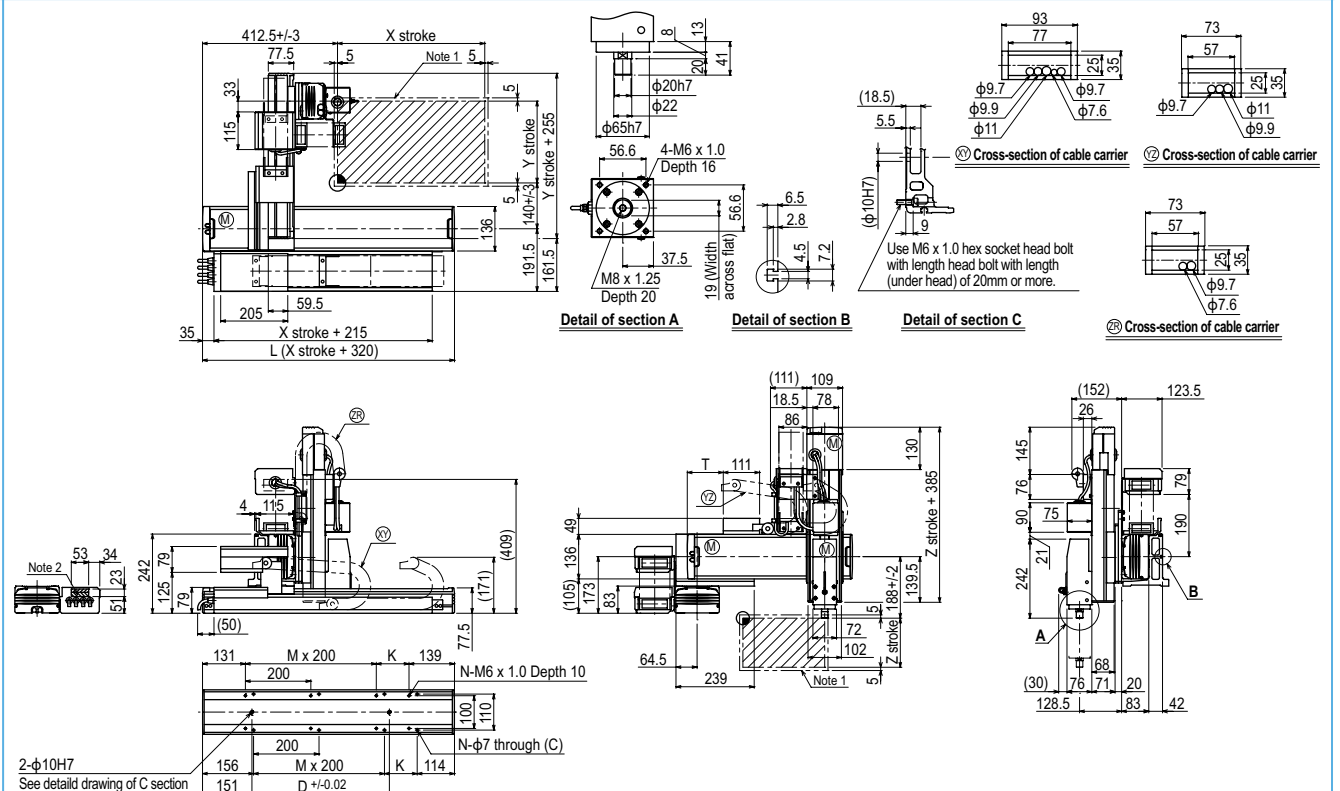

	X stroke											
	150	250	350	450	550	650	750	850	950	1050		
L	470	570	670	770	870	970	1070	1170	1270	1370		
K	200	100	200	100	200	100	200	100	200	100		
D	240	240	420	420	600	600	780	960	960	1140		
M	0	1	1	2	2	3	3	4	4	5		
N	4	6	6	8	8	10	10	12	12	14		
Y stroke												
T	55	110	165	220	275							
Z stroke	150	250	350									
Maximum speed for each stroke (mm/sec) <small>Note 3</small>	X-axis				Z-axis							
Speed setting	-				-				80%	65%	50%	45%

Note 1. The moving range when returning to origin and the stop position when stopping by the mechanical stopper.
 Note 2. The shaded position indicates an user cable extraction port.
 Note 3. When the X-axis stroke is longer than 750mm, resonance of the ball screw may occur depending on the operation conditions (critical speed). In this case, reduce the speed setting on the program by referring to the maximum speeds shown in the table at the left.

Articulated robots
 YA
 Linear conveyor modules
 LCM100
 Motor-less single-axis actuator
 Robonity
 Compact single-axis robots
 TRANSEVO
 Single-axis robots
 FLIP-X
 Linear motor single-axis robots
 PHASER
 Cartesian robots
 XX-X
 SCARA robots
 YK-X
 Pick & place robots
 YP-X
 CLEAN
 CONTROLLER INFORMATION
 Arm type
 Gantry type
 Moving arm type
 Pole type
 XZ type

SXYx

4 axes / ZRS



- Arm type
- Cable carrier
- ZR axis integrated type

Ordering method

SXYx - C					15		RCX340-4								
Model	Cable	Combination	X-axis stroke	Y-axis stroke	ZR-axis	Z-axis stroke	Cable	Controller / Number of controllable axes	Safety standard	Option A (OP.A)	Option B (OP.B)	Option C (OP.C)	Option D (OP.D)	Option E (OP.E)	Absolute battery
		A1 A2 A3 A4	15 to 105cm	15 to 65cm	ZRS12 ZRS6		3L: 3.5m 5L: 5m 10L: 10m								

Specify various controller setting items. RCX340 ▶ **P.566**

Specification

	X-axis	Y-axis	Z-axis: ZRS12	Z-axis: ZRS6	R-axis
Axis construction <small>Note 1</small>	F14H	F14	-		-
AC servo motor output (W)	200	100	60		100
Repeatability <small>Note 2</small> (XYZ: mm) (R: °)	+/-0.01	+/-0.01	+/-0.02		+/-0.005
Drive system	Ball screw φ15	Ball screw φ15	Ball screw φ12		Harmonic gear
Ball screw lead <small>Note 3</small> (Deceleration ratio) (mm)	20	20	12	6	(1/50)
Maximum speed <small>Note 4</small> (XYZ: mm/sec) (R: °/sec)	1200	1200	1000	500	1020
Moving range (XYZ: mm) (R: °)	150 to 1050	150 to 650	150		360
Robot cable length (m)	Standard: 3.5 Option: 5,10				

Note 1. Use caution that the flame machining (installation holes, tap holes) differs from single-axis robots.
 Note 2. Positioning repeatability in one direction.
 Note 3. Leads not listed in the catalog are also available. Contact us for details.
 Note 4. When the X-axis stroke is longer than 750mm, resonance of the ball screw may occur depending on the operation conditions (critical speed). In this case, reduce the speed setting on the program by referring to the maximum speeds shown in the table below.

Maximum payload (kg)

Y stroke (mm)	ZRS12	ZRS6
150	3	5
250	3	5
350	3	5
450	3	5
550	3	5
650	3	4

Controller

Controller	Operation method
RCX340	Programming / I/O point trace / Remote command / Operation using RS-232C communication

SXYx 4 axes / ZRS (A1)

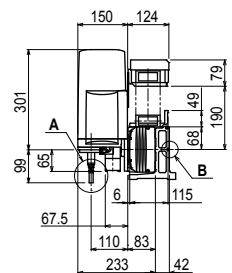
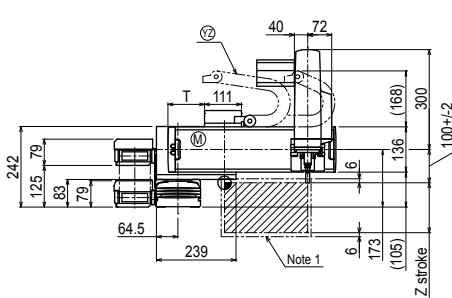
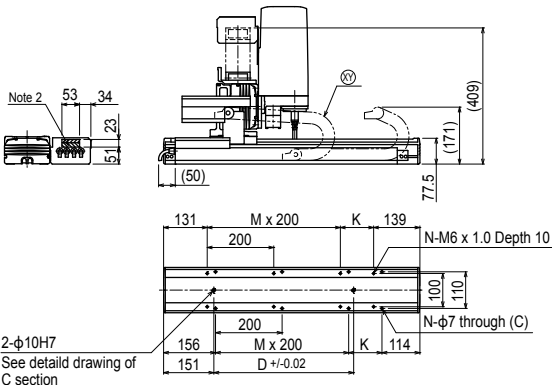
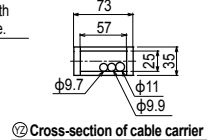
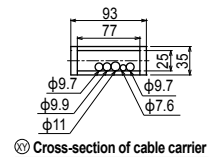
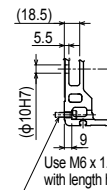
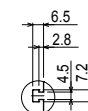
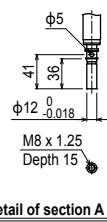
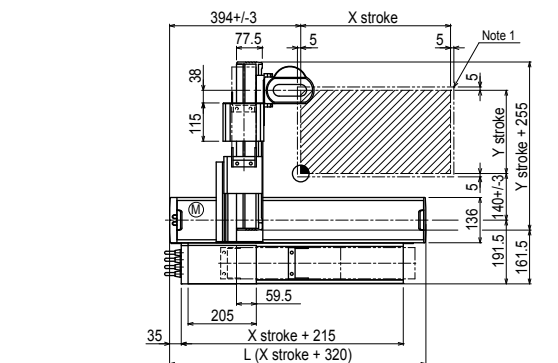

X stroke	150	250	350	450	550	650	750	850	950	1050
L	470	570	670	770	870	970	1070	1170	1270	1370
K	200	100	200	100	200	100	200	100	200	100
D	240	240	420	420	600	600	780	960	960	1140
M	0	1	1	2	2	3	3	4	4	5
N	4	6	6	8	8	10	10	12	12	14
Y stroke	150	250	350	450	550	650				
T	55	110	165	220	275	330				
Z stroke	150									
Maximum speed for each stroke (mm/sec) <small>Note 3</small>			1200			960	780	600	540	
Speed setting			-			80%	65%	50%	45%	

Note 1. The moving range when returning to origin and the stop position when stopping by the mechanical stopper.
 Note 2. The shaded position indicates a user cable extraction port.

Note 3. When the X-axis stroke is longer than 750mm, resonance of the ball screw may occur depending on the operation conditions (critical speed). In this case, reduce the speed setting on the program by referring to the maximum speeds shown in the table at the left.



Ordering method

SXYx - S [] [] [] [] **15** [] **RCX340-4** [] [] [] [] [] [] [] [] [] []

Model	Cable	Combination	X-axis stroke	Y-axis stroke	ZR-axis	Z-axis stroke	Cable	Controller / Number of controllable axes	Safety standard	Option A (OP.A)	Option B (OP.B)	Option C (OP.C)	Option D (OP.D)	Option E (OP.E)	Absolute battery
A1			15 to 85cm	15 to 65cm	ZRS12		3L: 3.5m 5L: 5m 10L: 10m								
A2					ZRS6										
A3															
A4															

Specify various controller setting items. RCX340 ▶ **P.566**

Specification

	X-axis	Y-axis	Z-axis: ZRS12	Z-axis: ZRS6	R-axis
Axis construction ^{Note 1}	F14H	F14	-	-	-
AC servo motor output (W)	200	100	60		100
Repeatability ^{Note 2} (XYZ: mm) (R: °)	+/-0.01	+/-0.01	+/-0.02		+/-0.005
Drive system	Ball screw φ15	Ball screw φ15	Ball screw φ12		Harmonic gear
Ball screw lead ^{Note 3} (Deceleration ratio) (mm)	20	20	12	6	(1/50)
Maximum speed ^{Note 4} (XYZ: mm/sec) (R: °/sec)	1200	1200	1000	500	1020
Moving range (XYZ: mm) (R: °)	150 to 850	150 to 650	150		360
Robot cable length (m)	Standard: 3.5 Option: 5,10				

Note 1. Use caution that the flame machining (installation holes, tap holes) differs from single-axis robots.
 Note 2. Positioning repeatability in one direction.
 Note 3. Leads not listed in the catalog are also available. Contact us for details.
 Note 4. When the X-axis stroke is longer than 750mm, resonance of the ball screw may occur depending on the operation conditions (critical speed). In this case, reduce the speed setting on the program by referring to the maximum speeds shown in the table below.

Maximum payload (kg)

Y stroke (mm)	ZRS12	ZRS6
150	3	5
250	3	5
350	3	5
450	3	5
550	3	5
650	3	4

Controller

Controller	Operation method
RCX340	Programming / I/O point trace / Remote command / Operation using RS-232C communication

SXYx 4 axes / ZRS A1

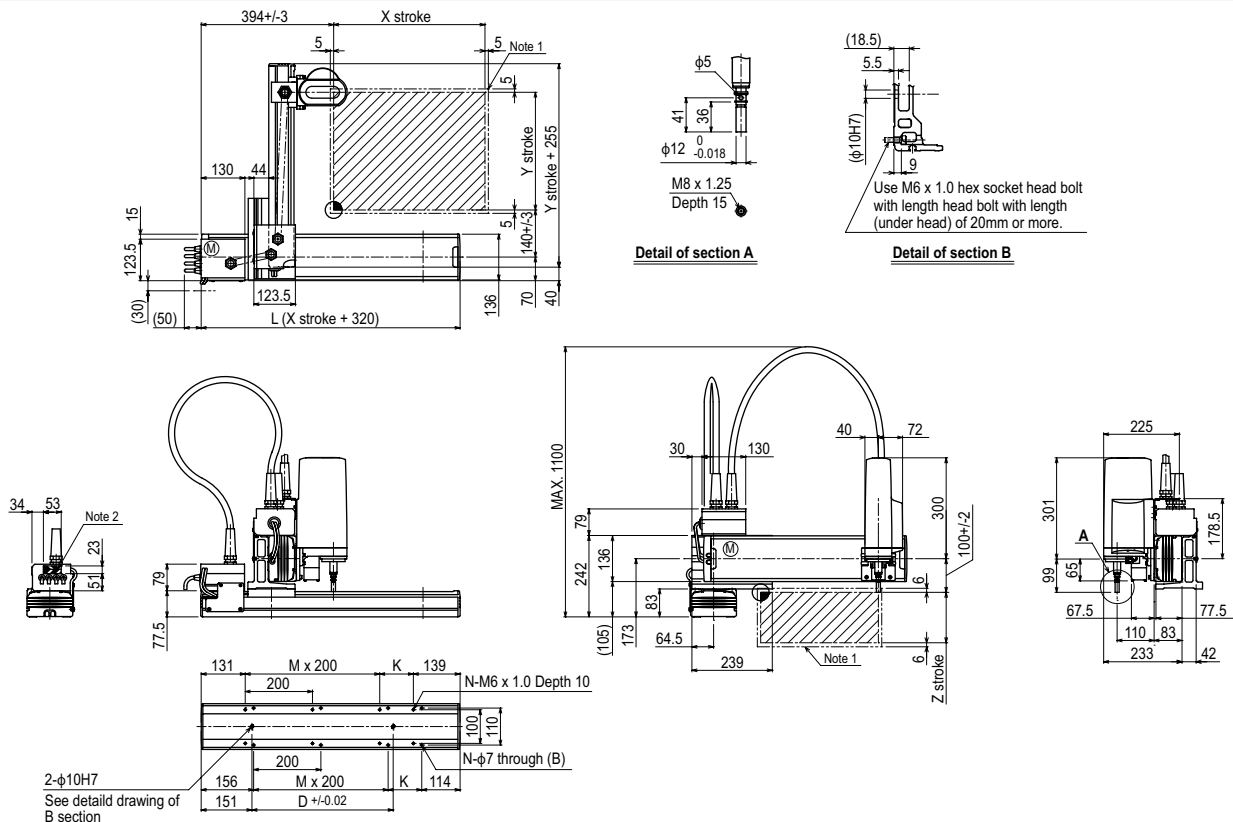

X stroke	150	250	350	450	550	650	750	850	
	L	470	570	670	770	870	970	1070	1170
K	200	100	200	100	200	100	200	100	
D	240	240	420	420	600	600	780	960	
M	0	1	1	2	2	3	3	4	
N	4	6	6	8	8	10	10	12	
Y stroke	150	250	350	450	550	650			
Z stroke	150								
Maximum speed for each stroke (mm/sec) ^{Note 3}	X-axis	1200					960	780	
	Speed setting	-					80%	65%	

Note 1. The moving range when returning to origin and the stop position when stopping by the mechanical stopper.
 Note 2. The shaded position indicates a user cable extraction port.

Note 3. When the X-axis stroke is longer than 750mm, resonance of the ball screw may occur depending on the operation conditions (critical speed). In this case, reduce the speed setting on the program by referring to the maximum speeds shown in the table at the left.

Articulated robots
YA
Linear conveyor modules
LCM100
Motor-less single axis actuator
Robonity
Compact single-axis robots
TRANSEVO
Single-axis robots
FLIP-X
Linear motor single-axis robots
PHASER
Cartesian robots
XX-X
SCARA robots
YK-X
Pick & place robots
YP-X
CLEAN
CONTROLLER INFORMATION
Arm type
Gantry type
Moving arm type
Pole type
XZ type

SXYBx 2 axes

● Arm type ● Cable carrier

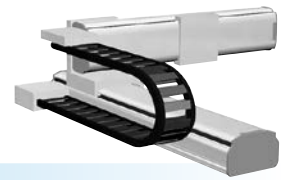

Ordering method

SXYBx - C

Model	Cable	Combination	X-axis stroke	Y-axis stroke	Cable
A1			15 to 305cm	15 to 55cm	3L: 3.5m
A2					5L: 5m
A3					10L: 10m
A4					

RCX320-2

Controller / Number of controllable axes	Safety standard	Regenerative unit	Option A (OP.A)	Option B (OP.B)	Vision System	Absolute battery

Specify various controller setting items. RCX320 ▶ P.548

RCX222

Controller	Usable for CE	Regenerative unit	I/O selection 1	I/O selection 2

Specify various controller setting items. RCX222 ▶ P.558

Note 1. A regenerative unit is required when the maximum speed exceeds 1250mm/sec.

Specification

	X-axis	Y-axis
Axis construction ^{Note 1}	B14H	B14
AC servo motor output (W)	200	100
Repeatability ^{Note 2} (mm)	+/-0.04	+/-0.04
Drive system	Timing belt	Timing belt
Ball screw lead ^{Note 3} (Deceleration ratio) (mm)	Equivalent to lead 25	Equivalent to lead 25
Maximum speed (mm/sec)	1875	1875
Moving range (mm)	150 to 3050	150 to 550
Robot cable length (m)	Standard: 3.5 Option: 5, 10	

Note 1. Use caution that the flame machining (installation holes, tap holes) differs from single-axis robots.
 Note 2. Positioning repeatability in one direction.
 Note 3. Leads not listed in the catalog are also available. Contact us for details.

Maximum payload (kg)

Y stroke (mm)	XY 2 axes
150	14
250	12
350	10
450	8
550	7

Controller

Controller	Operation method
RCX320	Programming / I/O point trace / Remote command / Operation using RS-232C communication
RCX222	

Note. A regenerative unit is required when the maximum speed exceeds 1250mm/sec.

SXYBx 2 axes A1

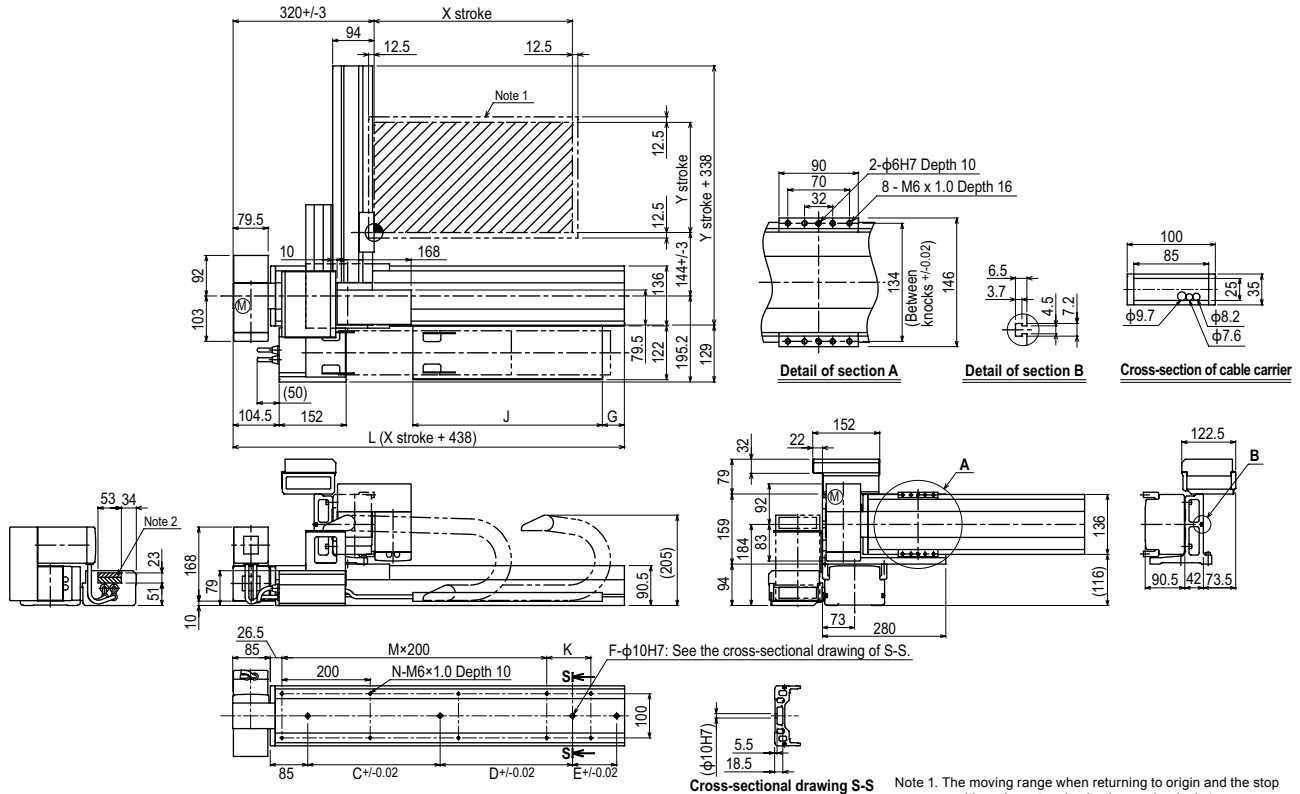

Note 1. The moving range when returning to origin and the stop position when stopping by the mechanical stopper.
 Note 2. The shaded position indicates an user cable extraction port.

X stroke	150	250	350	450	550	650	750	850	950	1050	1150	1250	1350	1450	1550	1650	1750	1850	1950	2050	2150	2250	2350	2450	2550	2650	2750	2850	2950	3050	
L	588	688	788	888	988	1088	1188	1288	1388	1488	1588	1688	1788	1888	1988	2088	2188	2288	2388	2488	2588	2688	2788	2888	2988	3088	3188	3288	3388	3488	
K	200	100	200	100	200	100	200	100	200	100	200	100	200	100	200	100	200	100	200	100	200	100	200	100	200	100	200	100	200	100	200
C	240	420	600	600	780	780	960	960	1140	1140	1140	1140	1140	1140	1140	1140	1140	1140	1140	1140	1140	1140	1140	1140	1140	1140	1140	1140	1140	1140	1140
D	-	-	-	-	-	-	-	-	-	-	240	240	240	420	600	600	780	780	960	960	1140	1140	1140	1140	1140	1140	1140	1140	1140	1140	1140
E	-	-	-	-	-	-	-	-	-	-	-	-	-	-	-	-	-	-	-	-	240	240	420	420	600	600	780	780	960	960	
F	2	2	2	2	2	2	2	2	2	3	3	3	3	3	3	3	3	3	3	3	3	3	3	3	3	3	3	3	3	3	3
M	1	2	2	3	3	4	4	5	5	6	6	7	7	8	8	9	9	10	10	11	11	12	12	13	13	14	14	15	15	16	16
N	6	8	8	10	10	12	12	14	14	16	16	18	18	20	20	22	22	24	24	26	26	28	28	30	30	32	32	34	34	36	36
G	0	50	0	50	0	50	0	50	0	50	0	50	0	50	0	50	0	50	0	50	0	50	0	50	0	50	0	50	0	50	0
J	330	330	430	430	530	530	630	630	730	730	830	830	930	930	1030	1030	1130	1130	1230	1230	1330	1330	1430	1430	1530	1530	1630	1630	1730	1730	
Y stroke	150	250	350	450	550																										

SXYBx 2 axes **A2**

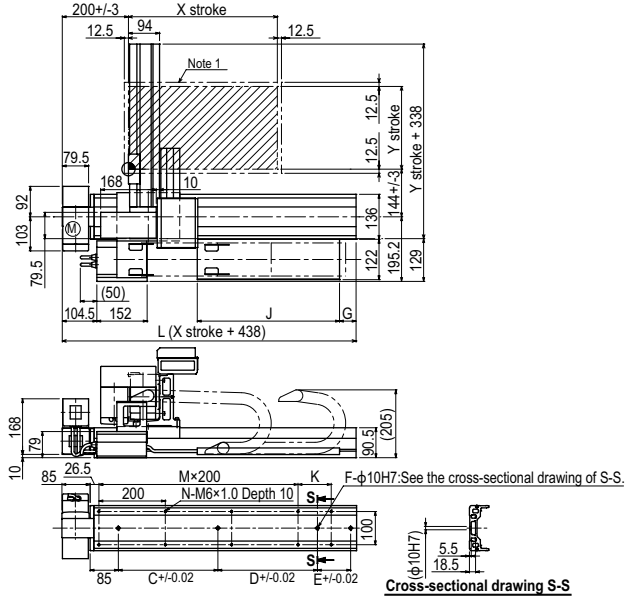
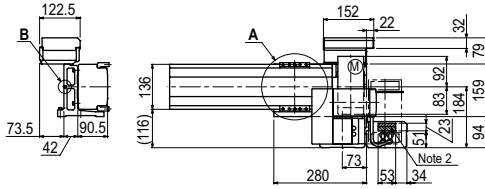
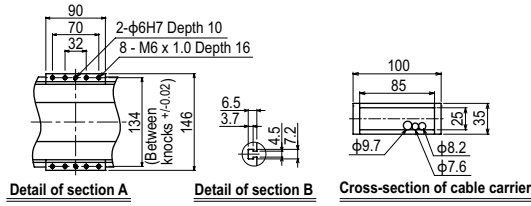

SXYBx 2 axes **A3**

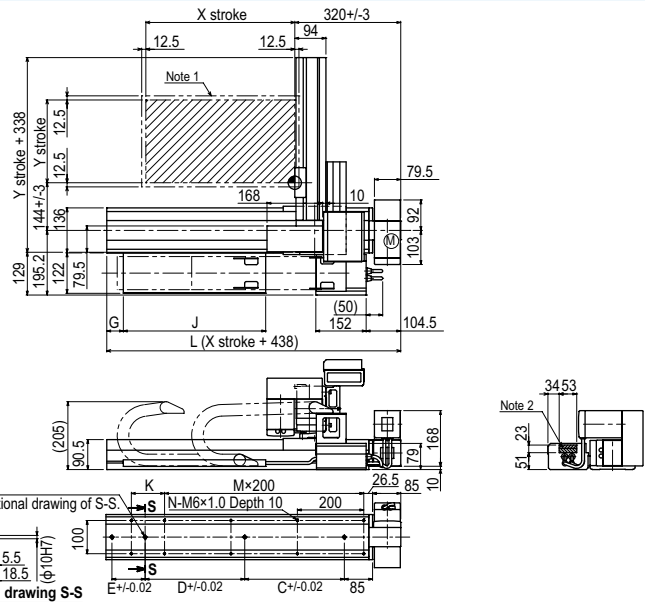
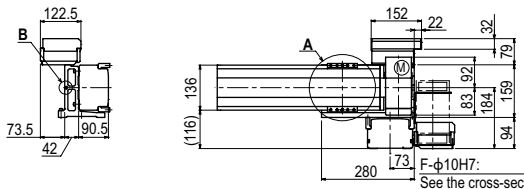
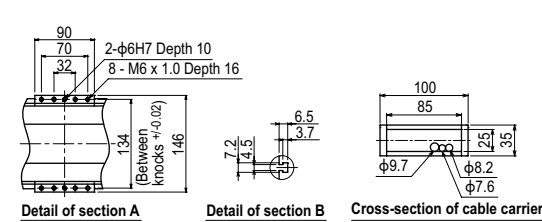

SXYBx 2 axes **A4**

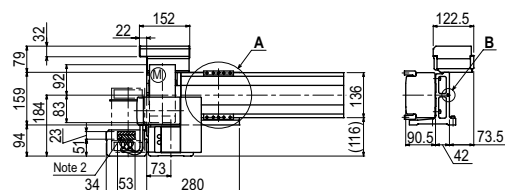
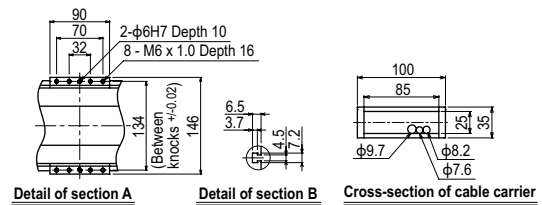
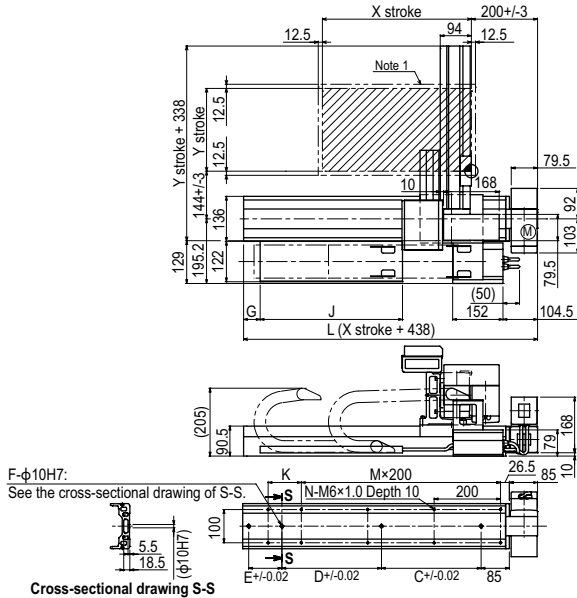

Articulated robots	YA
Linear conveyor modules	LCM100
Motor-less single axis actuator	Robonity
Compact single-axis robots	TRANSEVO
Single-axis robots	FLIP-X
Linear motor single-axis robots	PHASER
Cartesian robots	XX-X
SCARA robots	YK-X
Pick & place robots	YP-X
CLEAN	CLEAN
CONTROLLER	CONTROLLER
INFORMATION	INFORMATION
Arm type	Arm type
Gantry type	Gantry type
Moving arm type	Moving arm type
Pole type	Pole type
XZ type	XZ type

SXYBx 3 axes / ZF

- Arm type
- Cable carrier
- Z-axis: clamped base / moving table type (100W)

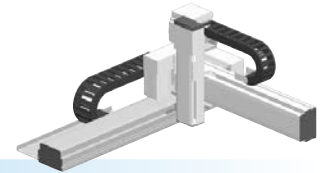

Ordering method

SXYBx - C [] [] [] **ZF** [] [] **RCX340-3** [] [] [] [] [] [] [] [] [] []

Model	Cable	Combination	X-axis stroke	Y-axis stroke	ZR-axis	Z-axis stroke	Cable	Controller / Number of controllable axes	Safety standard	Option A (OP.A)	Option B (OP.B)	Option C (OP.C)	Option D (OP.D)	Option E (OP.E)	Absolute battery
A1		A1	15 to 305cm	15 to 55cm		15 to 35cm	3L: 3.5m 5L: 5m 10L: 10m								

Specify various controller setting items. RCX340 ▶ **P.566**

Specification

	X-axis	Y-axis	Z-axis
Axis construction ^{Note 1}	B14H	B14	F10-BK
AC servo motor output (W)	200	100	100
Repeatability ^{Note 2} (mm)	+/-0.04	+/-0.04	+/-0.01
Drive system	Timing belt	Timing belt	Ball screw φ15
Ball screw lead ^{Note 3} (Deceleration ratio) (mm)	Equivalent to lead 25	Equivalent to lead 25	10
Maximum speed (mm/sec)	1875	1875	600
Moving range (mm)	150 to 3050	150 to 550	150 to 350
Robot cable length (m)	Standard: 3.5 Option: 5, 10		

Note 1. Use caution that the flame machining (installation holes, tap holes) differs from single-axis robots.
 Note 2. Positioning repeatability in one direction.
 Note 3. Leads not listed in the catalog are also available. Contact us for details.

Maximum payload (kg)

Y stroke (mm)	Z stroke (mm)		
	150	250	350
150	8	7	6
250	6	5	4
350	4	3	2
450	2	1	-
550	1	-	-

Controller

Controller	Operation method
RCX340	Programming / I/O point trace / Remote command / Operation using RS-232C communication

SXYBx 3 axes / ZF (A1)

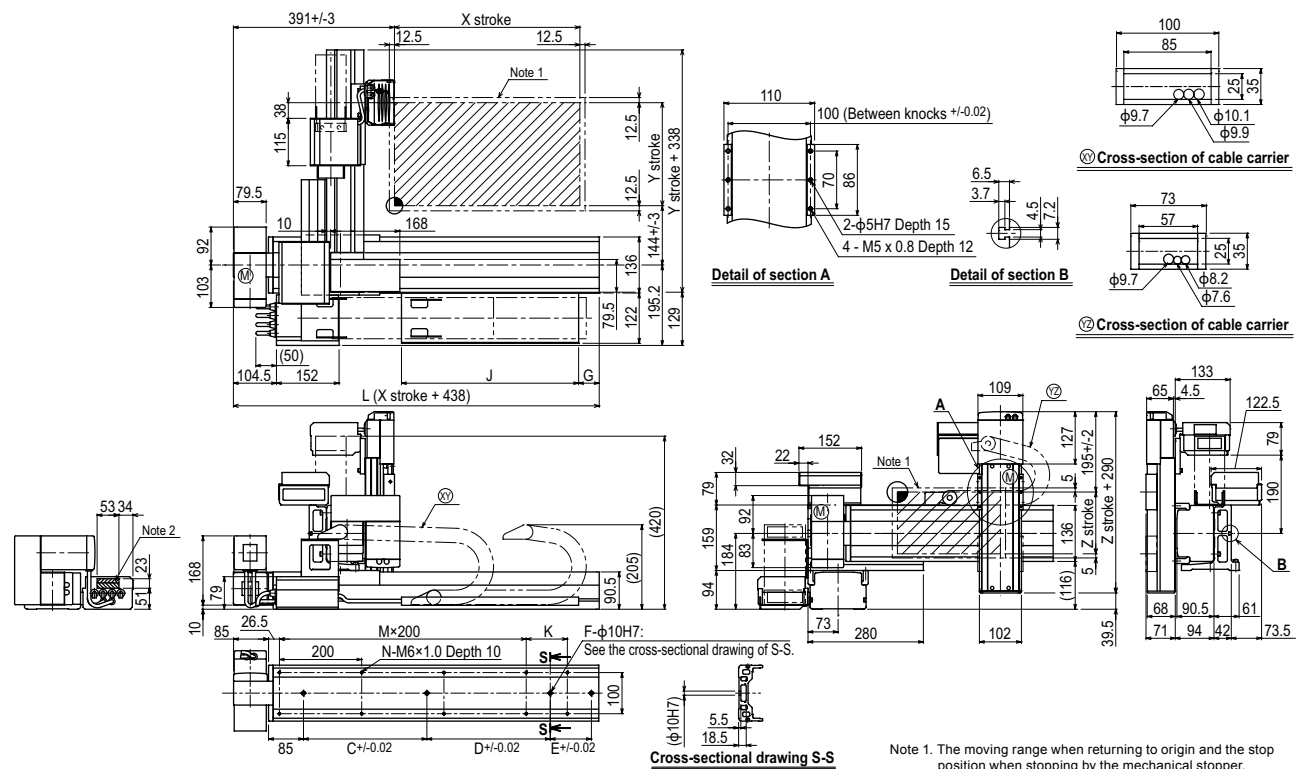

Note 1. The moving range when returning to origin and the stop position when stopping by the mechanical stopper.
 Note 2. The shaded position indicates a user cable extraction port.

X stroke	150	250	350	450	550	650	750	850	950	1050	1150	1250	1350	1450	1550	1650	1750	1850	1950	2050	2150	2250	2350	2450	2550	2650	2750	2850	2950	3050	
L	588	688	788	888	988	1088	1188	1288	1388	1488	1588	1688	1788	1888	1988	2088	2188	2288	2388	2488	2588	2688	2788	2888	2988	3088	3188	3288	3388	3488	
K	200	100	200	100	200	100	200	100	200	100	200	100	200	100	200	100	200	100	200	100	200	100	200	100	200	100	200	100	200	100	200
C	240	420	600	600	780	780	960	960	1140	1140	1140	1140	1140	1140	1140	1140	1140	1140	1140	1140	1140	1140	1140	1140	1140	1140	1140	1140	1140	1140	1140
D	-	-	-	-	-	-	-	-	-	-	240	240	240	420	600	600	780	780	960	960	1140	1140	1140	1140	1140	1140	1140	1140	1140	1140	1140
E	-	-	-	-	-	-	-	-	-	-	-	-	-	-	-	-	-	-	-	-	-	-	240	240	420	420	600	600	780	960	
F	2	2	2	2	2	2	2	2	2	2	3	3	3	3	3	3	3	3	3	3	3	3	3	4	4	4	4	4	4	4	4
M	1	2	2	3	3	4	4	5	5	6	6	7	7	8	8	9	9	10	10	11	11	12	12	13	13	14	14	15	15	16	16
N	6	8	8	10	10	12	12	14	14	16	16	18	18	20	20	22	22	24	24	26	26	28	28	30	30	32	32	34	34	36	
G	0	50	0	50	0	50	0	50	0	50	0	50	0	50	0	50	0	50	0	50	0	50	0	50	0	50	0	50	0	50	0
J	330	330	430	430	530	530	630	630	730	730	830	830	930	930	1030	1030	1130	1130	1230	1230	1330	1330	1430	1430	1530	1530	1630	1630	1730	1730	
Y stroke	150	250	350	450	550																										
Z stroke	150	250	350																												

SXYBx

3 axes / ZFL20

- Arm type
- Cable carrier
- Z-axis: clamped base / moving table type (200W)

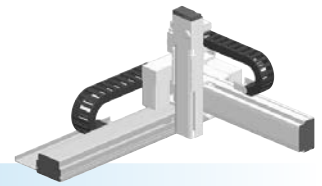

Ordering method

SXYBx - C [] [] [] **ZFL20** [] [] **RCX340-3** [] [] [] [] [] [] [] [] [] []

Model	Cable	Combination	X-axis stroke	Y-axis stroke	ZR-axis	Z-axis stroke	Cable	Controller / Number of controllable axes	Safety standard	Option A (OP.A)	Option B (OP.B)	Option C (OP.C)	Option D (OP.D)	Option E (OP.E)	Absolute battery
A1			15 to 305cm	15 to 45cm		15 to 35cm	3L: 3.5m 5L: 5m 10L: 10m								
A2															
A3															
A4															

Specify various controller setting items. RCX340 ▶ **P.566**

Specification

	X-axis	Y-axis	Z-axis
Axis construction ^{Note 1}	B14H	B14	F10H-BK
AC servo motor output (W)	200	100	200
Repeatability ^{Note 2} (mm)	+/-0.04	+/-0.04	+/-0.01
Drive system	Timing belt	Timing belt	Ball screw φ15
Ball screw lead ^{Note 3} (Deceleration ratio) (mm)	Equivalent to lead 25	Equivalent to lead 25	20
Maximum speed (mm/sec)	1875	1875	1200
Moving range (mm)	150 to 3050	150 to 450	150 to 350
Robot cable length (m)	Standard: 3.5 Option: 5,10		

Note 1. Use caution that the frame machining (installation holes, tap holes) differs from single-axis robots.
 Note 2. Positioning repeatability in one direction.
 Note 3. Leads not listed in the catalog are also available. Contact us for details.

Maximum payload (kg)

Y stroke (mm)	Z stroke (mm)		
	150	250	350
150	7	6	5
250	5	4	3
350	3	2	1
450	1	-	-

Controller

Controller	Operation method
RCX340	Programming / I/O point trace / Remote command / Operation using RS-232C communication

SXYBx 3 axes / ZFL20 (A1)

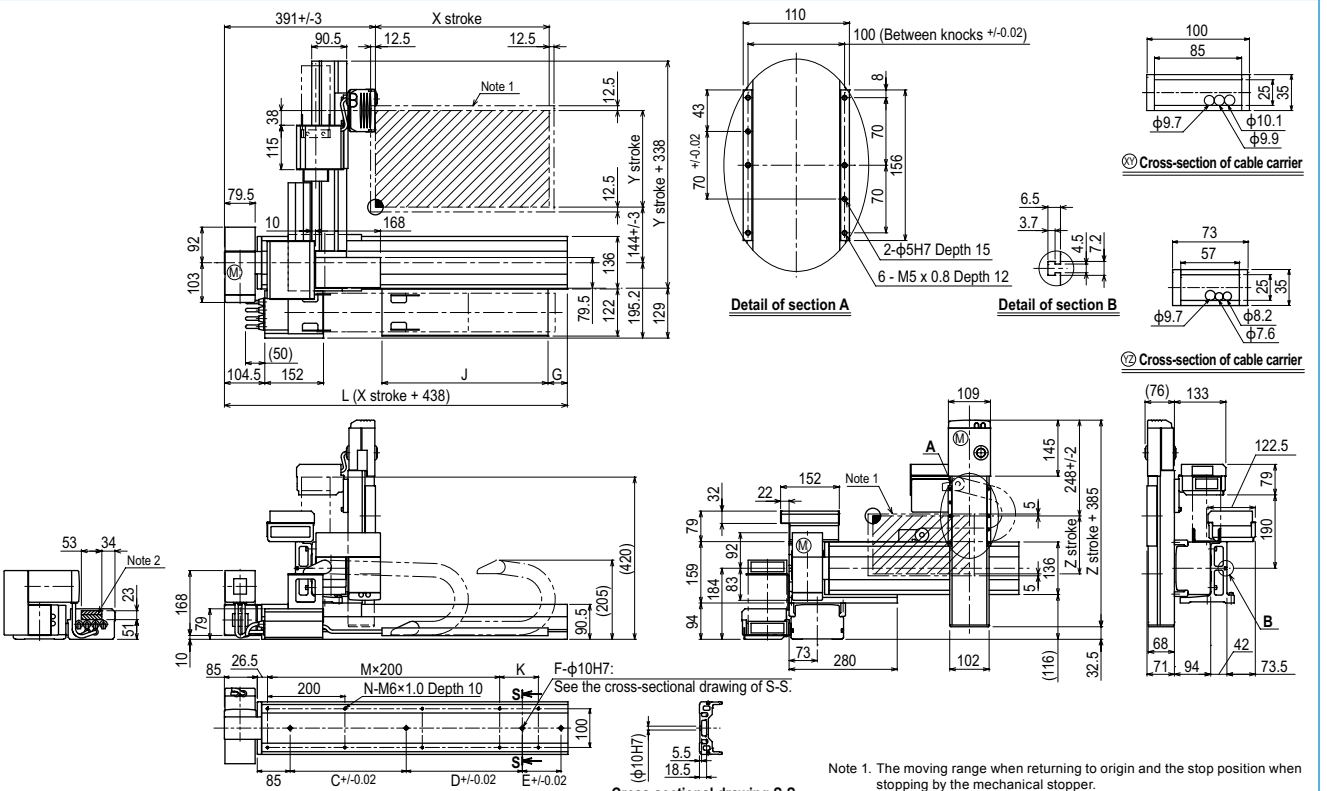

X stroke	150	250	350	450	550	650	750	850	950	1050	1150	1250	1350	1450	1550	1650	1750	1850	1950	2050	2150	2250	2350	2450	2550	2650	2750	2850	2950	3050
L	588	688	788	888	988	1088	1188	1288	1388	1488	1588	1688	1788	1888	1988	2088	2188	2288	2388	2488	2588	2688	2788	2888	2988	3088	3188	3288	3388	3488
K	200	100	200	100	200	100	200	100	200	100	200	100	200	100	200	100	200	100	200	100	200	100	200	100	200	100	200	100	200	100
C	240	420	600	600	780	780	960	960	1140	1140	1140	1140	1140	1140	1140	1140	1140	1140	1140	1140	1140	1140	1140	1140	1140	1140	1140	1140	1140	1140
D	-	-	-	-	-	-	-	-	-	-	240	240	240	420	600	600	780	780	960	960	1140	1140	1140	1140	1140	1140	1140	1140	1140	1140
E	-	-	-	-	-	-	-	-	-	-	-	-	-	-	-	-	-	-	-	-	-	-	-	-	-	-	-	-	-	-
F	2	2	2	2	2	2	2	2	2	2	3	3	3	3	3	3	3	3	3	3	3	3	4	4	4	4	4	4	4	4
M	1	2	2	3	3	4	4	5	5	6	6	7	7	8	8	9	9	10	10	11	11	12	12	13	13	14	14	15	15	16
N	6	8	8	10	10	12	12	14	14	16	16	18	18	20	20	22	22	24	24	26	26	28	28	30	30	32	32	34	34	36
G	0	50	0	50	0	50	0	50	0	50	0	50	0	50	0	50	0	50	0	50	0	50	0	50	0	50	0	50	0	50
J	330	330	430	430	530	530	630	630	730	730	830	830	930	930	1030	1030	1130	1130	1230	1230	1330	1330	1430	1430	1530	1530	1630	1630	1730	1730
Y stroke	150	250	350	450																										
Z stroke	150	250	350																											

SXYBx

3 axes / ZFH

- Arm type
- Cable carrier
- Z-axis: clamped table / moving base type (200W)

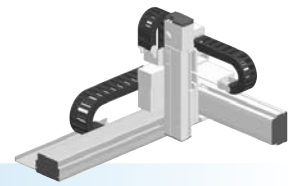

Ordering method

SXYBx - C **ZFH** **RCX340-3**

Model	Cable	Combination	X-axis stroke	Y-axis stroke	ZR-axis	Z-axis stroke	Cable	Controller / Number of controllable axes	Safety standard	Option A (OP.A)	Option B (OP.B)	Option C (OP.C)	Option D (OP.D)	Option E (OP.E)	Absolute battery
A1			15 to 305cm	15 to 45cm		15 to 35cm	3L: 3.5m 5L: 5m 10L: 10m								

Specify various controller setting items. RCX340 ▶ **P.566**

Specification

	X-axis	Y-axis	Z-axis
Axis construction <small>Note 1</small>	B14H	B14	F10H-BK
AC servo motor output (W)	200	100	200
Repeatability <small>Note 2</small> (mm)	+/-0.04	+/-0.04	+/-0.01
Drive system	Timing belt	Timing belt	Ball screw φ15
Ball screw lead <small>Note 3</small> (Deceleration ratio) (mm)	Equivalent to lead 25	Equivalent to lead 25	10
Maximum speed (mm/sec)	1875	1875	600
Moving range (mm)	150 to 3050	150 to 450	150 to 350
Robot cable length (m)	Standard: 3.5 Option: 5,10		

Note 1. Use caution that the frame machining (installation holes, tap holes) differs from single-axis robots.
 Note 2. Positioning repeatability in one direction.
 Note 3. Leads not listed in the catalog are also available. Contact us for details.

Maximum payload (kg)

Y stroke (mm)	Z stroke (mm)		
	150	250	350
150	7	6	5
250	5	4	3
350	3	2	1
450	1	-	-

Controller

Controller	Operation method
RCX340	Programming / I/O point trace / Remote command / Operation using RS-232C communication

SXYBx 3 axes / ZFH (A1)

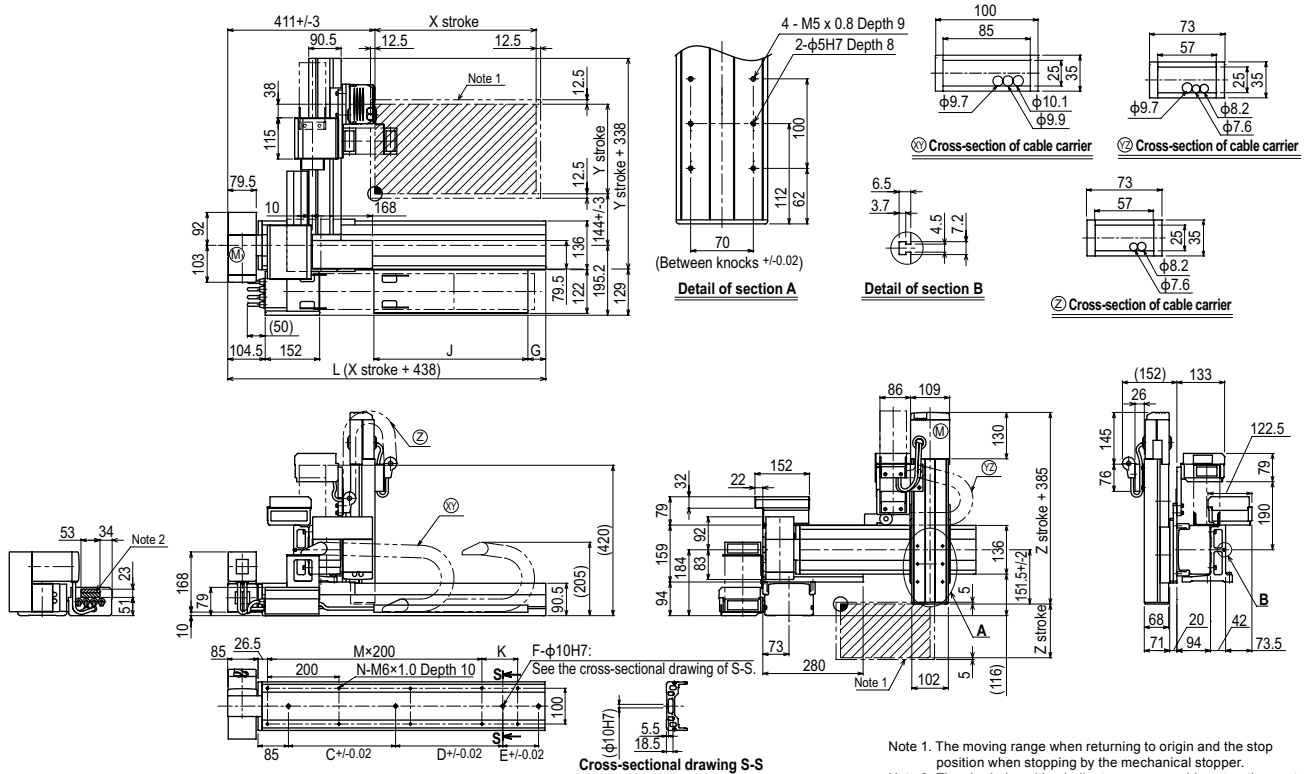

Note 1. The moving range when returning to origin and the stop position when stopping by the mechanical stopper.
 Note 2. The shaded position indicates an user cable extraction port.

X stroke	150	250	350	450	550	650	750	850	950	1050	1150	1250	1350	1450	1550	1650	1750	1850	1950	2050	2150	2250	2350	2450	2550	2650	2750	2850	2950	3050							
L	588	688	788	888	988	1088	1188	1288	1388	1488	1588	1688	1788	1888	1988	2088	2188	2288	2388	2488	2588	2688	2788	2888	2988	3088	3188	3288	3388	3488							
K	200	100	200	100	200	100	200	100	200	100	200	100	200	100	200	100	200	100	200	100	200	100	200	100	200	100	200	100	200	100	200						
C	240	420	600	600	780	780	960	960	1140	1140	1140	1140	1140	1140	1140	1140	1140	1140	1140	1140	1140	1140	1140	1140	1140	1140	1140	1140	1140	1140	1140						
D	-	-	-	-	-	-	-	-	-	-	240	240	240	420	600	600	780	780	960	960	1140	1140	1140	1140	1140	1140	1140	1140	1140	1140	1140						
E	-	-	-	-	-	-	-	-	-	-	-	-	-	-	-	-	-	-	-	-	-	-	240	240	420	420	600	600	780	960							
F	2	2	2	2	2	2	2	2	2	2	3	3	3	3	3	3	3	3	3	3	3	3	3	4	4	4	4	4	4	4	4						
M	1	2	2	3	3	4	4	5	5	6	6	7	7	8	8	9	9	10	10	11	11	12	12	13	13	14	14	15	15	16							
N	6	8	8	10	10	12	12	14	14	16	16	18	18	20	20	22	22	24	24	26	26	28	28	30	30	32	32	34	34	36							
G	0	50	0	50	0	50	0	50	0	50	0	50	0	50	0	50	0	50	0	50	0	50	0	50	0	50	0	50	0	50	0						
J	330	330	430	430	530	530	630	630	730	730	830	830	930	930	1030	1030	1130	1130	1230	1230	1330	1330	1430	1430	1530	1530	1630	1630	1730	1730							
Y stroke	150	250	350	450																																	
Z stroke	150	250	350																																		

SXYBx 3 axes / ZS

● Arm type ● Cable carrier ● Z-axis shaft vertical type

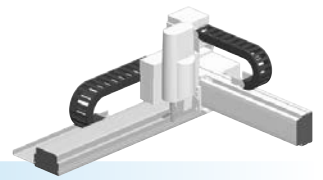

Ordering method

SXYBx - C [] [] [] **ZS - 15** [] **RCX340-3** [] [] [] [] [] [] [] [] []

Model	Cable	Combination	X-axis stroke	Y-axis stroke	ZR-axis	Z-axis stroke	Cable	Controller / Number of controllable axes	Safety standard	Option A (OP.A)	Option B (OP.B)	Option C (OP.C)	Option D (OP.D)	Option E (OP.E)	Absolute battery
		A1	15 to 305cm	15 to 55cm	ZS12		3L: 3.5m 5L: 5m 10L: 10m								

Specify various controller setting items. RCX340 ▶ **P.566**

Specification

	X-axis	Y-axis	Z-axis: ZS12	Z-axis: ZS6
Axis construction ^{Note 1}	B14H	B14	-	
AC servo motor output (W)	200	100	60	
Repeatability ^{Note 2} (mm)	+/-0.04	+/-0.04	+/-0.02	
Drive system	Timing belt	Timing belt	Ball screw ϕ 12	
Ball screw lead ^{Note 3} (Deceleration ratio) (mm)	Equivalent to lead 25	Equivalent to lead 25	12	6
Maximum speed (mm/sec)	1875	1875	1000	500
Moving range (mm)	150 to 3050	150 to 550	150	
Robot cable length (m)	Standard: 3.5 Option: 5,10			

Note 1. Use caution that the flame machining (installation holes, tap holes) differs from single-axis robots.
 Note 2. Positioning repeatability in one direction.
 Note 3. Leads not listed in the catalog are also available. Contact us for details.

Maximum payload (kg)

Y stroke (mm)	ZS12	ZS6
150	3	5
250	3	5
350	3	5
450	3	4
550	3	3

Controller

Controller	Operation method
RCX340	Programming / I/O point trace / Remote command / Operation using RS-232C communication

SXYBx 3 axes / ZS A1

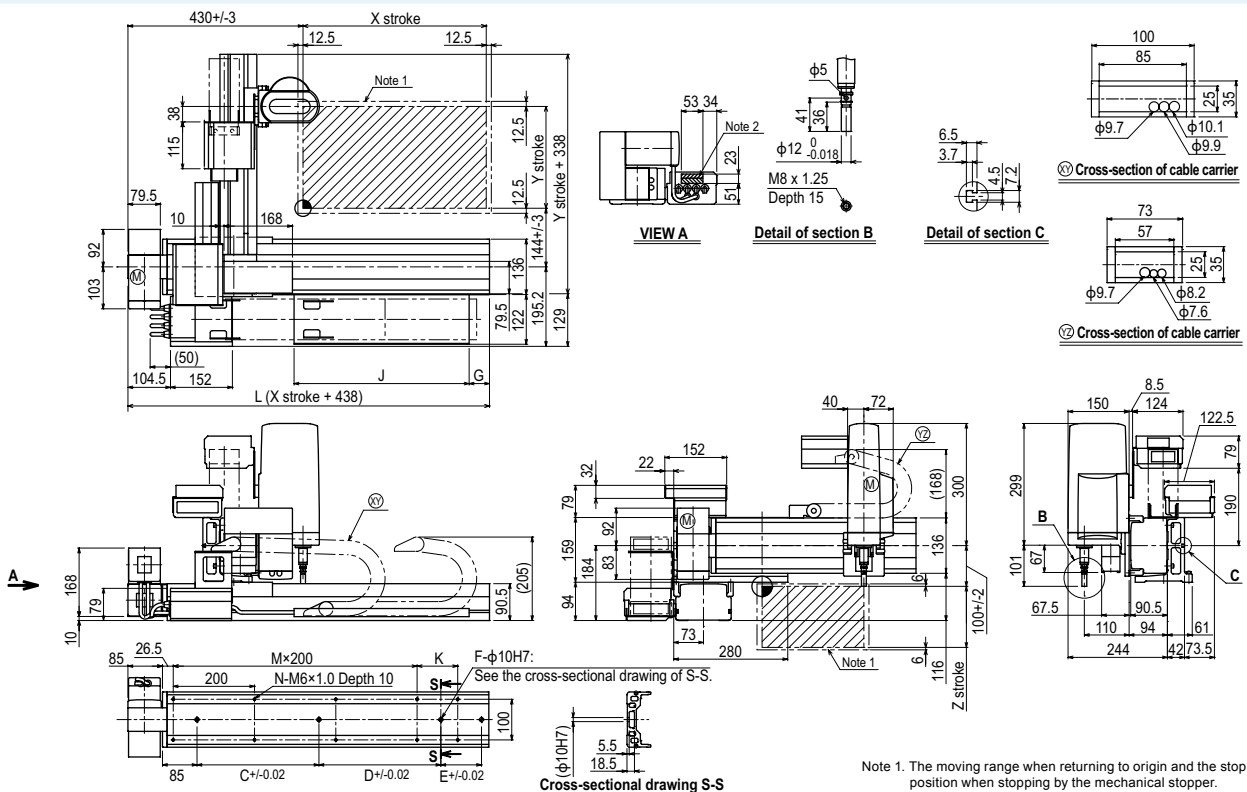

Note 1. The moving range when returning to origin and the stop position when stopping by the mechanical stopper.
 Note 2. The shaded position indicates an user cable extraction port.

X stroke	150	250	350	450	550	650	750	850	950	1050	1150	1250	1350	1450	1550	1650	1750	1850	1950	2050	2150	2250	2350	2450	2550	2650	2750	2850	2950	3050						
L	588	688	788	888	988	1088	1188	1288	1388	1488	1588	1688	1788	1888	1988	2088	2188	2288	2388	2488	2588	2688	2788	2888	2988	3088	3188	3288	3388	3488						
K	200	100	200	100	200	100	200	100	200	100	200	100	200	100	200	100	200	100	200	100	200	100	200	100	200	100	200	100	200	100						
C	240	420	600	600	780	780	960	960	1140	1140	1140	1140	1140	1140	1140	1140	1140	1140	1140	1140	1140	1140	1140	1140	1140	1140	1140	1140	1140	1140						
D	-	-	-	-	-	-	-	-	-	-	240	240	240	420	600	600	780	780	960	960	1140	1140	1140	1140	1140	1140	1140	1140	1140	1140						
E	-	-	-	-	-	-	-	-	-	-	-	-	-	-	-	-	-	-	-	-	-	-	-	240	240	420	420	600	600	780	960					
F	2	2	2	2	2	2	2	2	2	2	3	3	3	3	3	3	3	3	3	3	3	3	3	4	4	4	4	4	4	4						
M	1	2	2	3	3	4	4	5	5	6	6	7	7	8	8	9	9	10	10	11	11	12	12	13	13	14	14	15	15	16						
N	6	8	8	10	10	12	12	14	14	16	16	18	18	20	20	22	22	24	24	26	26	28	28	30	30	32	32	34	34	36						
G	0	50	0	50	0	50	0	50	0	50	0	50	0	50	0	50	0	50	0	50	0	50	0	50	0	50	0	50	0	50						
J	330	330	430	430	530	530	630	630	730	730	830	830	930	930	1030	1030	1130	1130	1230	1230	1330	1330	1430	1430	1530	1530	1630	1630	1730	1730						
Y stroke	150	250	350	450	550																															
Z stroke	150																																			

SXYBx 4 axes / ZRS

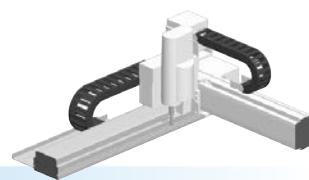

- Arm type
- Cable carrier
- ZR axis integrated type

Ordering method

SXYBx - C [] [] [] [] **15** [] **RCX340-4** [] [] [] [] [] [] [] [] [] [] [] [] [] [] []

Model	Cable	Combination	X-axis stroke	Y-axis stroke	ZR-axis	Z-axis stroke	Cable	Controller / Number of controllable axes	Safety standard	Option A (OP.A)	Option B (OP.B)	Option C (OP.C)	Option D (OP.D)	Option E (OP.E)	Absolute battery
		A1	15 to 305cm	15 to 55cm	ZRS12		3L: 3.5m 5L: 5m 10L: 10m								

Specify various controller setting items. RCX340 ▶ **P.566**

Specification

	X-axis	Y-axis	Z-axis: ZRS12	Z-axis: ZRS6	R-axis
Axis construction ^{Note 1}	B14H	B14	-	-	-
AC servo motor output (W)	200	100	60	100	
Repeatability ^{Note 2} (XYZ: mm)(R: °)	+/-0.04	+/-0.04	+/-0.02	+/-0.005	
Drive system	Timing belt	Timing belt	Ball screw φ12	Harmonic gear	
Ball screw lead ^{Note 3} (Deceleration ratio) (mm)	Equivalent to lead 25	Equivalent to lead 25	12	6	(1/50)
Maximum speed (XYZ: mm/sec)(R: °/sec)	1875	1875	1000	500	1020
Moving range (XYZ: mm)(R: °)	150 to 3050	150 to 550	150		360
Robot cable length (m)	Standard: 3.5 Option: 5.10				

Note 1. Use caution that the flame machining (installation holes, tap holes) differs from single-axis robots.
 Note 2. Positioning repeatability in one direction.
 Note 3. Leads not listed in the catalog are also available. Contact us for details.

Maximum payload (kg)

Y stroke (mm)	ZRS12	ZRS6
150	3	5
250	3	5
350	3	5
450	3	3
550	2	2

Controller

Controller	Operation method
RCX340	Programming / I/O point trace / Remote command / Operation using RS-232C communication

SXYBx 4 axes / ZRS A1

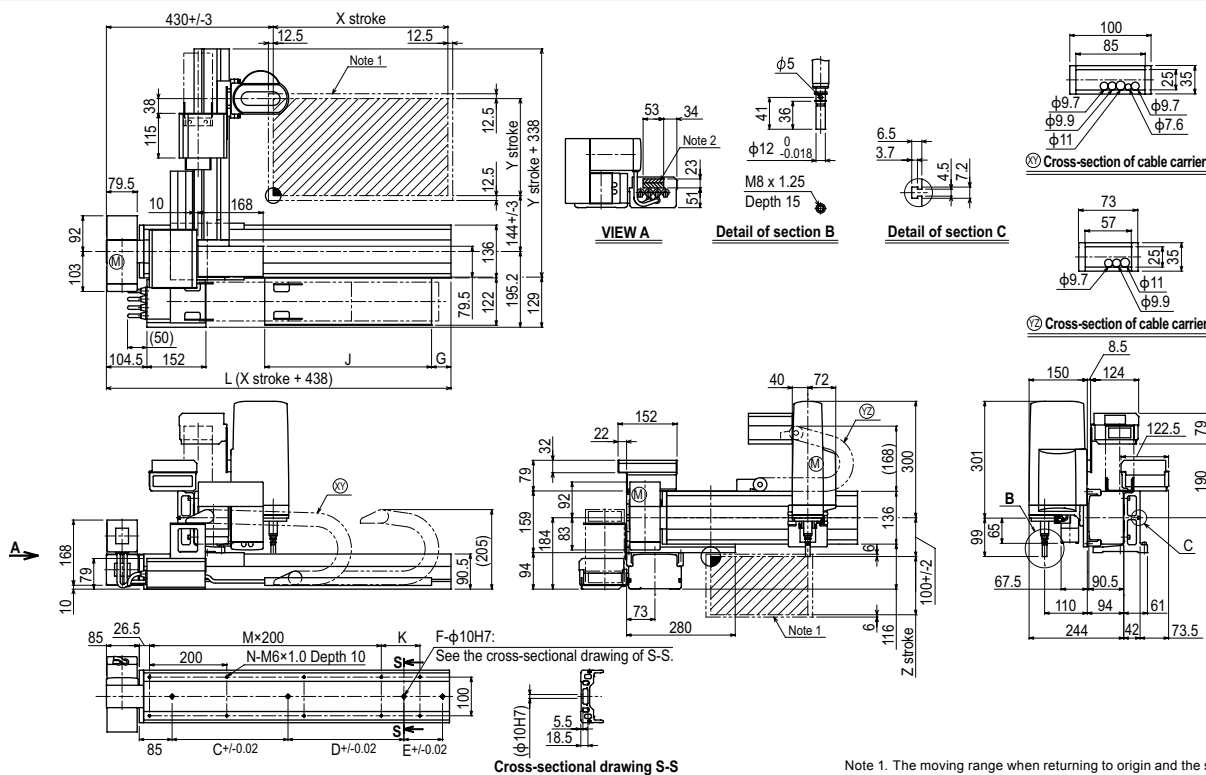

Note 1. The moving range when returning to origin and the stop position when stopping by the mechanical stopper.
 Note 2. The shaded position indicates an user cable extraction port.

	150	250	350	450	550	650	750	850	950	1050	1150	1250	1350	1450	1550	1650	1750	1850	1950	2050	2150	2250	2350	2450	2550	2650	2750	2850	2950	3050	
X stroke	150	250	350	450	550	650	750	850	950	1050	1150	1250	1350	1450	1550	1650	1750	1850	1950	2050	2150	2250	2350	2450	2550	2650	2750	2850	2950	3050	
L	588	688	788	888	988	1088	1188	1288	1388	1488	1588	1688	1788	1888	1988	2088	2188	2288	2388	2488	2588	2688	2788	2888	2988	3088	3188	3288	3388	3488	
K	200	100	200	100	200	100	200	100	200	100	200	100	200	100	200	100	200	100	200	100	200	100	200	100	200	100	200	100	200	100	
C	240	420	600	600	780	780	960	960	1140	1140	1140	1140	1140	1140	1140	1140	1140	1140	1140	1140	1140	1140	1140	1140	1140	1140	1140	1140	1140	1140	1140
D	-	-	-	-	-	-	-	-	-	-	240	240	240	420	600	600	780	780	960	960	1140	1140	1140	1140	1140	1140	1140	1140	1140	1140	1140
E	-	-	-	-	-	-	-	-	-	-	-	-	-	-	-	-	-	-	-	-	-	-	240	240	420	420	600	600	780	960	
F	2	2	2	2	2	2	2	2	2	2	3	3	3	3	3	3	3	3	3	3	3	3	3	4	4	4	4	4	4	4	4
M	1	2	2	3	3	4	4	5	5	6	6	7	7	8	8	9	9	10	10	11	11	12	12	13	13	14	14	15	15	16	
N	6	8	8	10	10	12	12	14	14	16	16	18	18	20	20	22	22	24	24	26	26	28	28	30	30	32	32	34	34	36	
G	0	50	0	50	0	50	0	50	0	50	0	50	0	50	0	50	0	50	0	50	0	50	0	50	0	50	0	50	0	50	
J	330	330	430	430	530	530	630	630	730	730	830	830	930	930	1030	1030	1130	1130	1230	1230	1330	1330	1430	1430	1530	1530	1630	1630	1730	1730	
Y stroke	150	250	350	450	550																										
Z stroke	150																														

Articulated robots
YA

Linear conveyor
modules
LCM100

Motor-less single
axis actuator
Robonity

Compact
single-axis robots
TRANSERVO

Single-axis robots
FLIP-X

Linear motor
single-axis robots
PHASER

Cartesian
robots
XY-X

SCARA
robots
YK-X

Pick & place
robots
YP-X

CLEAN

CONTROLLER

INFORMATION

Arm type

Gantry type

Moving arm
type

Pole type

XZ type

NXY 2 axes

● Arm type ● Cable carrier



Ordering method

NXY - C

Model	Cable	Combination	X-axis stroke	Y-axis stroke	Cable
A1			50 to 200cm	15 to 65cm	3L: 3.5m 5L: 5m 10L: 10m
A3					

RCX320-2 **R**

Controller / Number of controllable axes	Safety standard	Regenerative unit	Option A (OP.A)	Option B (OP.B)	Vision System	Absolute battery
--	-----------------	-------------------	-----------------	-----------------	---------------	------------------

Specify various controller setting items. RCX320 ▶ **P.548**

RCX222 **R**

Controller	Usable for CE	Regenerative unit	I/O selection 1	I/O selection 2
------------	---------------	-------------------	-----------------	-----------------

Specify various controller setting items. RCX222 ▶ **P.558**

Specification

	X-axis	Y-axis
Axis construction ^{Note 1}	N15	F14
AC servo motor output (W)	400	100
Repeatability ^{Note 2} (mm)	+/-0.01	+/-0.01
Drive system	Ball screw φ15	Ball screw φ15
Ball screw lead ^{Note 3} (Deceleration ratio) (mm)	20	20
Maximum speed (mm/sec)	1200	1200
Moving range (mm)	500 to 2000	150 to 650
Robot cable length (m)	Standard: 3.5 Option: 5,10	

Note 1. Use caution that the flame machining (installation holes, tap holes) differs from single-axis robots.
 Note 2. Positioning repeatability in one direction.
 Note 3. Leads not listed in the catalog are also available. Contact us for details.

Maximum payload (kg)

Y stroke (mm)	XY 2 axes
150	25
250	21
350	18
450	16
550	13
650	11

Controller

Controller	Operation method
RCX320-R	Programming / I/O point trace / Remote command / Operation using RS-232C communication
RCX222-R	

NXY 2 axes A1

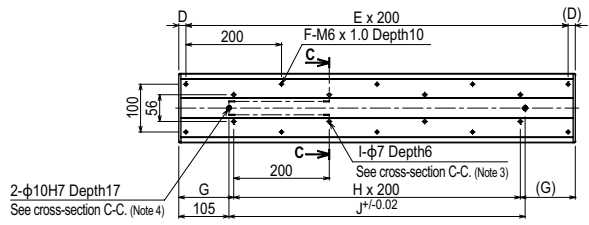
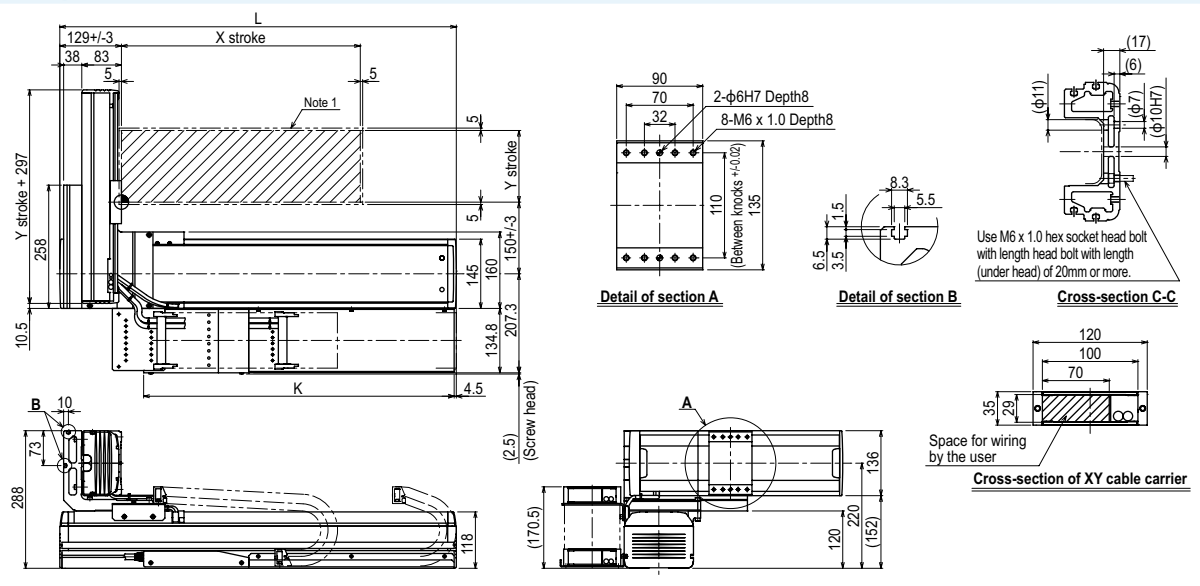

X stroke	500	600	700	800	900	1000	1100	1200	1300	1400	1500	1600	1700	1800	1900	2000
L	830	930	1030	1130	1230	1330	1430	1530	1630	1730	1830	1930	2030	2130	2230	2330
D	15	65	15	65	15	65	15	65	15	65	15	65	15	65	15	65
E	4	4	5	5	6	6	7	7	8	8	9	9	10	10	11	11
F	10	10	12	12	14	14	16	16	18	18	20	20	22	22	24	24
G	115	165	115	165	115	165	115	165	115	165	115	165	115	165	115	165
H	3	3	4	4	5	5	6	6	7	7	8	8	9	9	10	10
I	8	8	10	10	12	12	14	14	16	16	18	18	20	20	22	22
J	620	720	820	920	1020	1120	1220	1320	1420	1520	1620	1720	1820	1920	2020	2120
K	650	700	750	800	850	900	950	1000	1050	1100	1150	1200	1250	1300	1350	1400
Y stroke	150	250	350	450	550	650										

Note 1. The moving range when returning to origin and the stop position when stopping by the mechanical stopper.
 Note 2. The origin of the X axis is set originally as the drawing and it is possible to change it to the R side origin by changing parameters.
 Note 3. When using φ7 holes for installation, you must not use a washer, spring washer, etc. in the main unit.
 Note 4. When using a φ10H7 hole, make sure that the pin does not go into deeper than as shown in the drawing.
 Note 5. Use M4 tap of the box next to X axis for the user grounding terminal.
 Note 6. The M4 taps at both ends of the cable carriage can be used for fixing cables.

NXY 2 axes **A3**

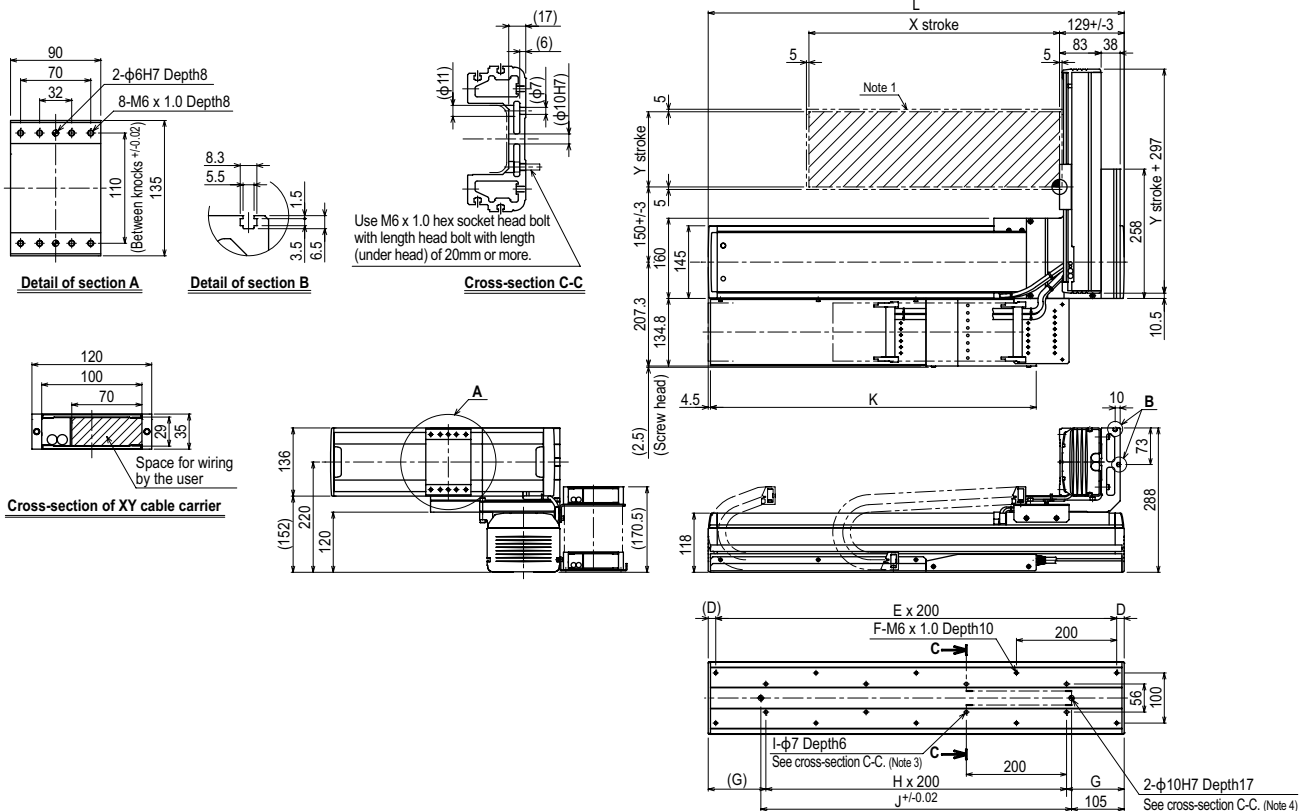

X stroke	500	600	700	800	900	1000	1100	1200	1300	1400	1500	1600	1700	1800	1900	2000
L	830	930	1030	1130	1230	1330	1430	1530	1630	1730	1830	1930	2030	2130	2230	2330
D	15	65	15	65	15	65	15	65	15	65	15	65	15	65	15	65
E	4	4	5	5	6	6	7	7	8	8	9	9	10	10	11	11
F	10	10	12	12	14	14	16	16	18	18	20	20	22	22	24	24
G	115	165	115	165	115	165	115	165	115	165	115	165	115	165	115	165
H	3	3	4	4	5	5	6	6	7	7	8	8	9	9	10	10
I	8	8	10	10	12	12	14	14	16	16	18	18	20	20	22	22
J	620	720	820	920	1020	1120	1220	1320	1420	1520	1620	1720	1820	1920	2020	2120
K	650	700	750	800	850	900	950	1000	1050	1100	1150	1200	1250	1300	1350	1400
Y stroke	150	250	350	450	550	650										

- Note 1. The moving range when returning to origin and the stop position when stopping by the mechanical stopper.
- Note 2. The origin of the X axis is set originally as the drawing and it is possible to change it to the R side origin by changing parameters.
- Note 3. When using φ7 holes for installation, you must not use a washer, spring washer, etc. in the main unit.
- Note 4. When using a φ10H7 hole, make sure that the pin does not go into deeper than as shown in the drawing.
- Note 5. Use M4 tap of the box next to X axis for the user grounding terminal.
- Note 6. The M4 taps at both ends of the cable carriage can be used for fixing cables.

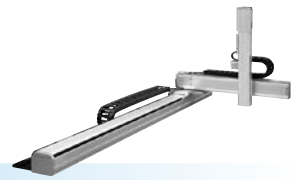

● Arm type ● Cable carrier ● Z-axis: clamped base / moving table type (200W)

Ordering method

NXY - C **ZFL20** **RCX340-3**

Model	Cable	Combination	X-axis stroke	Y-axis stroke	ZR-axis	Z-axis stroke	Cable	Controller / Number of controllable axes	Safety standard	Option A (OP.A)	Option B (OP.B)	Option C (OP.C)	Option D (OP.D)	Option E (OP.E)	Absolute battery
A1	A3	A1	50 to 200cm	15 to 65cm		15 to 35cm	3L: 3.5m 5L: 5m 10L: 10m								

Specify various controller setting items. RCX340 ▶ **P.566**

Specification

	X-axis	Y-axis	Z-axis
Axis construction <small>Note 1</small>	N15	F14	F10H-BK
AC servo motor output (W)	400	100	200
Repeatability <small>Note 2</small> (mm)	+/-0.01	+/-0.01	+/-0.01
Drive system	Ball screw φ15	Ball screw φ15	Ball screw φ15
Ball screw lead <small>Note 3</small> (Deceleration ratio) (mm)	20	20	20
Maximum speed (mm/sec)	1200	1200	1200
Moving range (mm)	500 to 2000	150 to 650	150 to 350
Robot cable length (m)	Standard: 3.5 Option: 5,10		

Note 1. Use caution that the flame machining (installation holes, tap holes) differs from single-axis robots'.
 Note 2. Positioning repeatability in one direction.
 Note 3. Leads not listed in the catalog are also available. Contact us for details.

Maximum payload (kg)

Y stroke (mm)	Z stroke (mm)		
	150	250	350
150	8	8	8
250	8	8	8
350	8	8	8
450	8	7	6
550	5	4	3
650	3	2	1

Controller

Controller	Operation method
RCX340	Programming / I/O point trace / Remote command / Operation using RS-232C communication

NXY 3 axes / ZFL20 (A1)

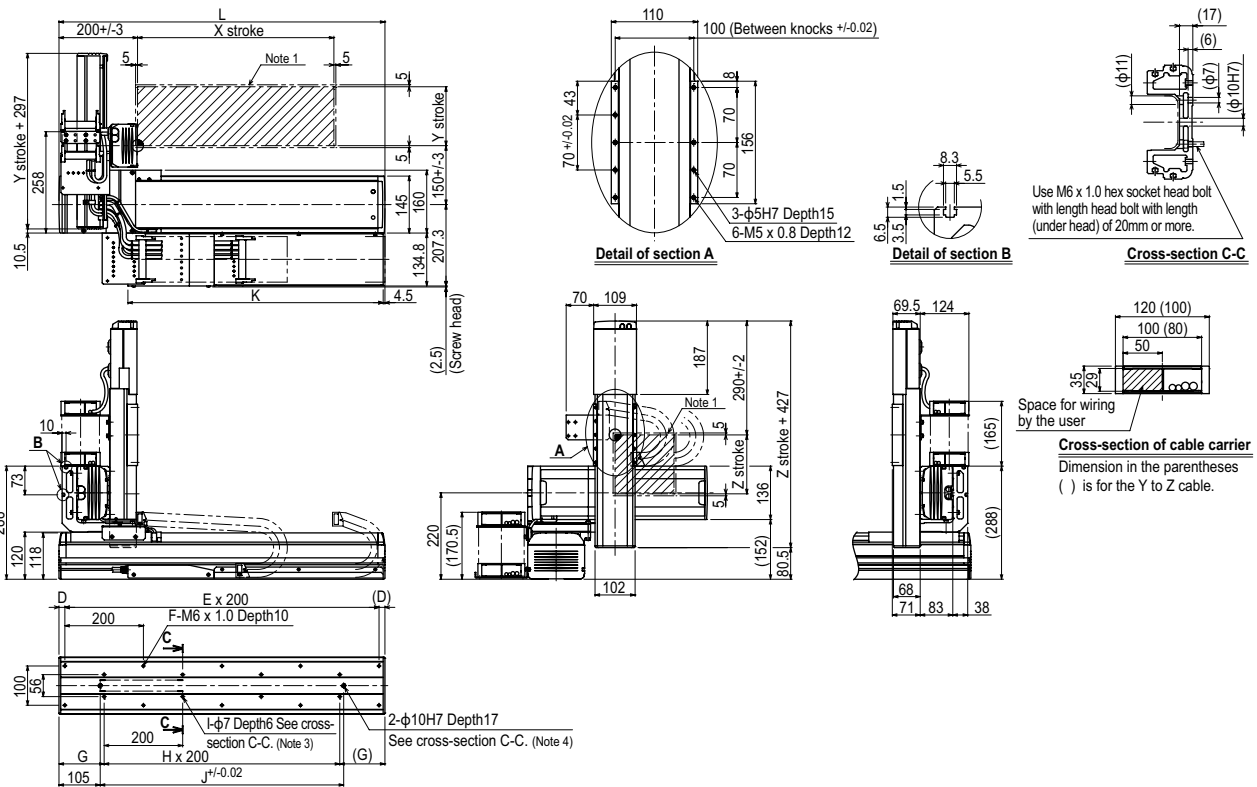

X stroke	500	600	700	800	900	1000	1100	1200	1300	1400	1500	1600	1700	1800	1900	2000
L	830	930	1030	1130	1230	1330	1430	1530	1630	1730	1830	1930	2030	2130	2230	2330
D	15	65	15	65	15	65	15	65	15	65	15	65	15	65	15	65
E	4	4	5	5	6	6	7	7	8	8	9	9	10	10	11	11
F	10	10	12	12	14	14	16	16	18	18	20	20	22	22	24	24
G	115	165	115	165	115	165	115	165	115	165	115	165	115	165	115	165
H	3	3	4	4	5	5	6	6	7	7	8	8	9	9	10	10
I	8	8	10	10	12	12	14	14	16	16	18	18	20	20	22	22
J	620	720	820	920	1020	1120	1220	1320	1420	1520	1620	1720	1820	1920	2020	2120
K	650	700	750	800	850	900	950	1000	1050	1100	1150	1200	1250	1300	1350	1400
Y stroke	150	250	350	450	550	650										
Z stroke	150	250	350													

Note 1. The moving range when returning to origin and the stop position when stopping by the mechanical stopper.
 Note 2. The origin of the X axis is set originally as the drawing and it is possible to change it to the R side origin by changing parameters.
 Note 3. When using φ7 holes for installation, you must not use a washer, spring washer, etc. in the main unit.
 Note 4. When using a φ10H7 hole, make sure that the pin does not go into deeper than as shown in the drawing.
 Note 5. Use M4 tap of the box next to X axis for the user grounding terminal.
 Note 6. The M4 taps at both ends of the cable carriage can be used for fixing cables.

NXY 3 axes / ZFL20 **A3**

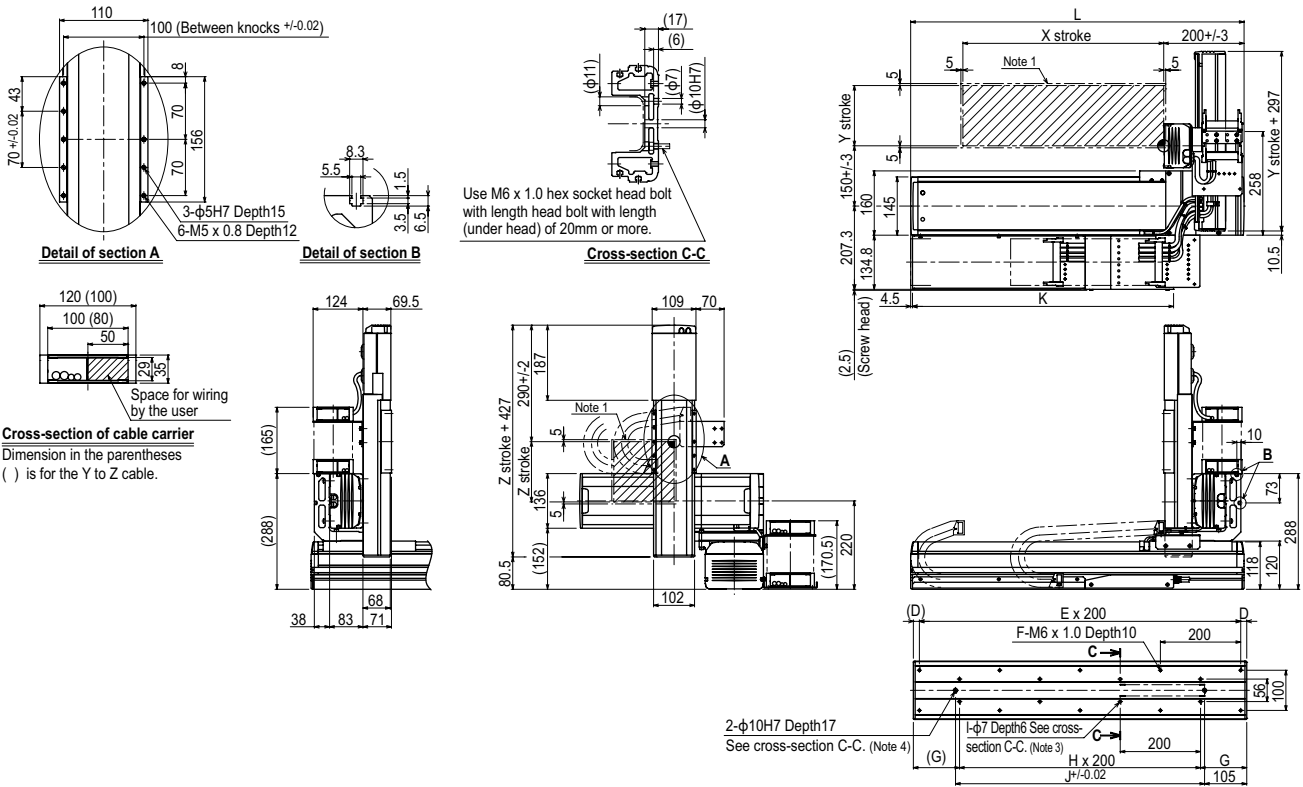

X stroke	500	600	700	800	900	1000	1100	1200	1300	1400	1500	1600	1700	1800	1900	2000
L	830	930	1030	1130	1230	1330	1430	1530	1630	1730	1830	1930	2030	2130	2230	2330
D	15	65	15	65	15	65	15	65	15	65	15	65	15	65	15	65
E	4	4	5	5	6	6	7	7	8	8	9	9	10	10	11	11
F	10	10	12	12	14	14	16	16	18	18	20	20	22	22	24	24
G	115	165	115	165	115	165	115	165	115	165	115	165	115	165	115	165
H	3	3	4	4	5	5	6	6	7	7	8	8	9	9	10	10
I	8	8	10	10	12	12	14	14	16	16	18	18	20	20	22	22
J	620	720	820	920	1020	1120	1220	1320	1420	1520	1620	1720	1820	1920	2020	2120
K	650	700	750	800	850	900	950	1000	1050	1100	1150	1200	1250	1300	1350	1400
Y stroke	150	250	350	450	550	650										
Z stroke	150	250	350													

Note 1. The moving range when returning to origin and the stop position when stopping by the mechanical stopper.
 Note 2. The origin of the X axis is set originally as the drawing and it is possible to change it to the R side origin by changing parameters.
 Note 3. When using φ7 holes for installation, you must not use a washer, spring washer, etc. in the main unit.
 Note 4. When using a φ10H7 hole, make sure that the pin does not go into deeper than as shown in the drawing.
 Note 5. Use M4 tap of the box next to X axis for the user grounding terminal.
 Note 6. The M4 taps at both ends of the cable carriage can be used for fixing cables.

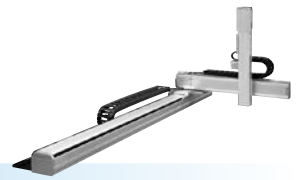

● Arm type ● Cable carrier ● Z-axis clamped table: moving base type (200W)

Ordering method

NXY - C [] [] [] **ZFH** [] [] **RCX340-3** [] [] [] [] [] [] [] [] [] [] [] []

Model	Cable	Combination	X-axis stroke	Y-axis stroke	ZR-axis	Z-axis stroke	Cable	Controller / Number of controllable axes	Safety standard	Option A (OP.A)	Option B (OP.B)	Option C (OP.C)	Option D (OP.D)	Option E (OP.E)	Absolute battery
		A1 A3	50 to 200cm	15 to 65cm		15 to 35cm	3L: 3.5m 5L: 5m 10L: 10m								

Specify various controller setting items. RCX340 ▶ **P.566**

Specification

	X-axis	Y-axis	Z-axis
Axis construction <small>Note 1</small>	N15	F14	F10H-BK
AC servo motor output (W)	400	100	200
Repeatability <small>Note 2</small> (mm)	+/-0.01	+/-0.01	+/-0.01
Drive system	Ball screw φ15	Ball screw φ15	Ball screw φ15
Ball screw lead <small>Note 3</small> (Deceleration ratio) (mm)	20	20	10
Maximum speed (mm/sec)	1200	1200	600
Moving range (mm)	500 to 2000	150 to 650	150 to 350
Robot cable length (m)	Standard: 3.5 Option: 5,10		

Note 1. Use caution that the flame machining (installation holes, tap holes) differs from single-axis robots.
 Note 2. Positioning repeatability in one direction.
 Note 3. Leads not listed in the catalog are also available. Contact us for details.

Maximum payload (kg)

Y stroke (mm)	Z stroke (mm)			
	150	250	350	650
150	13	13	12	
250	12	11	10	
350	10	9	8	
450	8	7	6	
550	5	4	3	
650	3	2	1	

Controller

Controller	Operation method
RCX340	Programming / I/O point trace / Remote command / Operation using RS-232C communication

NXY 3 axes / ZFH (A1)

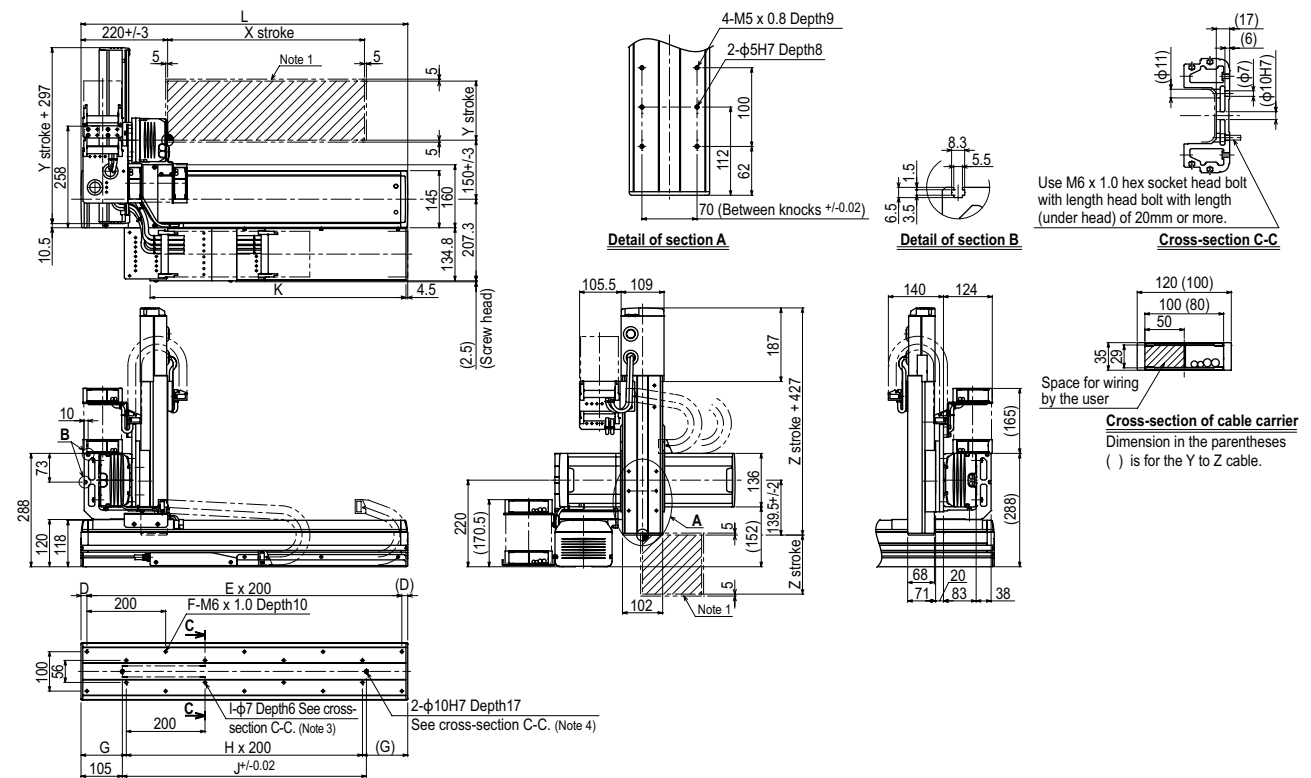

X stroke	500	600	700	800	900	1000	1100	1200	1300	1400	1500	1600	1700	1800	1900	2000
L	830	930	1030	1130	1230	1330	1430	1530	1630	1730	1830	1930	2030	2130	2230	2330
D	15	65	15	65	15	65	15	65	15	65	15	65	15	65	15	65
E	4	4	5	5	6	6	7	7	8	8	9	9	10	10	11	11
F	10	10	12	12	14	14	16	16	18	18	20	20	22	22	24	24
G	115	165	115	165	115	165	115	165	115	165	115	165	115	165	115	165
H	3	3	4	4	5	5	6	6	7	7	8	8	9	9	10	10
I	8	8	10	10	12	12	14	14	16	16	18	18	20	20	22	22
J	620	720	820	920	1020	1120	1220	1320	1420	1520	1620	1720	1820	1920	2020	2120
K	650	700	750	800	850	900	950	1000	1050	1100	1150	1200	1250	1300	1350	1400
Y stroke	150	250	350	450	550	650										
Z stroke	150	250	350													

Note 1. The moving range when returning to origin and the stop position when stopping by the mechanical stopper.
 Note 2. The origin of the X axis is set originally as the drawing and it is possible to change it to the R side origin by changing parameters.
 Note 3. When using φ7 holes for installation, you must not use a washer, spring washer, etc. in the main unit.
 Note 4. When using a φ10H7 hole, make sure that the pin does not go into deeper than as shown in the drawing.
 Note 5. Use M4 tap of the box next to X axis for the user grounding terminal.
 Note 6. The M4 taps at both ends of the cable carriage can be used for fixing cables.

NXY 3 axes / ZFH **A3**

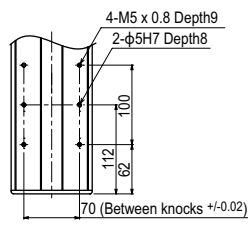

Detail of section A

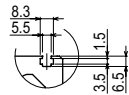

Detail of section B

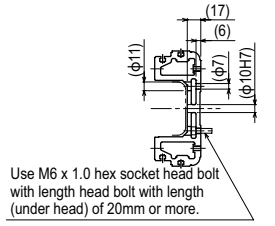

Cross-section C-C

Use M6 x 1.0 hex socket head bolt with length head bolt with length (under head) of 20mm or more.

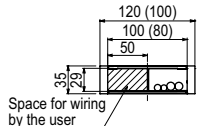

Cross-section of cable carrier
Dimension in the parentheses () is for the Y to Z cable.

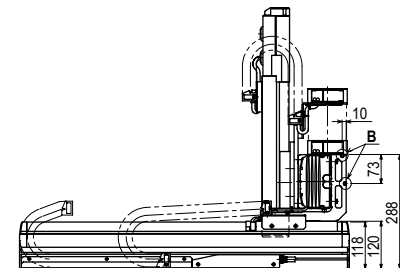
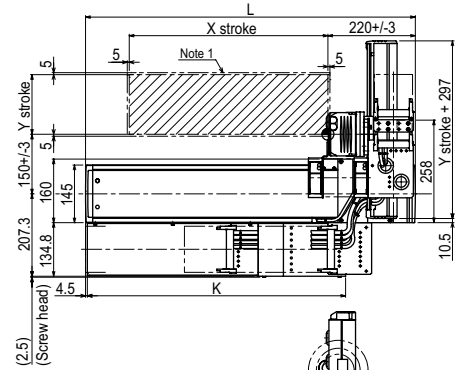
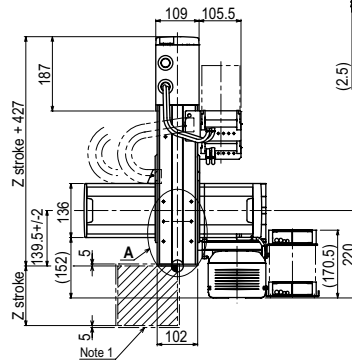
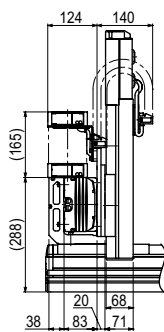

2-φ10H7 Depth17
See cross-section C-C. (Note 4)

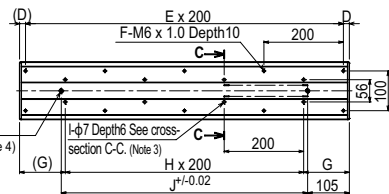

X stroke	500	600	700	800	900	1000	1100	1200	1300	1400	1500	1600	1700	1800	1900	2000
L	830	930	1030	1130	1230	1330	1430	1530	1630	1730	1830	1930	2030	2130	2230	2330
D	15	65	15	65	15	65	15	65	15	65	15	65	15	65	15	65
E	4	4	5	5	6	6	7	7	8	8	9	9	10	10	11	11
F	10	10	12	12	14	14	16	16	18	18	20	20	22	22	24	24
G	115	165	115	165	115	165	115	165	115	165	115	165	115	165	115	165
H	3	3	4	4	5	5	6	6	7	7	8	8	9	9	10	10
I	8	8	10	10	12	12	14	14	16	16	18	18	20	20	22	22
J	620	720	820	920	1020	1120	1220	1320	1420	1520	1620	1720	1820	1920	2020	2120
K	650	700	750	800	850	900	950	1000	1050	1100	1150	1200	1250	1300	1350	1400
Y stroke	150	250	350	450	550	650										
Z stroke	150	250	350													

- Note 1. The moving range when returning to origin and the stop position when stopping by the mechanical stopper.
- Note 2. The origin of the X axis is set originally as the drawing and it is possible to change it to the R side origin by changing parameters.
- Note 3. When using φ7 holes for installation, you must not use a washer, spring washer, etc. in the main unit.
- Note 4. When using a φ10H7 hole, make sure that the pin does not go into deeper than as shown in the drawing.
- Note 5. Use M4 tap of the box next to X axis for the user grounding terminal.
- Note 6. The M4 taps at both ends of the cable carriage can be used for fixing cables.

NXY-W 4 axes



● Arm type ● Cable carrier ● Double Y axes specifications

Ordering method

NXY - C - WA1				RCX340-4									
Model	Cable	Combination	X-axis stroke 25 to 175cm	Y-axis stroke 15 to 65cm ^{Note 1}	Cable 3L: 3.5m 5L: 5m 10L: 10m	Controller / Number of controllable axes	Safety standard	Option A (OP.A)	Option B (OP.B)	Option C (OP.C)	Option D (OP.D)	Option E (OP.E)	Absolute battery

Specify various controller setting items. RCX340 ▶ **P.566**

Note 1. When the Y-axis stroke is different between the right and left, it will be an order-made.

Specification

	X-axis	Y-axis ^{Note 1}
Axis construction ^{Note 2}	N15D	F14
AC servo motor output (W)	400	100
Repeatability ^{Note 3} (mm)	+/-0.01	+/-0.01
Drive system	Ball screw φ15	Ball screw φ15
Ball screw lead ^{Note 4} (Deceleration ratio) (mm)	20	20
Maximum speed (mm/sec)	1200	1200
Moving range (mm)	250 to 1750	150 to 650
Robot cable length (m)	Standard: 3.5 Option: 5, 10	

Note 1. The same two Y axes are installed and they have same specifications. If axes of individually different stroke are desired, it will be an order-made. In that case, consult YAMAHA.
 Note 2. Use caution that the frame machining (installation holes, tap holes) differs from single-axis robots.
 Note 3. Positioning repeatability in one direction.
 Note 4. Leads not listed in the catalog are also available. Contact us for details.

Maximum payload (kg)

Y stroke (mm)	XY 2 axes
150	25
250	21
350	18
450	16
550	13
650	11

Controller

Controller	Operation method
RCX340	Programming / I/O point trace / Remote command / Operation using RS-232C communication

NXY-W 4 axes WA1

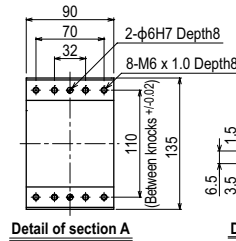
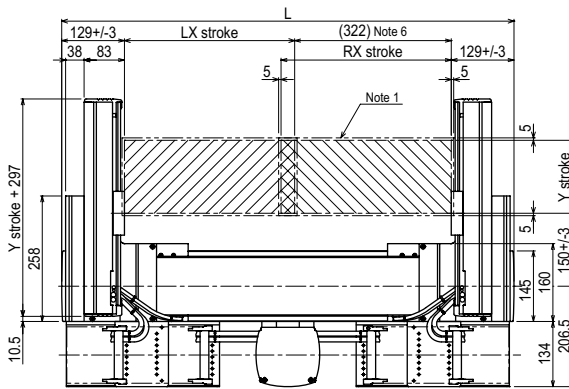

Detail of section B

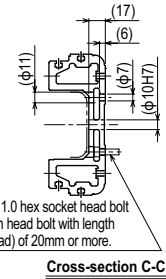

Use M6 x 1.0 hex socket head bolt with length head bolt with length (under head) of 20mm or more.

Cross-section C-C

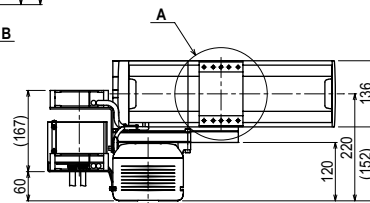
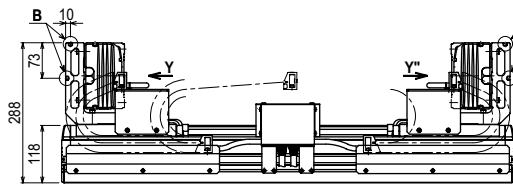

VIEW Y (Y is symmetrical with this drawing.)

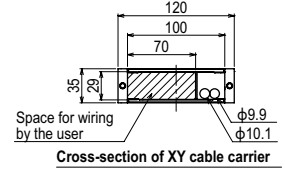

Cross-section of XY cable carrier

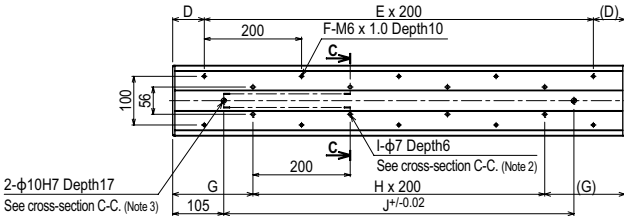

X stroke	250	350	450	550	650	750	850	950	1050	1150	1250	1350	1450	1550	1650	1750
L	830	930	1030	1130	1230	1330	1430	1530	1630	1730	1830	1930	2030	2130	2230	2330
D	15	65	15	65	15	65	15	65	15	65	15	65	15	65	15	65
E	4	4	5	5	6	6	7	7	8	8	9	9	10	10	11	11
F	10	10	12	12	14	14	16	16	18	18	20	20	22	22	24	24
G	115	165	115	165	115	165	115	165	115	165	115	165	115	165	115	165
H	3	3	4	4	5	5	6	6	7	7	8	8	9	9	10	10
I	8	8	10	10	12	12	14	14	16	16	18	18	20	20	22	22
J	620	720	820	920	1020	1120	1220	1320	1420	1520	1620	1720	1820	1920	2020	2120
Y stroke	150	250	350	450	550	650										

Note 1. The moving range when returning to origin and the stop position when stopping by the mechanical stopper.
 Note 2. When using φ7 holes for installation, you must not use a washer, spring washer, etc. in the main unit.
 Note 3. When using a φ10H7 hole, make sure that the pin does not go into deeper than as shown in the drawing.
 Note 4. Use M4 tap of the box next to X axis for the user grounding terminal.
 Note 5. The M4 taps at both ends of the cable carriage can be used for fixing cables.
 Note 6. Minimum dimension between LX and RX sliders.

NXY-W **6 axes / ZFL**

- Arm type
- Cable carrier
- Double Y axes specifications
- Z-axis: clamped base / moving table type (200W)

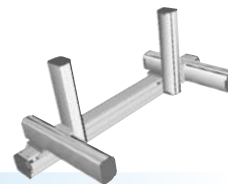

Ordering method

NXY - C - WA1 [] [] - **ZFL20** [] [] [] [] [] [] - **RCX340-4** [] [] [] [] [] [] [] [] [] [] []

Model	Cable	Combination	X-axis stroke 25 to 175cm	Y-axis stroke 15 to 65cm ^{Note 1}	ZR-axis	Z-axis stroke 15 to 35cm	Cable 3L: 3.5m 6L: 5m 10L: 10m	Controller / Number of controllable axes	Safety standard	Option A (OP.A)	Option B (OP.B)	Option C (OP.C)	Option D (OP.D)	Option E (OP.E)	Absolute battery
-------	-------	-------------	------------------------------	---	---------	-----------------------------	---	--	-----------------	-----------------	-----------------	-----------------	-----------------	-----------------	------------------

Specify various controller setting items. RCX340 ▶ **P.566**

Note 1. When either one or both of Y-axis or Z-axis stroke is different, it will be an order-made.

Specification

	X-axis	Y-axis ^{Note 1}	Z-axis
Axis construction ^{Note 2}	N15D	F14	F10H-BK
AC servo motor output (W)	400	100	200
Repeatability ^{Note 3} (mm)	+/-0.01	+/-0.01	+/-0.01
Drive system	Ball screw φ15	Ball screw φ15	Ball screw φ15
Ball screw lead ^{Note 4} (Deceleration ratio) (mm)	20	20	20
Maximum speed (mm/sec)	1200	1200	1200
Moving range (mm)	250 to 1750	150 to 650	150 to 350
Robot cable length (m)	Standard: 3.5 Option: 5,10		

Note 1. The same two Y axes are installed and they have same specifications. If axes of individually different stroke are desired, it will be an order-made. In that case, consult YAMAHA.

Note 2. Use caution that the flame machining (installation holes, tap holes) differs from single-axis robots.

Note 3. Positioning repeatability in one direction.

Note 4. Leads not listed in the catalog are also available. Contact us for details.

Maximum payload (kg)

Y stroke (mm)	Z stroke (mm)		
	150	250	350
150	8	8	8
250	8	8	8
350	8	8	8
450	8	7	6
550	5	4	3
650	3	2	1

Controller

Controller	Operation method
RCX340	Programming / I/O point trace / Remote command / Operation using RS-232C communication

NXY-W 6 axes / ZFL **WA1**

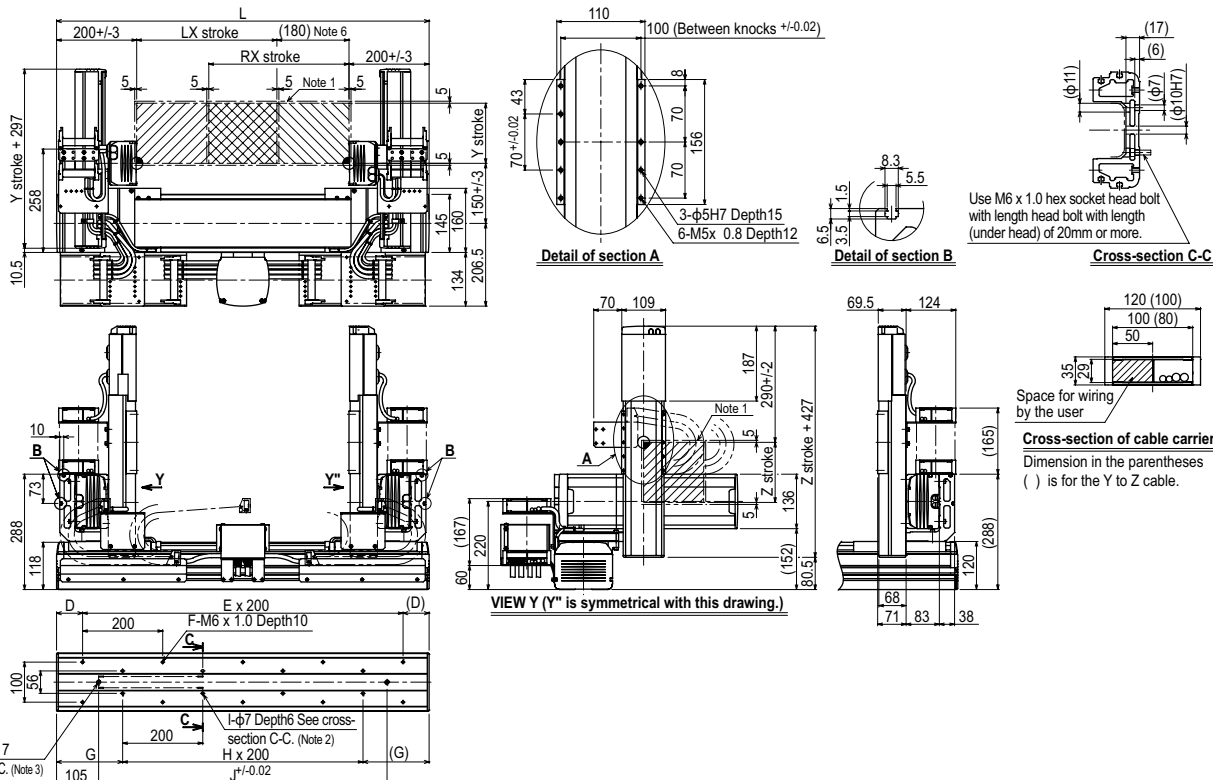

X stroke	250	350	450	550	650	750	850	950	1050	1150	1250	1350	1450	1550	1650	1750
L	830	930	1030	1130	1230	1330	1430	1530	1630	1730	1830	1930	2030	2130	2230	2330
D	15	65	15	65	15	65	15	65	15	65	15	65	15	65	15	65
E	4	4	5	5	6	6	7	7	8	8	9	9	10	10	11	11
F	10	10	12	12	14	14	16	16	18	18	20	20	22	22	24	24
G	115	165	115	165	115	165	115	165	115	165	115	165	115	165	115	165
H	3	3	4	4	5	5	6	6	7	7	8	8	9	9	10	10
I	8	8	10	10	12	12	14	14	16	16	18	18	20	20	22	22
J	620	720	820	920	1020	1120	1220	1320	1420	1520	1620	1720	1820	1920	2020	2120
Y stroke	150	250	350	450	550	650										
Z stroke	150	250	350													

- Note 1. The moving range when returning to origin and the stop position when stopping by the mechanical stopper.
- Note 2. When using φ7 holes for installation, you must not use a washer, spring washer, etc. in the main unit.
- Note 3. When using a φ10H7 hole, make sure that the pin does not go into deeper than as shown in the drawing.
- Note 4. Use M4 tap of the box next to X axis for the user grounding terminal.
- Note 5. The M4 taps at both ends of the cable carriage can be used for fixing cables.
- Note 6. Minimum dimension between LX and RX sliders.

NXY-W 6 axes / ZFH

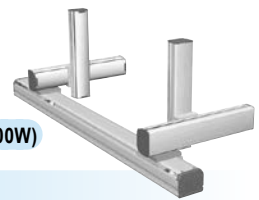

● Arm type ● Cable carrier ● Double Y axes specifications ● Z-axis: clamped table / moving base type (200W)

Ordering method

NXY - C - WA1 [] [] **ZFH** [] [] **RCX340-4** [] [] [] [] [] [] [] [] []

Model	Cable	Combination	X-axis stroke 25 to 175cm	Y-axis stroke 15 to 65cm ^{Note 1}	ZR-axis	Z-axis stroke 15 to 35cm	Cable	Controller / Number of controllable axes	Safety standard	Option A (OP.A)	Option B (OP.B)	Option C (OP.C)	Option D (OP.D)	Option E (OP.E)	Absolute battery	
							3L: 3.5m 5L: 5m 10L: 10m									

Specify various controller setting items. RCX340 ▶ P.566

Note 1. When either one or both of Y-axis or Z-axis stroke is different, it will be an order-made.

Specification

	X-axis	Y-axis ^{Note 1}	Z-axis
Axis construction ^{Note 2}	N15D	F14	F10H-BK
AC servo motor output (W)	400	100	200
Repeatability ^{Note 3} (mm)	+/-0.01	+/-0.01	+/-0.01
Drive system	Ball screw φ15	Ball screw φ15	Ball screw φ15
Ball screw lead ^{Note 4} (Deceleration ratio) (mm)	20	20	10
Maximum speed (mm/sec)	1200	1200	600
Moving range (mm)	250 to 1750	150 to 650	150 to 350
Robot cable length (m)	Standard: 3.5 Option: 5, 10		

Note 1. The same two Y axes are installed and they have same specifications. If axes of individually different stroke are desired, it will be an order-made. In that case, consult YAMAHA.

Note 2. Use caution that the frame machining (installation holes, tap holes) differs from single-axis robots.

Note 3. Positioning repeatability in one direction.

Note 4. Leads not listed in the catalog are also available. Contact us for details.

Maximum payload (kg)

Y stroke (mm)	Z stroke (mm)		
	150	250	350
150	13	13	12
250	12	11	10
350	10	9	8
450	8	7	6
550	5	4	3
650	3	2	1

Controller

Controller	Operation method
RCX340	Programming / I/O point trace / Remote command / Operation using RS-232C communication

NXY-W 6 axes / ZFH WA1

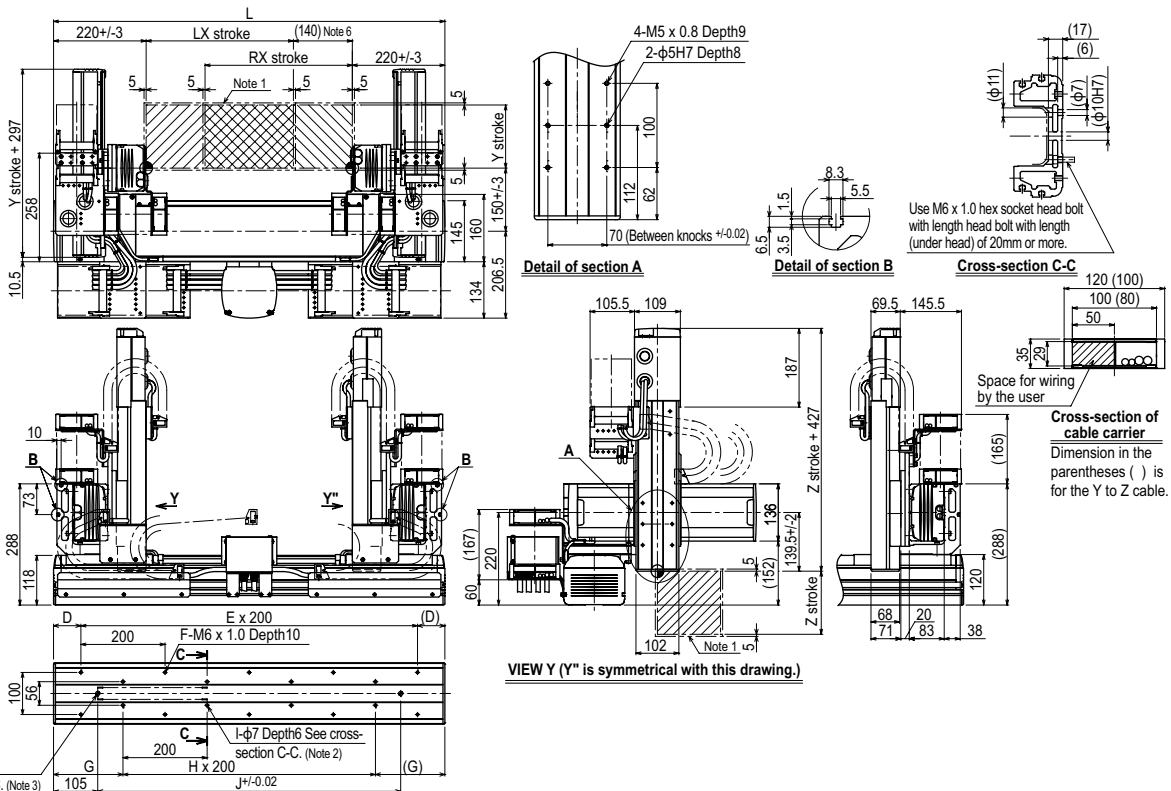

X stroke	250	350	450	550	650	750	850	950	1050	1150	1250	1350	1450	1550	1650	1750
L	830	930	1030	1130	1230	1330	1430	1530	1630	1730	1830	1930	2030	2130	2230	2330
D	15	65	15	65	15	65	15	65	15	65	15	65	15	65	15	65
E	4	4	5	5	6	6	7	7	8	8	9	9	10	10	11	11
F	10	10	12	12	14	14	16	16	18	18	20	20	22	22	24	24
G	115	165	115	165	115	165	115	165	115	165	115	165	115	165	115	165
H	3	3	4	4	5	5	6	6	7	7	8	8	9	9	10	10
I	8	8	10	10	12	12	14	14	16	16	18	18	20	20	22	22
J	620	720	820	920	1020	1120	1220	1320	1420	1520	1620	1720	1820	1920	2020	2120
Y stroke	150	250	350	450	550	650										
Z stroke	150	250	350													

Note 1. The moving range when returning to origin and the stop position when stopping by the mechanical stopper.
 Note 2. When using φ7 holes for installation, you must not use a washer, spring washer, etc. in the main unit.
 Note 3. When using a φ10H7 hole, make sure that the pin does not go into deeper than as shown in the drawing.
 Note 4. Use M4 tap of the box next to X axis for the user grounding terminal.
 Note 5. The M4 taps at both ends of the cable carriage can be used for fixing cables.
 Note 6. Minimum dimension between LX and RX sliders.

Articulated robots YA	Linear conveyor modules LCM100	Motor-less single axis actuator Robonity	Compact single-axis robots TRANSERVO	Single-axis robots FLIP-X	Linear motor single-axis robots PHASER	Cartesian robots XY-X	SCARA robots YK-X	Pick & place robots YP-X	CLEAN	CONTROLLER	INFORMATION	Arm type	Gantry type	Moving arm type	Pole type	XZ type
---------------------------------	---	---	---	-------------------------------------	---	------------------------------------	--------------------------------	---------------------------------------	--------------	-------------------	--------------------	----------	-------------	--------------------	-----------	----------------

MXYx 2 axes



- Arm type
- Cable carrier

Ordering method

MXYx - C

Model	Cable	Combination	X-axis stroke	Y-axis stroke	Cable
A1			25 to 125cm	15 to 65cm	3L: 3.5m 5L: 5m 10L: 10m
A2					
A3					
A4					

RCX320-2 **R**

Controller / Number of controllable axes	Safety standard	Regenerative unit	Option A (OP.A)	Option B (OP.B)	Vision System	Absolute battery
--	-----------------	-------------------	-----------------	-----------------	---------------	------------------

Specify various controller setting items. **RCX320 ▶ P.548**

RCX222 **R**

Controller	Usable for CE	Regenerative unit	I/O selection 1	I/O selection 2
------------	---------------	-------------------	-----------------	-----------------

Specify various controller setting items. **RCX222 ▶ P.558**

Specification

	X-axis	Y-axis
Axis construction ^{Note 1}	F17	F14H
AC servo motor output (W)	400	200
Repeatability ^{Note 2} (mm)	+/-0.01	+/-0.01
Drive system	Ball screw φ20	Ball screw φ15
Ball screw lead ^{Note 3} (Deceleration ratio) (mm)	20	20
Maximum speed ^{Note 4} (mm/sec)	1200	1200
Moving range (mm)	250 to 1250	150 to 650
Robot cable length (m)	Standard: 3.5 Option: 5,10	

- Note 1. Use caution that the flame machining (installation holes, tap holes) differs from single-axis robots.
 Note 2. Positioning repeatability in one direction.
 Note 3. Leads not listed in the catalog are also available. Contact us for details.
 Note 4. When the X-axis stroke is longer than 850mm, resonance of the ball screw may occur depending on the operation conditions (critical speed). In this case, reduce the speed setting on the program by referring to the maximum speeds shown in the table below.

Maximum payload (kg)

Y stroke (mm)	XY 2 axes
150	30
250	30
350	25
450	20
550	20
650	16

Controller

Controller	Operation method
RCX320-R	Programming / I/O point trace / Remote command / Operation using RS-232C communication
RCX222-R	

MXYx 2 axes A1

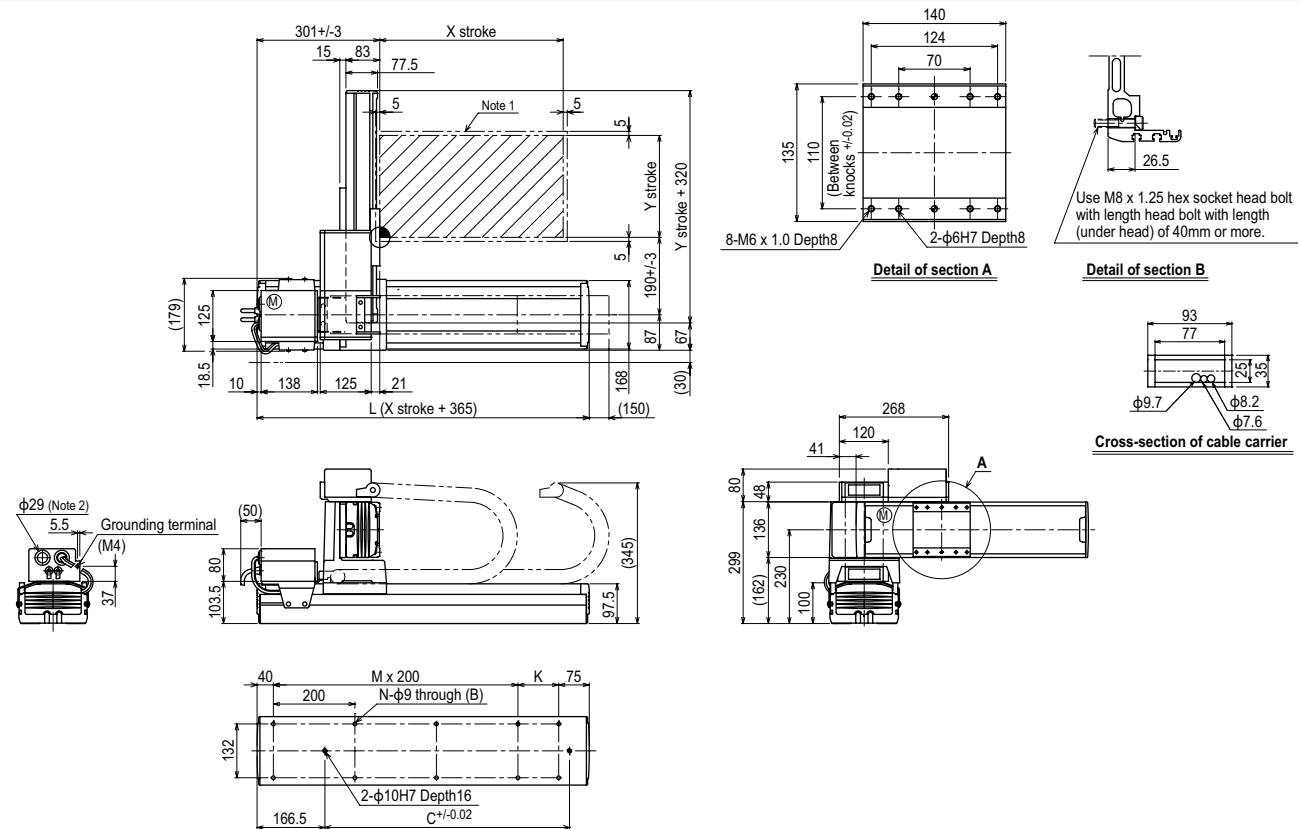

X stroke	250	350	450	550	650	750	850	950	1050	1150	1250
L	615	715	815	915	1015	1115	1215	1315	1415	1515	1615
K	100	200	100	200	100	200	100	200	100	200	100
C	240	420	600	600	780	780	960	960	1140	1140	1320
M	2	2	3	3	4	4	5	5	6	6	7
N	8	8	10	10	12	12	14	14	16	16	18
Y stroke	150	250	350	450	550	650					
Maximum speed for each stroke (mm/sec) ^{Note 3}	X-axis		1200				960	840	720	600	480
Speed setting			-				80%	70%	60%	50%	40%

- Note 1. The moving range when returning to origin and the stop position when stopping by the mechanical stopper.
 Note 2. User cable extraction port.

- Note 3. When the X-axis stroke is longer than 850mm, resonance of the ball screw may occur depending on the operation conditions (critical speed). In this case, reduce the speed setting on the program by referring to the maximum speeds shown in the table at the left.

Articulated robots
YA
 Linear conveyor modules
LCM100
 Motor-less single axis actuator
Robonity
 Compact single-axis robots
TRANSEVO
 Single-axis robots
FLIP-X
 Linear motor single-axis robots
PHASER
 Cartesian robots
XY-X
 SCARA robots
YK-X
 Pick & place robots
YP-X
 CLEAN
 CONTROLLER INFORMATION
 Arm type
 Gantry type
 Moving arm type
 Pole type
 XZ type

MXyX 2 axes A2

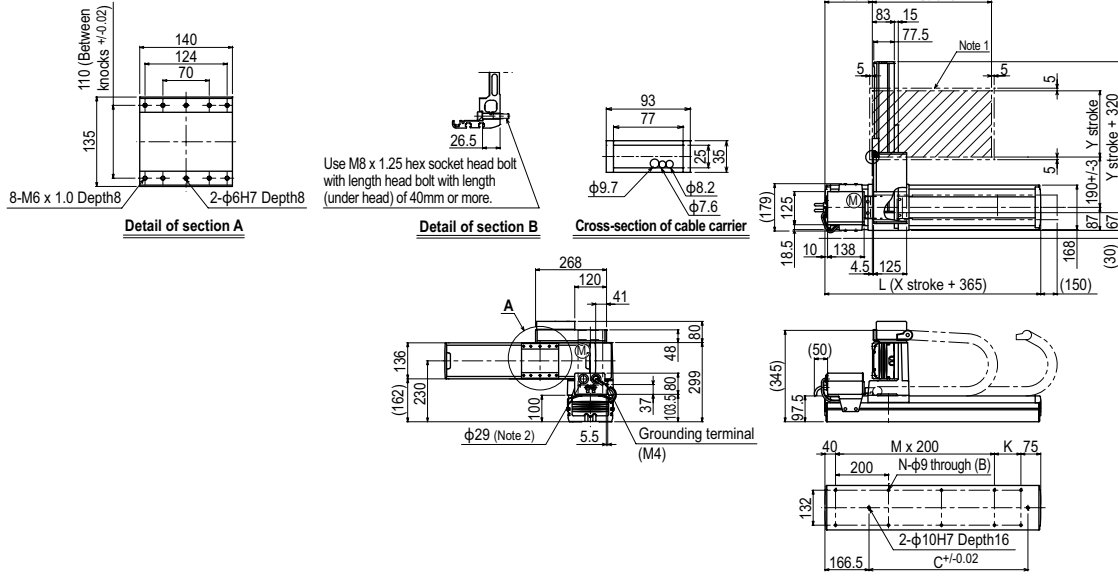

MXyX 2 axes A3

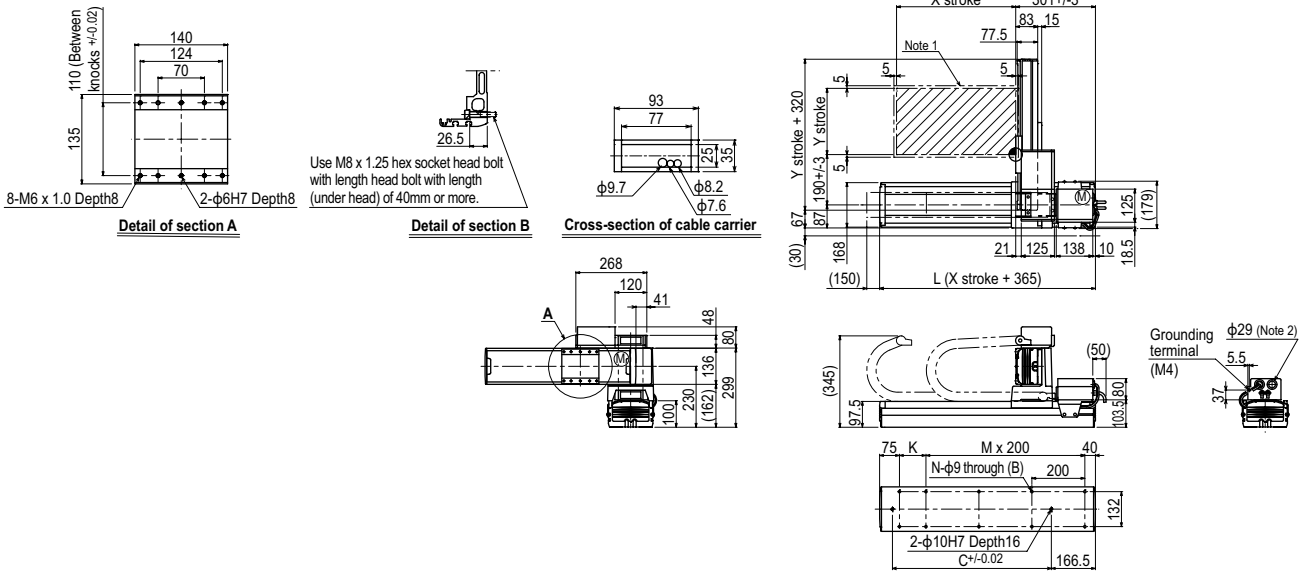

MXyX 2 axes A4

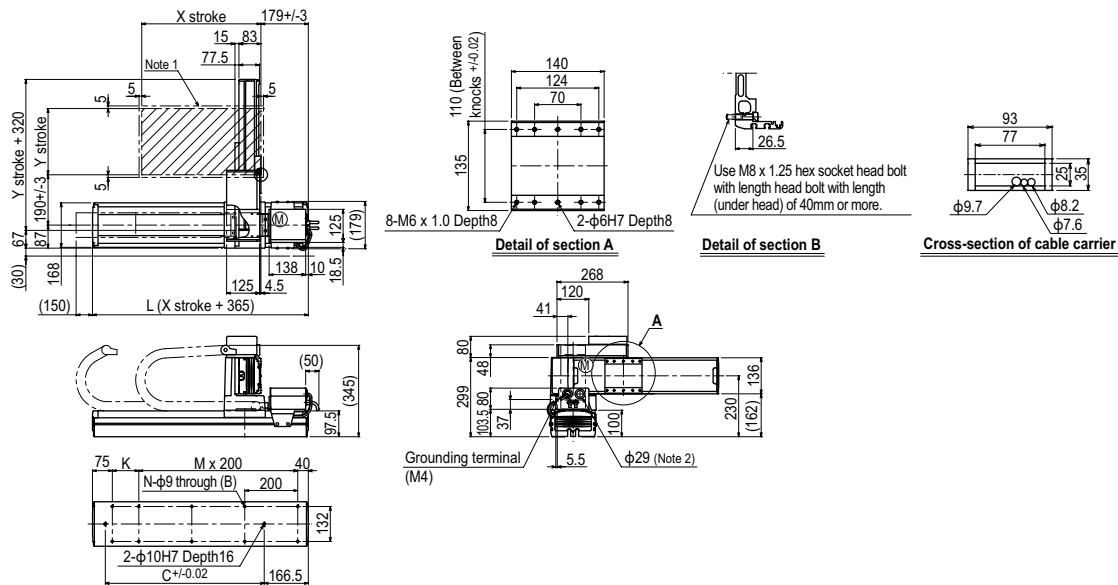

MXYx 2 axes

● Arm type ● Whipover

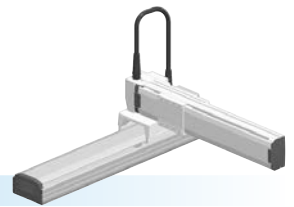

Ordering method

MXYx - S

Model	Cable	Combination	X-axis stroke	Y-axis stroke	Cable
A1			25 to 85cm	15 to 65cm	3L: 3.5m
A2					5L: 5m
A3					10L: 10m
A4					

RCX320-2 **R**

Controller / Number of controllable axes	Safety standard	Regenerative unit	Option A (OP.A)	Option B (OP.B)	Vision System	Absolute battery

Specify various controller setting items. RCX320 ▶ **P.548**

RCX222 **R**

Controller	Usable for CE	Regenerative unit	I/O selection 1	I/O selection 2

Specify various controller setting items. RCX222 ▶ **P.558**

Specification

	X-axis	Y-axis
Axis construction <small>Note 1</small>	F17	F14H
AC servo motor output (W)	400	200
Repeatability <small>Note 2</small> (mm)	+/-0.01	+/-0.01
Drive system	Ball screw φ20	Ball screw φ15
Ball screw lead <small>Note 3</small> (Deceleration ratio) (mm)	20	20
Maximum speed <small>Note 4</small> (mm/sec)	1200	1200
Moving range (mm)	250 to 850	150 to 650
Robot cable length (m)	Standard: 3.5 Option: 5,10	

Note 1. Use caution that the flame machining (installation holes, tap holes) differs from single-axis robots.
 Note 2. Positioning repeatability in one direction.
 Note 3. Leads not listed in the catalog are also available. Contact us for details.
 Note 4. When the X-axis stroke is longer than 850mm, resonance of the ball screw may occur depending on the operation conditions (critical speed). In this case, reduce the speed setting on the program by referring to the maximum speeds shown in the table below.

Maximum payload (kg)

Y stroke (mm)	XY 2 axes
150	30
250	30
350	25
450	20
550	20
650	16

Controller

Controller	Operation method
RCX320-R	Programming / I/O point trace / Remote command / Operation using RS-232C communication
RCX222-R	

MXYx 2 axes A1

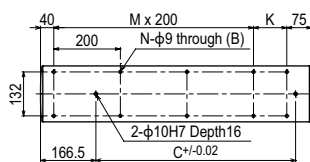
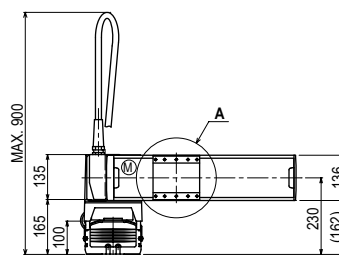
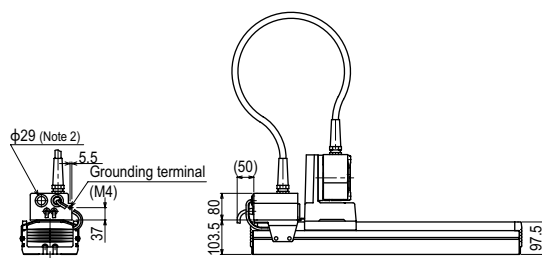
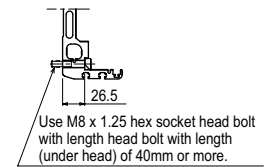
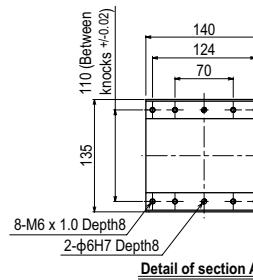
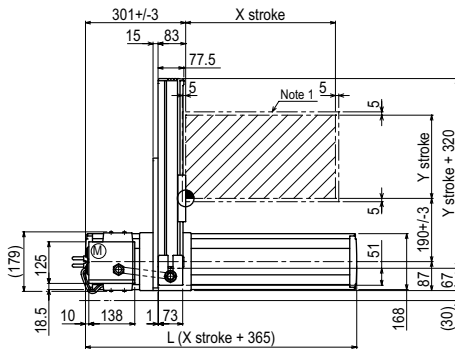

X stroke	250	350	450	550	650	750	850	
L	615	715	815	915	1015	1115	1215	
K	100	200	100	200	100	200	100	
C	240	420	600	600	780	780	960	
M	2	2	3	3	4	4	5	
N	8	8	10	10	12	12	14	
Y stroke	150	250	350	450	550	650		
Maximum speed for each stroke (mm/sec) <small>Note 3</small>	X-axis		1200				960	
Speed setting			-				80%	

Note 1. The moving range when returning to origin and the stop position when stopping by the mechanical stopper.
 Note 2. User cable extraction port.

Note 3. When the X-axis stroke is longer than 850mm, resonance of the ball screw may occur depending on the operation conditions (critical speed). In this case, reduce the speed setting on the program by referring to the maximum speeds shown in the table at the left.

Articulated robots
YA
Linear conveyor modules
LCM100
Motor-less single axis actuator
Robonity
Compact single-axis robots
TRANSEVO
Single-axis robots
FLIP-X
Linear motor single-axis robots
PHASER
Cartesian robots
XY-X
SCARA robots
YK-X
Pick & place robots
YP-X
CLEAN
CONTROLLER INFORMATION
Arm type
Gantry type
Moving arm type
Pole type
XZ type

MXyX 2 axes **A2**

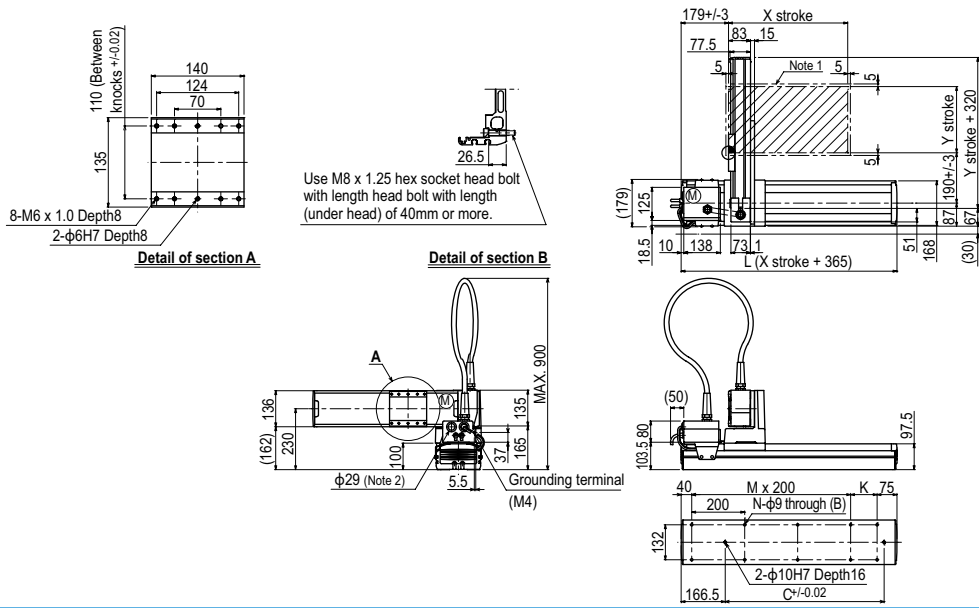

MXyX 2 axes **A3**

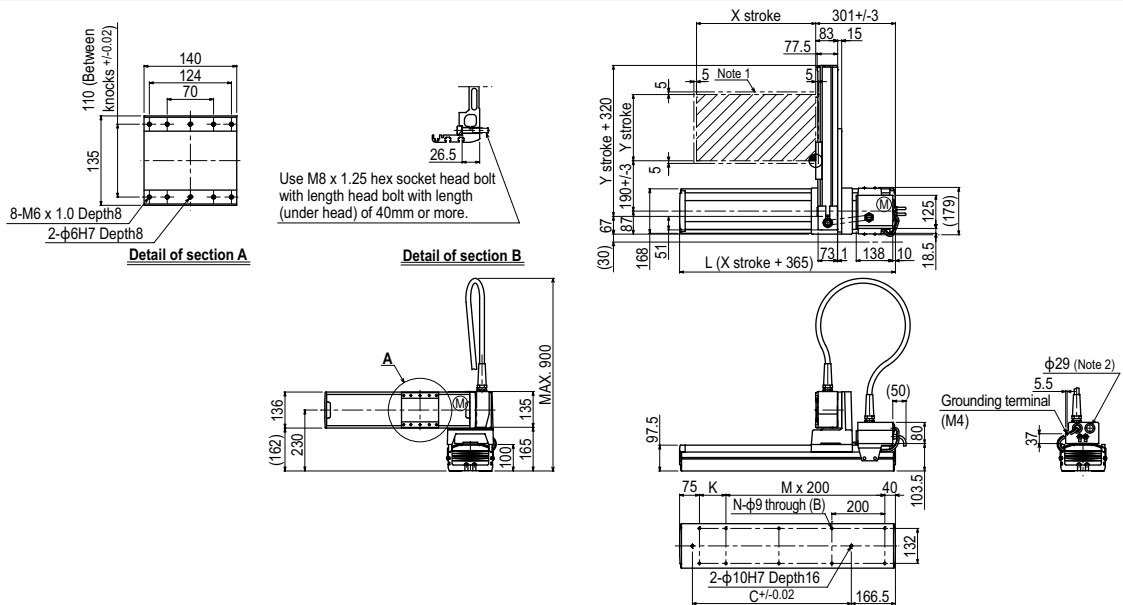

MXyX 2 axes **A4**

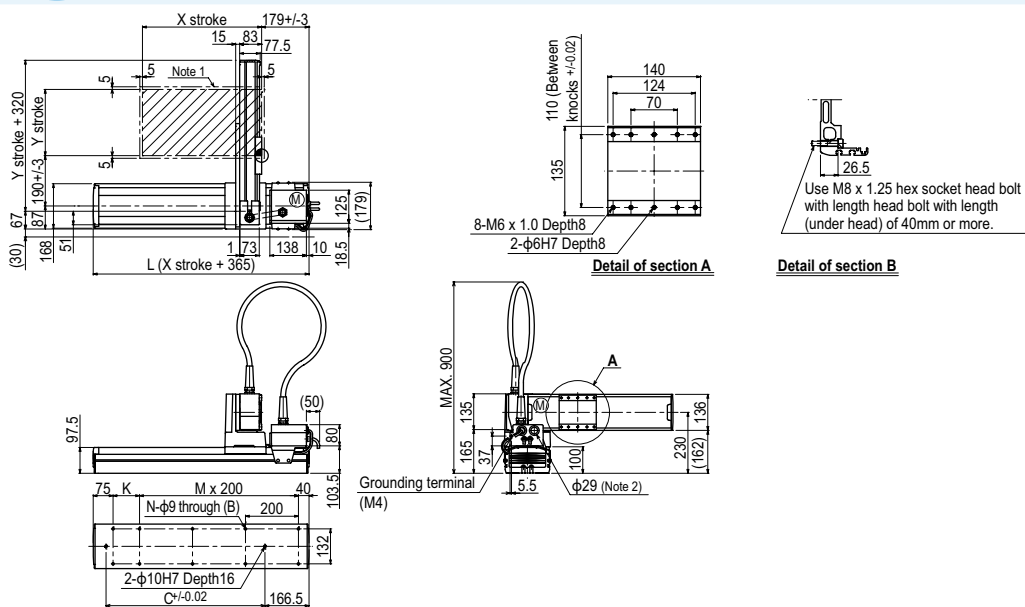

MXYx

2 axes / IO

- Arm type
- Cable carrier
- Type with Y-axis I/O cable carrier added

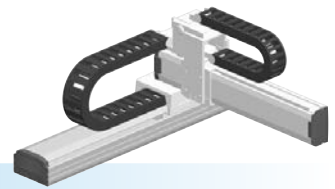

Ordering method

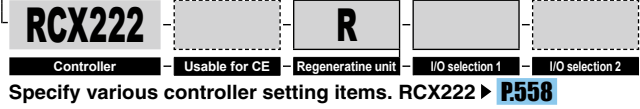
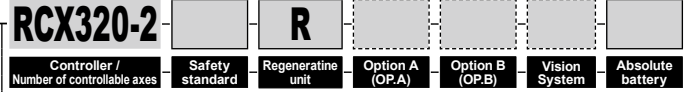
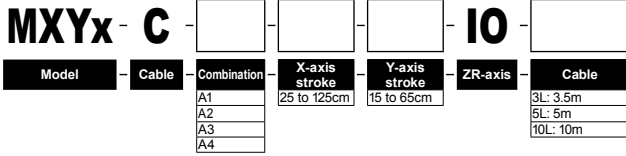

Specification

	X-axis	Y-axis
Axis construction ^{Note 1}	F17	F14H
AC servo motor output (W)	400	200
Repeatability ^{Note 2} (mm)	+/-0.01	+/-0.01
Drive system	Ball screw φ20	Ball screw φ15
Ball screw lead ^{Note 3} (Deceleration ratio) (mm)	20	20
Maximum speed ^{Note 4} (mm/sec)	1200	1200
Moving range (mm)	250 to 1250	150 to 650
Robot cable length (m)	Standard: 3.5 Option: 5, 10	

Note 1. Use caution that the flame machining (installation holes, tap holes) differs from single-axis robots.
 Note 2. Positioning repeatability in one direction.
 Note 3. Leads not listed in the catalog are also available. Contact us for details.
 Note 4. When the X-axis stroke is longer than 850mm, resonance of the ball screw may occur depending on the operation conditions (critical speed). In this case, reduce the speed setting on the program by referring to the maximum speeds shown in the table below.

Maximum payload (kg)

Y stroke (mm)	XY 2 axes
150	29
250	29
350	24
450	19
550	19
650	15

Controller

Controller	Operation method
RCX320-R	Programming / I/O point trace / Remote command / Operation using RS-232C communication
RCX222-R	

MXYx 2 axes / IO (A1)

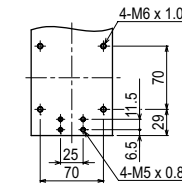
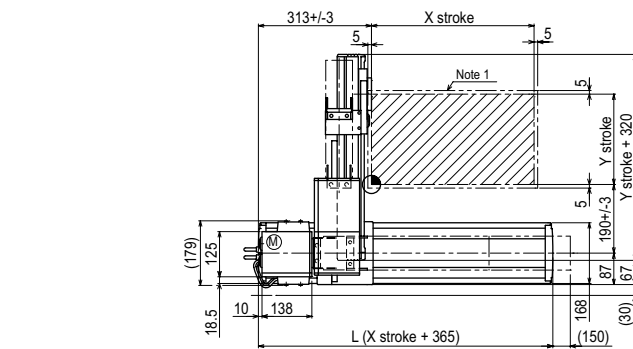

Detail of section A

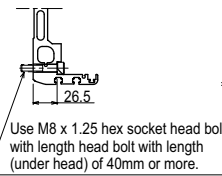

Detail of section B

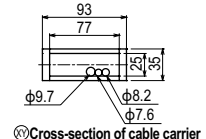

① Cross-section of cable carrier

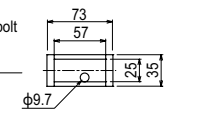

② Cross-section of cable carrier

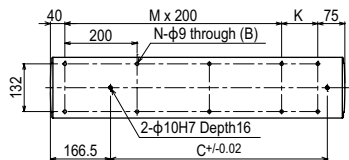
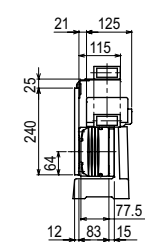
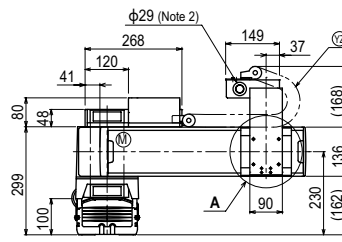
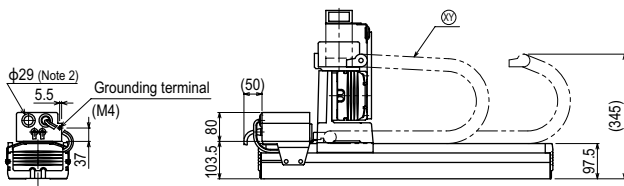

X stroke	250	350	450	550	650	750	850	950	1050	1150	1250
L	615	715	815	915	1015	1115	1215	1315	1415	1515	1615
K	100	200	100	200	100	200	100	200	100	200	100
C	240	420	600	780	780	960	960	1140	1140	1320	1320
M	2	2	3	3	4	4	5	5	6	6	7
N	8	8	10	10	12	12	14	14	16	16	18
Y stroke	150	250	350	450	550	650					
Maximum speed for each stroke (mm/sec) ^{Note 3}	X-axis		1200				960	840	720	600	480
Speed setting			-				80%	70%	60%	50%	40%

Note 1. The moving range when returning to origin and the stop position when stopping by the mechanical stopper.
 Note 2. User cable extraction port.

Note 3. When the X-axis stroke is longer than 850mm, resonance of the ball screw may occur depending on the operation conditions (critical speed). In this case, reduce the speed setting on the program by referring to the maximum speeds shown in the table at the left.

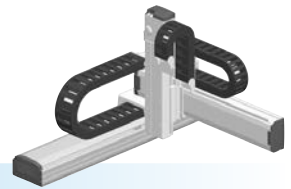

- Arm type
- Cable carrier
- Z-axis: clamped table / moving base type (200W)

Ordering method

MXYx - C - **ZFH** - **RCX340-3**

Model	Cable	Combination	X-axis stroke	Y-axis stroke	ZR-axis	Z-axis stroke	Cable	Controller / Number of controllable axes	Safety standard	Option A (OP.A)	Option B (OP.B)	Option C (OP.C)	Option D (OP.D)	Option E (OP.E)	Absolute battery
		A1 A2 A3 A4	25 to 125cm	15 to 65cm		15 to 35cm	3L: 3.5m 5L: 5m 10L: 10m								

Specify various controller setting items. RCX340 ▶ **P.566**

Specification

	X-axis	Y-axis	Z-axis
Axis construction ^{Note 1}	F17	F14H	F10H-BK
AC servo motor output (W)	400	200	200
Repeatability ^{Note 2} (mm)	+/-0.01	+/-0.01	+/-0.01
Drive system	Ball screw φ20	Ball screw φ15	Ball screw φ15
Ball screw lead ^{Note 3} (Deceleration ratio) (mm)	20	20	10
Maximum speed ^{Note 4} (mm/sec)	1200	1200	600
Moving range (mm)	250 to 1250	150 to 650	150 to 350
Robot cable length (m)	Standard: 3.5 Option: 5,10		

Note. The standard types are ZFH with higher rigidity as compared with ZF types which are conventional standard types. When you need the ZF type, please consult YAMAHA.

Note 1. Use caution that the frame machining (installation holes, tap holes) differs from single-axis robots.

Note 2. Positioning repeatability in one direction.

Note 3. Leads not listed in the catalog are also available. Contact us for details.

Note 4. When the X-axis stroke is longer than 850mm, resonance of the ball screw may occur depending on the operation conditions (critical speed). In this case, reduce the speed setting on the program by referring to the maximum speeds shown in the table below.

Maximum payload (kg)

Y stroke (mm)	Z stroke (mm)		
	150	250	350
150	14	13	12
250	14	13	12
350	14	13	12
450	12	11	10
550	12	11	10
650	8	7	6

Controller

Controller	Operation method
RCX340	Programming / I/O point trace / Remote command / Operation using RS-232C communication

MXYx 3 axes / ZFH A1

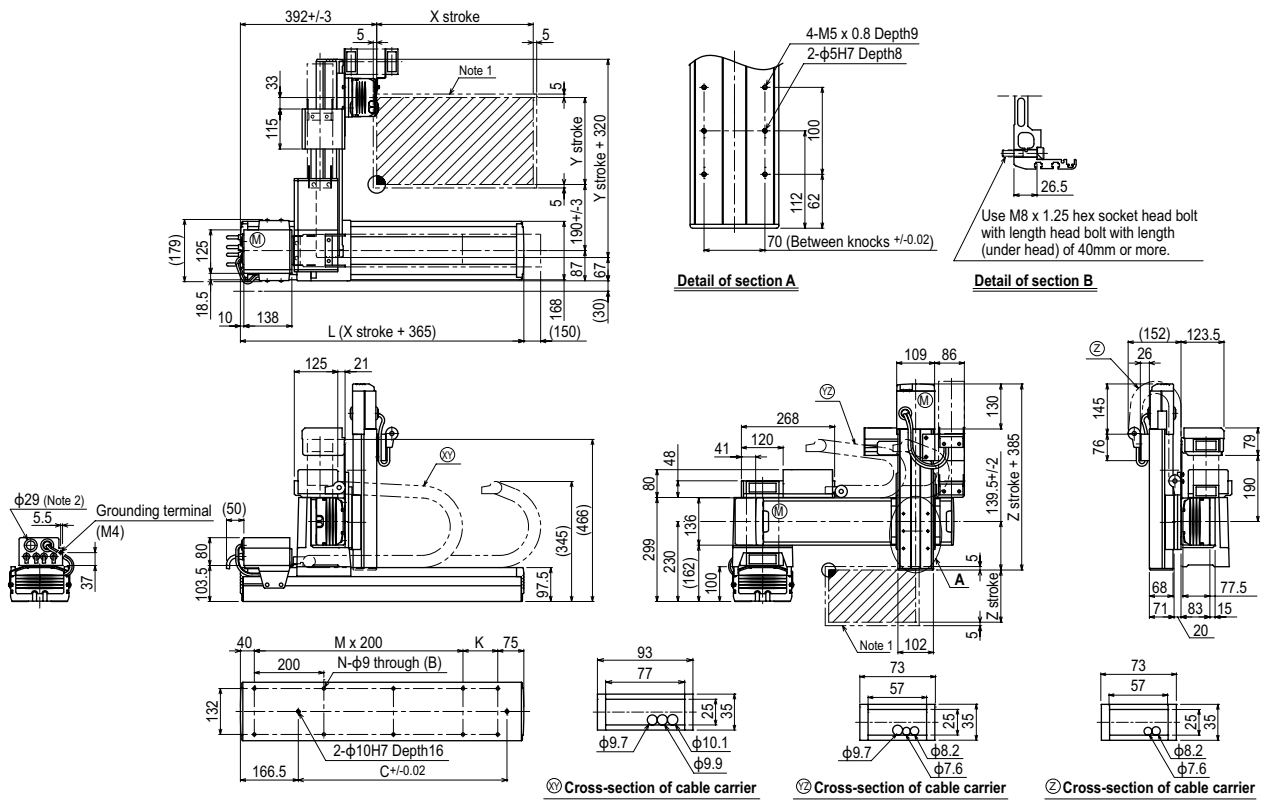

X stroke	250	350	450	550	650	750	850	950	1050	1150	1250	
L	615	715	815	915	1015	1115	1215	1315	1415	1515	1615	
K	100	200	100	200	100	200	100	200	100	200	100	
C	240	420	600	600	780	780	960	960	1140	1140	1320	
M	2	2	3	3	4	4	5	5	6	6	7	
N	8	8	10	10	12	12	14	14	16	16	18	
Y stroke	150	250	350	450	550	650						
Z stroke	150	250	350									
Maximum speed for each stroke (mm/sec) ^{Note 1}	X-axis		1200				960		840	720	600	480
Speed setting			-				80%		70%	60%	50%	40%

Note 1. The moving range when returning to origin and the stop position when stopping by the mechanical stopper.

Note 2. User cable extraction port.

Note 3. When the X-axis stroke is longer than 850mm, resonance of the ball screw may occur depending on the operation conditions (critical speed). In this case, reduce the speed setting on the program by referring to the maximum speeds shown in the table at the left.

● Arm type ● Cable carrier ● Z-axis: clamped base / moving table type (200W)+R-axis

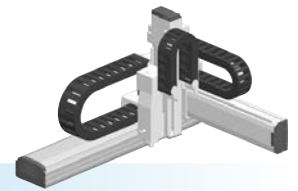

Ordering method

MXy_x - C							RCX340-4									
Model	Cable	Combination	X-axis stroke	Y-axis stroke	ZR-axis	Z-axis stroke	Controller / Number of controllable axes	Safety standard	Option A (OP.A)	Option B (OP.B)	Option C (OP.C)	Option D (OP.D)	Option E (OP.E)	Absolute battery		
A1		A1	25 to 125cm	15 to 65cm	ZRFL20	15 to 35cm										
A2		A2			ZRFL10											
A3		A3														
A4		A4														

Specify various controller setting items. RCX340 ▶ P.566

Specification

	X-axis	Y-axis	Z-axis: ZRFL20	Z-axis: ZRFL10	R-axis
Axis construction ^{Note 1}	F17	F14H	F10H-BK		R5
AC servo motor output (W)	400	200	200		50
Repeatability ^{Note 2} (XYZ: mm) (R: °)	+/-0.01	+/-0.01	+/-0.01		+/-0.0083
Drive system	Ball screw φ20	Ball screw φ15	Ball screw φ15		Harmonic gear
Ball screw lead ^{Note 3} (Deceleration ratio) (mm)	20	20	20	10	(1/50)
Maximum speed ^{Note 4} (XYZ: mm/sec) (R: %/sec)	1200	1200	1200	600	360
Moving range (XYZ: mm)(R: °)	250 to 1250	150 to 650	150 to 350		360
Robot cable length (m)	Standard: 3.5 Option: 5.10				

Note. The standard types are ZRFL with higher rigidity as compared with ZRF types which are conventional standard types. When you need the ZRF type, please consult YAMAHA.
 Note 1. Use caution that the flame machining (installation holes, tap holes) differs from single-axis robots.
 Note 2. Positioning repeatability in one direction.
 Note 3. Leads not listed in the catalog are also available. Contact us for details.
 Note 4. When the X-axis stroke is longer than 850mm, resonance of the ball screw may occur depending on the operation conditions (critical speed). In this case, reduce the speed setting on the program by referring to the maximum speeds shown in the table below.

Maximum payload (kg)

Y stroke (mm)	Z stroke (mm)					
	ZRFL20			ZRFL10		
	150	250	350	150	250	350
150	4	4	4	11	11	11
250	4	4	4	11	11	11
350	4	4	4	11	11	11
450	4	4	4	8	7	6
550	4	4	4	8	7	6
650	4	4	4	4	3	2

Controller

Controller	Operation method
RCX340	Programming / I/O point trace / Remote command / Operation using RS-232C communication

MXy4 axes / ZRFL20/10 (A1)

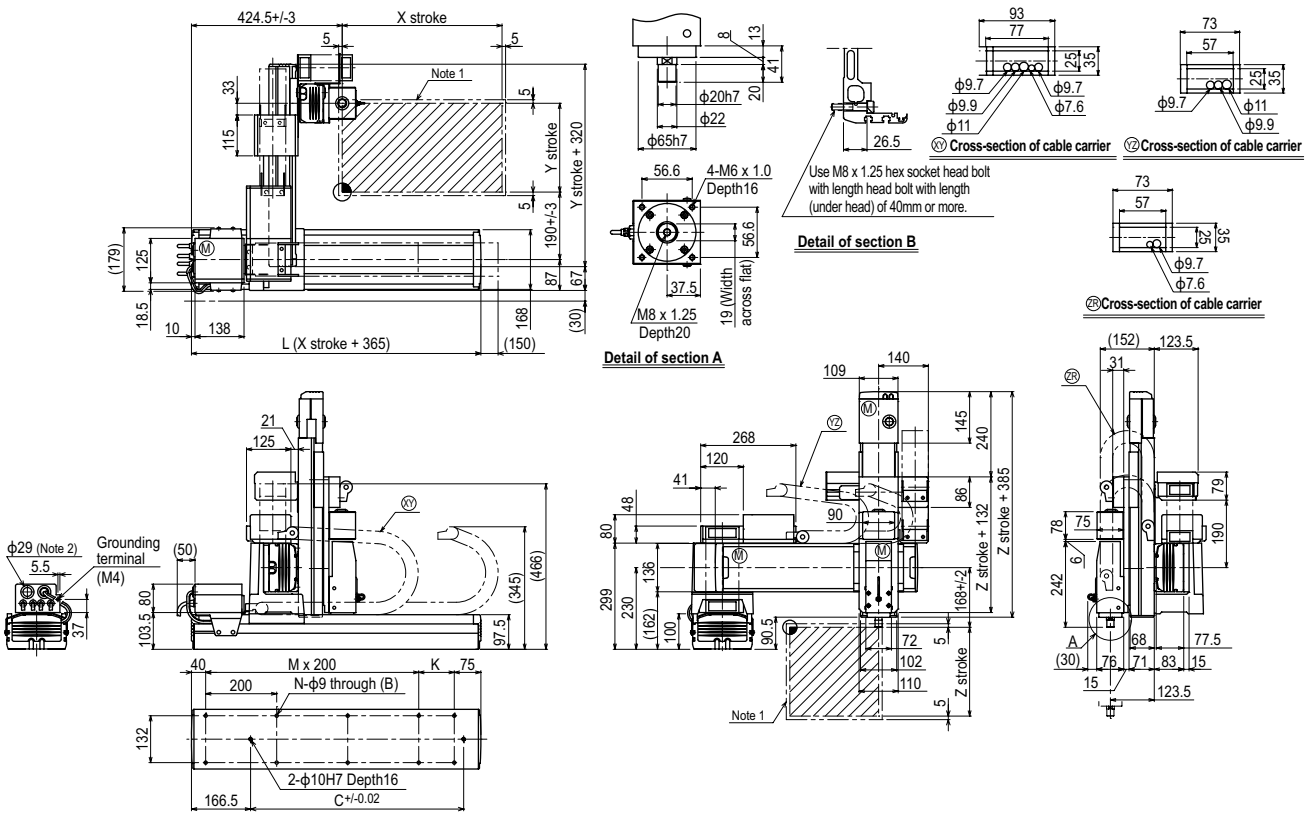

	X stroke	250	350	450	550	650	750	850	950	1050	1150	1250	
L	615	715	815	915	1015	1115	1215	1315	1415	1515	1615		
K	100	200	100	200	100	200	100	200	100	200	100		
C	240	420	600	600	780	780	960	960	1140	1140	1320		
M	2	2	3	3	4	4	5	5	6	6	7		
N	8	8	10	10	12	12	14	14	16	16	18		
Y stroke		150	250	350	450	550	650						
Z stroke		150	250	350									
Maximum speed for each stroke (mm/sec) ^{Note 3}	X-axis	1200						960	840	720	600	480	
	Speed setting	-						80%	70%	60%	50%	40%	

Note 1. The moving range when returning to origin and the stop position when stopping by the mechanical stopper.
 Note 2. User cable extraction port.
 Note 3. When the X-axis stroke is longer than 850mm, resonance of the ball screw may occur depending on the operation conditions (critical speed). In this case, reduce the speed setting on the program by referring to the maximum speeds shown in the table at the left.

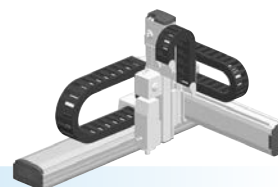

● Arm type ● Cable carrier ● Z-axis: clamped table / moving base type (200W)+R-axis

Ordering method

MXYx - C [] [] [] - **ZRFH** [] [] - **RCX340-4** [] [] [] [] [] [] [] [] [] [] [] []

Model	Cable	Combination	X-axis stroke	Y-axis stroke	ZR-axis	Z-axis stroke	Cable	Controller / Number of controllable axes	Safety standard	Option A (OP.A)	Option B (OP.B)	Option C (OP.C)	Option D (OP.D)	Option E (OP.E)	Absolute battery
A1			25 to 125cm	15 to 65cm		15 to 35cm	3L: 3.5m 5L: 5m 10L: 10m								
A2															
A3															
A4															

Specify various controller setting items. RCX340 ▶ **P.566**

Specification

	X-axis	Y-axis	Z-axis	R-axis
Axis construction ^{Note 1}	F17	F14H	F10H-BK	R5
AC servo motor output (W)	400	200	200	50
Repeatability ^{Note 2} (XYZ: mm)(R: °)	+/-0.01	+/-0.01	+/-0.01	+/-0.0083
Drive system	Ball screw φ20	Ball screw φ15	Ball screw φ15	Harmonic gear
Ball screw lead ^{Note 3} (Deceleration ratio) (mm)	20	20	10	(1/50)
Maximum speed ^{Note 4} (XYZ: mm/sec) (R: °/sec)	1200	1200	600	360
Moving range (XYZ: mm)(R: °)	250 to 1250	150 to 650	150 to 350	360
Robot cable length (m)	Standard: 3.5 Option: 5, 10			

Note. The standard types are ZRFH with higher rigidity as compared with ZRF types which are conventional standard types. When you need the ZRF type, please consult YAMAHA.

Note 1. Use caution that the flame machining (installation holes, tap holes) differs from single-axis robots.

Note 2. Positioning repeatability in one direction.

Note 3. Leads not listed in the catalog are also available. Contact us for details.

Note 4. When the X-axis stroke is longer than 850mm, resonance of the ball screw may occur depending on the operation conditions (critical speed). In this case, reduce the speed setting on the program by referring to the maximum speeds shown in the table below.

Maximum payload (kg)

Y stroke (mm)	Z stroke (mm)		
	150	250	350
150	11	9	8
250	11	9	8
350	11	9	8
450	8	7	6
550	8	7	6
650	4	3	2

Controller

Controller	Operation method
RCX340	Programming / I/O point trace / Remote command / Operation using RS-232C communication

MXYx 4 axes / ZRFH (A1)

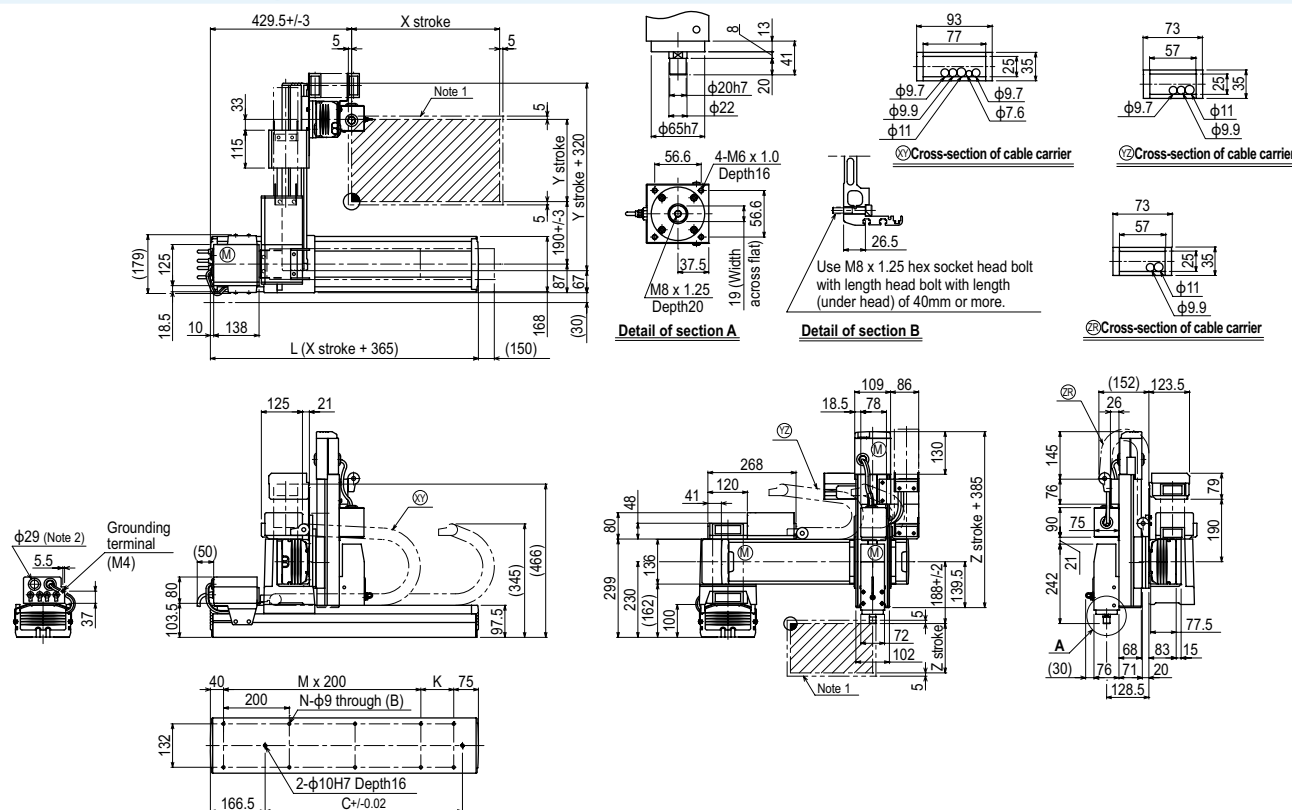

X stroke	250	350	450	550	650	750	850	950	1050	1150	1250	
	L	615	715	815	915	1015	1115	1215	1315	1415	1515	1615
K	100	200	100	200	100	200	100	200	100	200	100	
C	240	420	600	600	780	780	960	960	1140	1140	1320	
M	2	2	3	3	4	4	5	5	6	6	7	
N	8	8	10	10	12	12	14	14	16	16	18	
Y stroke	150	250	350	450	550	650						
Z stroke	150	250	350									
Maximum speed for each stroke (mm/sec) ^{Note 1}	X-axis		1200				960		840	720	600	480
	Speed setting		-				80%		70%	60%	50%	40%

Note 1. The moving range when returning to origin and the stop position when stopping by the mechanical stopper.

Note 2. User cable extraction port.

Note 3. When the X-axis stroke is longer than 850mm, resonance of the ball screw may occur depending on the operation conditions (critical speed). In this case, reduce the speed setting on the program by referring to the maximum speeds shown in the table at the left.

Articulated robots
YA

Linear conveyor
modules
LCMT100

Motor-less single
axis actuator
Robonity

Compact
single-axis robots
TRANSERVO

Single-axis robots
FLIP-X

Linear motor
single-axis robots
PHASER

Cartesian
robots
XY-X

SCARA
robots
YK-X

Pick & place
robots
YP-X

CLEAN

CONTROLLER

INFORMATION

Arm type

Gantry type

Moving arm
type

Pole type

XZ type

HXYx 2 axes

● Arm type ● Cable carrier



Ordering method

HXYx - C

Model	Cable	Combination	X-axis stroke	Y-axis stroke	Cable
A1			25 to 125cm	25 to 65cm	3L: 3.5m
A2					5L: 5m
A3					10L: 10m
A4					

RCX320-2

Controller / Number of controllable axes	Safety standard	Regenerative unit	Option A (OP.A)	Option B (OP.B)	Vision System	Absolute battery

Specify various controller setting items. RCX320 ▶ **P.548**

RCX222HP

Controller	Usable for CE	Regenerative unit	I/O selection 1	I/O selection 2

Specify various controller setting items. RCX222 ▶ **P.558**

Specification

	X-axis	Y-axis
Axis construction <small>Note 1</small>	F20	F17
AC servo motor output (W)	600	400
Repeatability <small>Note 2</small> (mm)	+/-0.01	+/-0.01
Drive system	Ball screw φ20	Ball screw φ20
Ball screw lead <small>Note 3</small> (Deceleration ratio) (mm)	20	20
Maximum speed <small>Note 4</small> (mm/sec)	1200	1200
Moving range (mm)	250 to 1250	250 to 650
Robot cable length (m)	Standard: 3.5 Option: 5,10	

Note 1. Use caution that the flame machining (installation holes, tap holes) differs from single-axis robots.
 Note 2. Positioning repeatability in one direction.
 Note 3. Leads not listed in the catalog are also available. Contact us for details.
 Note 4. When the X-axis stroke is longer than 850mm, resonance of the ball screw may occur depending on the operation conditions (critical speed). In this case, reduce the speed setting on the program by referring to the maximum speeds shown in the table below.

Maximum payload (kg)

Y stroke (mm)	XY 2 axes
250	40
350	40
450	35
550	30
650	30

Controller

Controller	Operation method
RCX320-R	Programming / I/O point trace / Remote command / Operation using RS-232C communication
RCX222HP-R	

HXYx 2 axes A1

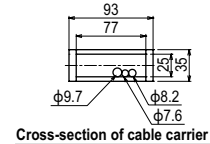
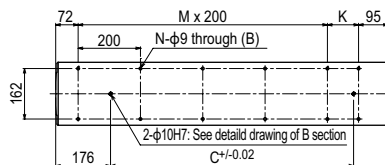
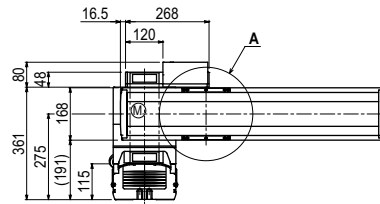
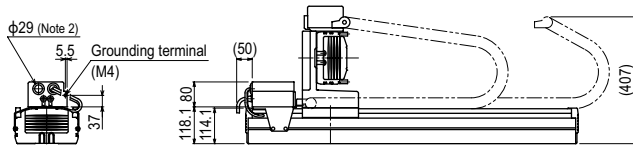
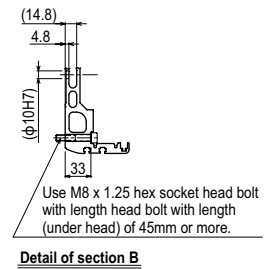
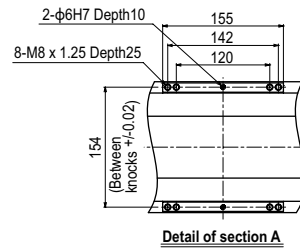
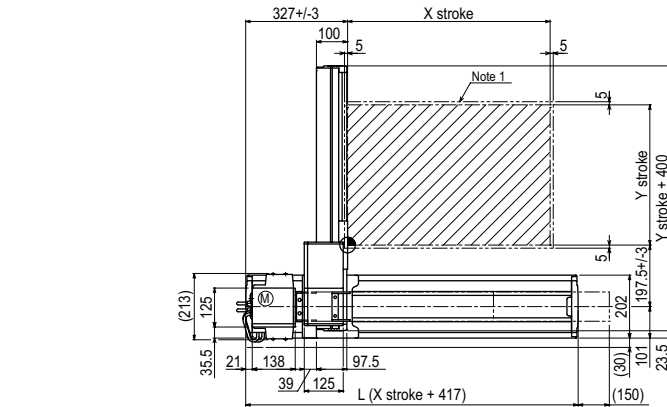

X stroke	250	350	450	550	650	750	850	950	1050	1150	1250
L	667	767	867	967	1067	1167	1267	1367	1467	1567	1667
K	100	200	100	200	100	200	100	200	100	200	100
C	420	420	600	600	780	780	960	960	1140	1320	1320
M	2	2	3	3	4	4	5	5	6	6	7
N	8	8	10	10	12	12	14	14	16	16	18
Y stroke	250	350	450	550	650						
Maximum speed for each stroke (mm/sec) <small>Note 3</small>	X-axis		1200				960	840	720	600	480
Speed setting			-				80%	70%	60%	50%	40%

Note 1. The moving range when returning to origin and the stop position when stopping by the mechanical stopper.
 Note 2. User cable extraction port.

Note 3. When the X-axis stroke is longer than 850mm, resonance of the ball screw may occur depending on the operation conditions (critical speed). In this case, reduce the speed setting on the program by referring to the maximum speeds shown in the table at the left.

HXYx 2 axes **A2**

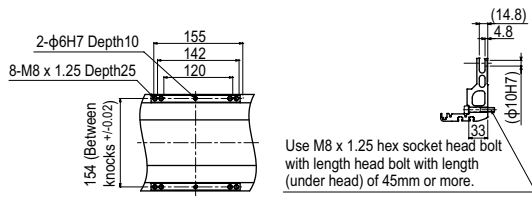

Detail of section A

Detail of section B

Use M8 x 1.25 hex socket head bolt with length head bolt with length (under head) of 45mm or more.

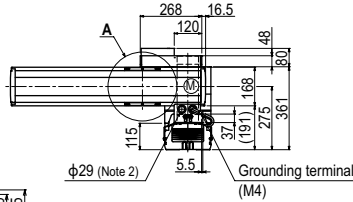

Cross-section of cable carrier

2-φ10H7: See detail drawing of B section

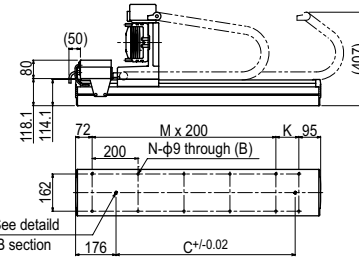
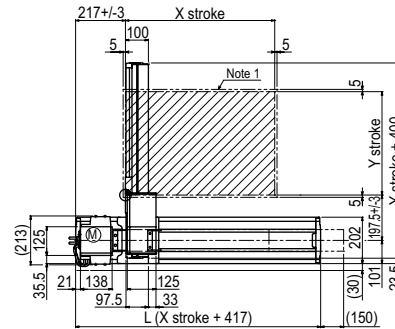

HXYx 2 axes **A3**

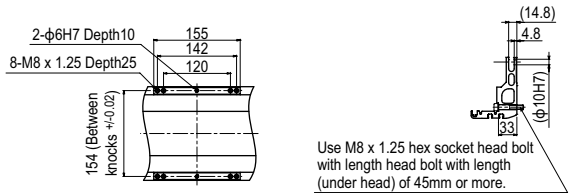

Detail of section A

Detail of section B

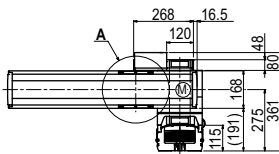

Cross-section of cable carrier

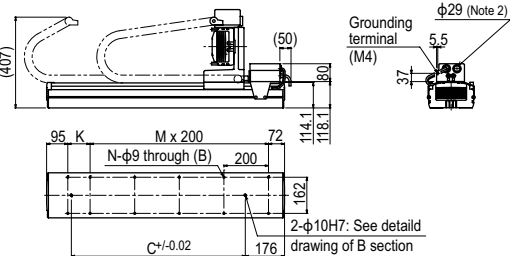
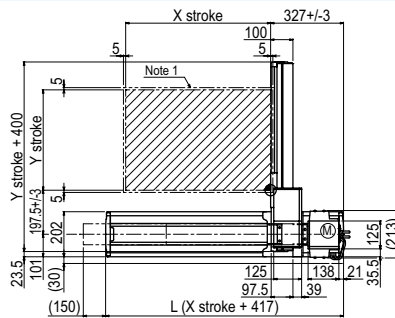

2-φ10H7: See detail drawing of B section

HXYx 2 axes **A4**

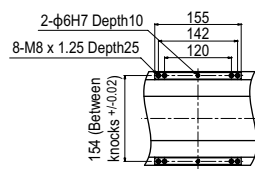
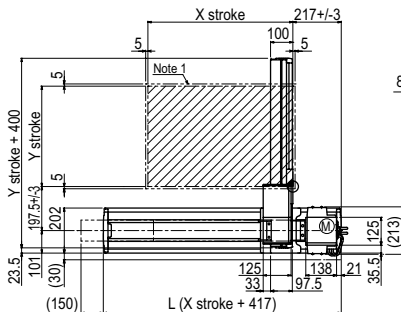

Detail of section A

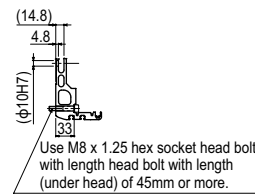

Detail of section B

Use M8 x 1.25 hex socket head bolt with length head bolt with length (under head) of 45mm or more.

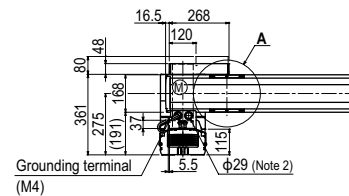
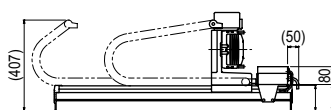

Cross-section of cable carrier

HXYx

3 axes / ZL

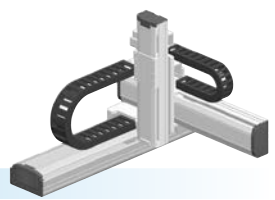

- Arm type
- Cable carrier
- Z-axis: clamped base / moving table type (200W)

Ordering method

HXYx - C [] [] [] **ZL** [] [] **RCX340-3** [] [] [] [] [] [] [] []

Model	Cable	Combination	X-axis stroke	Y-axis stroke	ZR-axis	Z-axis stroke	Cable	Controller / Number of controllable axes	Safety standard	Option A (OP.A)	Option B (OP.B)	Option C (OP.C)	Option D (OP.D)	Option E (OP.E)	Absolute battery
		A1	25 to 125cm	25 to 65cm		25 to 55cm	3L: 3.5m 5L: 5m 10L: 10m								

Specify various controller setting items. RCX340 ▶ **P.566**

Specification

	X-axis	Y-axis	Z-axis
Axis construction ^{Note 1}	F20	F17	F14H-BK
AC servo motor output (W)	600	400	200
Repeatability ^{Note 2} (mm)	+/-0.01	+/-0.01	+/-0.01
Drive system	Ball screw φ20	Ball screw φ20	Ball screw φ15
Ball screw lead ^{Note 3} (Deceleration ratio) (mm)	20	20	10
Maximum speed ^{Note 4} (mm/sec)	1200	1200	600
Moving range (mm)	250 to 1250	250 to 650	250 to 550
Robot cable length (m)	Standard: 3.5 Option: 5,10		

- Note 1. Use caution that the flame machining (installation holes, tap holes) differs from single-axis robots.
 Note 2. Positioning repeatability in one direction.
 Note 3. Leads not listed in the catalog are also available. Contact us for details.
 Note 4. When the X-axis stroke is longer than 850mm, resonance of the ball screw may occur depending on the operation conditions (critical speed). In this case, reduce the speed setting on the program by referring to the maximum speeds shown in the table below.

Maximum payload (kg)

Y stroke (mm)	Z stroke (mm)				
	250	350	450	550	650
250	20	20	20	20	20
350	20	20	20	20	20
450	20	20	19	18	
550	18	17	16	15	
650	18	17	16	15	

Controller

Controller	Operation method
RCX340	Programming / I/O point trace / Remote command / Operation using RS-232C communication

HXYx 3 axes / ZL (A1)

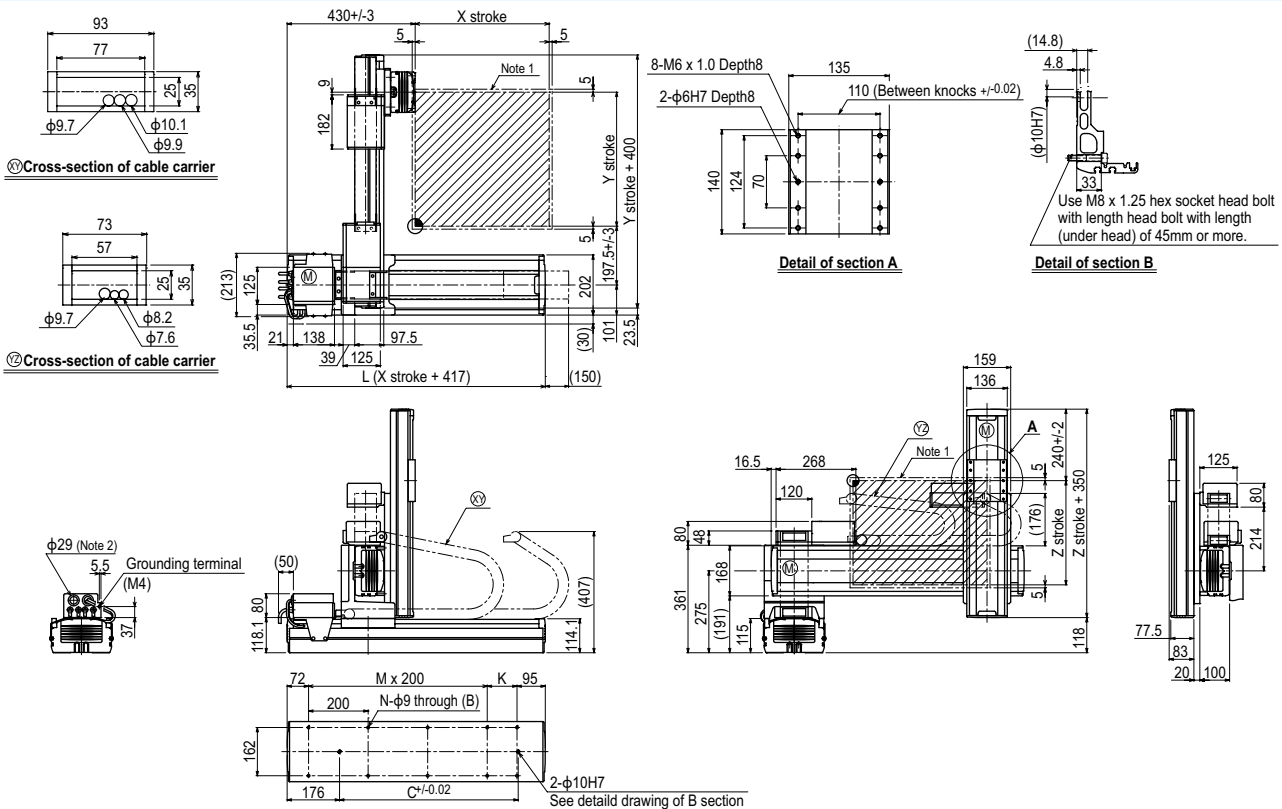

X stroke	250	350	450	550	650	750	850	950	1050	1150	1250
L	667	767	867	967	1067	1167	1267	1367	1467	1567	1667
K	100	200	100	200	100	200	100	200	100	200	100
C	420	420	600	600	780	780	960	960	1140	1320	1320
M	2	2	3	3	4	4	5	5	6	6	7
N	8	8	10	10	12	12	14	14	16	16	18
Y stroke	250	350	450	550	650						
Z stroke	250	350	450	550							
Maximum speed for each stroke (mm/sec) ^{Note 3}	X-axis		1200				960	840	720	600	480
Speed setting			-				80%	70%	60%	50%	40%

- Note 1. The moving range when returning to origin and the stop position when stopping by the mechanical stopper.
 Note 2. User cable extraction port.

- Note 3. When the X-axis stroke is longer than 850mm, resonance of the ball screw may occur depending on the operation conditions (critical speed). In this case, reduce the speed setting on the program by referring to the maximum speeds shown in the table at the left.

HXYx 3 axes / ZH

● Arm type ● Cable carrier ● Z-axis: clamped table / moving base type (200W)

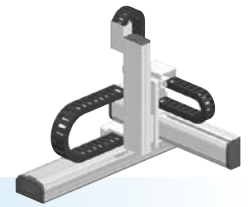

Ordering method

HXYx - C [] [] [] **ZH** [] [] **RCX340-3** [] [] [] [] [] [] [] [] [] [] []

Model	Cable	Combination	X-axis stroke	Y-axis stroke	ZR-axis	Z-axis stroke	Cable	Controller / Number of controllable axes	Safety standard	Option A (OP.A)	Option B (OP.B)	Option C (OP.C)	Option D (OP.D)	Option E (OP.E)	Absolute battery
A1			25 to 125cm	25 to 65cm		25 to 55cm	3L: 3.5m 5L: 5m 10L: 10m	Specify various controller setting items. RCX340 ▶ P.566							

Specification

	X-axis	Y-axis	Z-axis
Axis construction ^{Note 1}	F20	F17	F14H-BK
AC servo motor output (W)	600	400	200
Repeatability ^{Note 2} (mm)	+/-0.01	+/-0.01	+/-0.01
Drive system	Ball screw φ20	Ball screw φ20	Ball screw φ15
Ball screw lead ^{Note 3} (Deceleration ratio) (mm)	20	20	5
Maximum speed ^{Note 4} (mm/sec) (°/sec)	1200	1200	300
Moving range (mm)	250 to 1250	250 to 650	250 to 550
Robot cable length (m)	Standard: 3.5 Option: 5,10		

Note 1. Use caution that the flame machining (installation holes, tap holes) differs from single-axis robots.
 Note 2. Positioning repeatability in one direction.
 Note 3. Leads not listed in the catalog are also available. Contact us for details.
 Note 4. When the X-axis stroke is longer than 850mm, resonance of the ball screw may occur depending on the operation conditions (critical speed). In this case, reduce the speed setting on the program by referring to the maximum speeds shown in the table below.

Maximum payload (kg)

Y stroke (mm)	Z stroke (mm)			
	250	350	450	550
250	25	25	24	23
350	25	25	24	23
450	20	20	19	18
550	18	17	16	15
650	18	17	16	15

Controller

Controller	Operation method
RCX340	Programming / I/O point trace / Remote command / Operation using RS-232C communication

HXYx 3 axes / ZH A1

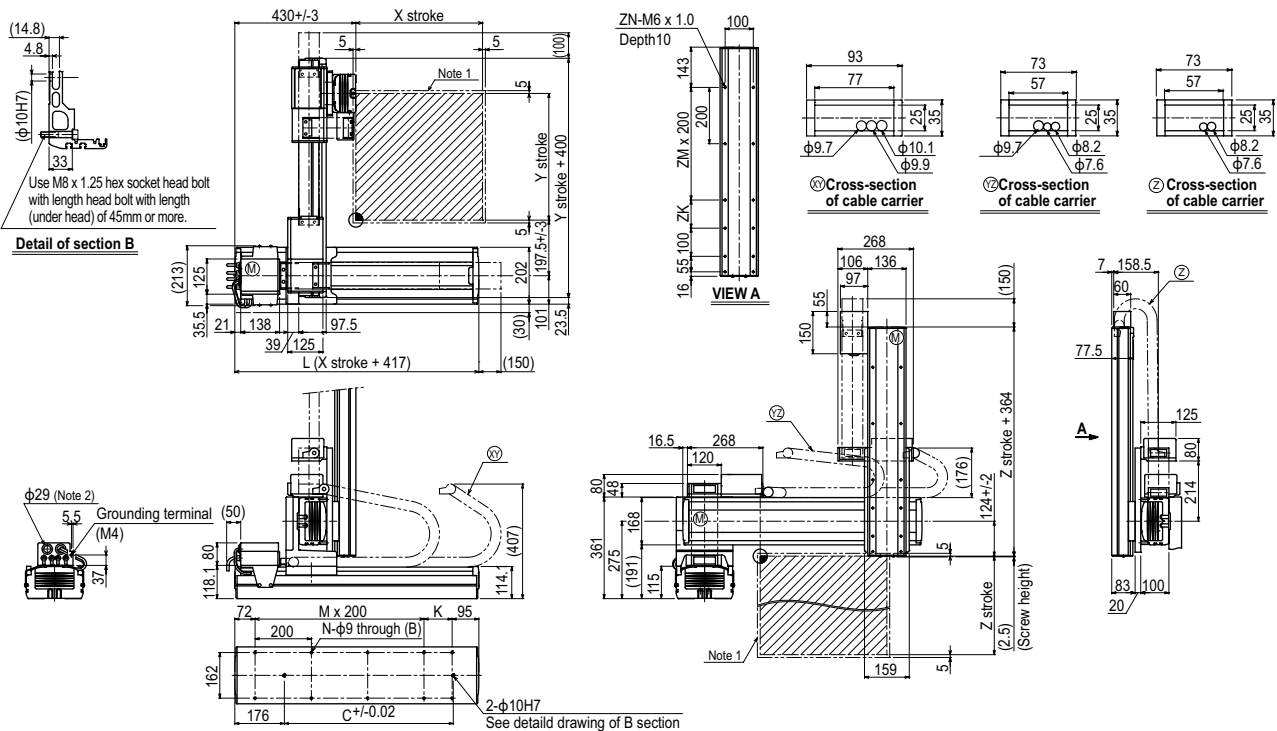

X stroke	250	350	450	550	650	750	850	950	1050	1150	1250	
	L	667	767	867	967	1067	1167	1267	1367	1467	1567	1667
K	100	200	100	200	100	200	100	200	100	200	100	
C	420	420	600	600	780	780	960	960	1140	1320	1320	
M	2	2	3	3	4	4	5	5	6	6	7	
N	8	8	10	10	12	12	14	14	16	16	18	
Y stroke	250	350	450	550	650							
Z stroke	250	350	450	550								
ZK	100	200	100	200								
ZM	1	1	2	2								
ZN	10	10	12	12								
Maximum speed for each stroke (mm/sec) ^{Note 3}	X-axis	1200					960	840	720	600	480	
Speed setting		-					80%	70%	60%	50%	40%	

Note 1. The moving range when returning to origin and the stop position when stopping by the mechanical stopper.
 Note 2. User cable extraction port.

Note 3. When the X-axis stroke is longer than 850mm, resonance of the ball screw may occur depending on the operation conditions (critical speed). In this case, reduce the speed setting on the program by referring to the maximum speeds shown in the table at the left.

Articulated robots
YA
Linear conveyor modules
LCM100
Motor-less single axis actuator
Robonity
Compact single-axis robots
TRANSEVO
Single-axis robots
FLIP-X
Linear motor single-axis robots
PHASER
Cartesian robots
XY-X
SCARA robots
YK-X
Pick & place robots
YP-X
CLEAN
CONTROLLER INFORMATION
Arm type
Gantry type
Moving arm type
Pole type
XZ type

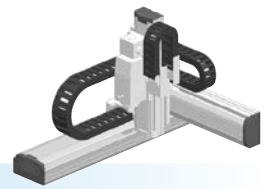

● Arm type ● Cable carrier ● Z-axis: clamped base / moving table type (200W)+R-axis

Ordering method

HXYx - C **ZRL** **RCX340-4**

Model	Cable	Combination	X-axis stroke	Y-axis stroke	ZR-axis	Z-axis stroke	Cable	Controller / Number of controllable axes	Safety standard	Option A (OP.A)	Option B (OP.B)	Option C (OP.C)	Option D (OP.D)	Option E (OP.E)	Absolute battery
		A1 A2 A3 A4	25 to 125cm	25 to 65cm		25 to 55cm	3L: 3.5m 5L: 5m 10L: 10m								

Specify various controller setting items. RCX340 ▶ **P.566**

Specification

	X-axis	Y-axis	Z-axis	R-axis
Axis construction ^{Note 1}	F20	F17	F14H-BK	R20
AC servo motor output (W)	600	400	200	200
Repeatability ^{Note 2} (XYZ: mm)(R: °)	+/-0.01	+/-0.01	+/-0.01	+/-0.0083
Drive system	Ball screw φ20	Ball screw φ20	Ball screw φ15	Harmonic gear
Ball screw lead ^{Note 3} (Deceleration ratio) (mm)	20	20	10	(1/50)
Maximum speed ^{Note 4} (XYZ: mm/sec) (R: °/sec)	1200	1200	600	360
Moving range (XYZ: mm) (R: °)	250 to 1250	250 to 650	250 to 550	360
Robot cable length (m)	Standard: 3.5 Option: 5, 10			

Note 1. Use caution that the flame machining (installation holes, tap holes) differs from single-axis robots.
 Note 2. Positioning repeatability in one direction.
 Note 3. Leads not listed in the catalog are also available. Contact us for details.
 Note 4. When the X-axis stroke is longer than 850mm, resonance of the ball screw may occur depending on the operation conditions (critical speed). In this case, reduce the speed setting on the program by referring to the maximum speeds shown in the table below.

Maximum payload (kg)

Y stroke (mm)	Z stroke (mm)			
	250	350	450	550
250	12	12	12	12
350	12	12	12	12
450	12	12	12	11
550	10	9	8	7
650	10	9	8	7

Controller

Controller	Operation method
RCX340	Programming / I/O point trace / Remote command / Operation using RS-232C communication

HXYx 4 axes / ZRL (A1)

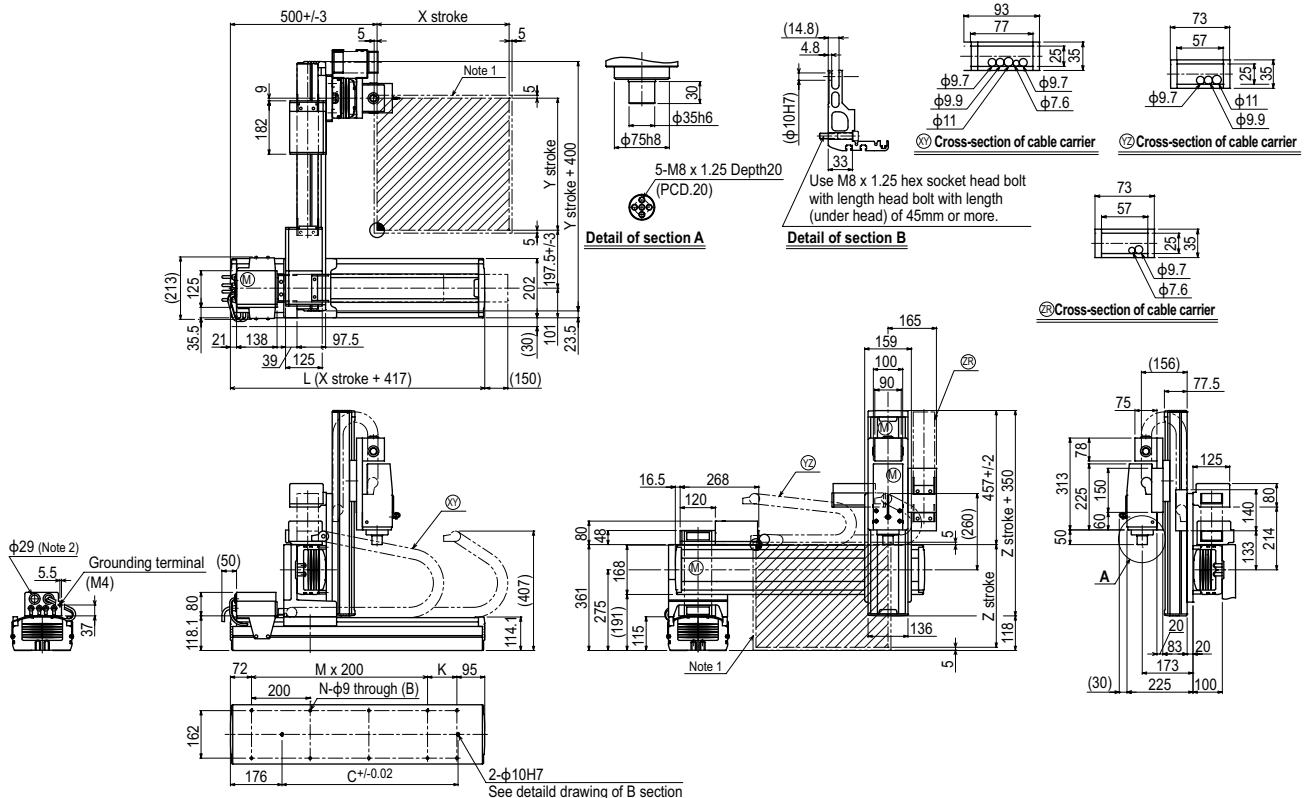

X stroke	250	350	450	550	650	750	850	950	1050	1150	1250
L	667	767	867	967	1067	1167	1267	1367	1467	1567	1667
K	100	200	100	200	100	200	100	200	100	200	100
C	420	420	600	600	780	780	960	960	1140	1320	1320
M	2	2	3	3	4	4	5	5	6	6	7
N	8	8	10	10	12	12	14	14	16	16	18
Y stroke	250	350	450	550	650						
Z stroke	250	350	450	550							
Maximum speed for each stroke (mm/sec) ^{Note 3}	X-axis		1200				960	840	720	600	480
Speed setting			-				80%	70%	60%	50%	40%

Note 1. The moving range when returning to origin and the stop position when stopping by the mechanical stopper.
 Note 2. User cable extraction port.

Note 3. When the X-axis stroke is longer than 850mm, resonance of the ball screw may occur depending on the operation conditions (critical speed). In this case, reduce the speed setting on the program by referring to the maximum speeds shown in the table at the left.

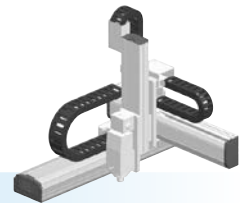

Ordering method

HXYx - C [] [] [] **ZRH** [] [] **RCX340-4** [] [] [] [] [] [] [] [] [] [] [] [] [] []

Model	Cable	Combination	X-axis stroke	Y-axis stroke	ZR-axis	Z-axis stroke	Cable	Controller / Number of controllable axes	Safety standard	Option A (OP.A)	Option B (OP.B)	Option C (OP.C)	Option D (OP.D)	Option E (OP.E)	Absolute battery
		A1	25 to 125cm	25 to 65cm		25 to 55cm	3L: 3.5m 5L: 5m 10L: 10m								

Specify various controller setting items. RCX340 ▶ **P.566**

Specification

	X-axis	Y-axis	Z-axis	R-axis
Axis construction ^{Note 1}	F20	F17	F14H-BK	R20
AC servo motor output (W)	600	400	200	200
Repeatability ^{Note 2} (XYZ: mm)(R: °)	+/-0.01	+/-0.01	+/-0.01	+/-0.0083
Drive system	Ball screw φ20	Ball screw φ20	Ball screw φ15	Harmonic gear
Ball screw lead ^{Note 3} (Deceleration ratio) (mm)	20	20	5	(1/50)
Maximum speed ^{Note 4} (XYZ: mm/sec) (R: °/sec)	1200	1200	300	360
Moving range (XYZ: mm) (R: °)	250 to 1250	250 to 650	250 to 550	360
Robot cable length (m)	Standard: 3.5 Option: 5, 10			

Note 1. Use caution that the flange machining (installation holes, tap holes) differs from single-axis robots.
 Note 2. Positioning repeatability in one direction.
 Note 3. Leads not listed in the catalog are also available. Contact us for details.
 Note 4. When the X-axis stroke is longer than 850mm, resonance of the ball screw may occur depending on the operation conditions (critical speed). In this case, reduce the speed setting on the program by referring to the maximum speeds shown in the table below.

Maximum payload (kg)

Y stroke (mm)	Z stroke (mm)			
	250	350	450	550
250	12	12	12	12
350	12	12	12	12
450	12	12	12	11
550	11	10	9	8
650	11	10	9	8

Controller

Controller	Operation method
RCX340	Programming / I/O point trace / Remote command / Operation using RS-232C communication

HXYx 4 axes / ZRH (A1)

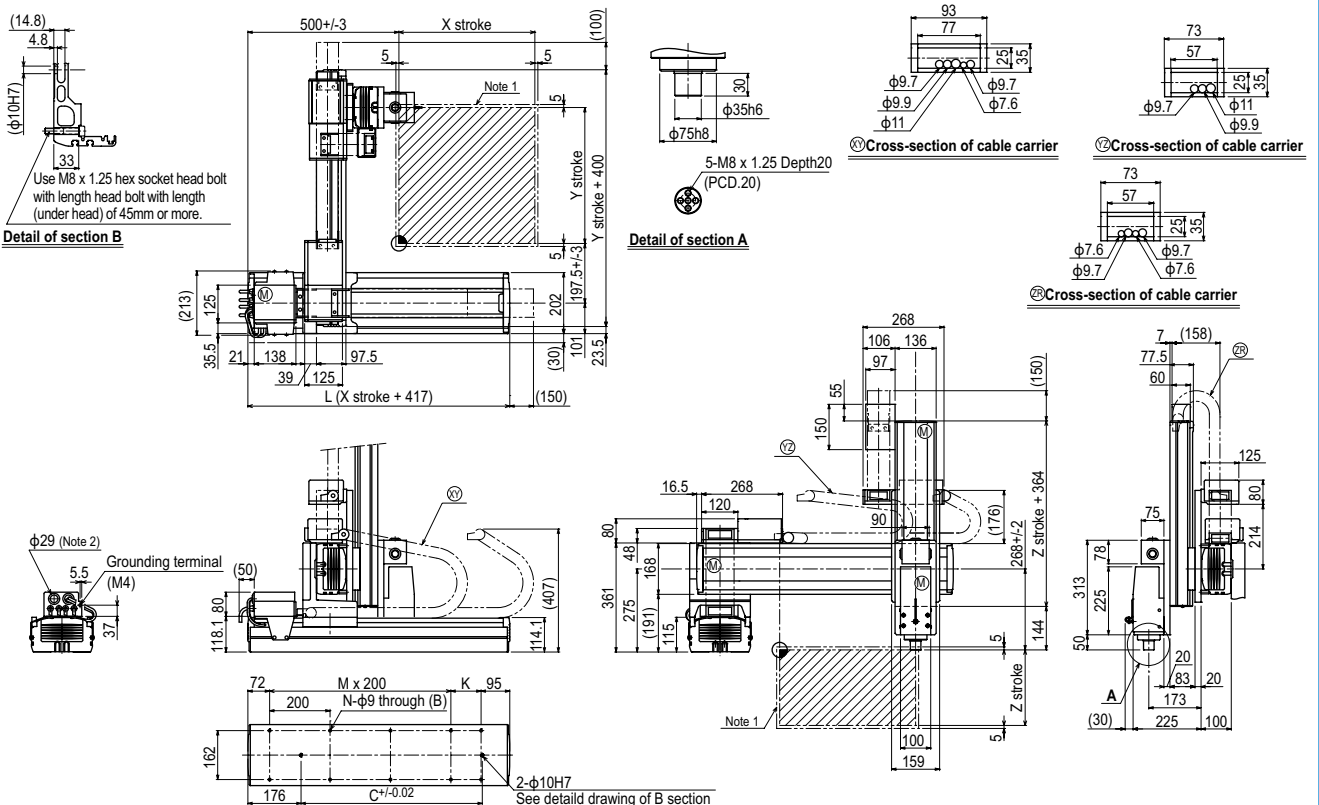

X stroke	250	350	450	550	650	750	850	950	1050	1150	1250	
	L	667	767	867	967	1067	1167	1267	1367	1467	1567	1667
K	100	200	100	200	100	200	100	200	100	200	100	
C	420	420	600	600	780	780	960	960	1140	1320	1320	
M	2	2	3	3	4	4	5	5	6	6	7	
N	8	8	10	10	12	12	14	14	16	16	18	
Y stroke	250	350	450	550	650							
Z stroke	250	350	450	550								
Maximum speed for each stroke (mm/sec) ^{Note 3}	X-axis	1200				960	840	720	600	480		
	Speed setting	-				80%	70%	60%	50%	40%		

Note 1. The moving range when returning to origin and the stop position when stopping by the mechanical stopper.
 Note 2. User cable extraction port.

Note 3. When the X-axis stroke is longer than 850mm, resonance of the ball screw may occur depending on the operation conditions (critical speed). In this case, reduce the speed setting on the program by referring to the maximum speeds shown in the table at the left.

HXYLx 2 axes

● Arm type ● Cable carrier



Ordering method

HXYLx - C **RCX320-2** **R**

Model	Cable	Combination	X-axis stroke	Y-axis stroke	Cable
A1			115 to 205cm	25 to 65cm	3L: 3.5m
A2					5L: 5m
A3					10L: 10m
A4					

RCX320-2 Controller / Number of controllable axes Safety standard Regenerative unit Option A (OP.A) Option B (OP.B) Vision System Absolute battery

Specify various controller setting items. RCX320 ▶ **P.548**

RCX222HP **R**

RCX222HP Controller Usable for CE Regenerative unit I/O selection 1 I/O selection 2

Specify various controller setting items. RCX222 ▶ **P.558**

Specification

	X-axis	Y-axis
Axis construction <small>Note 1</small>	F20N	F17
AC servo motor output (W)	400	400
Repeatability <small>Note 2</small> (mm)	+/-0.04	+/-0.01
Drive system	Ball screw φ20	Ball screw φ20
Ball screw lead <small>Note 3</small> (Deceleration ratio) (mm)	20	20
Maximum speed (mm/sec)	1200	1200
Moving range (mm)	1150 to 2050	250 to 650
Robot cable length (m)	Standard: 3.5 Option: 5,10	

Note 1. Use caution that the flange machining (installation holes, tap holes) differs from single-axis robots.
 Note 2. Positioning repeatability in one direction.
 Note 3. Leads not listed in the catalog are also available. Contact us for details.

Maximum payload (kg)

Y stroke (mm)	XY 2 axes
250	40
350	40
450	35
550	30
650	30

Controller

Controller	Operation method
RCX320-R	Programming / I/O point trace / Remote command / Operation using RS-232C communication
RCX222HP-R	

HXYLx 2 axes A1

Detail of section B

Detail of section A

Detail of section C

Cross-section of cable carrier

X stroke	1150	1250	1350	1450	1550	1650	1750	1850	1950	2050
L	1570	1670	1770	1870	1970	2070	2170	2270	2370	2470
D	528	574	620	666	712	758	804	850	896	942
K	100	200	100	200	100	200	100	200	100	200
M	7	7	8	8	9	9	10	10	11	11
N	18	18	20	20	22	22	24	24	26	26
Y stroke	250	350	450	550	650					

Note 1. The moving range when returning to origin and the stop position when stopping by the mechanical stopper.
 Note 2. The shaded position indicates a user cable extraction port.

HXYLx 2 axes **A2**

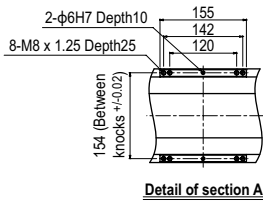

Detail of section A

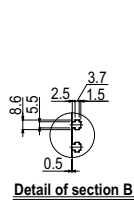

Detail of section B

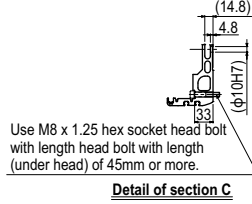

Detail of section C

Use M8 x 1.25 hex socket head bolt with length head bolt with length (under head) of 45mm or more.

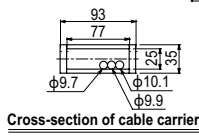
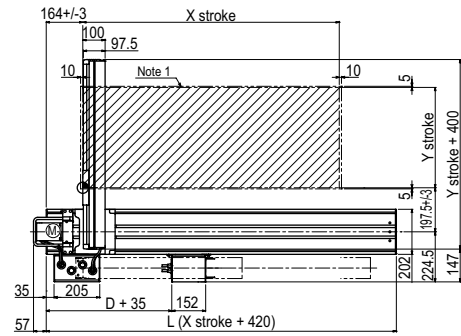

Cross-section of cable carrier

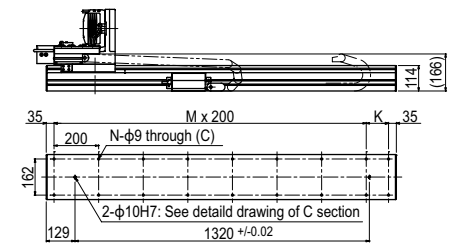
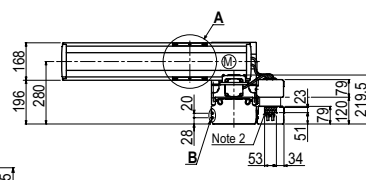

HXYLx 2 axes **A3**

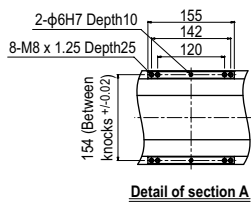

Detail of section A

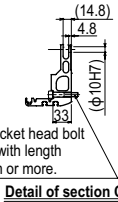

Detail of section C

Use M8 x 1.25 hex socket head bolt with length head bolt with length (under head) of 45mm or more.

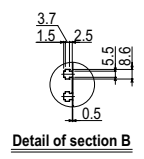
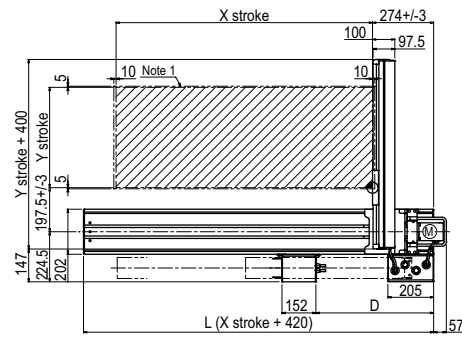

Detail of section B

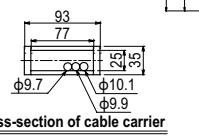

Cross-section of cable carrier

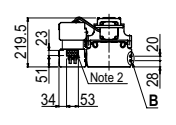
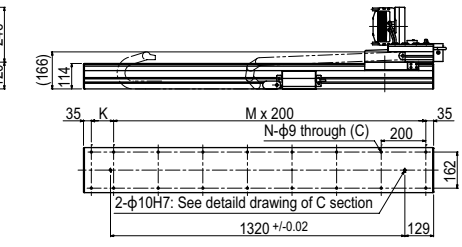
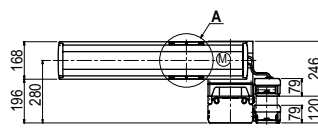

HXYLx 2 axes **A4**

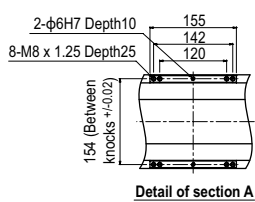
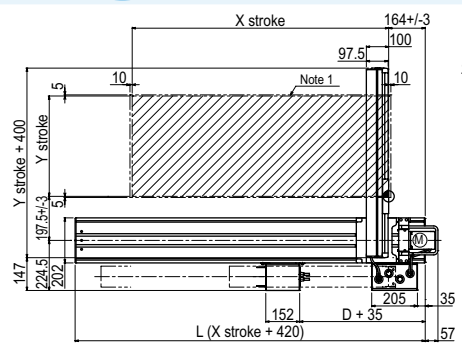

Detail of section A

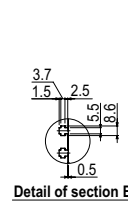

Detail of section B

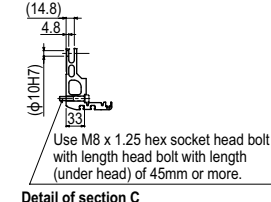

Detail of section C

Use M8 x 1.25 hex socket head bolt with length head bolt with length (under head) of 45mm or more.

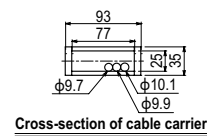

Cross-section of cable carrier

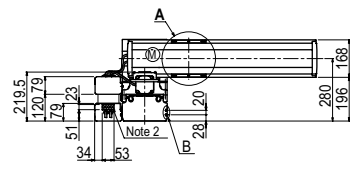
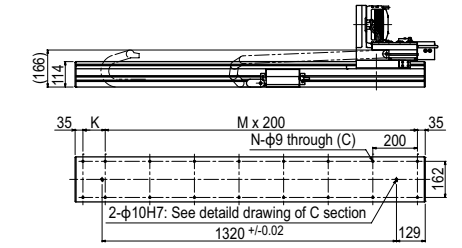

Articulated robots	YA
Linear conveyor modules	LCM100
Motor-less single axis actuator	Robonity
Compact single-axis robots	TRANSEVO
Single-axis robots	FLIP-X
Linear motor single-axis robots	PHASER
Cartesian robots	XX-X
SCARA robots	YK-X
Pick & place robots	YP-X
CLEAN	CLEAN
CONTROLLER	CONTROLLER
INFORMATION	INFORMATION
Arm type	Arm type
Gantry type	Gantry type
Moving arm type	Moving arm type
Pole type	Pole type
XZ type	XZ type

MXYx 2 axes

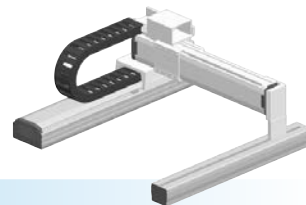

- Gantry type
- Cable carrier

Ordering method

MXYx - C

Model	Cable	Combination	X-axis stroke	Y-axis stroke	Cable
G1			25 to 125cm	15 to 85cm	3L: 3.5m
G2					5L: 5m
G3					10L: 10m
G4					

RCX320-2 **R**

Controller / Number of controllable axes	Safety standard	Regenerative unit	Option A (OP.A)	Option B (OP.B)	Vision System	Absolute battery
--	-----------------	-------------------	-----------------	-----------------	---------------	------------------

Specify various controller setting items. **RCX320 ▶ P.548**

RCX222 **R**

Controller	Usable for CE	Regenerative unit	I/O selection 1	I/O selection 2
------------	---------------	-------------------	-----------------	-----------------

Specify various controller setting items. **RCX222 ▶ P.558**

Specification

	X-axis	Y-axis
Axis construction <small>Note 1</small>	F17	F14H
AC servo motor output (W)	400	200
Repeatability <small>Note 2</small> (mm)	+/-0.01	+/-0.01
Drive system	Ball screw ϕ 20	Ball screw ϕ 15
Ball screw lead <small>Note 3</small> (Deceleration ratio) (mm)	20	20
Maximum speed <small>Note 4</small> (mm/sec)	1200	1200
Moving range (mm)	250 to 1250	150 to 850
Robot cable length (m)	Standard: 3.5 Option: 5, 10	

- Note 1. Use caution that the flame machining (installation holes, tap holes) differs from single-axis robots.
- Note 2. Positioning repeatability in one direction.
- Note 3. Leads not listed in the catalog are also available. Contact us for details.
- Note 4. When the X-axis stroke is longer than 850mm (750mm for Y-axis), resonance of the ball screw may occur depending on the operation conditions (critical speed). In this case, reduce the speed setting on the program by referring to the maximum speeds shown in the table below.

Maximum payload (kg)

Y stroke (mm)	XY 2 axes
150	30
250	30
350	30
450	30
550	30
650	30
750	25
850	20

Controller

Controller	Operation method
RCX320-R	Programming / I/O point trace / Remote command / Operation using RS-232C communication
RCX222-R	

MXYx 2 axes G1

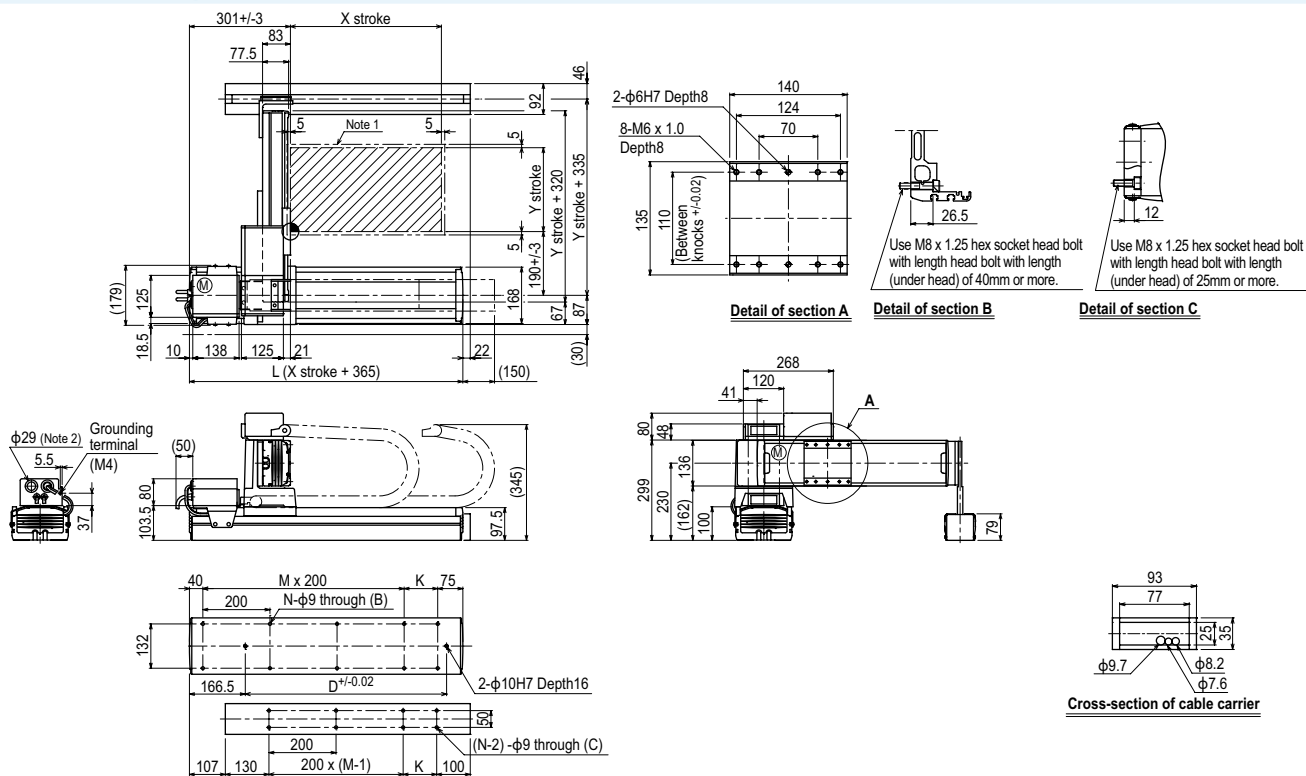

X stroke	250	350	450	550	650	750	850	950	1050	1150	1250
L	615	715	815	915	1015	1115	1215	1315	1415	1515	1615
K	100	200	100	200	100	200	100	200	100	200	100
D	240	420	600	600	780	780	960	960	1140	1140	1320
M	2	2	3	3	4	4	5	5	6	6	7
N	8	8	10	10	12	12	14	14	16	16	18
Y stroke	150	250	350	450	550	650	750	850			
Maximum speed for each stroke <small>Note 3</small> (mm/sec)	X-axis		1200		960		840	720	600	480	
	Speed setting		-		80%		70%	60%	50%	40%	
	Y-axis		1200		960		780				
	Speed setting		-		80%		65%				

- Note 1. The moving range when returning to origin and the stop position when stopping by the mechanical stopper.
- Note 2. User cable extraction port.

- Note 3. When the X-axis stroke is longer than 850mm (750mm for Y-axis), resonance of the ball screw may occur depending on the operation conditions (critical speed). In this case, reduce the speed setting on the program by referring to the maximum speeds shown in the table at the left.

MXyX 2 axes G2

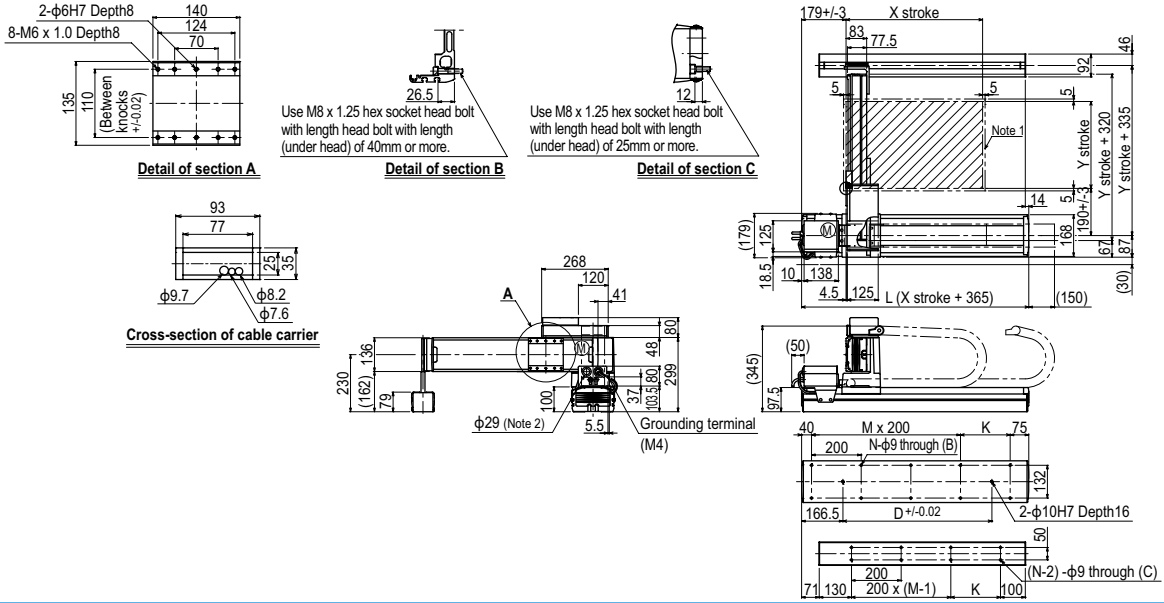

MXyX 2 axes G3

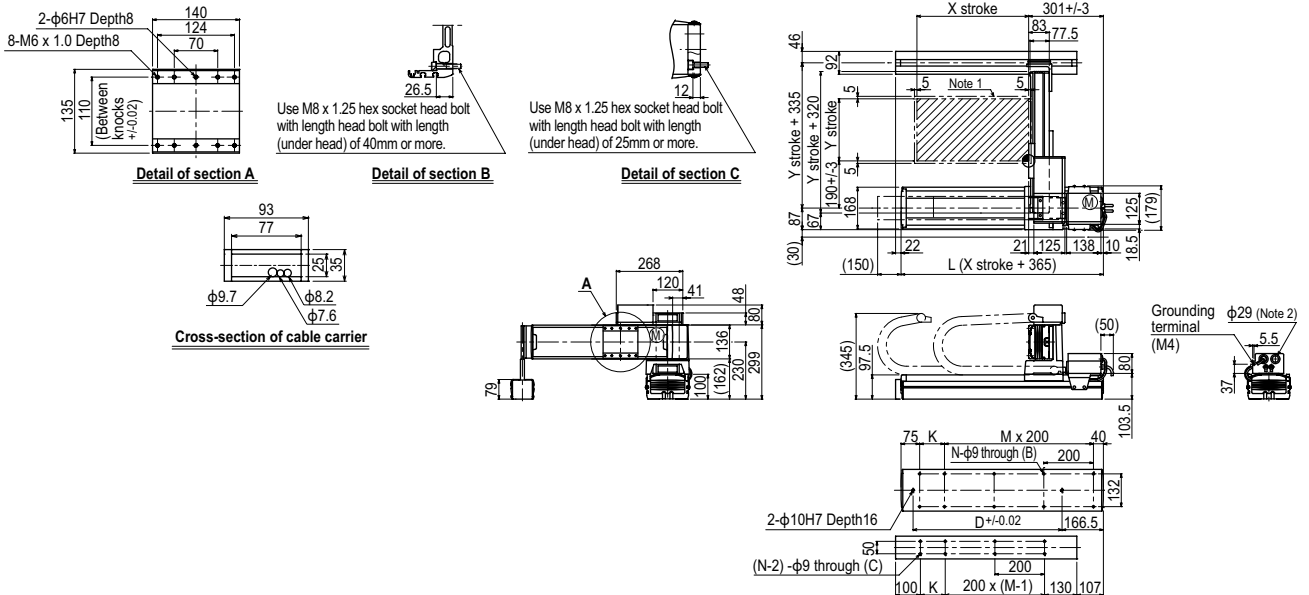

MXyX 2 axes G4

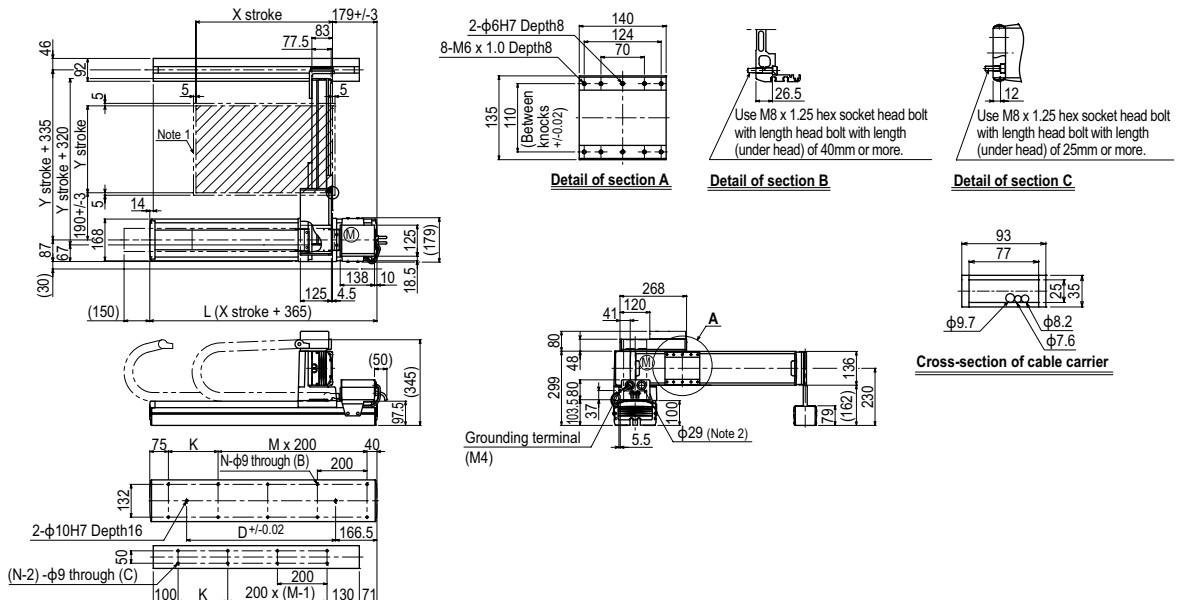

Articulated robots
YA

Linear conveyor modules
LCM100

Motor-less single axis actuator
Robonity

Compact single-axis robots
TRANSEVO

Single-axis robots
FLIP-X

Linear motor single-axis robots
PHASER

Cartesian robots
XY-X

SCARA robots
YK-X

Pick & place robots
YP-X

CLEAN INFORMATION

INFORMATION

Arm type

Gantry type

Moving arm type

Pole type

XZ type

MXYx 2 axes / IO

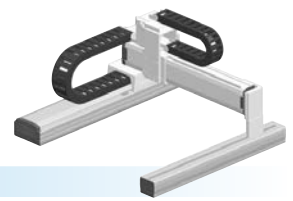

- Gantry type
- Cable carrier
- Type with Y-axis I/O cable carrier added

Ordering method

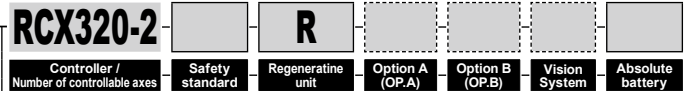
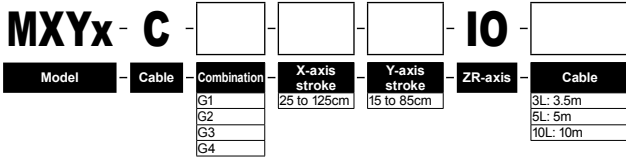

Specify various controller setting items. RCX320 ▶ P.548



Specify various controller setting items. RCX222 ▶ P.558

Specification

	X-axis	Y-axis
Axis construction ^{Note 1}	F17	F14H
AC servo motor output (W)	400	200
Repeatability ^{Note 2} (mm)	+/-0.01	+/-0.01
Drive system	Ball screw φ20	Ball screw φ15
Ball screw lead ^{Note 3} (Deceleration ratio) (mm)	20	20
Maximum speed ^{Note 4} (mm/sec)	1200	1200
Moving range (mm)	250 to 1250	150 to 850
Robot cable length (m)	Standard: 3.5 Option: 5,10	

Note 1. Use caution that the flame machining (installation holes, tap holes) differs from single-axis robots'.
 Note 2. Positioning repeatability in one direction.
 Note 3. Leads not listed in the catalog are also available. Contact us for details.
 Note 4. When the X-axis stroke is longer than 850mm (750mm for Y-axis), resonance of the ball screw may occur depending on the operation conditions (critical speed). In this case, reduce the speed setting on the program by referring to the maximum speeds shown in the table below.

Maximum payload (kg)

Y stroke (mm)	XY 2 axes
150	29
250	29
350	29
450	29
550	29
650	29
750	24
850	19

Controller

Controller	Operation method
RCX320-R	Programming / I/O point trace / Remote command / Operation using RS-232C communication
RCX222-R	

MXYx 2 axes / IO (G1)

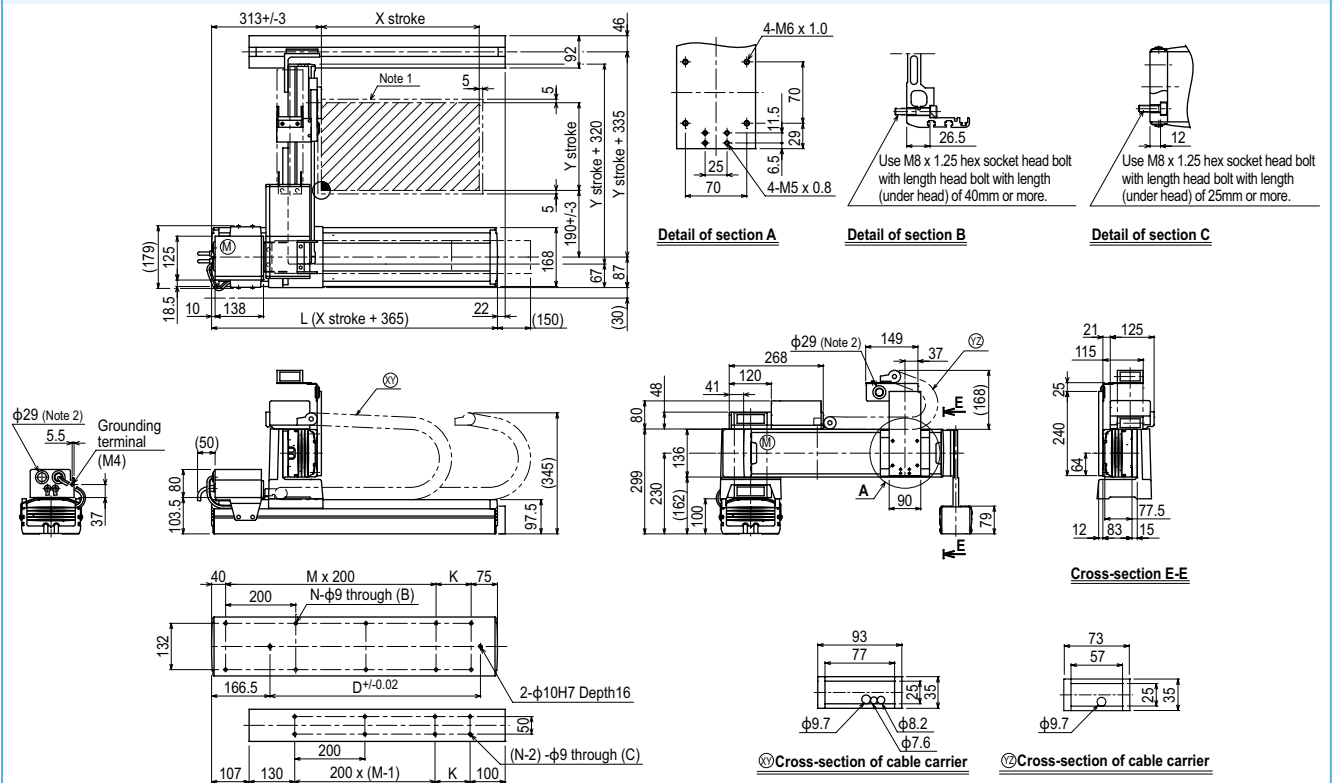

X stroke	250	350	450	550	650	750	850	950	1050	1150	1250
	L	615	715	815	915	1015	1115	1215	1315	1415	1515
K	100	200	100	200	100	200	100	200	100	200	100
D	240	420	600	600	780	780	960	960	1140	1140	1320
M	2	2	3	3	4	4	5	5	6	6	7
N	8	8	10	10	12	12	14	14	16	16	18
Y stroke	150	250	350	450	550	650	750	850			
Maximum speed for each stroke (mm/sec) ^{Note 3}	X-axis		1200				960	840	720	600	480
	Speed setting		-				80%	70%	60%	50%	40%
	Y-axis		1200				960	780			
	Speed setting		-				80%	65%			

Note 1. The moving range when returning to origin and the stop position when stopping by the mechanical stopper.
 Note 2. User cable extraction port.
 Note 3. When the X-axis stroke is longer than 850mm (750mm for Y-axis), resonance of the ball screw may occur depending on the operation conditions (critical speed). In this case, reduce the speed setting on the program by referring to the maximum speeds shown in the table at the left.

- Gantry type
- Cable carrier
- Z-axis: clamped base / moving table type (200W)

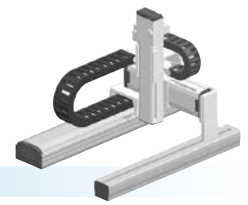

Ordering method

MXYx-C [] [] [] [] [] [] **RCX340-3** [] [] [] [] [] [] [] [] [] []

Model	Cable	Combination	X-axis stroke	Y-axis stroke	ZR-axis	Z-axis stroke	Cable	Controller / Number of controllable axes	Safety standard	Option A (OP.A)	Option B (OP.B)	Option C (OP.C)	Option D (OP.D)	Option E (OP.E)	Absolute battery
G1			25 to 125cm	15 to 85cm	ZFL20	15 to 35cm	3L: 3.5m 5L: 5m 10L: 10m								
G2					ZFL10										
G3															
G4															

Specify various controller setting items. RCX340 ▶ P.566

Specification

	X-axis	Y-axis	Z-axis: ZFL20	Z-axis: ZFL10
Axis construction ^{Note 1}	F17	F14H-BK	F10H-BK	
AC servo motor output (W)	400	200	200	
Repeatability ^{Note 2} (mm)	+/-0.01	+/-0.01	+/-0.01	
Drive system	Ball screw φ20	Ball screw φ15	Ball screw φ15	
Ball screw lead ^{Note 3} (Deceleration ratio) (mm)	20	20	20	10
Maximum speed ^{Note 4} (mm/sec)	1200	1200	1200	600
Moving range (mm)	250 to 1250	150 to 850	150 to 350	
Robot cable length (m)	Standard: 3.5 Option: 5,10			

- Note. The standard types are ZFL with higher rigidity as compared with ZF types which are conventional standard types. When you need the ZF type, please consult YAMAHA.
- Note 1. Use caution that the frame machining (installation holes, tap holes) differs from single-axis robots.
- Note 2. Positioning repeatability in one direction.
- Note 3. Leads not listed in the catalog are also available. Contact us for details.
- Note 4. When the X-axis stroke is longer than 850mm (750mm for Y-axis), resonance of the ball screw may occur depending on the operation conditions (critical speed). In this case, reduce the speed setting on the program by referring to the maximum speeds shown in the table below.

Maximum payload (kg)

Y stroke (mm)	Z stroke (mm)					
	ZFL20			ZFL10		
150	8	8	8	15	15	15
250	8	8	8	15	15	15
350	8	8	8	15	15	15
450	8	8	8	15	15	15
550	8	8	8	15	15	15
650	8	8	8	15	15	15
750	8	8	8	15	15	15
850	8	8	8	12	11	10

Controller

Controller	Operation method
RCX340	Programming / I/O point trace / Remote command / Operation using RS-232C communication

MXYx 3 axes / ZFL20/10 G1

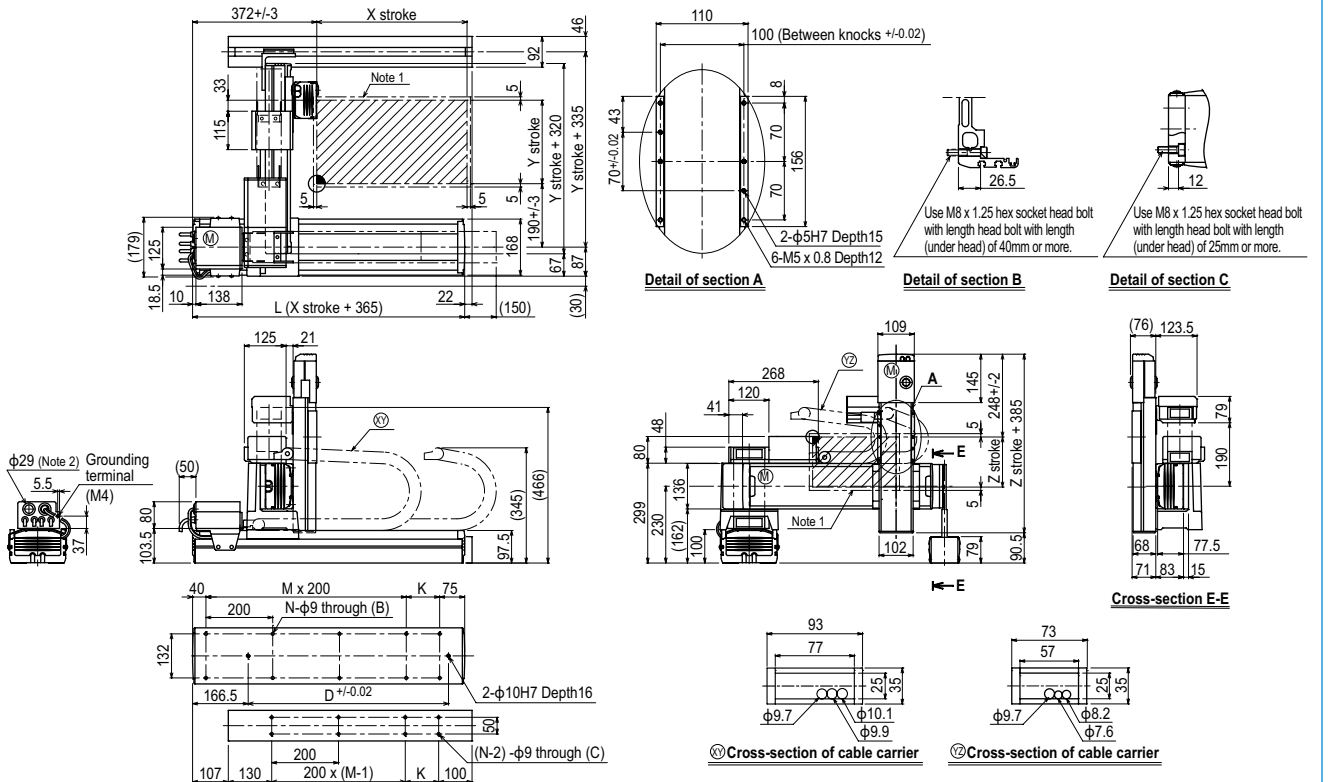

X stroke	250	350	450	550	650	750	850	950	1050	1150	1250	
	L	615	715	815	915	1015	1115	1215	1315	1415	1515	1615
K	100	200	100	200	100	200	100	200	100	200	100	
D	240	420	600	600	780	780	960	960	1140	1140	1320	
M	2	2	3	3	4	4	5	5	6	6	7	
N	8	8	10	10	12	12	14	14	16	16	18	
Y stroke	150	250	350	450	550	650	750	850				
Z stroke	150	250	350									
Maximum speed for each stroke (mm/sec) ^{Note 3}	X-axis											
	Speed setting	1200			960	840	720	600	480			
	Y-axis	1200			960	780						
	Speed setting	-			80%	65%						

- Note 1. The moving range when returning to origin and the stop position when stopping by the mechanical stopper.
- Note 2. User cable extraction port.
- Note 3. When the X-axis stroke is longer than 850mm (750mm for Y-axis), resonance of the ball screw may occur depending on the operation conditions (critical speed). In this case, reduce the speed setting on the program by referring to the maximum speeds shown in the table at the left.

Articulated robots
YA
Linear conveyor modules
LCM100
Motor-assisted single-axis robots
Robonity
Compact single-axis robots
TRANSEVO
Single-axis robots
FLIP-X
Linear motor single-axis robots
PHASER
Cartesian robots
XX-X
SCARA robots
YK-X
Pick & place robots
YP-X
CLEAN
CONTROLLER INFORMATION
Arm type
Gantry type
Moving arm type
Pole type
XZ type

MXYx 3 axes / ZFH

- Gantry type
- Cable carrier
- Z-axis: clamped table / moving base type (200W)

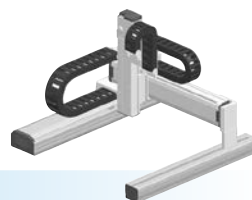

Ordering method

MXYx - C [] [] [] **ZFH** [] [] **RCX340-3** [] [] [] [] [] [] [] [] [] [] [] [] []

Model	Cable	Combination	X-axis stroke	Y-axis stroke	ZR-axis	Z-axis stroke	Cable	Controller / Number of controllable axes	Safety standard	Option A (OP.A)	Option B (OP.B)	Option C (OP.C)	Option D (OP.D)	Option E (OP.E)	Absolute battery
		G1	25 to 125cm	15 to 85cm		15 to 35cm	3L: 3.5m 5L: 5m 10L: 10m								

Specify various controller setting items. RCX340 ▶ **P.566**

Specification

	X-axis	Y-axis	Z-axis
Axis construction ^{Note 1}	F17	F14H	F10H-BK
AC servo motor output (W)	400	200	200
Repeatability ^{Note 2} (mm)	+/-0.01	+/-0.01	+/-0.01
Drive system	Ball screw φ20	Ball screw φ15	Ball screw φ15
Ball screw lead ^{Note 3} (Deceleration ratio) (mm)	20	20	10
Maximum speed ^{Note 4} (mm/sec)	1200	1200	600
Moving range (mm)	250 to 1250	150 to 850	150 to 350
Robot cable length (m)	Standard: 3.5 Option: 5,10		

Note. The standard types are ZFH with higher rigidity as compared with ZF types which are conventional standard types. When you need the ZF type, please consult YAMAHA.

Note 1. Use caution that the frame machining (installation holes, tap holes) differs from single-axis robots.

Note 2. Positioning repeatability in one direction.

Note 3. Leads not listed in the catalog are also available. Contact us for details.

Note 4. When the X-axis stroke is longer than 850mm (750mm for Y-axis), resonance of the ball screw may occur depending on the operation conditions (critical speed). In this case, reduce the speed setting on the program by referring to the maximum speeds shown in the table below.

Maximum payload (kg)

Y stroke (mm)	Z stroke (mm)		
	150	250	350
150	14	13	12
250	14	13	12
350	14	13	12
450	14	13	12
550	14	13	12
650	14	13	12
750	14	13	12
850	12	11	10

Controller

Controller	Operation method
RCX340	Programming / I/O point trace / Remote command / Operation using RS-232C communication

MXYx 3 axes / ZFH G1

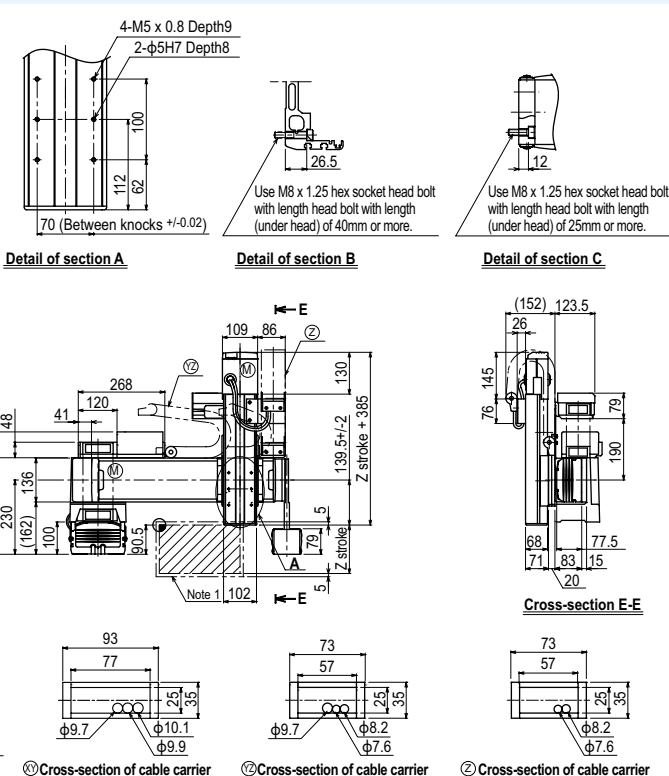
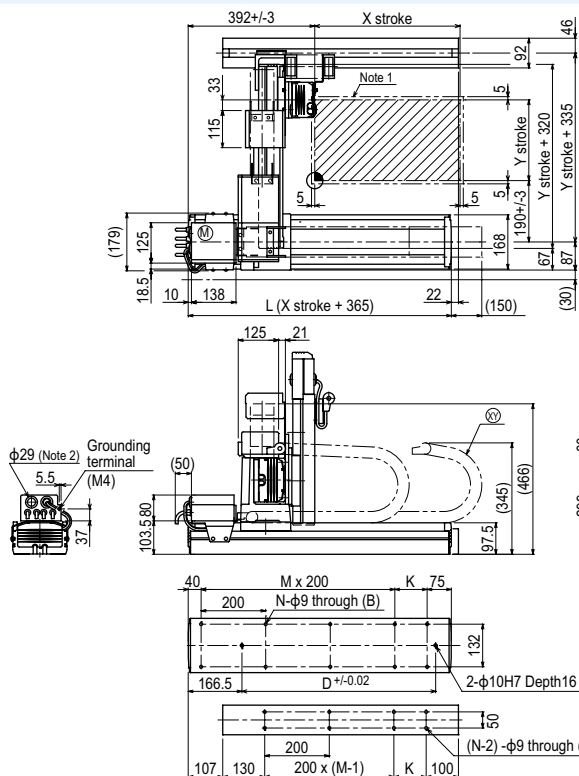

X stroke	250	350	450	550	650	750	850	950	1050	1150	1250	
	L	615	715	815	915	1015	1115	1215	1315	1415	1515	1615
K	100	200	100	200	100	200	100	200	100	200	100	
D	240	420	600	600	780	780	960	960	1140	1140	1320	
M	2	2	3	3	4	4	5	5	6	6	7	
N	8	8	10	10	12	12	14	14	16	16	18	
Y stroke	150	250	350	450	550	650	750	850				
Z stroke	150	250	350									
Maximum speed for each stroke (mm/sec) ^{Note 3}	X-axis		1200				960	840	720	600	480	
	Speed setting		-				80%	70%	60%	50%	40%	
	Y-axis		1200				960	780				
	Speed setting		-				80%	65%				

Note 1. The moving range when returning to origin and the stop position when stopping by the mechanical stopper.

Note 2. User cable extraction port.

Note 3. When the X-axis stroke is longer than 850mm (750mm for Y-axis), resonance of the ball screw may occur depending on the operation conditions (critical speed). In this case, reduce the speed setting on the program by referring to the maximum speeds shown in the table at the left.

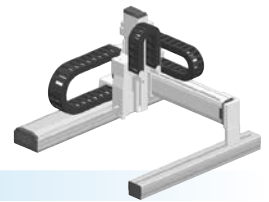

Ordering method

MXYx - C [] [] [] [] [] [] [] [] [] [] [] [] [] [] [] []

Model	Cable	Combination	X-axis stroke	Y-axis stroke	ZR-axis	Z-axis stroke	Cable	Controller / Number of controllable axes	Safety standard	Option A (OP.A)	Option B (OP.B)	Option C (OP.C)	Option D (OP.D)	Option E (OP.E)	Absolute battery
G1			25 to 125cm	15 to 85cm	ZRFL20	15 to 35cm	3L: 3.5m	RCX340-4	Safety standard	Option A (OP.A)	Option B (OP.B)	Option C (OP.C)	Option D (OP.D)	Option E (OP.E)	Absolute battery
G2					ZRFL10		5L: 5m								
G3							10L: 10m								
G4															

Specify various controller setting items. RCX340 ▶ P.566

Specification

	X-axis	Y-axis	Z-axis: ZRFL20	Z-axis: ZRFL10	R-axis
Axis construction ^{Note 1}	F17	F14H	F10H-BK	F10H-BK	R5
AC servo motor output (W)	400	200	200	200	50
Repeatability ^{Note 2} (XYZ: mm)(R: °)	+/-0.01	+/-0.01	+/-0.01	+/-0.01	+/-0.0083
Drive system	Ball screw φ20	Ball screw φ15	Ball screw φ15	Ball screw φ15	Harmonic gear
Ball screw lead ^{Note 3} (Deceleration ratio) (mm)	20	20	20	10	(1/50)
Maximum speed ^{Note 4} (XYZ: mm/sec) (R: °/sec)	1200	1200	1200	600	360
Moving range (XYZ: mm)(R: °)	250 to 1250	150 to 850	150 to 350	150 to 350	360
Robot cable length (m)	Standard: 3.5 Option: 5,10				

Note. The standard types are ZRFL with higher rigidity as compared with ZRF types which are conventional standard types. When you need the ZRF type, please consult YAMAHA.

Note 1. Use caution that the frame machining (installation holes, tap holes) differs from single-axis robots.

Note 2. Positioning repeatability in one direction.

Note 3. Leads not listed in the catalog are also available. Contact us for details.

Note 4. When the X-axis stroke is longer than 850mm (750mm for Y-axis), resonance of the ball screw may occur depending on the operation conditions (critical speed). In this case, reduce the speed setting on the program by referring to the maximum speeds shown in the table below.

Maximum payload (kg)

Y stroke (mm)	Z stroke (mm)					
	ZRFL20			ZRFL10		
150	4	4	4	11	11	11
250	4	4	4	11	11	11
350	4	4	4	11	11	11
450	4	4	4	11	11	11
550	4	4	4	11	11	11
650	4	4	4	11	11	11
750	4	4	4	11	11	11
850	4	4	4	8	7	6

Controller

Controller	Operation method
RCX340	Programming / I/O point trace / Remote command / Operation using RS-232C communication

MXYx 4 axes / ZRFL20/10 G1

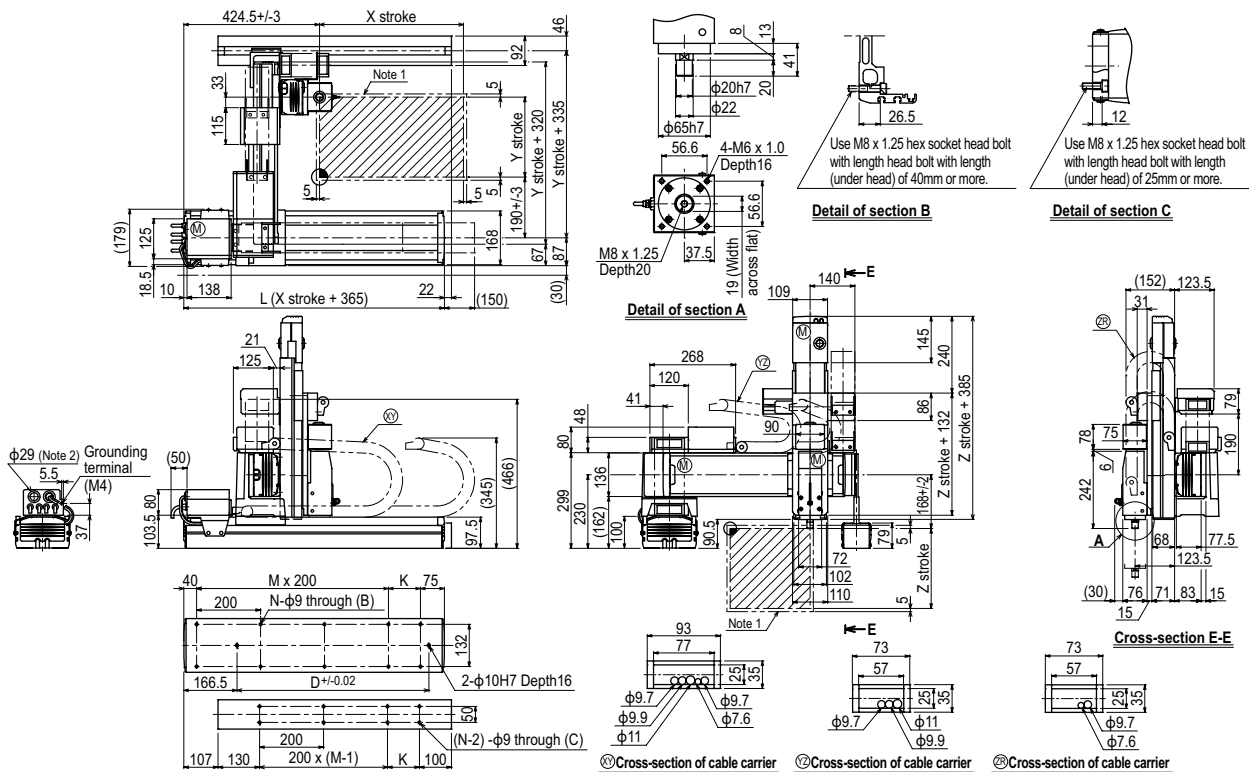

X stroke	250	350	450	550	650	750	850	950	1050	1150	1250
L	615	715	815	915	1015	1115	1215	1315	1415	1515	1615
K	100	200	100	200	100	200	100	200	100	200	100
D	240	420	600	600	780	780	960	960	1140	1140	1320
M	2	2	3	3	4	4	5	5	6	6	7
N	8	8	10	10	12	12	14	14	16	16	18

Y stroke	150	250	350	450	550	650	750	850
Z stroke	150	250	350					

Maximum speed for each stroke (mm/sec) ^{Note 3}	X-axis	1200	960	840	720	600	480	
	Speed setting	-	80%	70%	60%	50%	40%	
	Y-axis	1200	960	780				
Speed setting	-	80%	65%					

Note 1. The moving range when returning to origin and the stop position when stopping by the mechanical stopper.

Note 2. User cable extraction port.

Note 3. When the X-axis stroke is longer than 850mm (750mm for Y-axis), resonance of the ball screw may occur depending on the operation conditions (critical speed). In this case, reduce the speed setting on the program by referring to the maximum speeds shown in the table at the left.

MXy_x

4 axes / ZRFH

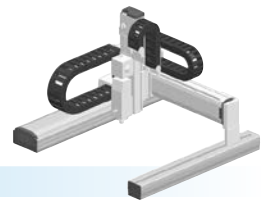

- Gantry type
- Cable carrier
- Z-axis: clamped table / moving base type (200W)+R-axis

Ordering method

MXy_x - C [] [] [] **ZRFH** [] [] **RCX340-4** [] [] [] [] [] [] [] [] [] []

Model	Cable	Combination	X-axis stroke	Y-axis stroke	ZR-axis	Z-axis stroke	Cable	Controller / Number of controllable axes	Safety standard	Option A (OP.A)	Option B (OP.B)	Option C (OP.C)	Option D (OP.D)	Option E (OP.E)	Absolute battery
		G1	25 to 125cm	15 to 85cm		15 to 35cm	3L: 3.5m 5L: 5m 10L: 10m								

Specify various controller setting items. RCX340 ▶ **P.566**

Specification

	X-axis	Y-axis	Z-axis	R-axis
Axis construction ^{Note 1}	F17	F14H	F10H-BK	R5
AC servo motor output (W)	400	200	200	50
Repeatability ^{Note 2} (XYZ: mm) (R: °)	+/-0.01	+/-0.01	+/-0.01	+/-0.0083
Drive system	Ball screw φ20	Ball screw φ15	Ball screw φ15	Harmonic gear
Ball screw lead ^{Note 3} (Deceleration ratio) (mm)	20	20	10	(1/50)
Maximum speed ^{Note 4} (XYZ: mm/sec) (R: °/sec)	1200	1200	600	360
Moving range (XYZ: mm) (R: °)	250 to 1250	150 to 850	150 to 350	360
Robot cable length (m)	Standard: 3.5 Option: 5, 10			

Note. The standard types are ZRFH with higher rigidity as compared with ZRF types which are conventional standard types. When you need the ZRF type, please consult YAMAHA.

Note 1. Use caution that the flame machining (installation holes, tap holes) differs from single-axis robots'.

Note 2. Positioning repeatability in one direction.

Note 3. Leads not listed in the catalog are also available. Contact us for details.

Note 4. When the X-axis stroke is longer than 850mm (750mm for Y-axis), resonance of the ball screw may occur depending on the operation conditions (critical speed). In this case, reduce the speed setting on the program by referring to the maximum speeds shown in the table below.

Maximum payload (kg)

Y stroke (mm)	Z stroke (mm)		
	150	250	350
150	10	9	8
250	10	9	8
350	10	9	8
450	10	9	8
550	10	9	8
650	10	9	8
750	10	9	8
850	8	7	6

Controller

Controller	Operation method
RCX340	Programming / I/O point trace / Remote command / Operation using RS-232C communication

MXy_x 4 axes / ZRFH G1

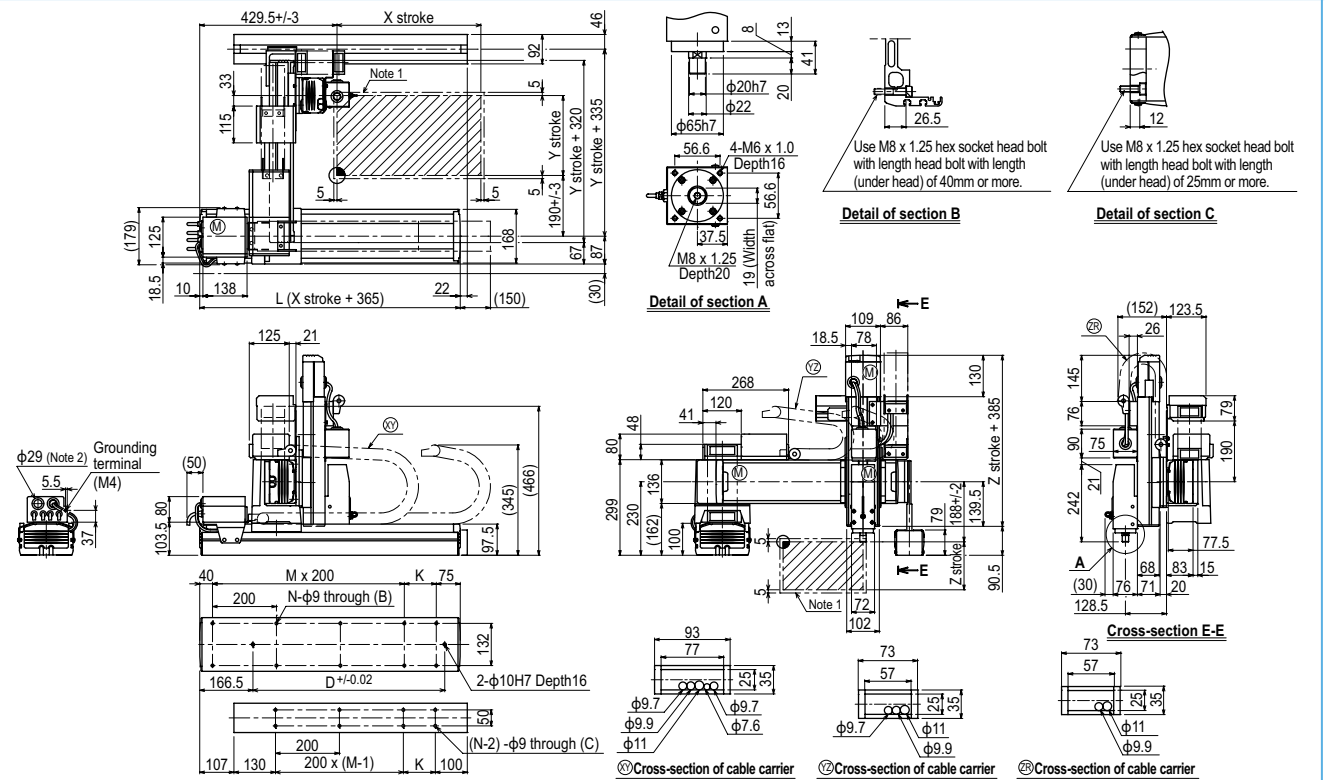

X stroke	250	350	450	550	650	750	850	950	1050	1150	1250	
	L	615	715	815	915	1015	1115	1215	1315	1415	1515	1615
K	100	200	100	200	100	200	100	200	100	200	100	
D	240	420	600	600	780	780	960	960	1140	1140	1320	
M	2	2	3	3	4	4	5	5	6	6	7	
N	8	8	10	10	12	12	14	14	16	16	18	
Y stroke	150	250	350	450	550	650	750	850				
Z stroke	150	250	350									
Maximum speed for each stroke (mm/sec) ^{Note 3}	X-axis		1200				960		840	720	600	480
	Speed setting		-				80%		70%	60%	50%	40%
	Y-axis		1200				960		780			
	Speed setting		-				80%		65%			

Note 1. The moving range when returning to origin and the stop position when stopping by the mechanical stopper.

Note 2. Use cable extraction port.

Note 3. When the X-axis stroke is longer than 850mm (750mm for Y-axis), resonance of the ball screw may occur depending on the operation conditions (critical speed). In this case, reduce the speed setting on the program by referring to the maximum speeds shown in the table at the left.

Articulated robots
YA

Linear conveyor
modules
LCM100

Motor-less single
axis actuator
Robonity

Compact
single-axis robots
TRANSERVO

Single-axis robots
FLIP-X

Linear motor
single-axis robots
PHASER

Cartesian
robots
XY-X

SCARA
robots
YK-X

Pick & place
robots
YP-X

CLEAN

CONTROLLER

INFORMATION

Arm type

Gantry type

Moving arm
type

Pole type

XZ type

HXYx 2 axes

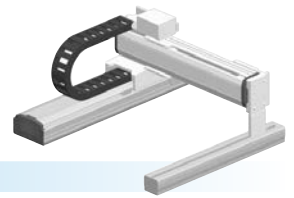

- Gantry type
- Cable carrier

Ordering method

HXYx - C

Model	Cable	Combination	X-axis stroke	Y-axis stroke	Cable
G1			25 to 125cm	25 to 105cm	3L: 3.5m
G2					5L: 5m
G3					10L: 10m
G4					

RCX320-2

Controller / Number of controllable axes	Safety standard	Regenerative unit	Option A (O.P.A)	Option B (O.P.B)	Vision System	Absolute battery
--	-----------------	-------------------	------------------	------------------	---------------	------------------

Specify various controller setting items. RCX320 ▶ **P.548**

RCX222HP

Controller	Usable for CE	Regenerative unit	I/O selection 1	I/O selection 2
------------	---------------	-------------------	-----------------	-----------------

Specify various controller setting items. RCX222 ▶ **P.558**

Specification

	X-axis	Y-axis
Axis construction <small>Note 1</small>	F20	F17
AC servo motor output (W)	600	400
Repeatability <small>Note 2</small> (mm)	+/-0.01	+/-0.01
Drive system	Ball screw φ20	Ball screw φ20
Ball screw lead <small>Note 3</small> (Deceleration ratio) (mm)	20	20
Maximum speed <small>Note 4</small> (mm/sec)	1200	1200
Moving range (mm)	250 to 1250	250 to 1050
Robot cable length (m)	Standard: 3.5 Option: 5,10	

- Note 1. Use caution that the flame machining (installation holes, tap holes) differs from single-axis robots'.
 Note 2. Positioning repeatability in one direction.
 Note 3. Leads not listed in the catalog are also available. Contact us for details.
 Note 4. When the X-axis/Y-axis stroke is longer than 850mm, resonance of the ball screw may occur depending on the operation conditions (critical speed). In this case, reduce the speed setting on the program by referring to the maximum speeds shown in the table below.

Maximum payload (kg)

Y stroke (mm)	XY 2 axes
250 to 1050	50

Controller

Controller	Operation method
RCX320-R	Programming / I/O point trace / Remote command / Operation using RS-232C communication
RCX222HP-R	

HXYx 2 axes G1

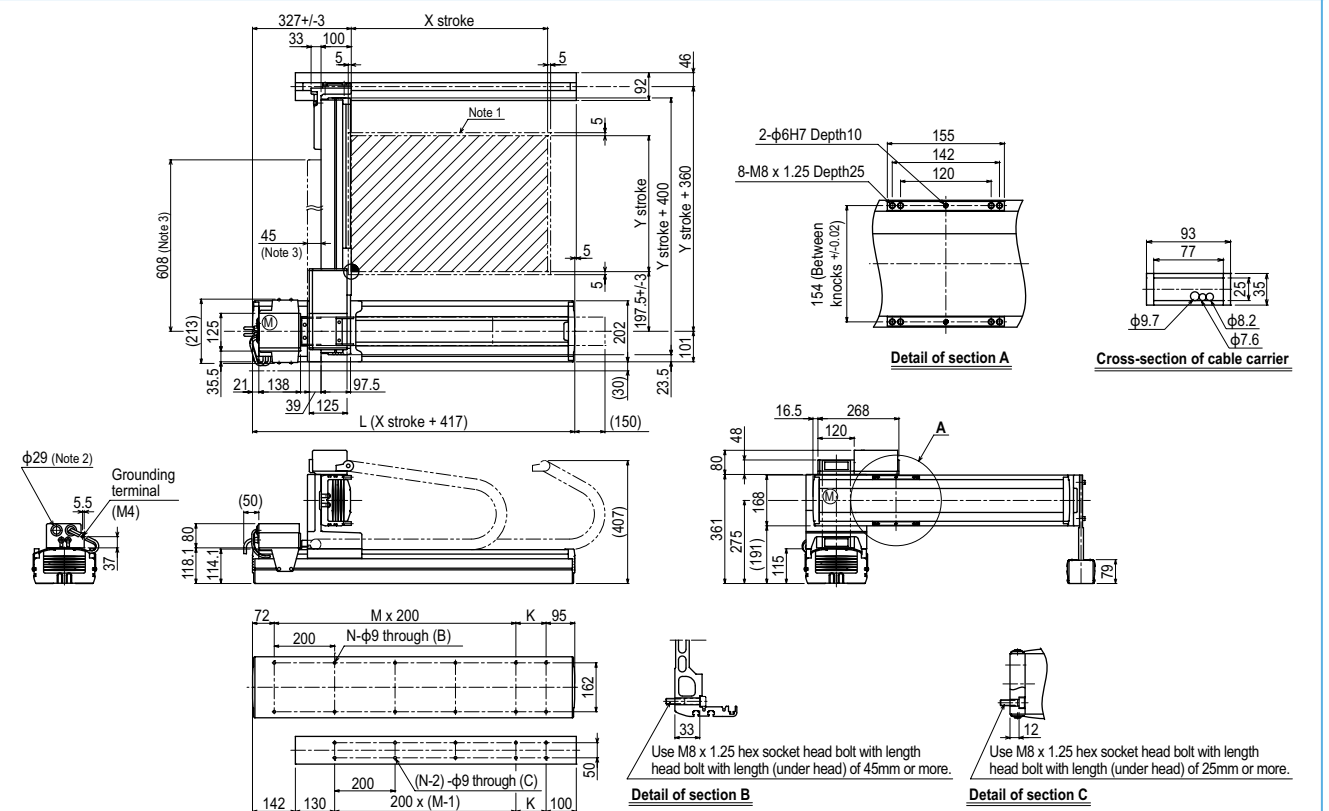

X stroke	Y stroke										
	250	350	450	550	650	750	850	950	1050	1250	
L	667	767	867	967	1067	1167	1267	1367	1467	1567	1667
K	100	200	100	200	100	200	100	200	100	200	100
F	420	420	600	600	780	780	960	960	1140	1320	1320
M	2	2	3	3	4	4	5	5	6	6	7
N	8	8	10	10	12	12	14	14	16	16	18
Y stroke	250	350	450	550	650	750	850	950	1050		
Maximum speed for each stroke (mm/sec) <small>Note 4</small>	X-axis	1200					960	840	720	600	480
	Y-axis	1200					960	840	720		
	Speed setting	-					80%	70%	60%	50%	40%

- Note 1. The moving range when returning to origin and the stop position when stopping by the mechanical stopper.
 Note 2. User cable extraction port.
 Note 3. Dimension of reinforced bracket (To be installed when the Y stroke is 750mm or longer)

Note 4. When the X-axis/Y-axis stroke is longer than 850mm, resonance of the ball screw may occur depending on the operation conditions (critical speed). In this case, reduce the speed setting on the program by referring to the maximum speeds shown in the table at the left.

HXYx 2 axes **G2**

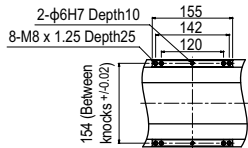

Detail of section A

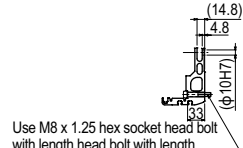

Detail of section B

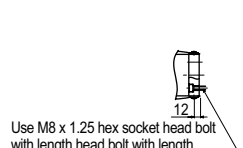

Detail of section C

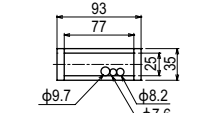

Cross-section of cable carrier

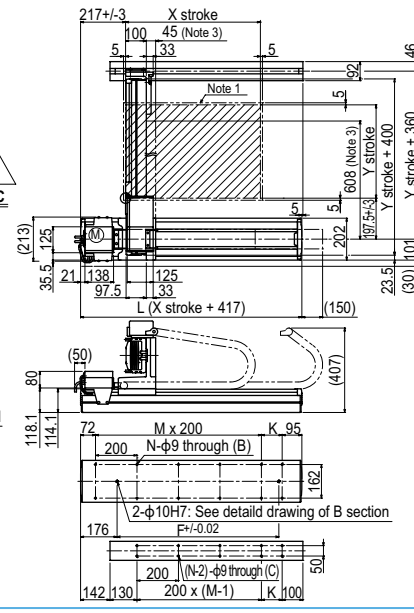
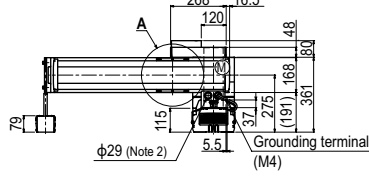

HXYx 2 axes **G3**

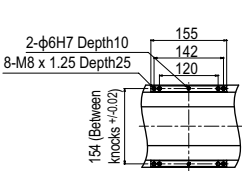

Detail of section A

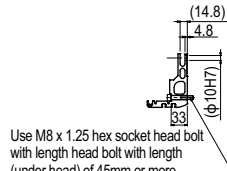

Detail of section B

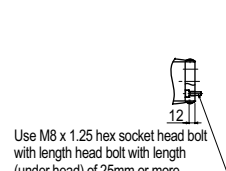

Detail of section C

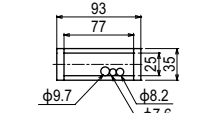

Cross-section of cable carrier

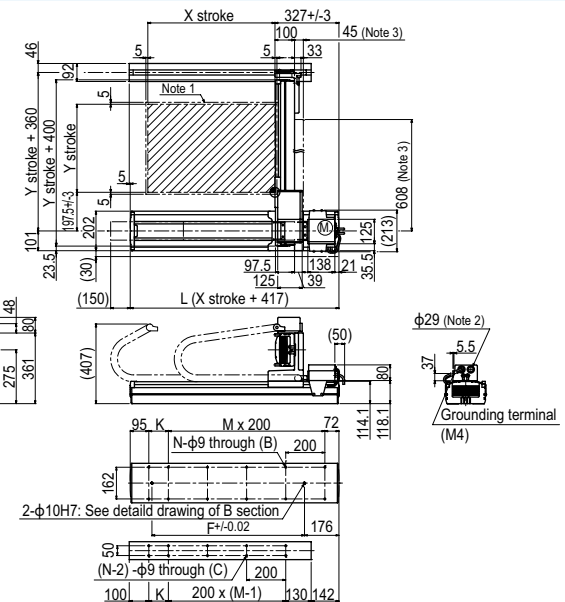
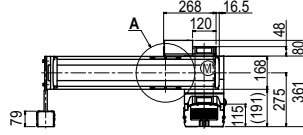

HXYx 2 axes **G4**

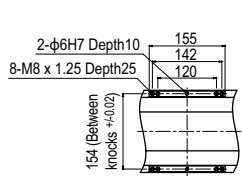
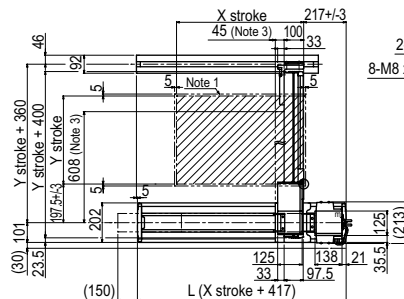

Detail of section A

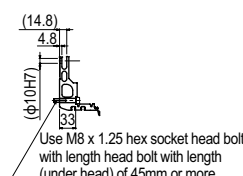

Detail of section B

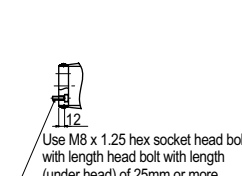

Detail of section C

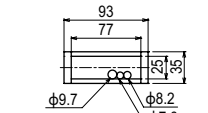
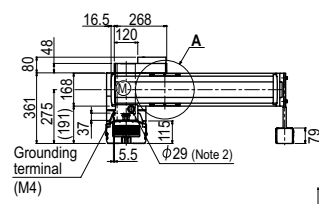

Cross-section of cable carrier

Articulated robots
YA
Linear conveyor modules
LCM100
Motor-less single axis actuator
Robonity
Compact single-axis robots
TRANSEVO
Single-axis robots
FLIP-X
Linear motor single-axis robots
PHASER
Cartesian robots
XY-X
SCARA robots
YK-X
Pick & place robots
YP-X
CLEAN INFORMATION
INFORMATION
Arm type
Gantry type
Moving arm type
Pole type
XZ type

HXYx **3 axes / ZL**

- Gantry type
- Cable carrier
- Z-axis: clamped base / moving table type (200W)

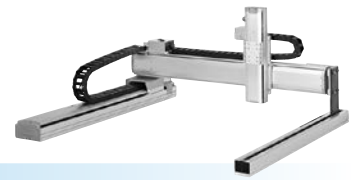

Ordering method

HXYx - C [] [] [] **ZL** [] [] **RCX340-3** [] [] [] [] [] [] [] [] [] [] [] []

Model	Cable	Combination	X-axis stroke	Y-axis stroke	ZR-axis	Z-axis stroke	Cable	Controller / Number of controllable axes	Safety standard	Option A (OP.A)	Option B (OP.B)	Option C (OP.C)	Option D (OP.D)	Option E (OP.E)	Absolute battery
		G1	25 to 125cm	25 to 105cm		25 to 55cm	3L: 3.5m 5L: 5m 10L: 10m								

Specify various controller setting items. RCX340 ▶ **P.566**

Specification

	X-axis	Y-axis	Z-axis
Axis construction ^{Note 1}	F20	F17	F14H-BK
AC servo motor output (W)	600	400	200
Repeatability ^{Note 2} (mm)	+/-0.01	+/-0.01	+/-0.01
Drive system	Ball screw φ20	Ball screw φ20	Ball screw φ15
Ball screw lead ^{Note 3} (Deceleration ratio) (mm)	20	20	10
Maximum speed ^{Note 4} (mm/sec)	1200	1200	600
Moving range (mm)	250 to 1250	250 to 1050	250 to 550
Robot cable length (m)	Standard: 3.5 Option: 5,10		

Note 1. Use caution that the flame machining (installation holes, tap holes) differs from single-axis robots.
 Note 2. Positioning repeatability in one direction.
 Note 3. Leads not listed in the catalog are also available. Contact us for details.
 Note 4. When the X-axis/Y-axis stroke is longer than 850mm, resonance of the ball screw may occur depending on the operation conditions (critical speed). In this case, reduce the speed setting on the program by referring to the maximum speeds shown in the table below.

Maximum payload (kg)

Y stroke (mm)	Z stroke (mm)
250 to 1050	250 to 550
	20

Controller

Controller	Operation method
RCX340	Programming / I/O point trace / Remote command / Operation using RS-232C communication

HXYx 3 axes / ZL (G1)

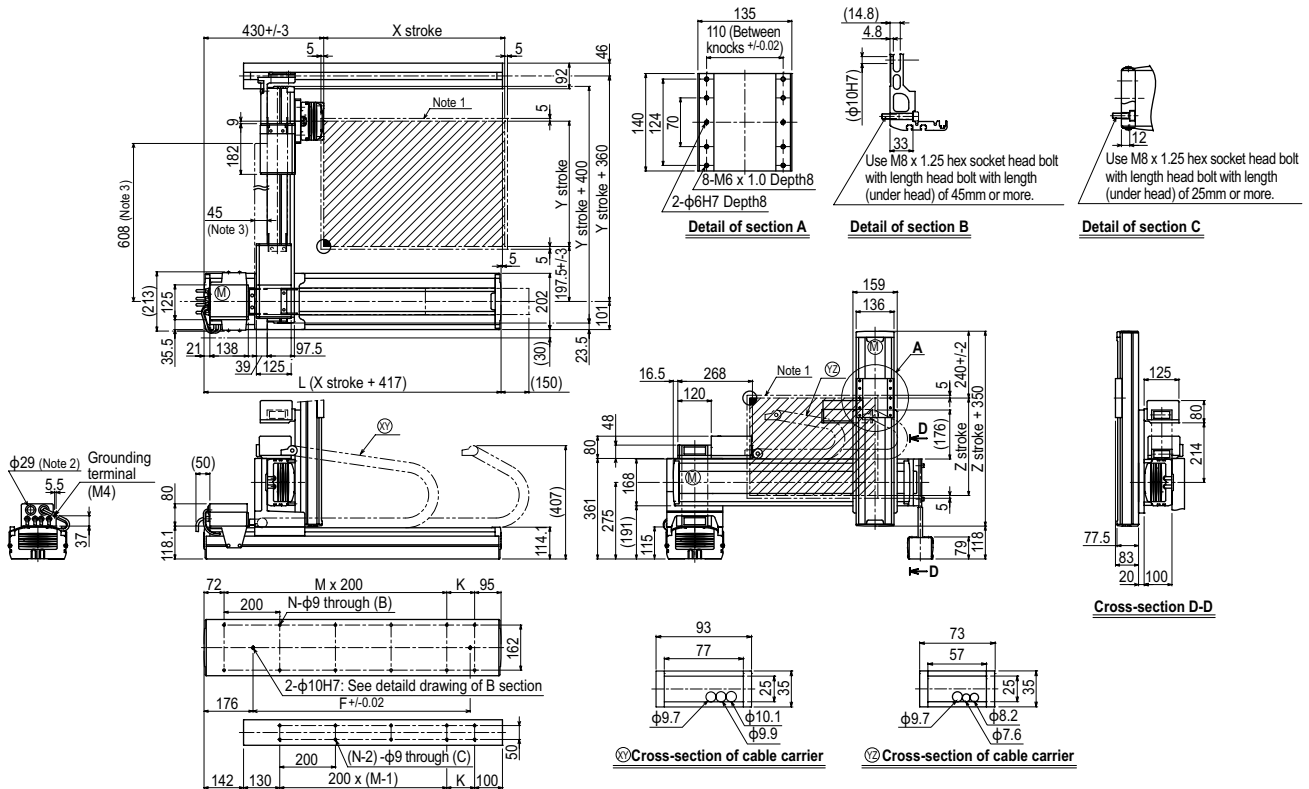

X stroke	250	350	450	550	650	750	850	950	1050	1150	1250
L	667	767	867	967	1067	1167	1267	1367	1467	1567	1667
K	100	200	100	200	100	200	100	200	100	200	100
F	420	420	600	600	780	780	960	960	1140	1320	1320
M	2	2	3	3	4	4	5	5	6	6	7
N	8	8	10	10	12	12	14	14	16	16	18
Y stroke	250	350	450	550	650	750	850	950	1050		
Z stroke	250	350	450	550							
Maximum speed for each stroke (mm/sec) ^{Note 4}	X-axis		1200				960	840	720	600	480
	Y-axis		1200				960	840	720		
	Speed setting		-				80%	70%	60%	50%	40%

Note 1. The moving range when returning to origin and the stop position when stopping by the mechanical stopper.
 Note 2. User cable extraction port.
 Note 3. Dimension of reinforced bracket (To be installed when the Y stroke is 750mm or longer)

Note 4. When the X-axis/Y-axis stroke is longer than 850mm, resonance of the ball screw may occur depending on the operation conditions (critical speed). In this case, reduce the speed setting on the program by referring to the maximum speeds shown in the table at the left.

HXYx 3 axes / ZH

● Gantry type ● Cable carrier ● Z-axis: clamped table / moving base type (200W)

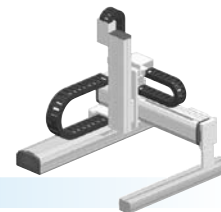

Ordering method

HXYx - C **ZH** **RCX340-3**

Model	Cable	Combination	X-axis stroke	Y-axis stroke	ZR-axis	Z-axis stroke	Cable	Controller / Number of controllable axes	Safety standard	Option A (OP.A)	Option B (OP.B)	Option C (OP.C)	Option D (OP.D)	Option E (OP.E)	Absolute battery
		G1 G2 G3 G4	25 to 125cm	25 to 105cm		25 to 55cm	3L: 3.5m 5L: 5m 10L: 10m	Specify various controller setting items. RCX340 ▶ P.566							

Specification

	X-axis	Y-axis	Z-axis
Axis construction ^{Note 1}	F20	F17	F14H-BK
AC servo motor output (W)	600	400	200
Repeatability ^{Note 2} (mm)	+/-0.01	+/-0.01	+/-0.01
Drive system	Ball screw φ20	Ball screw φ20	Ball screw φ15
Ball screw lead ^{Note 3} (Deceleration ratio) (mm)	20	20	5
Maximum speed ^{Note 4} (mm/sec)	1200	1200	300
Moving range (mm)	250 to 1250	250 to 1050	250 to 550
Robot cable length (m)	Standard: 3.5 Option: 5,10		

Note 1. Use caution that the flame machining (installation holes, tap holes) differs from single-axis robots.
 Note 2. Positioning repeatability in one direction.
 Note 3. Leads not listed in the catalog are also available. Contact us for details.
 Note 4. When the X-axis/Y-axis stroke is longer than 850mm, resonance of the ball screw may occur depending on the operation conditions (critical speed). In this case, reduce the speed setting on the program by referring to the maximum speeds shown in the table below.

Maximum payload (kg)

Y stroke (mm)	Z stroke (mm)
250 to 1050	30

Controller

Controller	Operation method
RCX340	Programming / I/O point trace / Remote command / Operation using RS-232C communication

HXYx 3 axes / ZH G1

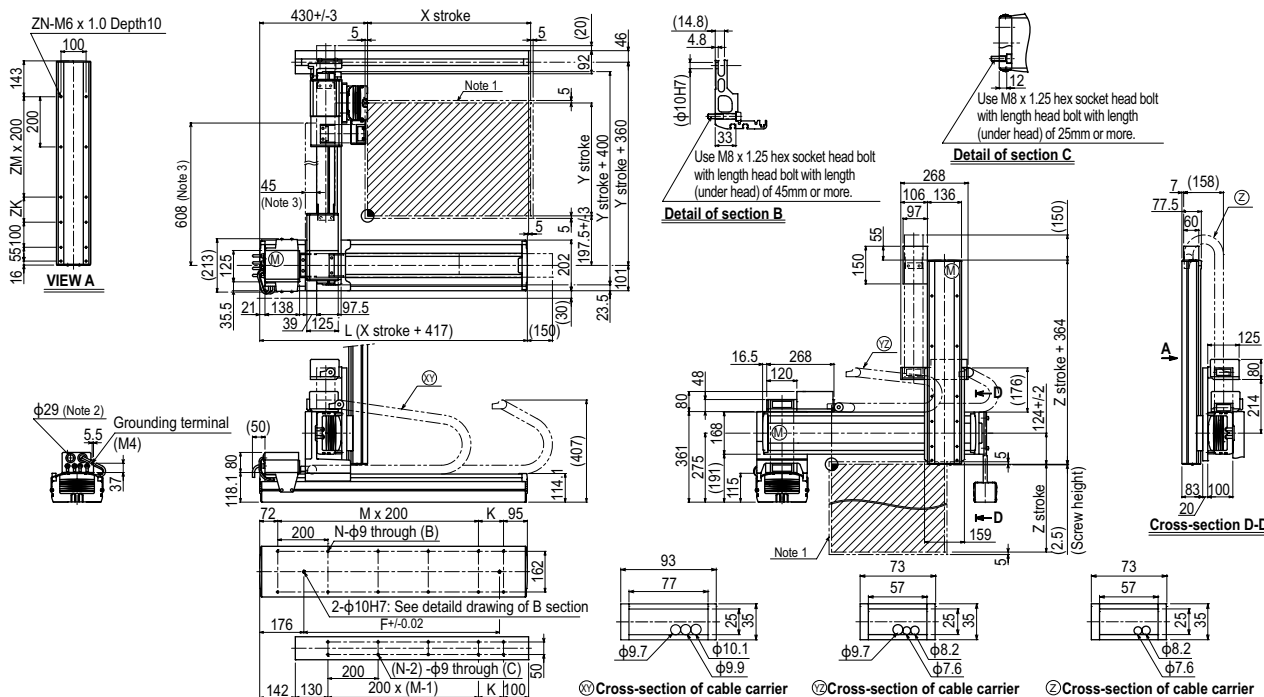

X stroke	250	350	450	550	650	750	850	950	1050	1150	1250
	L	667	767	867	967	1067	1167	1267	1367	1467	1567
K	100	200	100	200	100	200	100	200	100	200	100
F	420	420	600	600	780	780	960	960	1140	1320	1320
M	2	2	3	3	4	4	5	5	6	6	7
N	8	8	10	10	12	12	14	14	16	16	18
Y stroke	250	350	450	550	650	750	850	950	1050		
Z stroke	250	350	450	550							
ZK	100	200	100	200							
ZM	1	1	2	2							
ZN	10	10	12	12							

Note 1. The moving range when returning to origin and the stop position when stopping by the mechanical stopper.
 Note 2. User cable extraction port.
 Note 3. Dimension of reinforced bracket (To be installed when the Y stroke is 750mm or longer)

Maximum speed for each stroke (mm/sec) ^{Note 4}	X-axis	1200					960	840	720	600	480	
	Y-axis	1200					960	840	720			
	Speed setting	-					80%	70%	60%	50%	40%	

Note 4. When the X-axis/Y-axis stroke is longer than 850mm, resonance of the ball screw may occur depending on the operation conditions (critical speed). In this case, reduce the speed setting on the program by referring to the maximum speeds shown in the table at the left.

Articulated robots
YA
Linear conveyor modules
LCM100
Motorless single axis actuator
Robonity
Compact single-axis robots
TRANSEVO
Single-axis robots
FLIP-X
Linear motor single-axis robots
PHASER
Cartesian robots
XY-X
SCARA robots
YK-X
Pick & place robots
YP-X
CLEAN
CONTROLLER INFORMATION
Arm type
Gantry type
Moving arm type
Pole type
XZ type

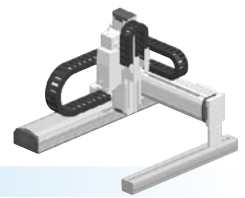

- Gantry type
- Cable carrier
- Z-axis: clamped base / moving table type (200W)+R-axis

Ordering method

HXYx - C - **ZRL** - **RCX340-4**

Model	Cable	Combination	X-axis stroke	Y-axis stroke	ZR-axis	Z-axis stroke	Cable	Controller / Number of controllable axes	Safety standard	Option A (OP.A)	Option B (OP.B)	Option C (OP.C)	Option D (OP.D)	Option E (OP.E)	Absolute battery
		G1 G2 G3 G4	25 to 125cm	25 to 105cm		25 to 55cm	3L: 3.5m 5L: 5m 10L: 10m								

Specify various controller setting items. RCX340 ▶ **P.566**

Specification

	X-axis	Y-axis	Z-axis	R-axis
Axis construction <small>Note 1</small>	F20	F17	F14H-BK	R20
AC servo motor output (W)	600	400	200	200
Repeatability <small>Note 2</small> (XYZ: mm) (R: °)	+/-0.01	+/-0.01	+/-0.01	+/-0.0083
Drive system	Ball screw φ20	Ball screw φ20	Ball screw φ15	Harmonic gear
Ball screw lead <small>Note 3</small> (Deceleration ratio) (mm)	20	20	10	(1/50)
Maximum speed <small>Note 4</small> (XYZ: mm/sec) (R: °/sec)	1200	1200	600	360
Moving range (XYZ: mm) (R: °)	250 to 1250	250 to 1050	250 to 550	360
Robot cable length (m)	Standard: 3.5 Option: 5,10			

- Note 1. Use caution that the flange machining (installation holes, tap holes) differs from single-axis robots.
 Note 2. Positioning repeatability in one direction.
 Note 3. Leads not listed in the catalog are also available. Contact us for details.
 Note 4. When the X-axis/Y-axis stroke is longer than 850mm, resonance of the ball screw may occur depending on the operation conditions (critical speed). In this case, reduce the speed setting on the program by referring to the maximum speeds shown in the table below.

Maximum payload (kg)

Y stroke (mm)	Z stroke (mm)
250 to 1050	250 to 550
	12

Controller

Controller	Operation method
RCX340	Programming / I/O point trace / Remote command / Operation using RS-232C communication

HXYx 4 axes / ZRL (G1)

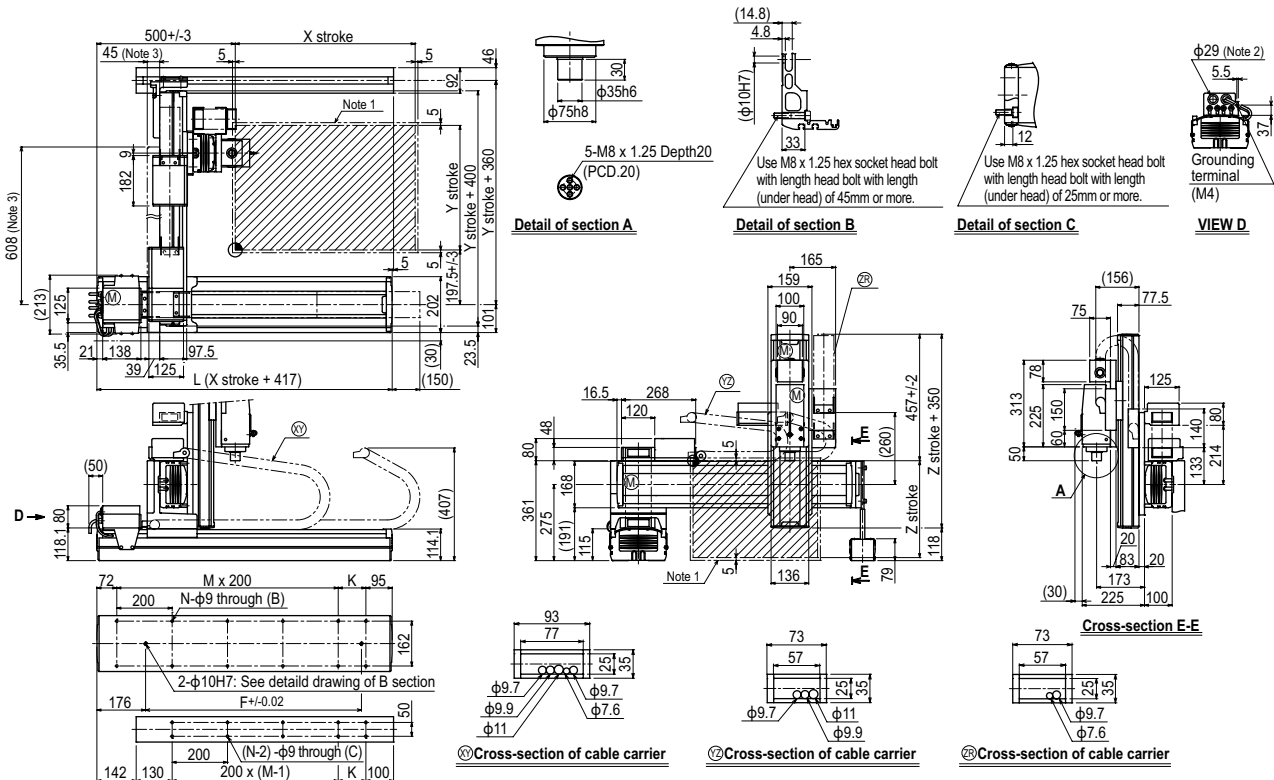

X stroke	250	350	450	550	650	750	850	950	1050	1150	1250	
	L	667	767	867	967	1067	1167	1267	1367	1467	1567	1667
K	100	200	100	200	100	200	100	200	100	200	100	
F	420	420	600	600	780	780	960	960	1140	1320	1320	
M	2	2	3	3	4	4	5	5	6	6	7	
N	8	8	10	10	12	12	14	14	16	16	18	
Y stroke	250	350	450	550	650	750	850	950	1050			
Z stroke	250	350	450	550								
Maximum speed for each stroke (mm/sec) <small>Note 4</small>	X-axis	1200					960	840	720	600	480	
	Y-axis	1200					960	840	720			
Speed setting		-					80%	70%	60%	50%	40%	

- Note 1. The moving range when returning to origin and the stop position when stopping by the mechanical stopper.
 Note 2. User cable extraction port.
 Note 3. Dimension of reinforced bracket (To be installed when the Y stroke is 750mm or longer)

- Note 4. When the X-axis/Y-axis stroke is longer than 850mm, resonance of the ball screw may occur depending on the operation conditions (critical speed). In this case, reduce the speed setting on the program by referring to the maximum speeds shown in the table at the left.

HXYx 4 axes / ZRH

● Gantry type ● Cable carrier ● Z-axis: clamped table / moving base type (200W)+R-axis

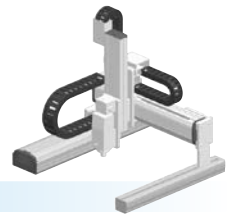

Ordering method

HXYx - C **ZRH** **RCX340-4**

Model	Cable	Combination	X-axis stroke	Y-axis stroke	ZR-axis	Z-axis stroke	Cable	Controller / Number of controllable axes	Safety standard	Option A (OP.A)	Option B (OP.B)	Option C (OP.C)	Option D (OP.D)	Option E (OP.E)	Absolute battery
		G1	25 to 125cm	25 to 105cm		25 to 55cm	3L: 3.5m 5L: 5m 10L: 10m	Specify various controller setting items. RCX340 ▶ P566							

Specification

	X-axis	Y-axis	Z-axis	R-axis
Axis construction ^{Note 1}	F20	F17	F14H	R20
AC servo motor output (W)	600	400	200	200
Repeatability ^{Note 2} (XYZ: mm) (R: °)	+/-0.01	+/-0.01	+/-0.01	+/-0.0083
Drive system	Ball screw ϕ 20	Ball screw ϕ 20	Ball screw ϕ 15	Harmonic gear
Ball screw lead ^{Note 3} (Deceleration ratio) (mm)	20	20	5	(1/50)
Maximum speed ^{Note 4} (XYZ: mm/sec) (R: °/sec)	1200	1200	300	360
Moving range (XYZ: mm) (R: °)	250 to 1250	250 to 1050	250 to 550	360
Robot cable length (m)	Standard: 3.5 Option: 5, 10			

Note 1. Use caution that the flame machining (installation holes, tap holes) differs from single-axis robots.
 Note 2. Positioning repeatability in one direction.
 Note 3. Leads not listed in the catalog are also available. Contact us for details.
 Note 4. When the X-axis/Y-axis stroke is longer than 850mm, resonance of the ball screw may occur depending on the operation conditions (critical speed). In this case, reduce the speed setting on the program by referring to the maximum speeds shown in the table below.

Maximum payload (kg)

Y stroke (mm)	Z stroke (mm)
250 to 1050	20

Controller

Controller	Operation method
RCX340	Programming / I/O point trace / Remote command / Operation using RS-232C communication

HXYx 4 axes / ZRH (G1)

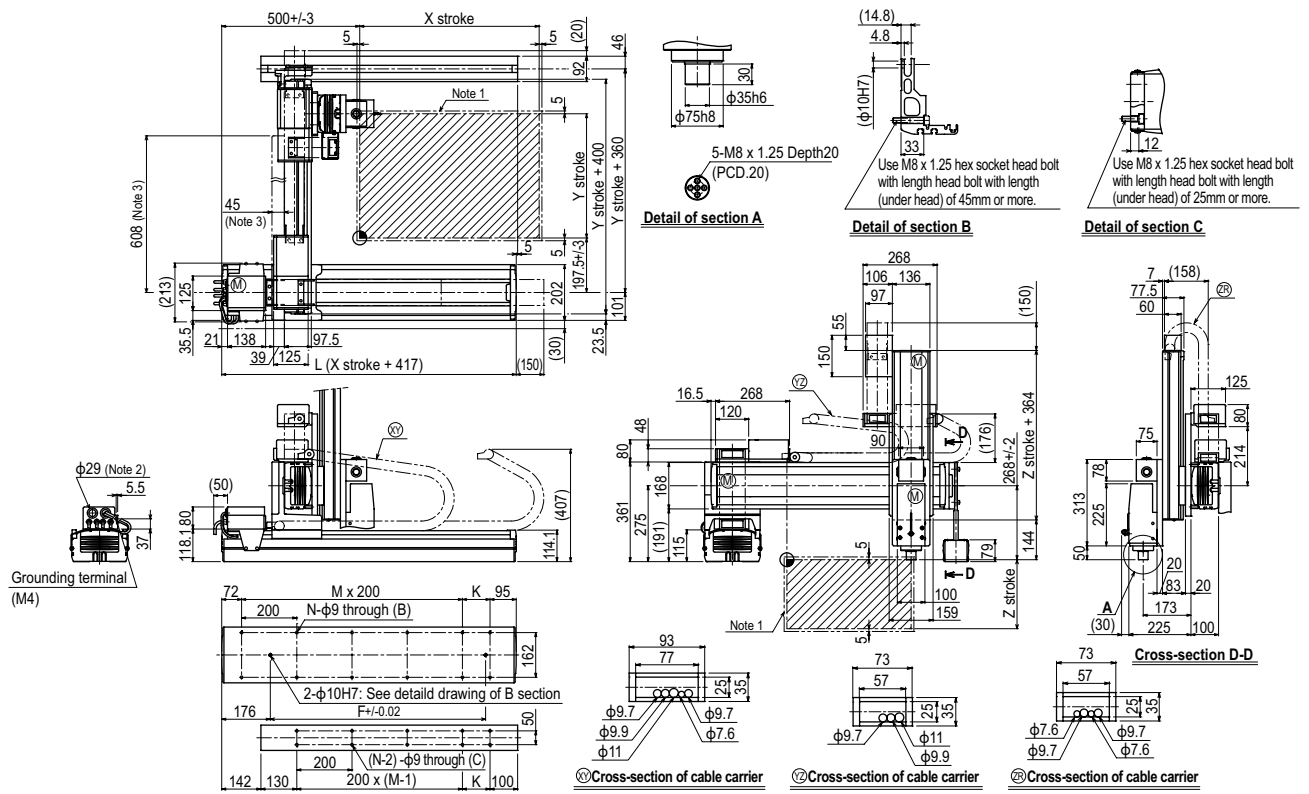

X stroke	250	350	450	550	650	750	850	950	1050	1150	1250
	L	667	767	867	967	1067	1167	1267	1367	1467	1567
K	100	200	100	200	100	200	100	200	100	200	100
F	420	420	600	600	780	780	960	960	1140	1320	1320
M	2	2	3	3	4	4	5	5	6	6	7
N	8	8	10	10	12	12	14	14	16	16	18

Y stroke	250	350	450	550	650	750	850	950	1050
Z stroke	250	350	450	550					

Maximum speed for each stroke (mm/sec) ^{Note 4}	X-axis		1200		960	840	720	600	480
	Y-axis		1200		960	840	720		
	Speed setting		-		80%	70%	60%	50%	40%

Note 1. The moving range when returning to origin and the stop position when stopping by the mechanical stopper.
 Note 2. User cable extraction port.
 Note 3. Dimension of reinforced bracket (To be installed when the Y stroke is 750mm or longer)
 Note 4. When the X-axis/Y-axis stroke is longer than 850mm, resonance of the ball screw may occur depending on the operation conditions (critical speed). In this case, reduce the speed setting on the program by referring to the maximum speeds shown in the table at the left.

Articulated robots
YA
Linear conveyor modules
LCM100
Motor-less single axis actuator
Robonity
Compact single-axis robots
TRANSEVO
Single-axis robots
FLIP-X
Linear motor single-axis robots
PHASER
Cartesian robots
XY-X
SCARA robots
YK-X
Pick & place robots
YP-X
CLEAN
CONTROLLER INFORMATION
Arm type
Gantry type
Moving arm type
Pole type
XZ type

HXYLx 2 axes

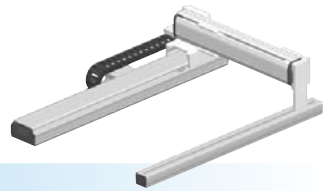

- Gantry type
- Cable carrier

Ordering method

HXYLx - C

Model	Cable	Combination	X-axis stroke	Y-axis stroke	Cable
G1			115 to 205cm	25 to 105cm	3L: 3.5m
G2					5L: 5m
G3					10L: 10m
G4					

RCX320-2 R

Controller / Number of controllable axes Safety standard Regenerative unit Option A (O.P.A) Option B (O.P.B) Vision System Absolute battery

Specify various controller setting items. RCX320 ▶ **P.548**

RCX222HP R

Controller Usable for CE Regenerative unit I/O selection 1 I/O selection 2

Specify various controller setting items. RCX222 ▶ **P.558**

Specification

	X-axis	Y-axis
Axis construction <small>Note 1</small>	F20N	F17
AC servo motor output (W)	400	400
Repeatability <small>Note 2</small> (mm)	+/-0.04	+/-0.01
Drive system	Ball screw φ20	Ball screw φ20
Ball screw lead <small>Note 3</small> (Deceleration ratio) (mm)	20	20
Maximum speed <small>Note 4</small> (mm/sec)	1200	1200
Moving range (mm)	1150 to 2050	250 to 1050
Robot cable length (m)	Standard: 3.5 Option: 5,10	

Note 1. Use caution that the flame machining (installation holes, tap holes) differs from single-axis robots.
 Note 2. Positioning repeatability in one direction.
 Note 3. Leads not listed in the catalog are also available. Contact us for details.
 Note 4. When the Y-axis stroke is longer than 850mm, resonance of the ball screw may occur depending on the operation conditions (critical speed). In this case, reduce the speed setting on the program by referring to the maximum speeds shown in the table below.

Maximum payload (kg)

Y stroke (mm)	XY 2 axes
250 to 1050	50

Controller

Controller	Operation method
RCX320-R	Programming / I/O point trace / Remote command / Operation using RS-232C communication
RCX222HP-R	

HXYLx 2 axes G1

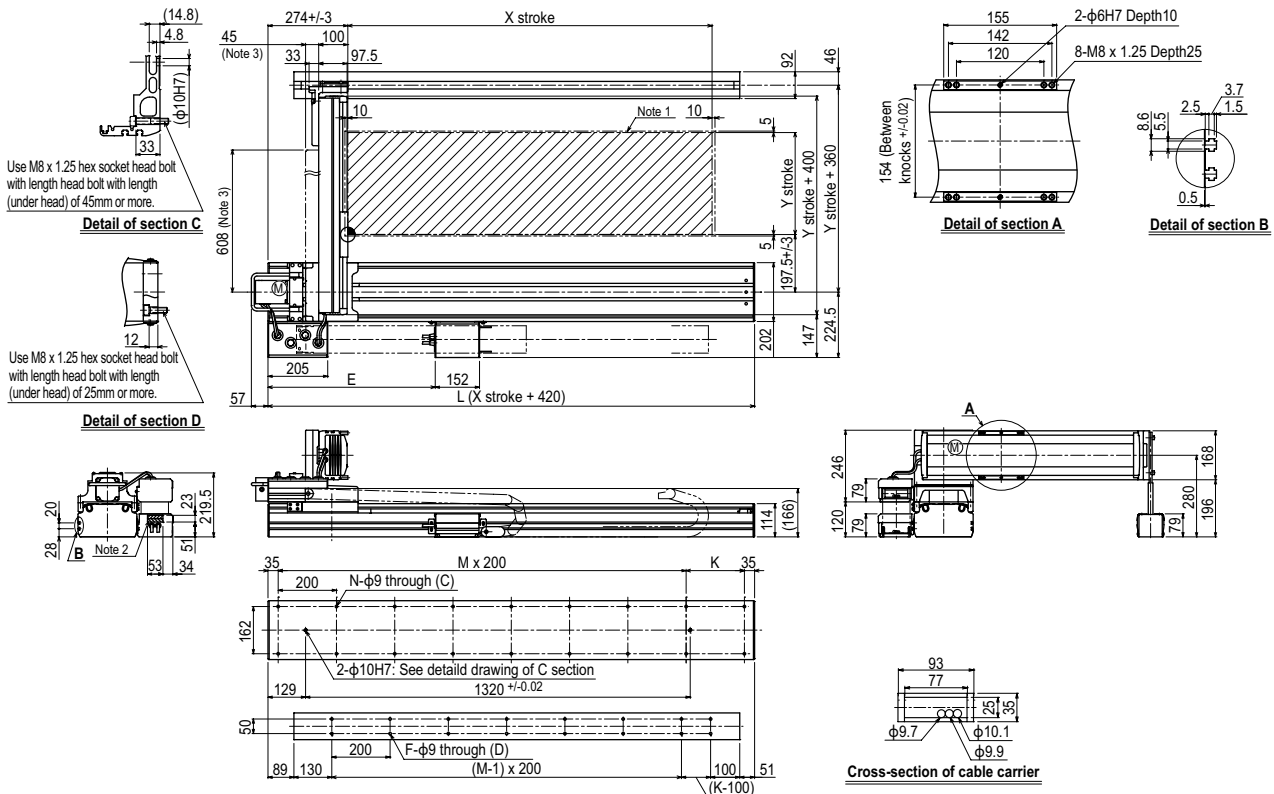

X stroke	1150	1250	1350	1450	1550	1650	1750	1850	1950	2050
L	1570	1670	1770	1870	1970	2070	2170	2270	2370	2470
E	528	574	620	666	712	758	804	850	896	942
K	100	200	100	200	100	200	100	200	100	200
M	7	7	8	8	9	9	10	10	11	11
N	18	18	20	20	22	22	24	24	26	26
F	14	16	16	18	18	20	20	22	22	24
Y stroke	250	350	450	550	650	750	850	950	1050	
Maximum speed for each stroke (mm/sec) <small>Note 4</small>	Y-axis		1200				960	840	720	
Speed setting			-				80%	70%	60%	

Note 1. The moving range when returning to origin and the stop position when stopping by the mechanical stopper.
 Note 2. User cable extraction port.
 Note 3. Dimension of reinforced bracket (To be installed when the Y stroke is 750mm or longer)
 Note 4. When the Y-axis stroke is longer than 850mm, resonance of the ball screw may occur depending on the operation conditions (critical speed). In this case, reduce the speed setting on the program by referring to the maximum speeds shown in the table at the left.

HXYLx 2 axes **G2**

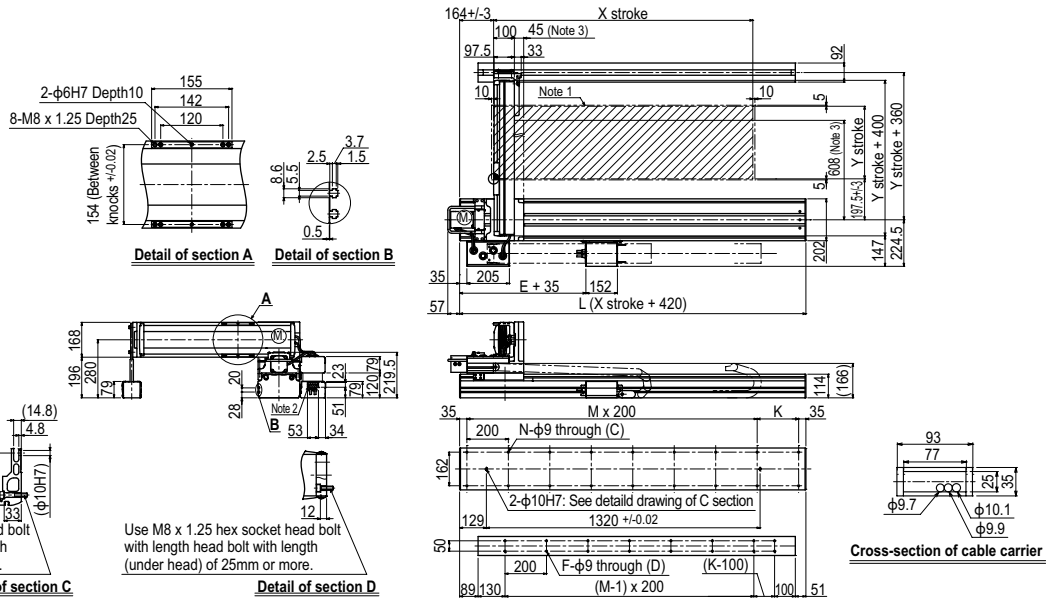

HXYLx 2 axes **G3**

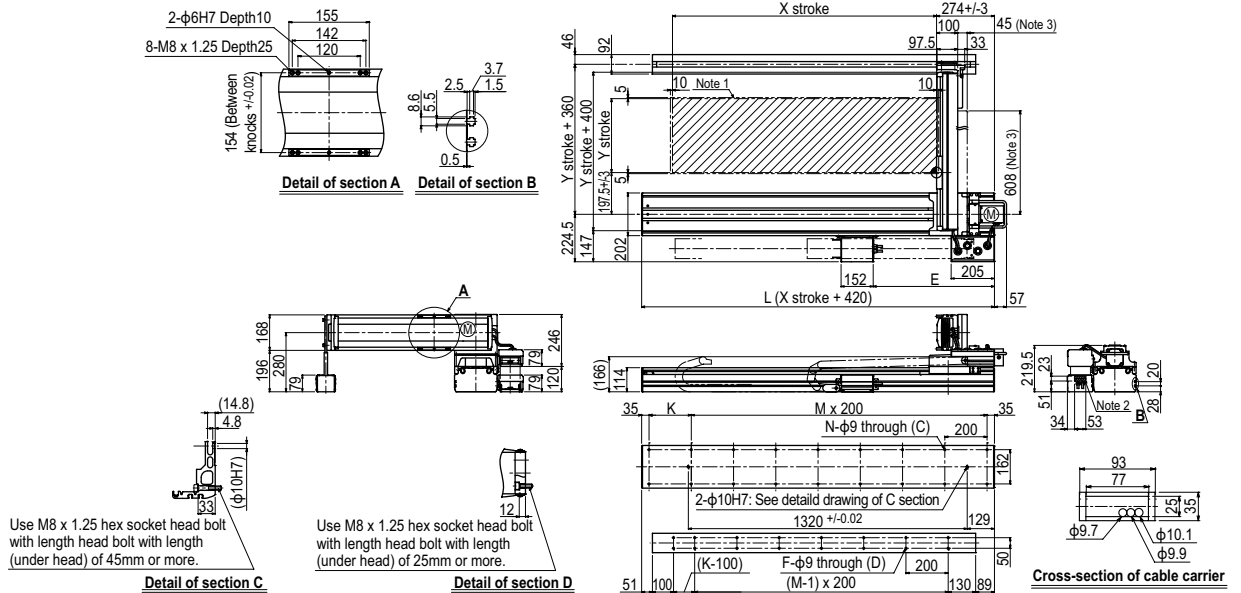

HXYLx 2 axes **G4**

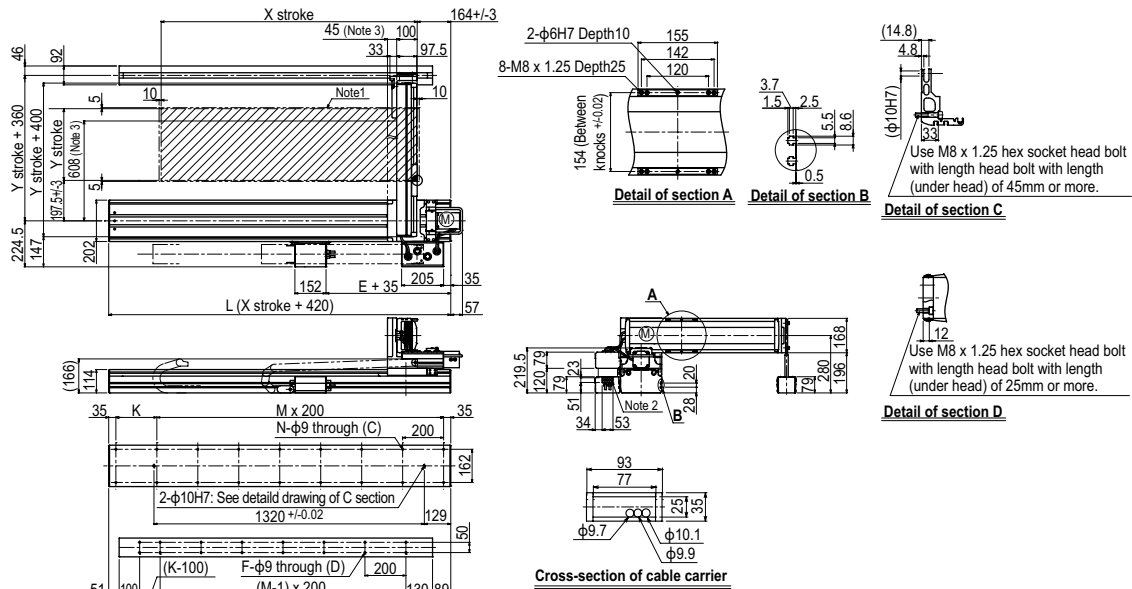

SXYx 2 axes

● Moving arm type ● Whipover



Ordering method

SXYx - S

Model	Cable	Combination	X-axis stroke ^{Note 3}	Y-axis stroke ^{Note 1}	Cable
M1	M3		15 to 85cm	15 to 35cm	3L: 3.5m 5L: 5m 10L: 10m

RCX320-2

Controller / Number of controllable axes	Safety standard	Option A (O.P.A)	Option B (O.P.B)	Vision System	Absolute battery

Specify various controller setting items. RCX320 ▶ **P.548**

RCX222

Controller	Usable for CE	I/O selection 1	I/O selection 2

Specify various controller setting items. RCX222 ▶ **P.558**

Note 1. The total of the X and Y strokes should be 1000mm or less.

Specification

	X-axis	Y-axis
Axis construction ^{Note 1}	F14H	F14
AC servo motor output (W)	200	100
Repeatability ^{Note 2} (mm)	+/-0.01	+/-0.01
Drive system	Ball screw φ15	Ball screw φ15
Ball screw lead ^{Note 3} (Deceleration ratio) (mm)	20	20
Maximum speed ^{Note 4} (mm/sec)	1200	1200
Moving range (mm)	150 to 850	150 to 350
Robot cable length (m)	Standard: 3.5 Option: 5,10	

Note 1. Use caution that the flange machining (installation holes, tap holes) differs from single-axis robots.
 Note 2. Positioning repeatability in one direction.
 Note 3. Leads not listed in the catalog are also available. Contact us for details.
 Note 4. When the X-axis stroke is longer than 750mm, resonance of the ball screw may occur depending on the operation conditions (critical speed). In this case, reduce the speed setting on the program by referring to the maximum speeds shown in the table below.

Maximum payload (kg)

Y stroke (mm)	XY 2 axes
150	15
250	14
350	13

Controller

Controller	Operation method
RCX320	Programming / I/O point trace / Remote command / Operation using RS-232C communication
RCX222	

SXYx 2 axes M1

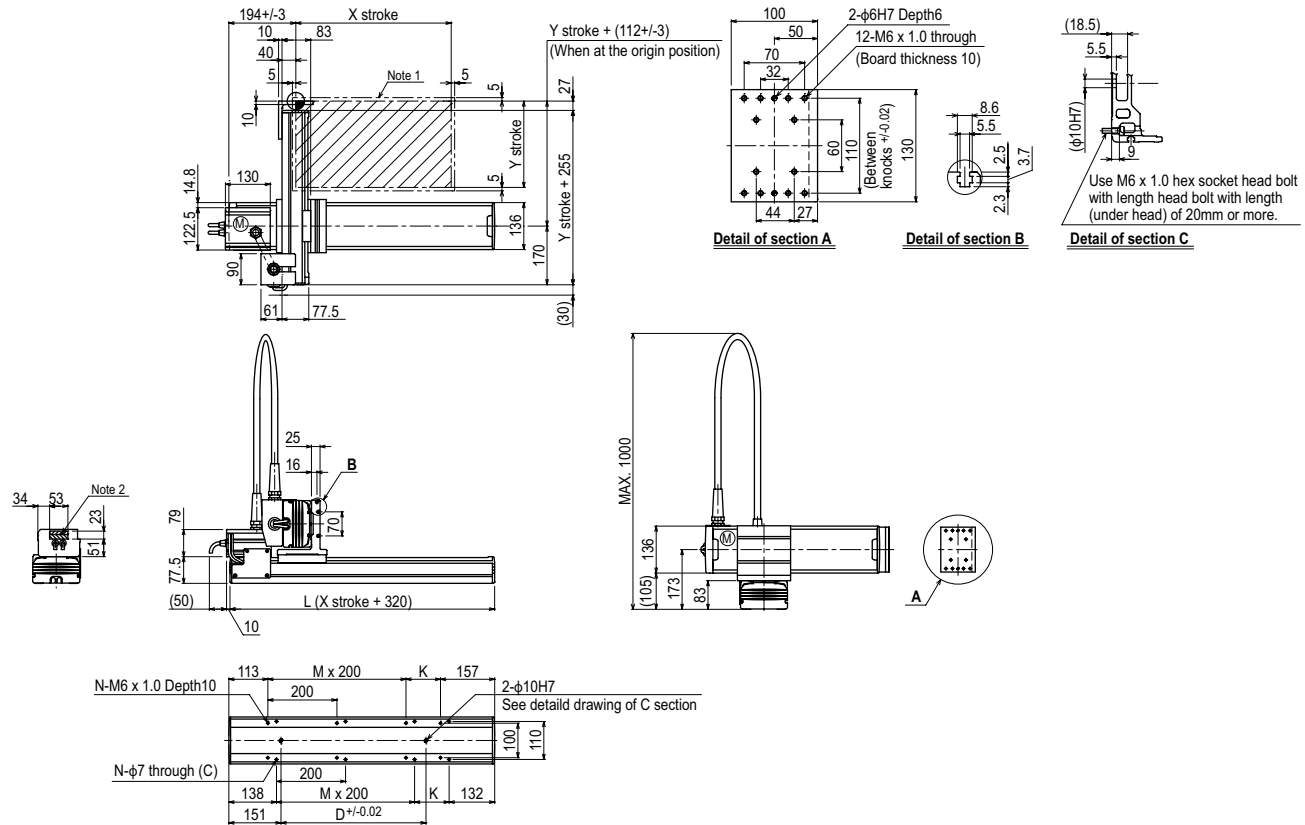

X stroke ^{Note 3}	150	250	350	450	550	650	750	850
L	470	570	670	770	870	970	1070	1170
K	200	100	200	100	200	100	200	100
D	240	240	420	420	600	600	780	960
M	0	1	1	2	2	3	3	4
N	4	6	6	8	8	10	10	12
Y stroke ^{Note 3}	150	250	350					
Maximum speed for each stroke (mm/sec) ^{Note 4}	X-axis		1200		960		780	
Speed setting			-		80%		65%	

Note 1. The moving range when returning to origin and the stop position when stopping by the mechanical stopper.
 Note 2. The shaded position indicates a user cable extraction port.

Note 3. The total of the X and Y strokes should be 1000mm or less.
 Note 4. When the X-axis stroke is longer than 750mm, resonance of the ball screw may occur depending on the operation conditions (critical speed). In this case, reduce the speed setting on the program by referring to the maximum speeds shown in the table at the left.

SXYx 2 axes M3

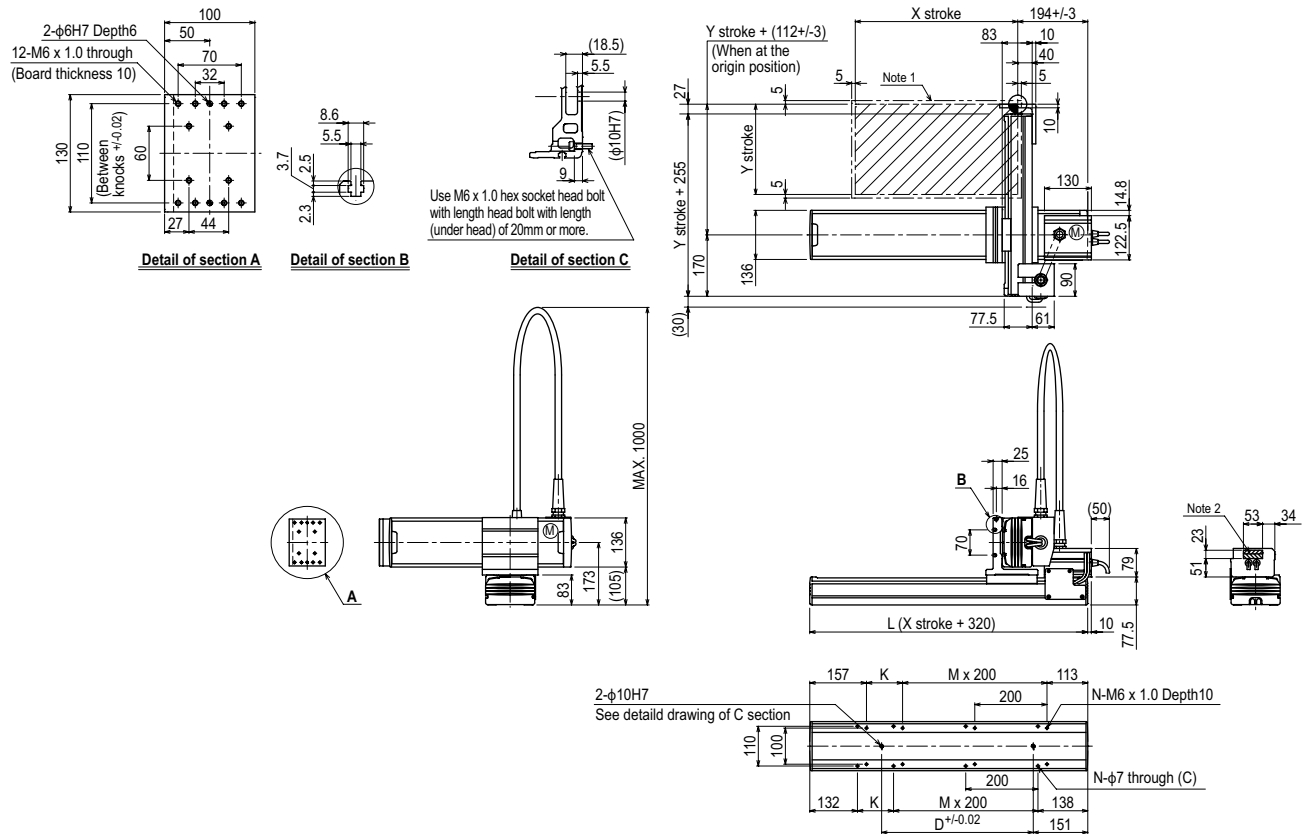

X stroke ^{Note 3}	150	250	350	450	550	650	750	850
L	470	570	670	770	870	970	1070	1170
K	200	100	200	100	200	100	200	100
D	240	240	420	420	600	600	780	960
M	0	1	1	2	2	3	3	4
N	4	6	6	8	8	10	10	12
Y stroke ^{Note 3}	150	250	350					
Maximum speed for each stroke (mm/sec) ^{Note 4}	X-axis		1200			960		780
Speed setting			-			80%		65%

Note 1. The moving range when returning to origin and the stop position when stopping by the mechanical stopper.

Note 2. The shaded position indicates an user cable extraction port.

Note 3. The total of the X and Y strokes should be 1000mm or less.

Note 4. When the X-axis stroke is longer than 750mm, resonance of the ball screw may occur depending on the operation conditions (critical speed). In this case, reduce the speed setting on the program by referring to the maximum speeds shown in the table at the left.

SXYx 3 axes / ZF

● Moving arm type ● Whipover ● Z-axis: clamped base / moving table type (100W)

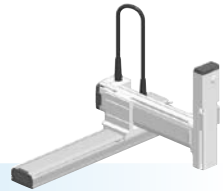

Ordering method

SXYx - S [] [] [] **ZF** [] [] **RCX340-3** [] [] [] [] [] [] [] [] [] [] []

Model	Cable	Combination	X-axis stroke Note 1	Y-axis stroke Note 1	ZR-axis	Z-axis stroke	Cable	Controller / Number of controllable axes	Safety standard	Option A (OP.A)	Option B (OP.B)	Option C (OP.C)	Option D (OP.D)	Option E (OP.E)	Absolute battery
		M1 M3	15 to 85cm	15 to 35cm		15 to 35cm	3L: 3.5m 5L: 5m 10L: 10m								

Specify various controller setting items. RCX340 ▶ **P.566**

Note 1. The total of the X and Y strokes should be 1000mm or less.

Specification

	X-axis	Y-axis	Z-axis
Axis construction Note 1	F14H	F14	F10-BK
AC servo motor output (W)	200	100	100
Repeatability Note 2 (mm)	+/-0.01	+/-0.01	+/-0.01
Drive system	Ball screw $\phi 15$	Ball screw $\phi 15$	Ball screw $\phi 15$
Ball screw lead Note 3 (Deceleration ratio) (mm)	20	20	10
Maximum speed Note 4 (mm/sec)	1200	1200	600
Moving range (mm)	150 to 850	150 to 350	150 to 350
Robot cable length (m)	Standard: 3.5 Option: 5,10		

Note 1. Use caution that the flame machining (installation holes, tap holes) differs from single-axis robots.
 Note 2. Positioning repeatability in one direction.
 Note 3. Leads not listed in the catalog are also available. Contact us for details.
 Note 4. When the X-axis stroke is longer than 750mm, resonance of the ball screw may occur depending on the operation conditions (critical speed). In this case, reduce the speed setting on the program by referring to the maximum speeds shown in the table below.

Maximum payload (kg)

Y stroke (mm)	Z stroke (mm)		
	150	250	350
150	9	8	7
250	8	7	6
350	7	6	5

Controller

Controller	Operation method
RCX340	Programming / I/O point trace / Remote command / Operation using RS-232C communication

SXYx 3 axes / ZF M1

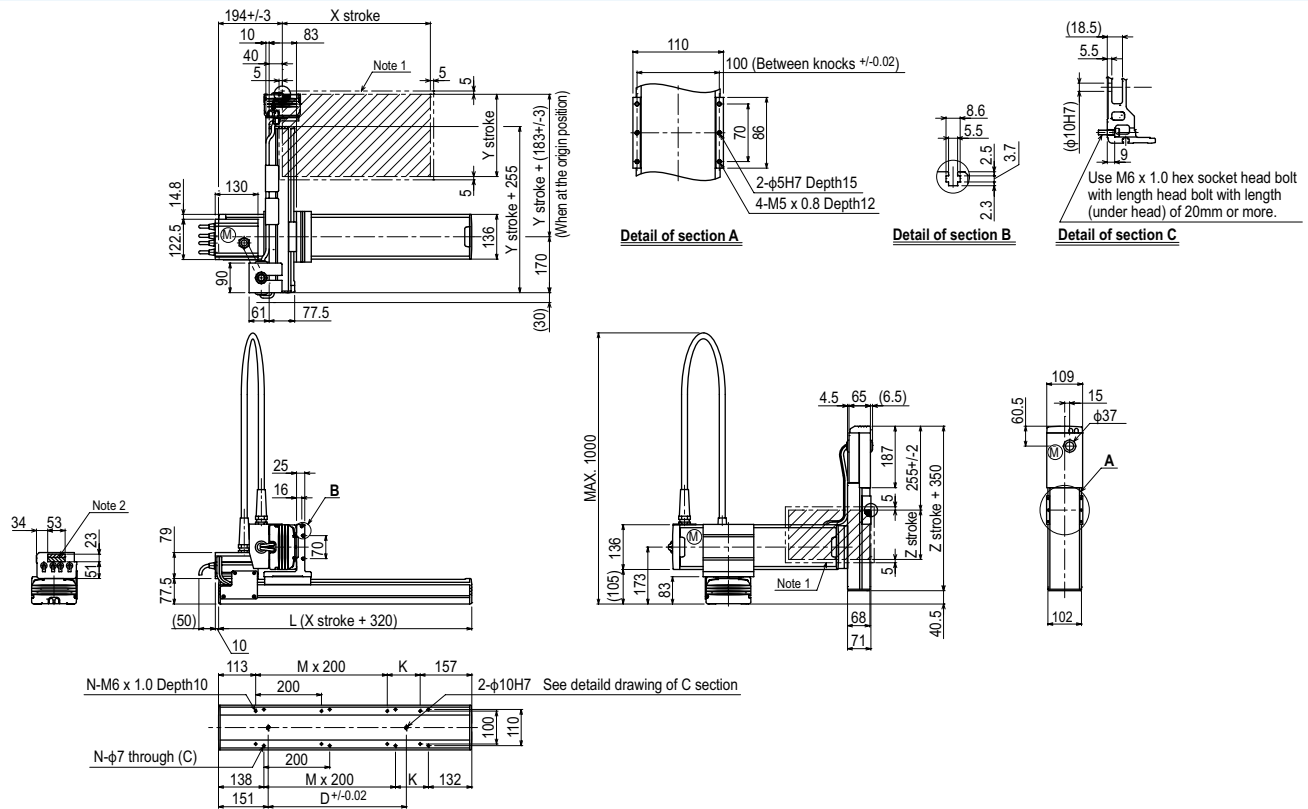

X stroke Note 3	150	250	350	450	550	650	750	850	
	L	470	570	670	770	870	970	1070	1170
K	200	100	200	100	200	100	200	100	
D	240	240	420	420	600	600	780	960	
M	0	1	1	2	2	3	3	4	
N	4	6	6	8	8	10	10	12	
Y stroke Note 3		150	250	350					
Z stroke		150	250	350					
Maximum speed for each stroke (mm/sec) Note 4	X-axis	1200			960			780	
	Speed setting	-			80%			65%	

Note 1. The moving range when returning to origin and the stop position when stopping by the mechanical stopper.
 Note 2. The shaded position indicates a user cable extraction port.

Note 3. The total of the X and Y strokes should be 1000mm or less.
 Note 4. When the X-axis stroke is longer than 750mm, resonance of the ball screw may occur depending on the operation conditions (critical speed). In this case, reduce the speed setting on the program by referring to the maximum speeds shown in the table at the left.

SXYx 3 axes / ZFL20

Moving arm type
Whipover
Z-axis: clamped base / moving table type (200W)

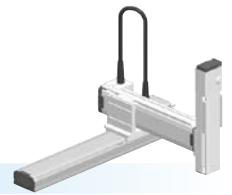

Ordering method

SXYx - S [] [] [] **ZFL20** [] [] **RCX340-3** [] [] [] [] [] [] [] []

Model	Cable	Combination M1 M3	X-axis stroke ^{Note 1} 15 to 85cm	Y-axis stroke ^{Note 1} 15 to 35cm	ZR-axis	Z-axis stroke 15 to 35cm	Cable 3L: 3.5m 5L: 5m 10L: 10m	Controller / Number of controllable axes	Safety standard	Option A (OP.A)	Option B (OP.B)	Option C (OP.C)	Option D (OP.D)	Option E (OP.E)	Absolute battery
--------------	--------------	--------------------------------	--	--	----------------	------------------------------------	--	---	------------------------	------------------------	------------------------	------------------------	------------------------	------------------------	-------------------------

Specify various controller setting items. RCX340 ▶ P.566

Note 1. The total of the X and Y strokes should be 1000mm or less.

Specification

	X-axis	Y-axis	Z-axis
Axis construction ^{Note 1}	F14H	F14	F10H-BK
AC servo motor output (W)	200	100	200
Repeatability ^{Note 2} (mm)	+/-0.01	+/-0.01	+/-0.01
Drive system	Ball screw φ15	Ball screw φ15	Ball screw φ15
Ball screw lead ^{Note 3} (Deceleration ratio) (mm)	20	20	20
Maximum speed ^{Note 4} (mm/sec)	1200	1200	1200
Moving range (mm)	150 to 850	150 to 350	150 to 350
Robot cable length (m)	Standard: 3.5 Option: 5,10		

Note 1. Use caution that the flame machining (installation holes, tap holes) differs from single-axis robots.
 Note 2. Positioning repeatability in one direction.
 Note 3. Leads not listed in the catalog are also available. Contact us for details.
 Note 4. When the X-axis stroke is longer than 750mm, resonance of the ball screw may occur depending on the operation conditions (critical speed). In this case, reduce the speed setting on the program by referring to the maximum speeds shown in the table below.

Maximum payload (kg)

Y stroke (mm)	Z stroke (mm)		
	150	250	350
150	8	8	7
250	8	7	6
350	7	6	5

Controller

Controller	Operation method
RCX340	Programming / I/O point trace / Remote command / Operation using RS-232C communication

SXYx 3 axes / ZFL20 M1

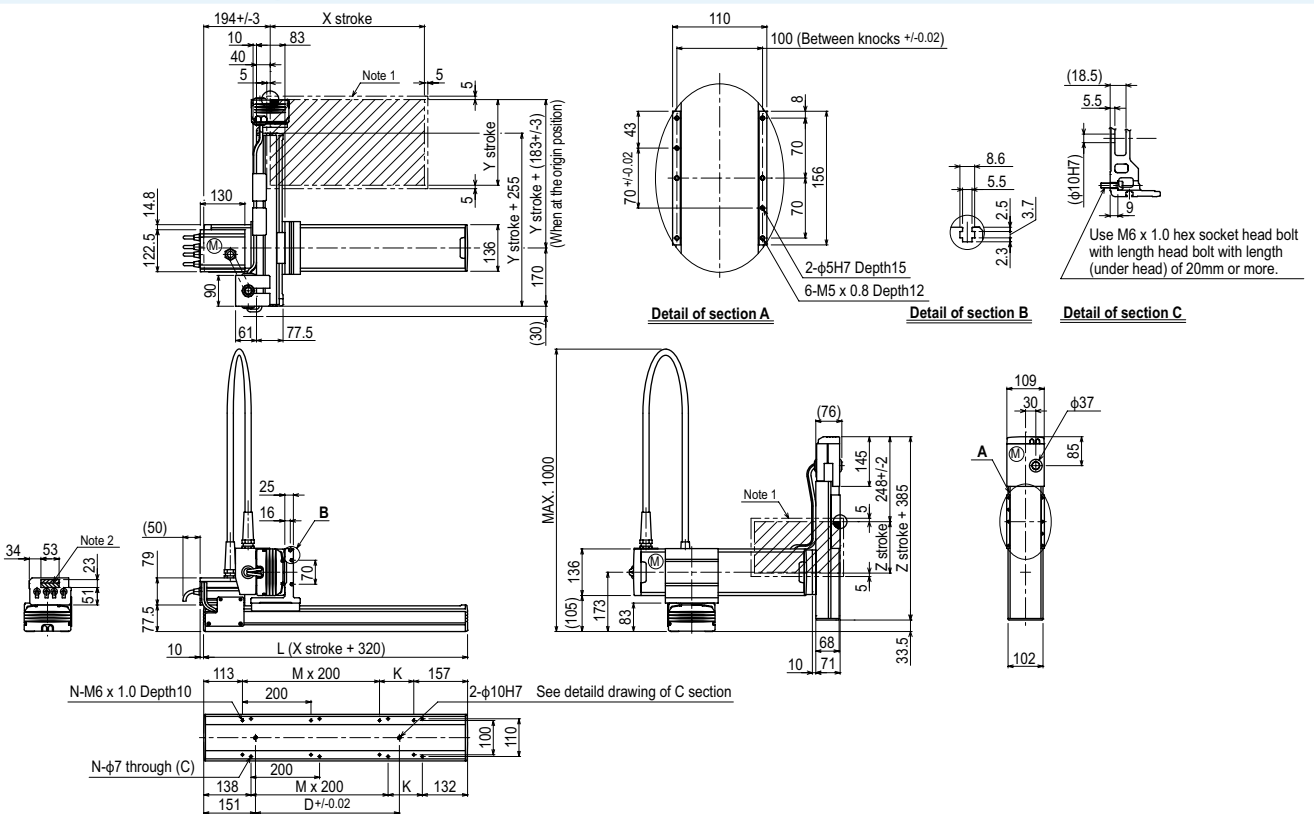

X stroke	150	250	350	450	550	650	750	850
	L	470	570	670	770	870	970	1070
A	200	100	200	100	200	100	200	100
D	240	240	420	420	600	600	780	960
M	0	1	1	2	2	3	3	4
N	4	6	6	8	8	10	10	12

Y stroke	150	250	350
Z stroke	150	250	350

Maximum speed for each stroke (mm/sec)	X-axis	1200	960	780
	Speed setting		-	80%

Note 1. The moving range when returning to origin and the stop position when stopping by the mechanical stopper.
 Note 2. The shaded position indicates a user cable extraction port.

Note 3. The total of the X and Y strokes should be 1000mm or less.
 Note 4. When the X-axis stroke is longer than 750mm, resonance of the ball screw may occur depending on the operation conditions (critical speed). In this case, reduce the speed setting on the program by referring to the maximum speeds shown in the table at the left.

SXYx 3 axes / ZFH

- Moving arm type
- Whipover
- Z-axis: clamped table / moving base type (200W)

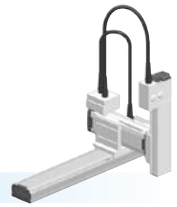

Ordering method

SXYx-S [] [] [] **ZFH** [] [] **RCX340-3** [] [] [] [] [] [] [] [] [] [] [] []

Model	Cable	Combination	X-axis stroke ^{Note 1}	Y-axis stroke ^{Note 1}	ZR-axis	Z-axis stroke	Cable	Controller / Number of controllable axes	Safety standard	Option A (OP.A)	Option B (OP.B)	Option C (OP.C)	Option D (OP.D)	Option E (OP.E)	Absolute battery
		M1 M3	15 to 85cm	15 to 35cm		15 to 35cm	3L: 3.5m 5L: 5m 10L: 10m								

Specify various controller setting items. RCX340 ▶ **P.566**

Note 1. The total of the X and Y strokes should be 1000mm or less.

Specification

	X-axis	Y-axis	Z-axis
Axis construction ^{Note 1}	F14H	F14	F10H-BK
AC servo motor output (W)	200	100	200
Repeatability ^{Note 2} (mm)	+/-0.01	+/-0.01	+/-0.01
Drive system	Ball screw φ15	Ball screw φ15	Ball screw φ15
Ball screw lead ^{Note 3} (Deceleration ratio) (mm)	20	20	10
Maximum speed ^{Note 4} (mm/sec) (°/sec)	1200	1200	600
Moving range (mm)	150 to 850	150 to 350	150 to 350
Robot cable length (m)	Standard: 3.5 Option: 5,10		

- Note 1. Use caution that the flange machining (installation holes, tap holes) differs from single-axis robots.
 Note 2. Positioning repeatability in one direction.
 Note 3. Leads not listed in the catalog are also available. Contact us for details.
 Note 4. When the X-axis stroke is longer than 750mm, resonance of the ball screw may occur depending on the operation conditions (critical speed). In this case, reduce the speed setting on the program by referring to the maximum speeds shown in the table below.

Maximum payload (kg)

Y stroke (mm)	Z stroke (mm)		
	150	250	350
150	9	8	7
250	8	7	6
350	7	6	5

Controller

Controller	Operation method
RCX340	Programming / I/O point trace / Remote command / Operation using RS-232C communication

SXYx 3 axes / ZFH (M1)

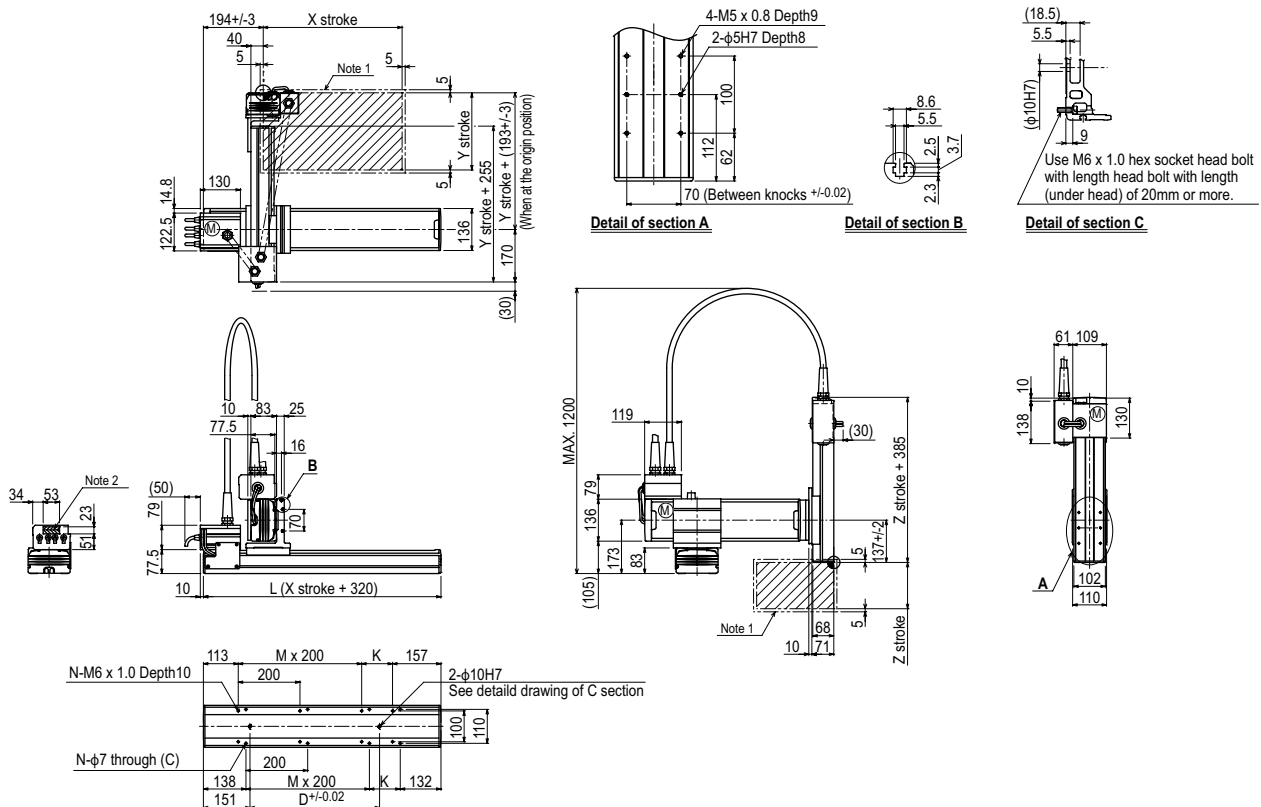

X stroke ^{Note 3}	150	250	350	450	550	650	750	850
	L	470	570	670	770	870	970	1070
K	200	100	200	100	200	100	200	100
D	240	240	420	420	600	600	780	960
M	0	1	1	2	2	3	3	4
N	4	6	6	8	8	10	10	12
Y stroke ^{Note 3}	150 250 350							
Z stroke	150 250 350							
Maximum speed for each stroke (mm/sec) ^{Note 4}	X-axis		1200		960		780	
	Speed setting		-		80%		65%	

- Note 1. The moving range when returning to origin and the stop position when stopping by the mechanical stopper.
 Note 2. The shaded position indicates a user cable extraction port.
 Note 3. The total of the X and Y strokes should be 1000mm or less.
 Note 4. When the X-axis stroke is longer than 750mm, resonance of the ball screw may occur depending on the operation conditions (critical speed). In this case, reduce the speed setting on the program by referring to the maximum speeds shown in the table at the left.

SXYx 3 axes / ZS

- Moving arm type
- Whipover
- Z-axis shaft vertical type

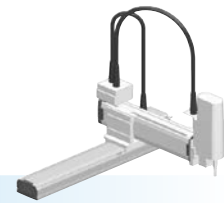

Ordering method

SXYx - S [] [] [] [] **15** [] **RCX340-3** [] [] [] [] [] [] [] [] [] [] [] []

Model	Cable	Combination	X-axis stroke ^{Note 1}	Y-axis stroke ^{Note 1}	ZR-axis	Z-axis stroke	Cable	Controller / Number of controllable axes	Safety standard	Option A (OP.A)	Option B (OP.B)	Option C (OP.C)	Option D (OP.D)	Option E (OP.E)	Absolute battery
		M1 M3	15 to 85cm	15 to 35cm	ZS12 ZS6		3L: 3.5m 5L: 5m 10L: 10m								

Specify various controller setting items. RCX340 ▶ **P566**

Note 1. The total of the X and Y strokes should be 1000mm or less.

Specification

	X-axis	Y-axis	Z-axis: ZS12	Z-axis: ZS6
Axis construction ^{Note 1}	F14H	F14	-	
AC servo motor output (W)	200	100	60	
Repeatability ^{Note 2} (mm)	+/-0.01	+/-0.01	+/-0.02	
Drive system	Ball screw φ15	Ball screw φ15	Ball screw φ12	
Ball screw lead ^{Note 3} (Deceleration ratio) (mm)	20	20	12	6
Maximum speed ^{Note 4} (mm/sec)	1200	1200	1000	500
Moving range (mm)	150 to 850	150 to 350	150	
Robot cable length (m)	Standard: 3.5 Option: 5,10			

Note 1. Use caution that the flange machining (installation holes, tap holes) differs from single-axis robots'.

Note 2. Positioning repeatability in one direction.

Note 3. Leads not listed in the catalog are also available. Contact us for details.

Note 4. When the X-axis stroke is longer than 750mm, resonance of the ball screw may occur depending on the operation conditions (critical speed). In this case, reduce the speed setting on the program by referring to the maximum speeds shown in the table below.

Maximum payload (kg)

Y stroke (mm)	ZS12	ZS6
150 to 350	3	5

Controller

Controller	Operation method
RCX340	Programming / I/O point trace / Remote command / Operation using RS-232C communication

SXYx 3 axes / ZS M1

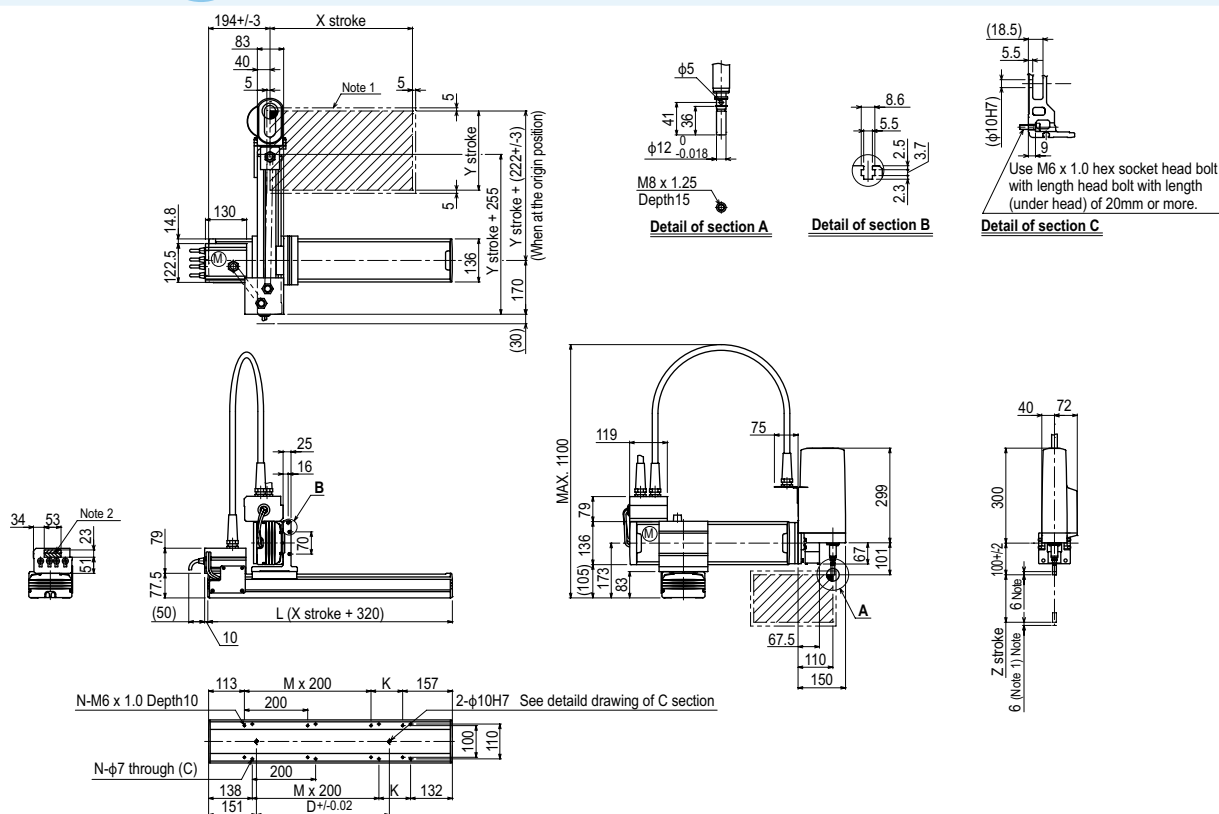

X stroke ^{Note 3}	150	250	350	450	550	650	750	850
	L	470	570	670	770	870	970	1070
K	200	100	200	100	200	100	200	100
D	240	240	420	420	600	600	780	960
M	0	1	1	2	2	3	3	4
N	4	6	6	8	8	10	10	12
Y stroke ^{Note 3}	150	250	350					
Z stroke	150							
Maximum speed for each stroke (mm/sec) ^{Note 4}	X-axis	1200			960		780	
Speed setting		-			80%		65%	

Note 1. The moving range when returning to origin and the stop position when stopping by the mechanical stopper.

Note 2. The shaded position indicates a user cable extraction port.

Note 3. The total of the X and Y strokes should be 1000mm or less.

Note 4. When the X-axis stroke is longer than 750mm, resonance of the ball screw may occur depending on the operation conditions (critical speed). In this case, reduce the speed setting on the program by referring to the maximum speeds shown in the table at the left.

- Articulated robots YA
- Linear conveyor modules LCM100
- Motor-less single-axis robot Robonity
- Compact single-axis robots TRANSEVO
- Single-axis robots FLIP-X
- Linear motor single-axis robots PHASER
- Cartesian robots XY-X
- SCARA robots YK-X
- Pick & place robots YP-X
- CLEAN
- CONTROLLER INFORMATION
- Arm type
- Gantry type
- Moving arm type
- Pole type
- XZ type

MXYx 2 axes

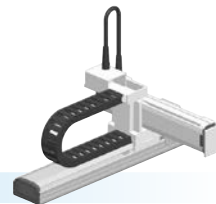

● Moving arm type ● Cable carrier

Ordering method

MXYx - C

Model	Cable	Combination	X-axis stroke	Y-axis stroke	Cable
M1	M1		25 to 125cm	15 to 55cm	3L: 3.5m 5L: 5m 10L: 10m
M3	M3				

RCX320-2 **R**

Controller / Number of controllable axes	Safety standard	Regenerative unit	Option A (OP.A)	Option B (OP.B)	Vision System	Absolute battery
--	-----------------	-------------------	-----------------	-----------------	---------------	------------------

Specify various controller setting items. RCX320 ▶ **P.548**

RCX222 **R**

Controller	Usable for CE	Regenerative unit	I/O selection 1	I/O selection 2
------------	---------------	-------------------	-----------------	-----------------

Specify various controller setting items. RCX222 ▶ **P.558**

Specification

	X-axis	Y-axis
Axis construction <small>Note 1</small>	F17	F14H
AC servo motor output (W)	400	200
Repeatability <small>Note 2</small> (mm)	+/-0.01	+/-0.01
Drive system	Ball screw φ20	Ball screw φ15
Ball screw lead <small>Note 3</small> (Deceleration ratio) (mm)	20	20
Maximum speed <small>Note 4</small> (mm/sec)	1200	1200
Moving range (mm)	250 to 1250	150 to 550
Robot cable length (m)	Standard: 3.5 Option: 5,10	

Note 1. Use caution that the flame machining (installation holes, tap holes) differs from single-axis robots.
 Note 2. Positioning repeatability in one direction.
 Note 3. Leads not listed in the catalog are also available. Contact us for details.
 Note 4. When the X-axis stroke is longer than 850mm, resonance of the ball screw may occur depending on the operation conditions (critical speed). In this case, reduce the speed setting on the program by referring to the maximum speeds shown in the table below.

Maximum payload (kg)

Y stroke (mm)	XY 2 axes
150 to 550	20

Controller

Controller	Operation method
RCX320-R	Programming / I/O point trace / Remote command / Operation using RS-232C communication
RCX222-R	

MXYx 2 axes M1

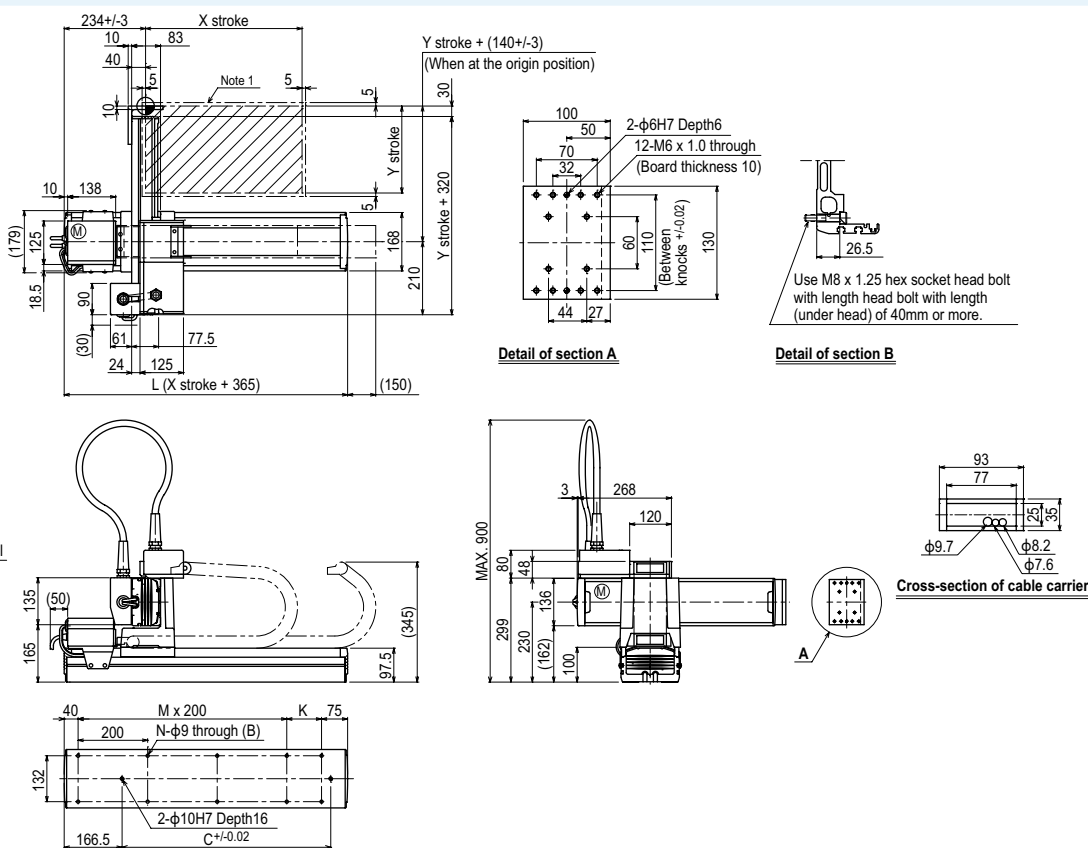

X stroke	250	350	450	550	650	750	850	950	1050	1150	1250	
L	615	715	815	915	1015	1115	1215	1315	1415	1515	1615	
K	100	200	100	200	100	200	100	200	100	200	100	
D	240	420	600	600	780	780	960	960	1140	1140	1320	
M	2	2	3	3	4	4	5	5	6	6	7	
N	8	8	10	10	12	12	14	14	16	16	18	
Y stroke	150	250	350	450	550							
Maximum speed for each stroke (mm/sec) <small>Note 3</small>	X-axis		1200				960		840	720	600	480
Speed setting			-				80%		70%	60%	50%	40%

Note 1. The moving range when returning to origin and the stop position when stopping by the mechanical stopper.
 Note 2. User cable extraction port.

Note 3. When the X-axis stroke is longer than 850mm, resonance of the ball screw may occur depending on the operation conditions (critical speed). In this case, reduce the speed setting on the program by referring to the maximum speeds shown in the table at the left.

MXyX 2 axes **M3**

Detail of section A
100, 50, 70, 32, 2-φ6H7 Depth6, 12-M6 x 1.0 through (Board thickness 10), 60, 110, 130, 27, 44, (Between knockouts +0.02)

Detail of section B
26.5, Use M8 x 1.25 hex socket head bolt with length head bolt with length (under head) of 40mm or more.

Cross-section of cable carrier
93, 77, φ9.7, φ8.2, φ7.6

Y stroke + 320
30, 210, 168, 5, 5, 5, 5, 234+/-3, 83, 10, 40, 10, 10, 138, 10, 125, 18.5, (179), 18.5, 125, 24, 77.5, 61, 30, 1.00, L (X stroke + 365), (150)

MAX. 900
268, 3, 120, 48, 80, 100, 136, 230, 299, (162), A

Grounding terminal (M4)
φ29 (Note 2), 5.5, 103.5, 80, 37, 135, 165, 50, 75, K, M x 200, 40, N-φ9 through (B), 200, 2-φ10H7 Depth16, C+/-0.02, 166.5, 132

X stroke	250	350	450	550	650	750	850	950	1050	1150	1250
L	615	715	815	915	1015	1115	1215	1315	1415	1515	1615
K	100	200	100	200	100	200	100	200	100	200	100
D	240	420	600	600	780	780	960	960	1140	1140	1320
M	2	2	3	3	4	4	5	5	6	6	7
N	8	8	10	10	12	12	14	14	16	16	18
Y stroke	150	250	350	450	550						
Maximum speed for each stroke (mm/sec) ^{Note 3}	X-axis		1200				960	840	720	600	480
Speed setting			-				80%	70%	60%	50%	40%

Note 1. The moving range when returning to origin and the stop position when stopping by the mechanical stopper.
Note 2. User cable extraction port.
Note 3. When the X-axis stroke is longer than 850mm, resonance of the ball screw may occur depending on the operation conditions (critical speed). In this case, reduce the speed setting on the program by referring to the maximum speeds shown in the table at the left.

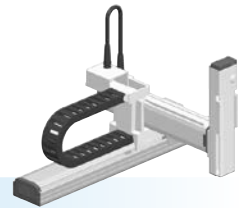

● Moving arm type ● Cable carrier ● Z-axis: clamped base / moving table type (200W)

Ordering method

MXYx - C							RCX340-3								
Model	Cable	Combination	X-axis stroke	Y-axis stroke	ZR-axis	Z-axis stroke	Cable	Controller / Number of controllable axes	Safety standard	Option A (OP.A)	Option B (OP.B)	Option C (OP.C)	Option D (OP.D)	Option E (OP.E)	Absolute battery
M1	M3	M1 M3	25 to 125cm	15 to 55cm	ZFL20 ZFL10	15 to 35cm	3L: 3.5m 5L: 5m 10L: 10m								

Specify various controller setting items. RCX340 ▶ **P.566**

Specification

	X-axis	Y-axis	Z-axis: ZFL20	Z-axis: ZFL10
Axis construction ^{Note 1}	F17	F14H	F10H-BK	
AC servo motor output (W)	400	200	200	
Repeatability ^{Note 2} (mm)	±0.01		±0.01	
Drive system	Ball screw φ20	Ball screw φ15	Ball screw φ15	
Ball screw lead ^{Note 3} (Deceleration ratio) (mm)	20	20	20	10
Maximum speed ^{Note 4} (mm/sec)	1200	1200	1200	600
Moving range (mm)	250 to 1250	150 to 550	150 to 350	
Robot cable length (m)	Standard: 3.5 Option: 5,10			

Note. The standard types are ZFL with higher rigidity as compared with ZF types which are conventional standard types. When you need the ZF type, please consult YAMAHA.

Note 1. Use caution that the flame machining (installation holes, tap holes) differs from single-axis robots.

Note 2. Positioning repeatability in one direction.

Note 3. Leads not listed in the catalog are also available. Contact us for details.

Note 4. When the X-axis stroke is longer than 850mm, resonance of the ball screw may occur depending on the operation conditions (critical speed). In this case, reduce the speed setting on the program by referring to the maximum speeds shown in the table below.

Maximum payload (kg)

Y stroke (mm)	Z stroke (mm)					
	ZFL20			ZFL10		
150	250	350	150	250	350	
150 to 550	8	8	8	12	11	10

Controller

Controller	Operation method
RCX340	Programming / I/O point trace / Remote command / Operation using RS-232C communication

MXYx 3 axes / ZFL20/10 (M1)

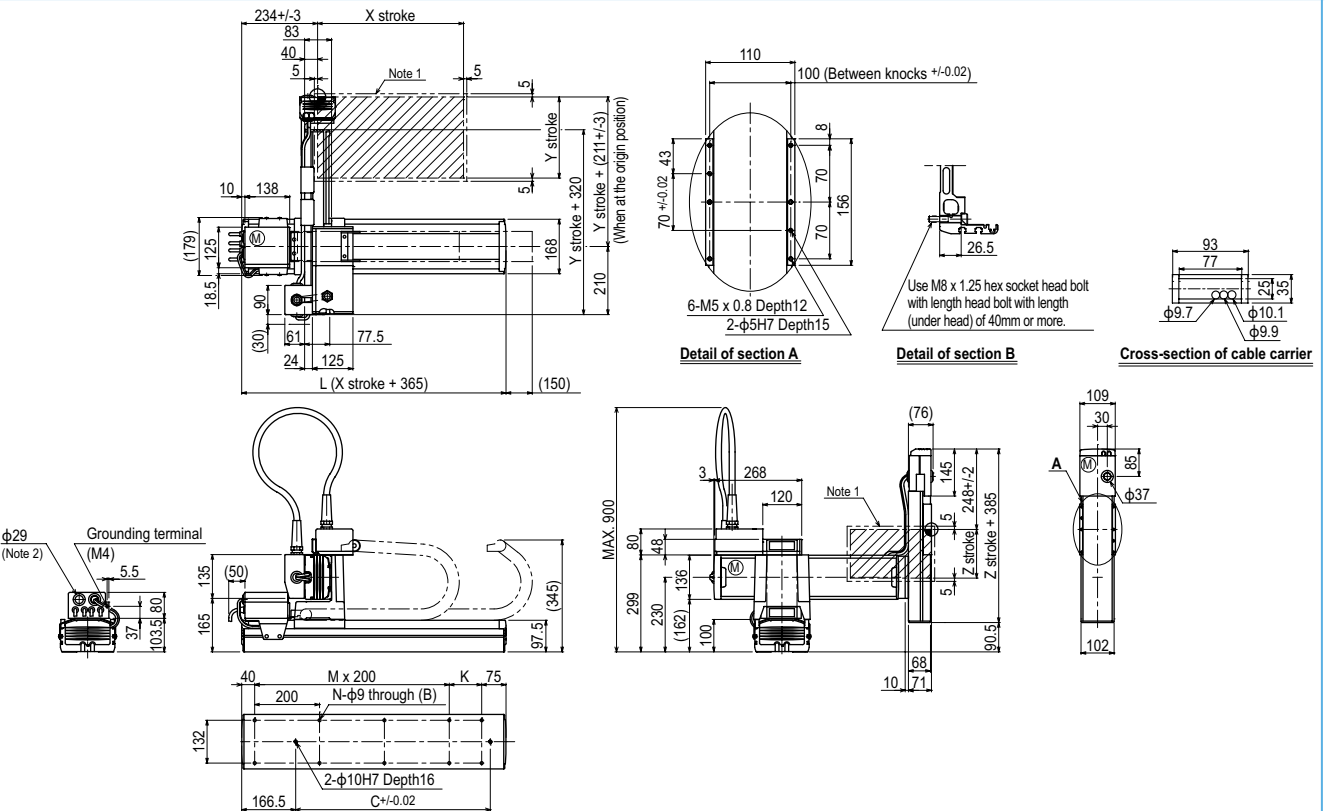

	X stroke												
	250	350	450	550	650	750	850	950	1050	1150	1250		
L	615	715	815	915	1015	1115	1215	1315	1415	1515	1615		
K	100	200	100	200	100	200	100	200	100	200	100		
C	240	420	600	600	780	780	960	960	1140	1140	1320		
M	2	2	3	3	4	4	5	5	6	6	7		
N	8	8	10	10	12	12	14	14	16	16	18		
Y stroke		150	250	350	450	550							
Z stroke		150	250	350									
Maximum speed for each stroke (mm/sec) ^{Note 3}	X-axis	1200					960	840	720	600	480		
	Speed setting	-					80%	70%	60%	50%	40%		

Note 1. The moving range when returning to origin and the stop position when stopping by the mechanical stopper.

Note 2. User cable extraction port.

Note 3. When the X-axis stroke is longer than 850mm, resonance of the ball screw may occur depending on the operation conditions (critical speed). In this case, reduce the speed setting on the program by referring to the maximum speeds shown in the table at the left.

MXYx 3 axes / ZFH

- Moving arm type
- Cable carrier
- Z-axis: clamped table / moving base type (200W)

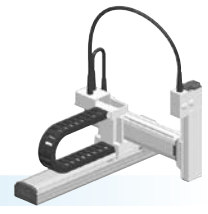

Ordering method

MXYx - C **ZFH** **RCX340-3**

Model	Cable	Combination	X-axis stroke	Y-axis stroke	ZR-axis	Z-axis stroke	Cable	Controller / Number of controllable axes	Safety standard	Option A (OP.A)	Option B (OP.B)	Option C (OP.C)	Option D (OP.D)	Option E (OP.E)	Absolute battery
		M1	25 to 125cm	15 to 55cm		15 to 35cm	3L: 3.5m 5L: 5m 10L: 10m	Specify various controller setting items. RCX340 ▶ P.566							

Specification

	X-axis	Y-axis	Z-axis
Axis construction <small>Note 1</small>	F17	F14H	F10H-BK
AC servo motor output (W)	400	200	200
Repeatability <small>Note 2 (mm)</small>	+/-0.01	+/-0.01	+/-0.01
Drive system	Ball screw φ20	Ball screw φ15	Ball screw φ15
Ball screw lead <small>Note 3</small> (Deceleration ratio) (mm)	20	20	10
Maximum speed <small>Note 4</small> (mm/sec)	1200	1200	600
Moving range (mm)	250 to 1250	150 to 550	150 to 350
Robot cable length (m)	Standard: 3.5 Option: 5, 10		

Maximum payload (kg)

Y stroke (mm)	Z stroke (mm)		
	150	250	350
150 to 550	12	11	10

Controller

Controller	Operation method
RCX340	Programming / I/O point trace / Remote command / Operation using RS-232C communication

Note. The standard types are ZFH with higher rigidity as compared with ZF types which are conventional standard types. When you need the ZF type, please consult YAMAHHA.

Note 1. Use caution that the flame machining (installation holes, tap holes) differs from single-axis robots.

Note 2. Positioning repeatability in one direction.

Note 3. Leads not listed in the catalog are also available. Contact us for details.

Note 4. When the X-axis stroke is longer than 850mm, resonance of the ball screw may occur depending on the operation conditions (critical speed). In this case, reduce the speed setting on the program by referring to the maximum speeds shown in the table below.

MXYx 3 axes / ZFH M1

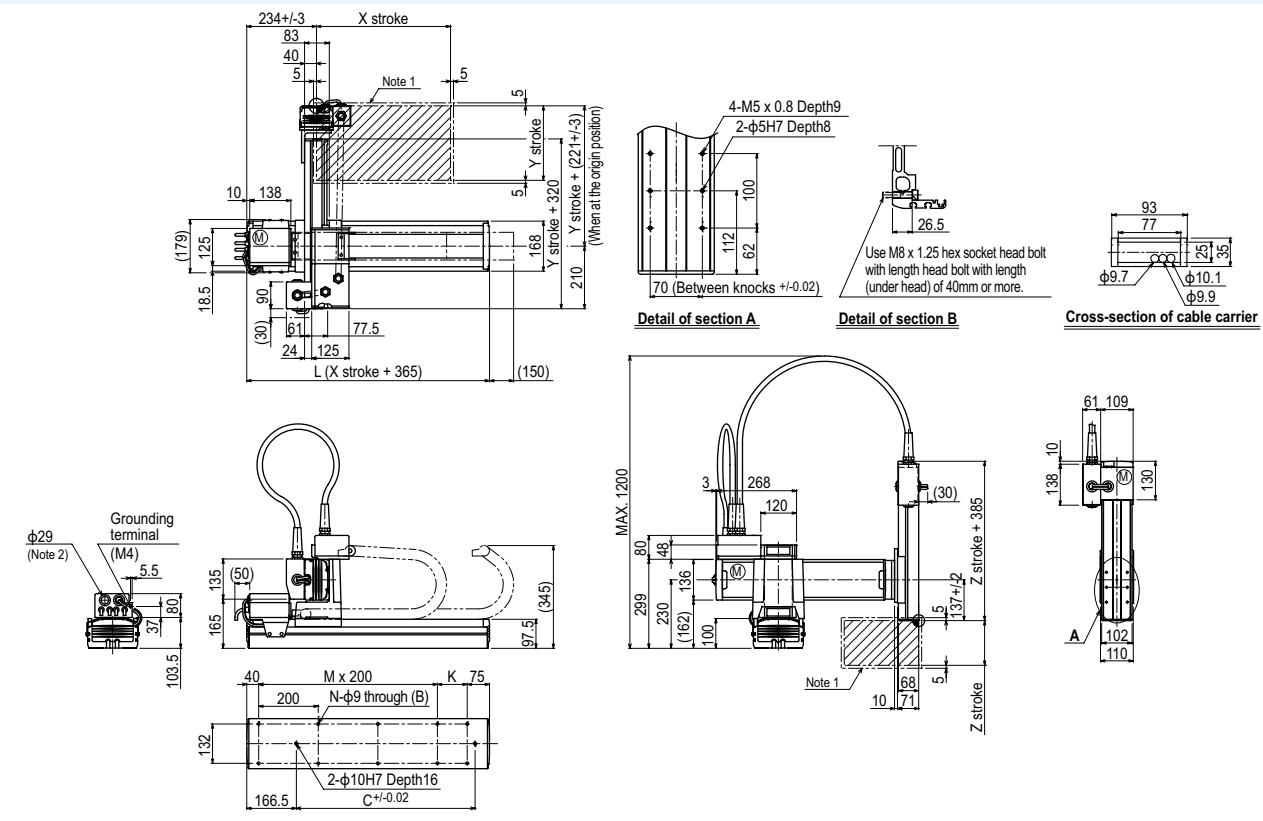

X stroke <small>Note 3</small>													
	250	350	450	550	650	750	850	950	1050	1150	1250		
L	615	715	815	915	1015	1115	1215	1315	1415	1515	1615		
K	100	200	100	200	100	200	100	200	100	200	100		
D	240	420	600	600	780	780	960	960	1140	1140	1320		
M	2	2	3	3	4	4	5	5	6	6	7		
N	8	8	10	10	12	12	14	14	16	16	18		
Y stroke <small>Note 3</small>	150			250			350			550			
Z stroke	150			250			350						
Maximum speed for each stroke (mm/sec) <small>Note 4</small>	X-axis		1200										
	Speed setting		-										
			960			840		720		600		480	
			80%			70%		60%		50%		40%	

Note 1. The moving range when returning to origin and the stop position when stopping by the mechanical stopper.

Note 2. User cable extraction port.

Note 3. The total of the Y and Z strokes should be 800mm or less.

Note 4. When the X-axis stroke is longer than 850mm, resonance of the ball screw may occur depending on the operation conditions (critical speed). In this case, reduce the speed setting on the program by referring to the maximum speeds shown in the table at the left.

- Articulated robots
- YA
- Linear conveyor modules
- LCM100
- Motor-less single axis actuator
- Robonity
- Compact single-axis robots
- TRANSEVO
- Single-axis robots
- FLIP-X
- Linear motor single-axis robots
- PHASER
- Cartesian robots
- XY-X
- SCARA robots
- YK-X
- Pick & place robots
- YP-X
- CLEAN
- CONTROLLER INFORMATION
- Arm type
- Gantry type
- Moving arm type
- Pole type
- XZ type

HXYx 2 axes

- Moving arm type
- Cable carrier

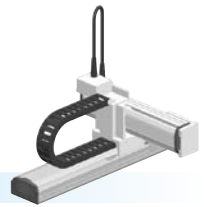

Ordering method

HXYx - C

Model	Cable	Combination	X-axis stroke	Y-axis stroke	Cable
M1	M1		25 to 125cm	25 to 65cm	3L: 3.5m
M3	M3				5L: 5m
					10L: 10m

RCX320-2

Controller / Number of controllable axes	Safety standard	Regenerative unit	Option A (OP.A)	Option B (OP.B)	Vision System	Absolute battery

Specify various controller setting items. RCX320 ▶ **P.548**

RCX222HP

Controller	Usable for CE	Regenerative unit	I/O selection 1	I/O selection 2

Specify various controller setting items. RCX222 ▶ **P.558**

Specification

	X-axis	Y-axis
Axis construction ^{Note 1}	F20	F17
AC servo motor output (W)	600	400
Repeatability ^{Note 2} (mm)	+/-0.01	+/-0.01
Drive system	Ball screw φ20	Ball screw φ20
Ball screw lead ^{Note 3} (Deceleration ratio) (mm)	20	20
Maximum speed ^{Note 4} (mm/sec)	1200	1200
Moving range (mm)	250 to 1250	250 to 650
Robot cable length (m)	Standard: 3.5 Option: 5,10	

- Note 1. Use caution that the flame machining (installation holes, tap holes) differs from single-axis robots.
 Note 2. Positioning repeatability in one direction.
 Note 3. Leads not listed in the catalog are also available. Contact us for details.
 Note 4. When the X-axis stroke is longer than 850mm, resonance of the ball screw may occur depending on the operation conditions (critical speed). In this case, reduce the speed setting on the program by referring to the maximum speeds shown in the table below.

Maximum payload (kg)

Y stroke (mm)	XY 2 axes
250 to 650	30

Controller

Controller	Operation method
RCX320-R	Programming / I/O point trace / Remote command / Operation using RS-232C communication
RCX222HP-R	

HXYx 2 axes M1

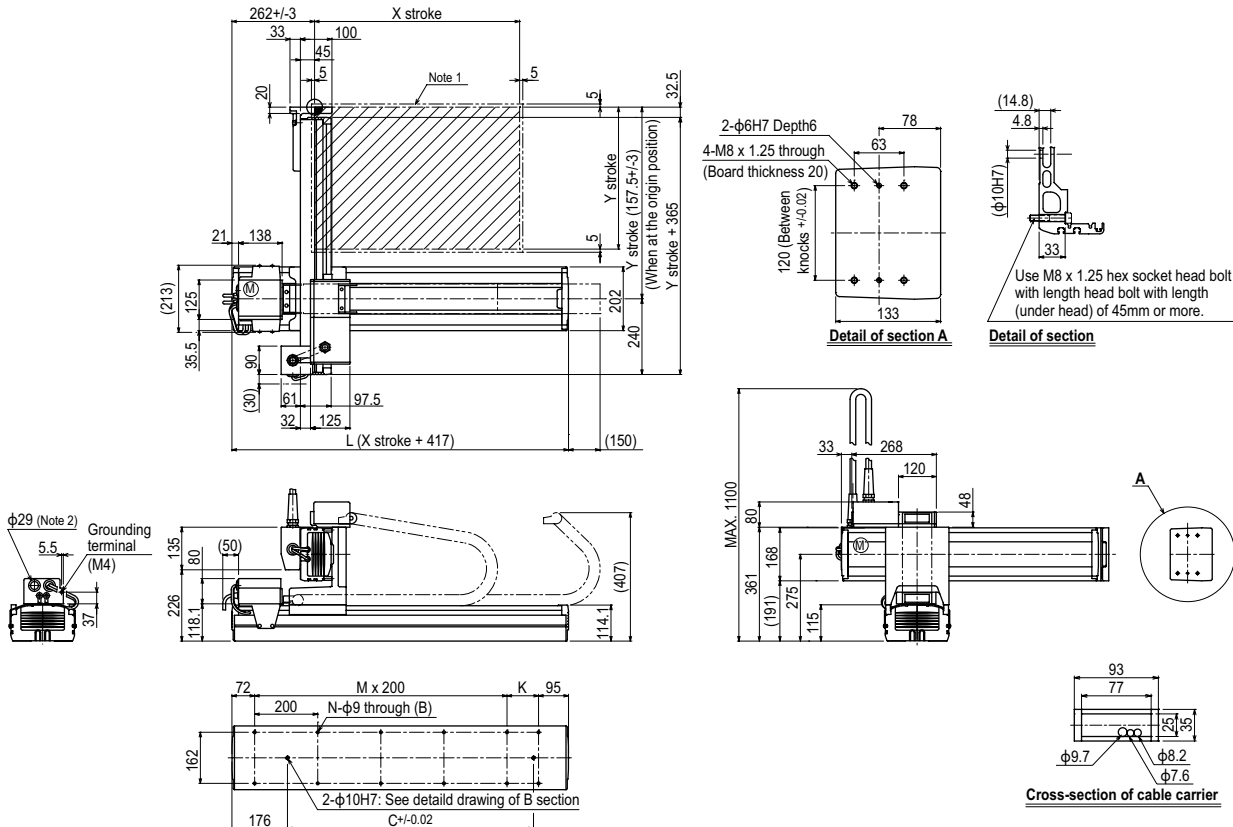

X stroke	250	350	450	550	650	750	850	950	1050	1150	1250
L	667	767	867	967	1067	1167	1267	1367	1467	1567	1667
K	100	200	100	200	100	200	100	200	100	200	100
C	420	420	600	600	780	780	960	960	1140	1320	1320
M	2	2	3	3	4	4	5	5	6	6	7
N	8	8	10	10	12	12	14	14	16	16	18
Y stroke	250	350	450	550	650						
Maximum speed for each stroke (mm/sec) ^{Note 3}	X-axis		1200				960	840	720	600	480
Speed setting			-				80%	70%	60%	50%	40%

- Note 1. The moving range when returning to origin and the stop position when stopping by the mechanical stopper.
 Note 2. User cable extraction port.

Note 3. When the X-axis stroke is longer than 850mm, resonance of the ball screw may occur depending on the operation conditions (critical speed). In this case, reduce the speed setting on the program by referring to the maximum speeds shown in the table at the left.

HXYx 2 axes **M3**

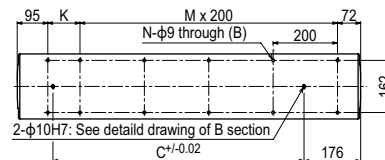
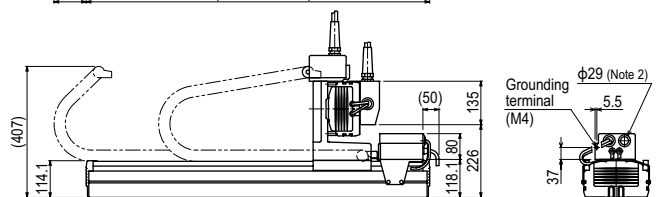
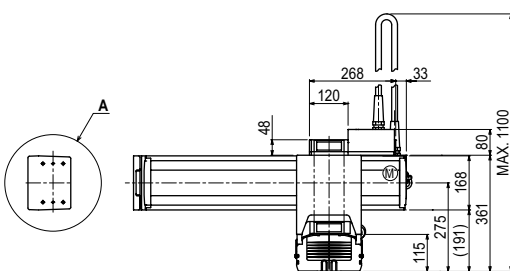
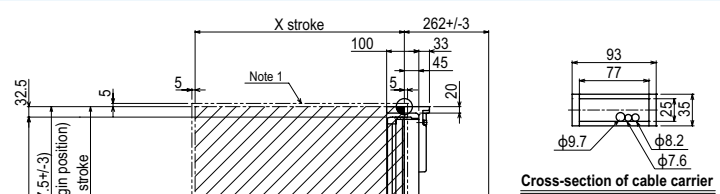
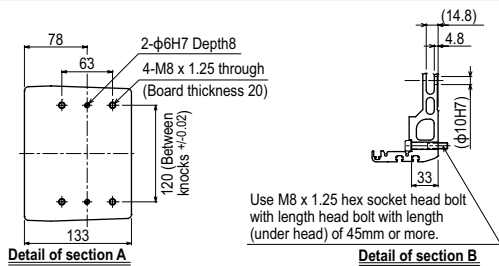

X stroke	250	350	450	550	650	750	850	950	1050	1150	1250	
L	667	767	867	967	1067	1167	1267	1367	1467	1567	1667	
K	100	200	100	200	100	200	100	200	100	200	100	
C	420	420	600	600	780	780	960	960	1140	1320	1320	
M	2	2	3	3	4	4	5	5	6	6	7	
N	8	8	10	10	12	12	14	14	16	16	18	
Y stroke	250	350	450	550	650							
Maximum speed for each stroke (mm/sec) Note 3	X-axis		1200					960	840	720	600	480
	Speed setting		-					80%	70%	60%	50%	40%

Note 1. The moving range when returning to origin and the stop position when stopping by the mechanical stopper.
Note 2. User cable extraction port.
Note 3. When the X-axis stroke is longer than 850mm, resonance of the ball screw may occur depending on the operation conditions (critical speed). In this case, reduce the speed setting on the program by referring to the maximum speeds shown in the table at the left.

HXYx 3 axes / ZH

- Moving arm type
- Cable carrier
- Z-axis: clamped table / moving base type (200W)

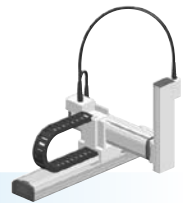

Ordering method

HXYx - C [] [] [] **ZH** [] [] **RCX340-3** [] [] [] [] [] [] [] [] [] [] []

Model	Cable	Combination	X-axis stroke	Y-axis stroke	ZR-axis	Z-axis stroke	Cable	Controller / Number of controllable axes	Safety standard	Option A (OP.A)	Option B (OP.B)	Option C (OP.C)	Option D (OP.D)	Option E (OP.E)	Absolute battery
		M1 M3	25 to 125cm	25 to 65cm		25 to 55cm	3L: 3.5m 5L: 5m 10L: 10m								

Specify various controller setting items. RCX340 ▶ **P.566**

Specification

	X-axis	Y-axis	Z-axis
Axis construction ^{Note 1}	F20	F17	F14H-BK
AC servo motor output (W)	600	400	200
Repeatability ^{Note 2} (mm)	+/-0.01	+/-0.01	+/-0.01
Drive system	Ball screw φ20	Ball screw φ20	Ball screw φ15
Ball screw lead ^{Note 3} (Deceleration ratio) (mm)	20	20	5
Maximum speed ^{Note 4} (mm/sec)	1200	1200	300
Moving range (mm)	250 to 1250	250 to 650	250 to 550
Robot cable length (m)	Standard: 3.5 Option: 5, 10		

Note 1. Use caution that the flange machining (installation holes, tap holes) differs from single-axis robots.
 Note 2. Positioning repeatability in one direction.
 Note 3. Leads not listed in the catalog are also available. Contact us for details.
 Note 4. When the X-axis stroke is longer than 850mm, resonance of the ball screw may occur depending on the operation conditions (critical speed). In this case, reduce the speed setting on the program by referring to the maximum speeds shown in the table below.

Maximum payload (kg)

Y stroke (mm)	Z stroke (mm)				
	250	350	450	550	650
250	18	18	18	18	18
350	18	18	18	18	18
450	18	18	18	18	18
550	18	17	16	15	15
650	18	17	16	15	15

Controller

Controller	Operation method
RCX340	Programming / I/O point trace / Remote command / Operation using RS-232C communication

HXYx 3 axes / ZH M1

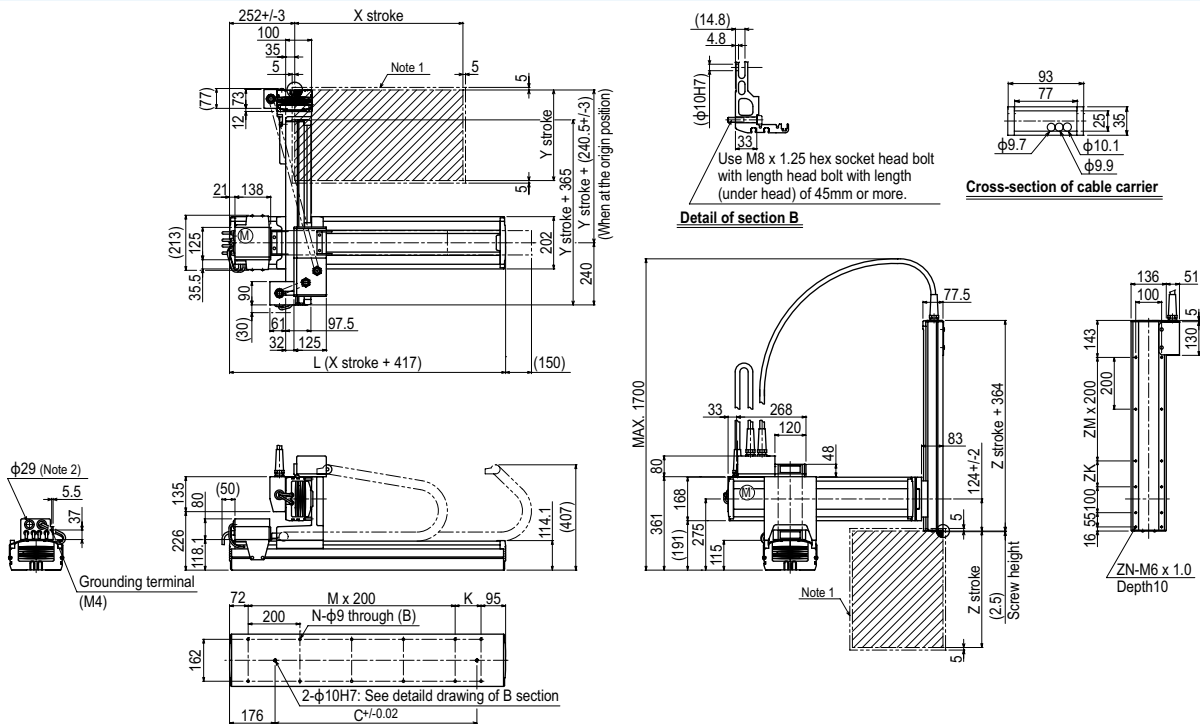

X stroke	Stroke (mm)										
	250	350	450	550	650	750	850	950	1050	1150	1250
L	667	767	867	967	1067	1167	1267	1367	1467	1567	1667
K	100	200	100	200	100	200	100	200	100	200	100
C	420	420	600	600	780	780	960	960	1140	1320	1320
M	2	2	3	3	4	4	5	5	6	6	7
N	8	8	10	10	12	12	14	14	16	16	18
Y stroke	250	350	450	550	650						
Z stroke	250	350	450	550							
ZK	100	200	100	200							
ZM	1	1	2	2							
ZN	10	10	12	12							

Note 1. The moving range when returning to origin and the stop position when stopping by the mechanical stopper.
 Note 2. User cable extraction port.

Note 3. When the X-axis stroke is longer than 850mm, resonance of the ball screw may occur depending on the operation conditions (critical speed). In this case, reduce the speed setting on the program by referring to the maximum speeds shown in the table at the left.

Maximum speed for each stroke (mm/sec) ^{Note 3}	X-axis		Y-axis		Z-axis		
	Speed setting	80%	70%	60%	50%	40%	
		1200	960	840	720	600	480

Articulated robots
YA

Linear conveyor
modules
LCM100

Motor-less single
axis actuator
Robonity

Compact
single-axis robots
TRANSERVO

Single-axis robots
FLIP-X

Linear motor
single-axis robots
PHASER

Cartesian
robots
XY-X

SCARA
robots
YK-X

Pick & place
robots
YP-X

CLEAN

CONTROLLER

INFORMATION

Arm type

Gantry type

Moving arm
type

Pole type

XZ type

SXYx 2 axes

● Pole type ● Whipover



Ordering method

SXYx - S - P1

Model	Cable	Combination	X-axis stroke ^{Note 1}	Y-axis stroke ^{Note 1}	Cable
			15 to 85cm	15 to 55cm	3L: 3.5m 5L: 5m 10L: 10m

RCX320-2

Controller / Number of controllable axes	Safety standard	Option A (O.P.A)	Option B (O.P.B)	Vision System	Absolute battery
--	-----------------	------------------	------------------	---------------	------------------

Specify various controller setting items. RCX320 ▶ **P.548**

RCX222

Controller	Usable for CE	I/O selection 1	I/O selection 2
------------	---------------	-----------------	-----------------

Specify various controller setting items. RCX222 ▶ **P.558**

Note 1. The total of the X and Y strokes should be 1100mm or less.

Specification

	X-axis	Y-axis
Axis construction ^{Note 1}	F14H	F14-BK
AC servo motor output (W)	200	100
Repeatability ^{Note 2} (mm)	+/-0.01	+/-0.01
Drive system	Ball screw φ15	Ball screw φ15
Ball screw lead ^{Note 3} (Deceleration ratio) (mm)	20	10
Maximum speed ^{Note 4} (mm/sec)	1200	600
Moving range (mm)	150 to 850	150 to 550
Robot cable length (m)	Standard: 3.5 Option: 5, 10	

Note 1. Use caution that the flange machining (installation holes, tap holes) differs from single-axis robots'.
 Note 2. Positioning repeatability in one direction.
 Note 3. Leads not listed in the catalog are also available. Contact us for details.
 Note 4. When the X-axis stroke is longer than 750mm, resonance of the ball screw may occur depending on the operation conditions (critical speed). In this case, reduce the speed setting on the program by referring to the maximum speeds shown in the table below.

Maximum payload (kg)

Y stroke (mm)	XY 2 axes
150 to 550	8

Controller

Controller	Operation method
RCX320 RCX222	Programming / I/O point trace / Remote command / Operation using RS-232C communication

SXYx 2 axes P1

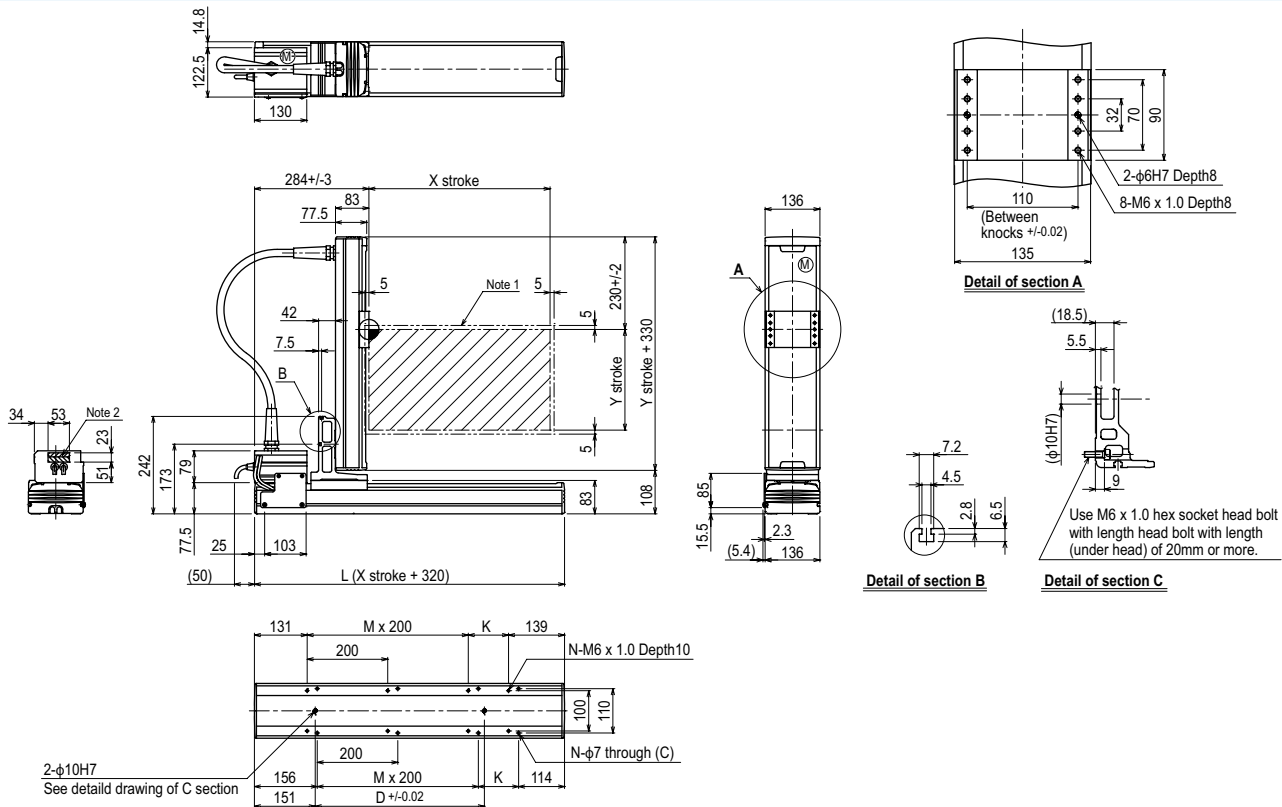

X stroke ^{Note 3}	150	250	350	450	550	650	750	850
L	470	570	670	770	870	970	1070	1170
K	200	100	200	100	200	100	200	100
D	240	240	420	420	600	600	780	780
M	0	1	1	2	2	3	3	4
N	4	6	6	8	8	10	10	12
Y stroke ^{Note 3}	150	250	350	450	550			
Maximum speed for each stroke (mm/sec) ^{Note 4}	X-axis		1200			960		780
Speed setting			-			80%		65%

Note 1. The moving range when returning to origin and the stop position when stopping by the mechanical stopper.

Note 2. The shaded position indicates a user cable extraction port.

Note 3. The total of the X and Y strokes should be 1100mm or less.

Note 4. When the X-axis stroke is longer than 750mm, resonance of the ball screw may occur depending on the operation conditions (critical speed). In this case, reduce the speed setting on the program by referring to the maximum speeds shown in the table at the left.

MXYx 2 axes

● Pole type ● Cable carrier

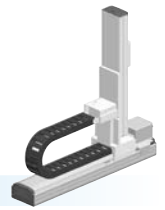

Ordering method

MXYx - C - P2

Model	Cable	Combination	X-axis stroke 25 to 125cm	Y-axis stroke 15 to 65cm	Cable 3L: 3.5m 5L: 5m 10L: 10m
-------	-------	-------------	------------------------------	-----------------------------	---

RCX320-2 **R**

Controller / Number of controllable axes	Safety standard	Regenerative unit	Option A (O.P.A)	Option B (O.P.B)	Vision System	Absolute battery
--	-----------------	-------------------	------------------	------------------	---------------	------------------

Specify various controller setting items. RCX320 ▶ **P548**

RCX222 **R**

Controller	Usable for CE	Regenerative unit	I/O selection 1	I/O selection 2
------------	---------------	-------------------	-----------------	-----------------

Specify various controller setting items. RCX222 ▶ **P558**

Specification

	X-axis	Y-axis
Axis construction ^{Note 1}	F17	F14H-BK
AC servo motor output (W)	400	200
Repeatability ^{Note 2} (mm)	+/-0.01	+/-0.01
Drive system	Ball screw φ20	Ball screw φ15
Ball screw lead ^{Note 3} (Deceleration ratio) (mm)	20	10
Maximum speed ^{Note 4} (mm/sec)	1200	600
Moving range (mm)	250 to 1250	150 to 650
Robot cable length (m)	Standard: 3.5 Option: 5,10	

Note 1. Use caution that the flame machining (installation holes, tap holes) differs from single-axis robots.
 Note 2. Positioning repeatability in one direction.
 Note 3. Leads not listed in the catalog are also available. Contact us for details.
 Note 4. When the X-axis stroke is longer than 850mm, resonance of the ball screw may occur depending on the operation conditions (critical speed). In this case, reduce the speed setting on the program by referring to the maximum speeds shown in the table below.

Maximum payload (kg)

Y stroke (mm)	XY 2 axes
150 to 650	20

Controller

Controller	Operation method
RCX320-R RCX222-R	Programming / I/O point trace / Remote command / Operation using RS-232C communication

MXYx 2 axes P2

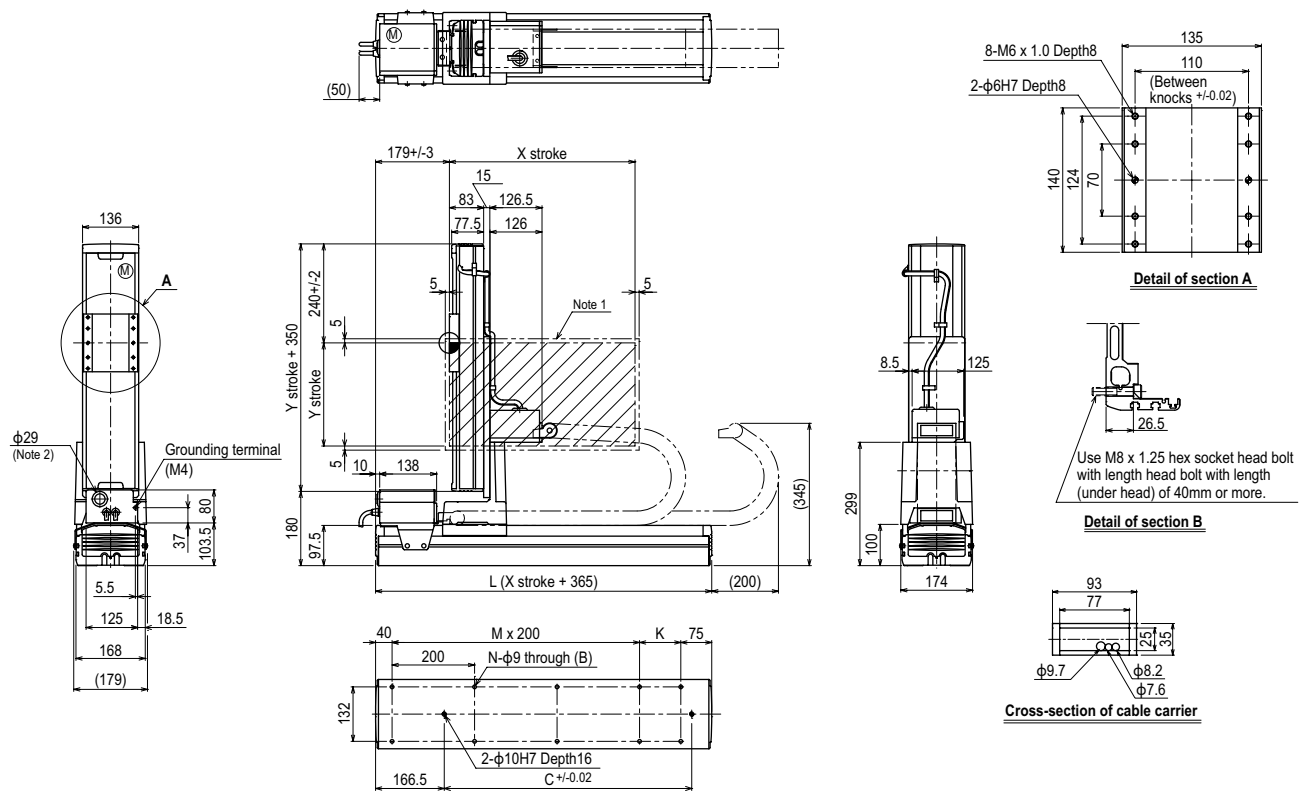

X stroke	250	350	450	550	650	750	850	950	1050	1150	1250
L	615	715	815	915	1015	1115	1215	1315	1415	1515	1615
K	100	200	100	200	100	200	100	200	100	200	100
C	240	420	600	600	780	780	960	960	1140	1140	1320
M	2	2	3	3	4	4	5	5	6	6	7
N	8	8	10	10	12	12	14	14	16	16	18
Y stroke	150	250	350	450	550	650					
Maximum speed for each stroke (mm/sec) ^{Note 3}	X-axis		1200				960	840	720	600	480
Speed setting			-				80%	70%	60%	50%	40%

Note 1. The moving range when returning to origin and the stop position when stopping by the mechanical stopper.
 Note 2. User cable extraction port.

Note 3. When the X-axis stroke is longer than 850mm, resonance of the ball screw may occur depending on the operation conditions (critical speed). In this case, reduce the speed setting on the program by referring to the maximum speeds shown in the table at the left.

Articulated robots
YA
Linear conveyor modules
LCM100
Motor-less single axis actuator
Robonity
Compact single-axis robots
TRANSEVO
Single-axis robots
FLIP-X
Linear motor single-axis robots
PHASER
Cartesian robots
XY-X
SCARA robots
YK-X
Pick & place robots
YP-X
CLEAN
CONTROLLER INFORMATION
Arm type
Gantry type
Moving arm type
Pole type
XZ type

MXYx 2 axes

● Pole type ● Whipover



Ordering method

MXYx - S - P1

Model	Cable	Combination	X-axis stroke ^{Note 3}	Y-axis stroke ^{Note 1}	Cable
			25 to 95cm	15 to 65cm	3L: 3.5m 5L: 5m 10L: 10m

RCX320-2 **R**

Controller / Number of controllable axes	Safety standard	Regenerative unit	Option A (OP.A)	Option B (OP.B)	Vision System	Absolute battery
--	-----------------	-------------------	-----------------	-----------------	---------------	------------------

Specify various controller setting items. RCX320 ▶ P.548

RCX222 **R**

Controller	Usable for CE	Regenerative unit	I/O selection 1	I/O selection 2
------------	---------------	-------------------	-----------------	-----------------

Specify various controller setting items. RCX222 ▶ P.558

Note 1. The total of the X and Y strokes should be 1100mm or less.

Specification

	X-axis	Y-axis
Axis construction ^{Note 1}	F17	F14H-BK
AC servo motor output (W)	400	200
Repeatability ^{Note 2} (mm)	+/-0.01	+/-0.01
Drive system	Ball screw φ20	Ball screw φ15
Ball screw lead ^{Note 3} (Deceleration ratio) (mm)	20	10
Maximum speed ^{Note 4} (mm/sec)	1200	600
Moving range (mm)	250 to 950	150 to 650
Robot cable length (m)	Standard: 3.5 Option: 5,10	

Note 1. Use caution that the flame machining (installation holes, tap holes) differs from single-axis robots.
 Note 2. Positioning repeatability in one direction.
 Note 3. Leads not listed in the catalog are also available. Contact us for details.
 Note 4. When the X-axis stroke is longer than 850mm, resonance of the ball screw may occur depending on the operation conditions (critical speed). In this case, reduce the speed setting on the program by referring to the maximum speeds shown in the table below.

Maximum payload (kg)

Y stroke (mm)	XY 2 axes
150 to 650	20

Controller

Controller	Operation method
RCX320-R	Programming / I/O point trace / Remote command / Operation using RS-232C communication
RCX222-R	

MXYx 2 axes P1

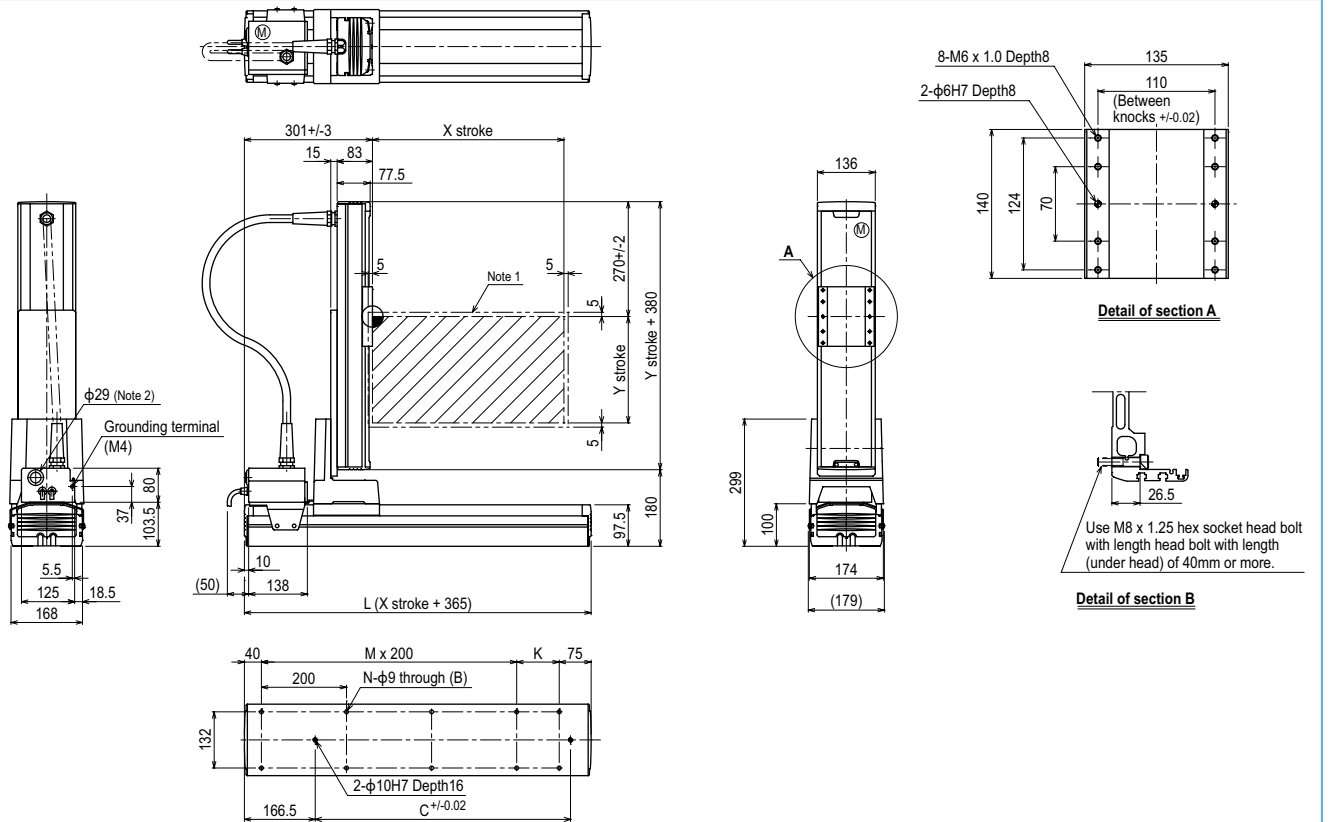

X stroke ^{Note 3}	250	350	450	550	650	750	850	950
L	615	715	815	915	1015	1115	1215	1315
K	100	200	100	200	100	200	100	200
C	240	420	600	600	780	780	960	960
M	2	2	3	3	4	4	5	5
N	8	8	10	10	12	12	14	14
Y stroke ^{Note 3}	150	250	350	450	550	650		
Maximum speed for each stroke (mm/sec) ^{Note 4}	X-axis		1200			960		840
Speed setting			-			80%		70%

Note 1. The moving range when returning to origin and the stop position when stopping by the mechanical stopper.
 Note 2. User cable extraction port.
 Note 3. The total of the X and Y strokes should be 1100mm or less.
 Note 4. When the X-axis stroke is longer than 850mm, resonance of the ball screw may occur depending on the operation conditions (critical speed). In this case, reduce the speed setting on the program by referring to the maximum speeds shown in the table at the left.

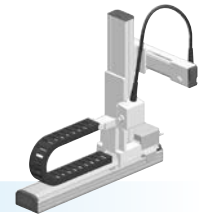

Ordering method

MXYx - C - P2							RCX340-3									
Model	Cable	Combination	X-axis stroke 25 to 125cm	Y-axis stroke 15 to 65cm	ZR-axis ZPMHL ZPMHR	Z-axis stroke 15 to 35cm	Cable 3L: 3.5m 5L: 5m 10L: 10m	Controller / Number of controllable axes	Safety standard	Option A (OP.A)	Option B (OP.B)	Option C (OP.C)	Option D (OP.D)	Option E (OP.E)	Absolute battery	

Specify various controller setting items. RCX340 ▶ **P.566**

Specification

	X-axis	Y-axis	Z-axis
Axis construction ^{Note 1}	F17	F14H-BK	F10H-BK
AC servo motor output (W)	400	200	200
Repeatability ^{Note 2} (mm)	+/-0.01	+/-0.01	+/-0.01
Drive system	Ball screw φ20	Ball screw φ15	Ball screw φ15
Ball screw lead ^{Note 3} (Deceleration ratio) (mm)	20	10	20
Maximum speed ^{Note 4} (mm/sec)	1200	600	1200
Moving range (mm)	250 to 1250	150 to 650	150 to 350
Robot cable length (m)	Standard: 3.5 Option: 5,10		

Note. The standard types are ZPMH with higher rigidity as compared with ZPM types which are conventional standard types. When you need the ZPM type, please consult YAMAHA.

Note 1. Use caution that the flame machining (installation holes, tap holes) differs from single-axis robots.

Note 2. Positioning repeatability in one direction.

Note 3. Leads not listed in the catalog are also available. Contact us for details.

Note 4. When the X-axis stroke is longer than 850mm, resonance of the ball screw may occur depending on the operation conditions (critical speed). In this case, reduce the speed setting on the program by referring to the maximum speeds shown in the table below.

Maximum payload (kg)

Y stroke (mm)	Z stroke (mm)		
	150	250	350
150 to 650	10	9	8

Controller

Controller	Operation method
RCX340	Programming / I/O point trace / Remote command / Operation using RS-232C communication

MXYx 3 axes / ZPMHL (P2)

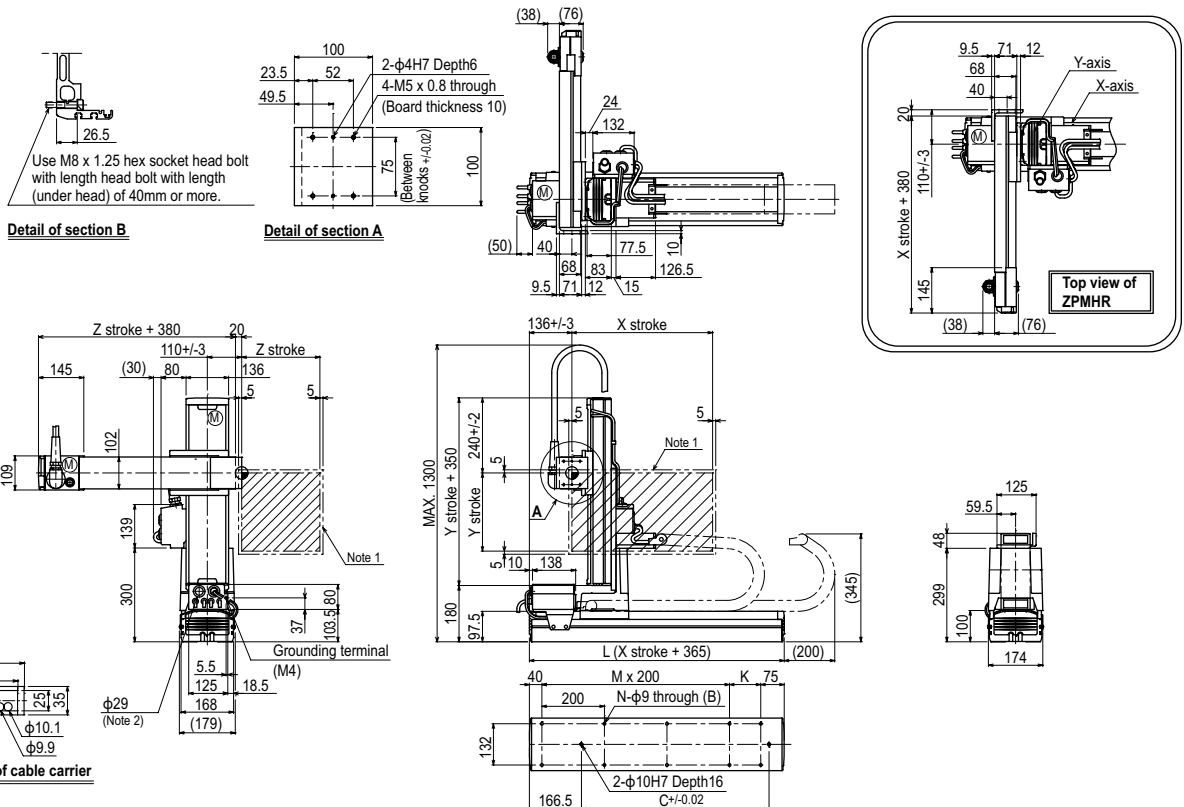

Use M8 x 1.25 hex socket head bolt with length head bolt with length (under head) of 40mm or more.

Detail of section B

Detail of section A

Top view of ZPMHR

Cross-section of cable carrier

X stroke	250	350	450	550	650	750	850	950	1050	1150	1250	
	L	615	715	815	915	1015	1115	1215	1315	1415	1515	1615
K	100	200	100	200	100	200	100	200	100	200	100	
C	240	420	600	600	780	780	960	960	1140	1140	1320	
M	2	2	3	3	4	4	5	5	6	6	7	
N	8	8	10	10	12	12	14	14	16	16	18	
Y stroke	150	250	350	450	550	650						
Z stroke	150	250	350									
Maximum speed for each stroke (mm/sec) ^{Note 3}	X-axis	1200					960	840	720	600	480	
	Speed setting	-					80%	70%	60%	50%	40%	

Note 1. The moving range when returning to origin and the stop position when stopping by the mechanical stopper.

Note 2. User cable extraction port.

Note 3. This figure shows the combination for ZPMHL. For the combination for ZPMHR, see the top view in the figure.

Note 4. When the X-axis stroke is longer than 850mm, resonance of the ball screw may occur depending on the operation conditions (critical speed). In this case, reduce the speed setting on the program by referring to the maximum speeds shown in the table at the left.

Articulated robots
YA
Linear conveyor modules
LCM100
Motor-less single-axis actuator
Robonity
Compact single-axis robots
TRANSEVO
Single-axis robots
FLIP-X
Linear motor single-axis robots
PHASER
Cartesian robots
XX-X
SCARA robots
YK-X
Pick & place robots
YP-X
CLEAN
CONTROLLER INFORMATION
Arm type
Gantry type
Moving arm type
Pole type
XZ type

HXYx 2 axes

● Pole type ● Cable carrier

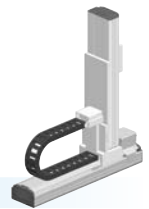

Ordering method

HXYx - C - P2 **RCX320-2** **R**

Model	Cable	Combination	X-axis stroke 25 to 125cm	Y-axis stroke 25 to 105cm	Cable 3L: 3.5m 5L: 5m 10L: 10m	Controller / Number of controllable axes	Safety standard	Regenerative unit	Option A (OP.A)	Option B (OP.B)	Vision System	Absolute battery
-------	-------	-------------	------------------------------	------------------------------	---	---	--------------------	-------------------	--------------------	--------------------	------------------	---------------------

Specify various controller setting items. RCX320 ▶ **P.548**

RCX222HP **R**

Controller	Usable for CE	Regenerative unit	I/O selection 1	I/O selection 2
------------	---------------	-------------------	-----------------	-----------------

Specify various controller setting items. RCX222 ▶ **P.558**

Specification

	X-axis	Y-axis
Axis construction ^{Note 1}	F20	F20-BK
AC servo motor output (W)	600	600
Repeatability ^{Note 2} (mm)	+/-0.01	+/-0.01
Drive system	Ball screw φ20	Ball screw φ20
Ball screw lead ^{Note 3} (Deceleration ratio) (mm)	20	10
Maximum speed ^{Note 4} (mm/sec)	1200	600
Moving range (mm)	250 to 1250	250 to 1050
Robot cable length (m)	Standard: 3.5 Option: 5, 10	

Note 1. Use caution that the flame machining (installation holes, tap holes) differs from single-axis robots.
 Note 2. Positioning repeatability in one direction.
 Note 3. Leads not listed in the catalog are also available. Contact us for details.
 Note 4. When the X-axis/Y-axis stroke is longer than 850mm, resonance of the ball screw may occur depending on the operation conditions (critical speed). In this case, reduce the speed setting on the program by referring to the maximum speeds shown in the table below.

Maximum payload (kg)

Y stroke (mm)	XY 2 axes
250 to 1050	30

Controller

Controller	Operation method
RCX320-R	Programming / I/O point trace / Remote command / Operation using RS-232C communication
RCX222HP-R	Programming / I/O point trace / Remote command / Operation using RS-232C communication

HXYx 2 axes P2

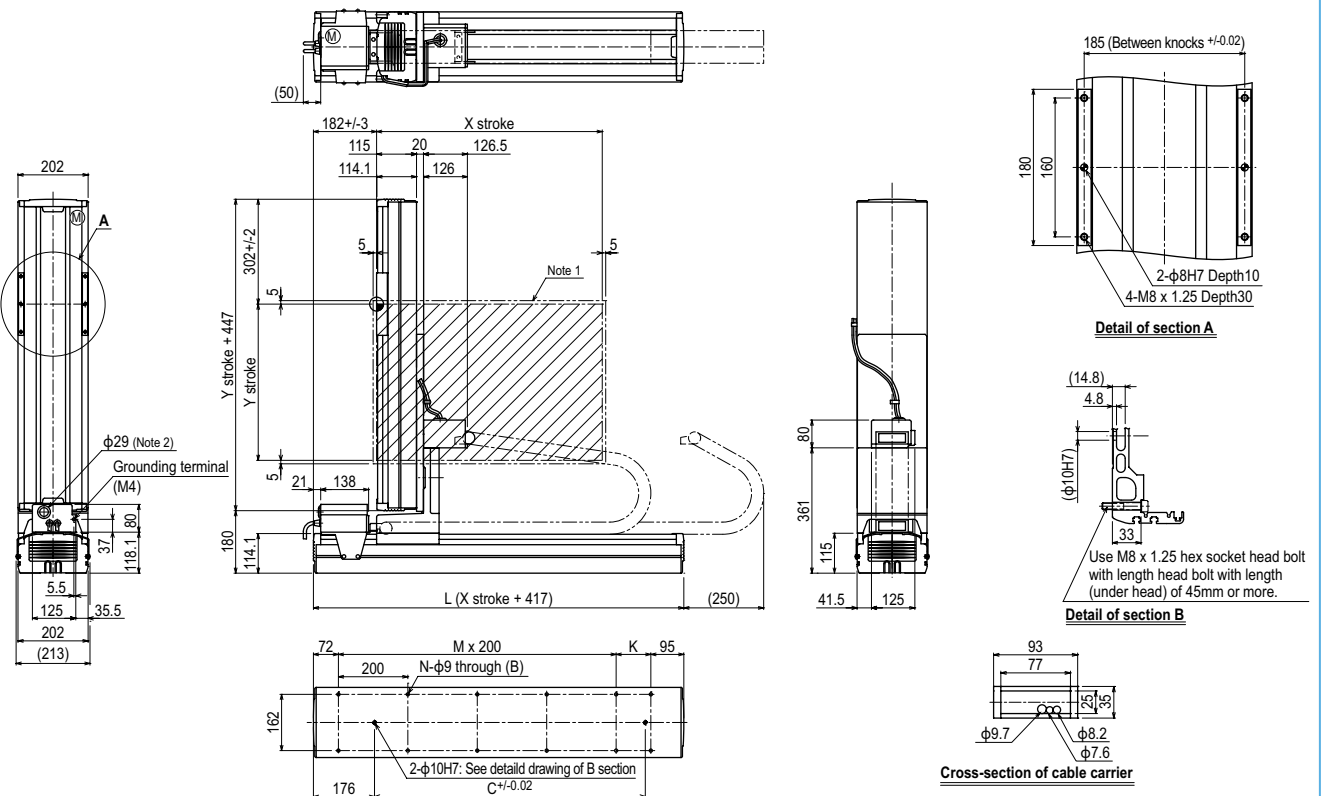

X stroke	Y stroke										
	250	350	450	550	650	750	850	950	1050	1250	
L	667	767	867	967	1067	1167	1267	1367	1467	1567	1667
K	100	200	100	200	100	200	100	200	100	200	100
C	420	420	600	600	780	708	960	960	1140	1320	1320
M	2	2	3	3	4	4	5	5	6	6	7
N	8	8	10	10	12	12	14	14	16	16	18
Y stroke	250	350	450	550	650	750	850	950	1050		

Maximum speed for each stroke (mm/sec) ^{Note 3}	X-axis		Y-axis		Speed setting	
	250-450	550-1250	250-450	550-1250	250-450	550-1250
	1200	960	600	480	80%	70%
		840		420	60%	50%
		720		360	50%	40%

Note 1. The moving range when returning to origin and the stop position when stopping by the mechanical stopper.
 Note 2. User cable extraction port.

Note 3. When the X-axis/Y-axis stroke is longer than 850mm, resonance of the ball screw may occur depending on the operation conditions (critical speed). In this case, reduce the speed setting on the program by referring to the maximum speeds shown in the table at the left.

HXYx 2 axes

● Pole type ● Whipover



Ordering method

HXYx - S - P1

Model	Cable	Combination	X-axis stroke ^{Note 1}	Y-axis stroke ^{Note 1}	Cable
			25 to 85cm	25 to 85cm	3L: 3.5m 5L: 5m 10L: 10m

RCX320-2	R					
Controller / Number of controllable axes	Safety standard	Regenerative unit	Option A (OP.A)	Option B (OP.B)	Vision System	Absolute battery

Specify various controller setting items. RCX320 ▶ **P548**

RCX222HP	R			
Controller	Usable for CE	Regenerative unit	I/O selection 1	I/O selection 2

Specify various controller setting items. RCX222 ▶ **P558**

Note 1. The total of the X and Y strokes should be 1100mm or less.

Specification

	X-axis	Y-axis
Axis construction ^{Note 1}	F20	F20-BK
AC servo motor output (W)	600	600
Repeatability ^{Note 2} (mm)	+/-0.01	+/-0.01
Drive system	Ball screw φ20	Ball screw φ20
Ball screw lead ^{Note 3} (Deceleration ratio) (mm)	20	10
Maximum speed ^{Note 4} (mm/sec)	1200	600
Moving range (mm)	250 to 850	250 to 850
Robot cable length (m)	Standard: 3.5 Option: 5, 10	

Note 1. Use caution that the flange machining (installation holes, tap holes) differs from single-axis robots.
 Note 2. Positioning repeatability in one direction.
 Note 3. Leads not listed in the catalog are also available. Contact us for details.
 Note 4. When the X-axis/Y-axis stroke is longer than 850mm, resonance of the ball screw may occur depending on the operation conditions (critical speed). In this case, reduce the speed setting on the program by referring to the maximum speeds shown in the table below.

Maximum payload (kg)

Y stroke (mm)	XY 2 axes
250 to 850	30

Controller

Controller	Operation method
RCX320-R RCX222HP-R	Programming / I/O point trace / Remote command / Operation using RS-232C communication

HXYx 2 axes P1

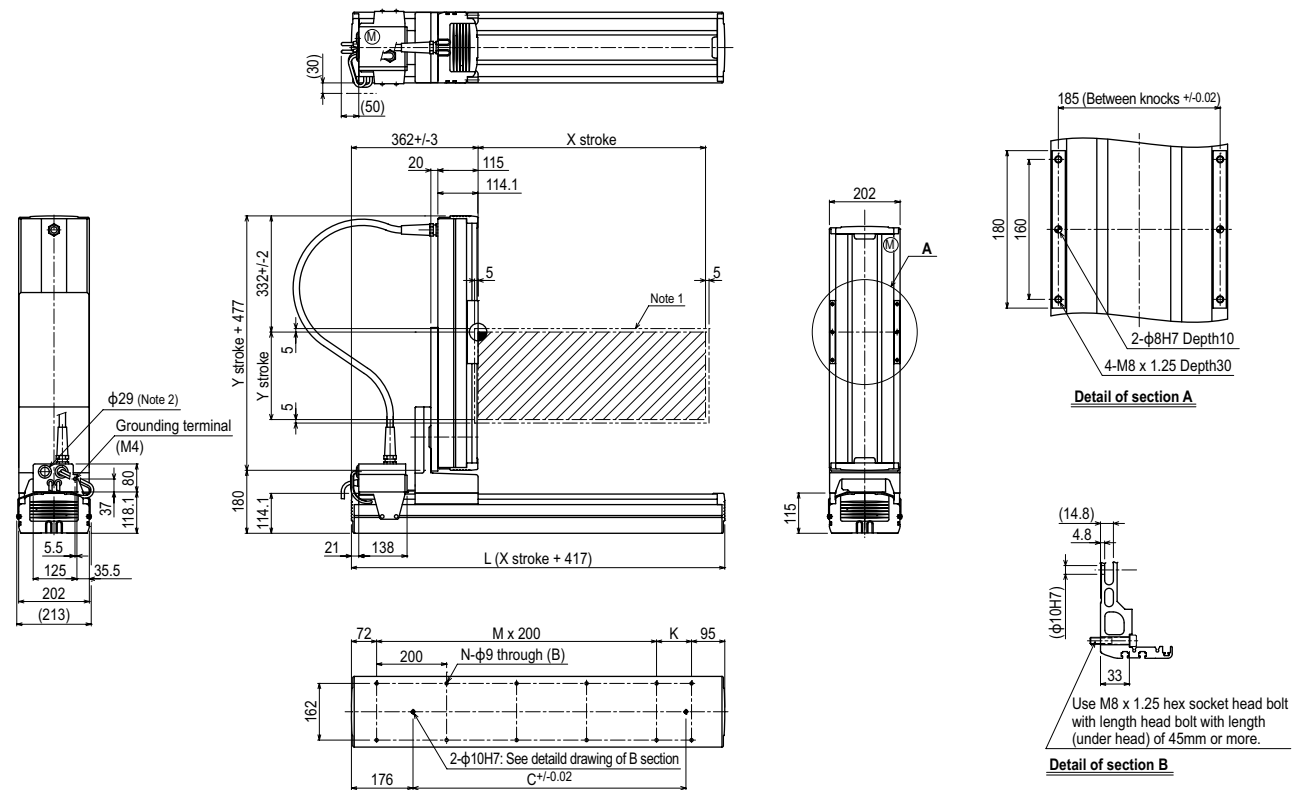

X stroke ^{Note 3}	250	350	450	550	650	750	850	
	L	667	767	867	967	1067	1167	1267
K	100	200	100	200	100	200	100	
C	420	420	600	600	780	780	960	
M	2	2	3	3	4	4	5	
N	8	8	10	10	12	12	14	
Y stroke ^{Note 3}	250	350	450	550	650	750	850	
Maximum speed for each stroke (mm/sec) ^{Note 4}	X-axis	1200					960	
	Y-axis	600					480	
	Speed setting	-					80%	

Note 1. The moving range when returning to origin and the stop position when stopping by the mechanical stopper.
 Note 2. User cable extraction port.

Note 3. The total of the X and Y strokes should be 1100mm or less.
 Note 4. When the X-axis/Y-axis stroke is longer than 850mm, resonance of the ball screw may occur depending on the operation conditions (critical speed). In this case, reduce the speed setting on the program by referring to the maximum speeds shown in the table at the left.

HXYx

3 axes / ZPH

- Pole type
- Cable carrier
- Z-axis: Clamped table / moving base type (200W) for Pole type

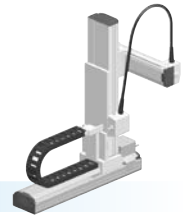

Ordering method

HXYx - C - P2 - [] - [] - [] - [] - **RCX340-3** - [] - [] - [] - [] - [] - []

Model	Cable	Combination	X-axis stroke ^{Note 1}	Y-axis stroke ^{Note 1}	ZR-axis	Z-axis stroke	Cable	Controller / Number of controllable axes	Safety standard	Option A (OP.A)	Option B (OP.B)	Option C (OP.C)	Option D (OP.D)	Option E (OP.E)	Absolute battery
			25 to 125cm	25 to 95cm	ZPHL ZPHR	25 to 65cm	3L: 3.5m 5L: 5m 10L: 10m								

Specify various controller setting items. RCX340 ▶ **P.566**

Note 1. The total of the Y and Z strokes should be 1200mm or less.

Specification

	X-axis	Y-axis	Z-axis
Axis construction ^{Note 1}	F20	F20-BK	F14H
AC servo motor output (W)	600	600	200
Repeatability ^{Note 2} (mm)	+/-0.01	+/-0.01	+/-0.01
Drive system	Ball screw φ20	Ball screw φ20	Ball screw φ15
Ball screw lead ^{Note 3} (Deceleration ratio) (mm)	20	10	20
Maximum speed ^{Note 4} (mm/sec)	1200	600	1200
Moving range (mm)	250 to 1250	250 to 950	250 to 650
Robot cable length (m)	Standard: 3.5 Option: 5,10		

Note 1. Use caution that the flame machining (installation holes, tap holes) differs from single-axis robots.
 Note 2. Positioning repeatability in one direction.
 Note 3. Leads not listed in the catalog are also available. Contact us for details.
 Note 4. When the X-axis/Y-axis stroke is longer than 850mm, resonance of the ball screw may occur depending on the operation conditions (critical speed). In this case, reduce the speed setting on the program by referring to the maximum speeds shown in the table below.

Maximum payload (kg)

Y stroke (mm)	Z stroke (mm)
250 to 950	15

Controller

Controller	Operation method
RCX340	Programming / I/O point trace / Remote command / Operation using RS-232C communication

HXYx 3 axes / ZPHL (P2)

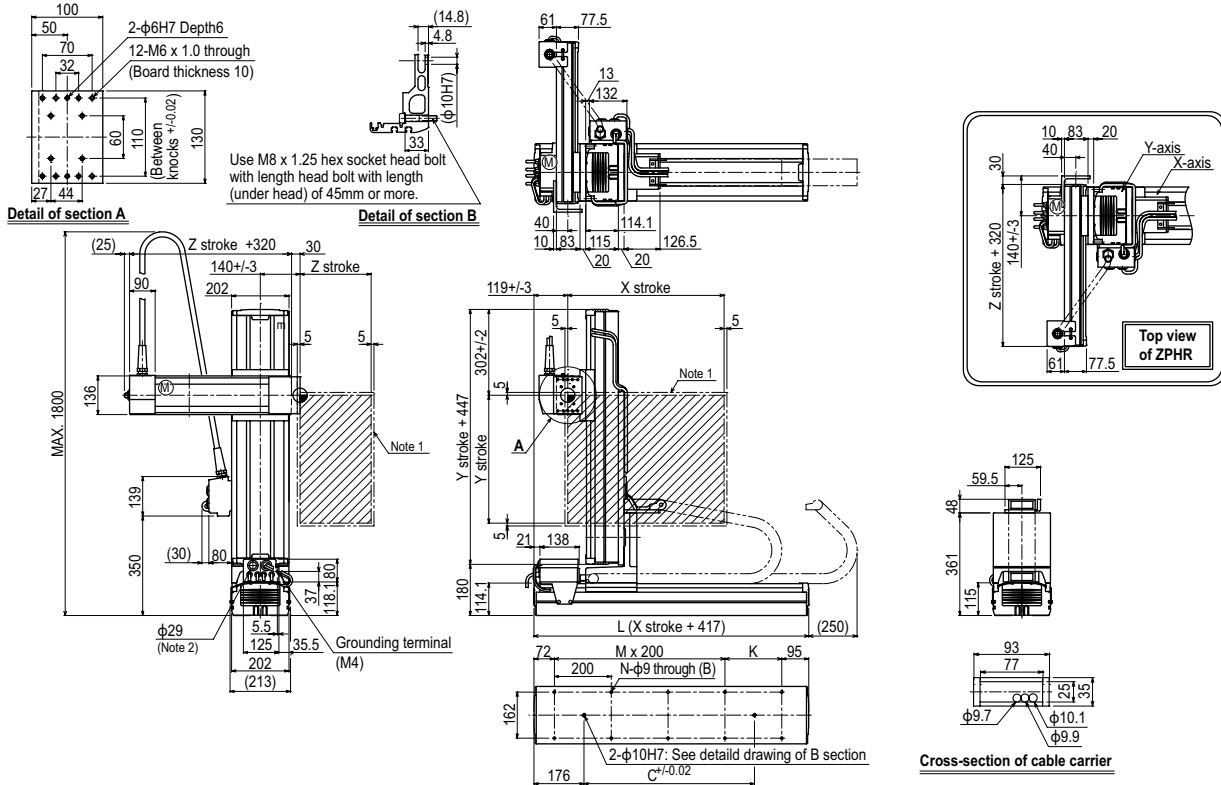

X stroke ^{Note 4}	250	350	450	550	650	750	850	950	1050	1150	1250	
	L	667	767	867	967	1067	1167	1267	1367	1467	1567	1667
K	100	200	100	200	100	200	100	200	100	200	100	
C	420	420	600	600	780	780	960	960	1140	1320	1320	
M	2	2	3	3	4	4	5	5	6	6	7	
N	8	8	10	10	12	12	14	14	16	16	18	
Y stroke ^{Note 4}	250	350	450	550	650	750	850	950				
Z stroke	250	350	450	550	650							
Maximum speed for each stroke (mm/sec) ^{Note 5}	X-axis	1200					960	840	720	600	480	
	Y-axis	600					480	420				
	Speed setting	-					80%	70%	60%	50%	40%	

Note 1. The moving range when returning to origin and the stop position when stopping by the mechanical stopper.
 Note 2. User cable extraction port.
 Note 3. This figure shows the combination for ZPHL. For the combination for ZPHR, see the top view in the figure.

Note 4. The total of the Y and Z strokes should be 1200mm or less.
 Note 5. When the X-axis/Y-axis stroke is longer than 850mm, resonance of the ball screw may occur depending on the operation conditions (critical speed). In this case, reduce the speed setting on the program by referring to the maximum speeds shown in the table at the left.



Ordering method

HXYx - S - P1 [] [] [] [] [] **RCX340-3** [] [] [] [] [] [] [] []

Model	Cable	Combination	X-axis stroke^{Note 1}	Y-axis stroke^{Note 1}	ZR-axis	Z-axis stroke	Cable	Controller / Number of controllable axes	Safety standard	Option A (OP.A)	Option B (OP.B)	Option C (OP.C)	Option D (OP.D)	Option E (OP.E)	Absolute battery
			25 to 85cm	25 to 85cm	ZPHL ZPHR	25 to 65cm	3L: 3.5m 5L: 5m 10L: 10m	RCX340							

Specify various controller setting items. RCX340 ▶ **P.566**

Note 1. The total of the X and Y strokes should be 1100mm or less and that of the Y and Z strokes should be 1200mm or less.

Specification

	X-axis	Y-axis	Z-axis
Axis construction ^{Note 1}	F20	F20-BK	F14H
AC servo motor output (W)	600	600	200
Repeatability ^{Note 2} (mm)	+/-0.01	+/-0.01	+/-0.01
Drive system	Ball screw φ20	Ball screw φ20	Ball screw φ15
Ball screw lead ^{Note 3} (Deceleration ratio) (mm)	20	10	20
Maximum speed ^{Note 4} (mm/sec)	1200	600	1200
Moving range (mm)	250 to 850	250 to 850	250 to 650
Robot cable length (m)	Standard: 3.5 Option: 5,10		

Note 1. Use caution that the flame machining (installation holes, tap holes) differs from single-axis robots.

Note 2. Positioning repeatability in one direction.

Note 3. Leads not listed in the catalog are also available. Contact us for details.

Note 4. When the X-axis/Y-axis stroke is longer than 850mm, resonance of the ball screw may occur depending on the operation conditions (critical speed). In this case, reduce the speed setting on the program by referring to the maximum speeds shown in the table below.

Maximum payload (kg)

Y stroke (mm)	Z stroke (mm)
250 to 850	15

Controller

Controller	Operation method
RCX340	Programming / I/O point trace / Remote command / Operation using RS-232C communication

HXYx 3 axes / ZPHL (P1)

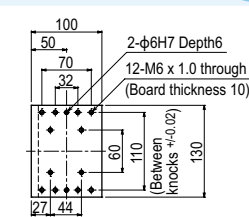

Detail of section A

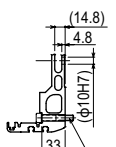

Use M8 x 1.25 hex socket head bolt with length head bolt with length (under head) of 45mm or more.

Detail of section B

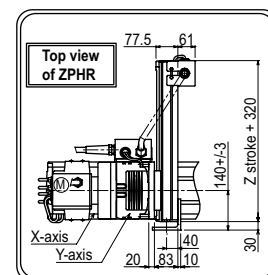
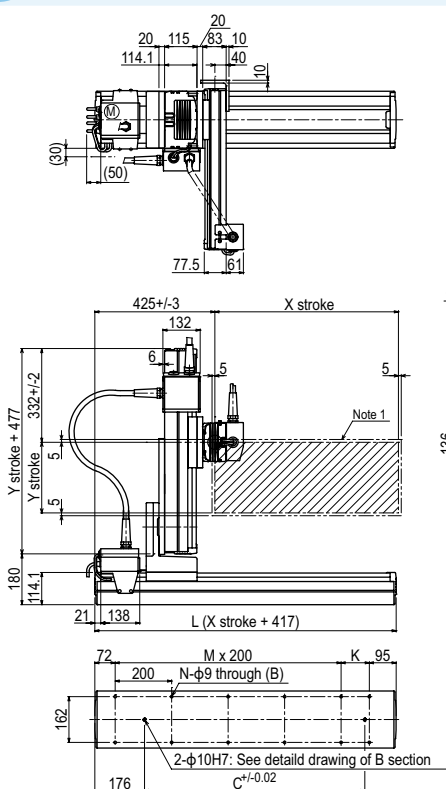
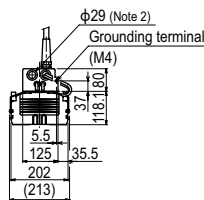

X stroke ^{Note 4}	250	350	450	550	650	750	850
L	667	767	867	967	1067	1167	1267
K	100	200	100	200	100	200	100
D	420	420	600	600	780	780	960
M	2	2	3	3	4	4	5
N	8	8	10	10	12	12	14

Y stroke ^{Note 4}	250	350	450	550	650	750	850
Z stroke	250	350	450	550	650		

Maximum speed for each stroke (mm/sec) ^{Note 5}	X-axis	1200	960
	Y-axis	600	480
Speed setting		-	80%

Note 1. The moving range when returning to origin and the stop position when stopping by the mechanical stopper.

Note 2. User cable extraction port.

Note 3. This figure shows the combination for ZPHL. For the combination for ZPHR, see the top view in the figure.

Note 4. The total of the X and Y strokes should be 1100mm or less and that of the Y and Z strokes should be 1200mm or less.

Note 5. When the X-axis/Y-axis stroke is longer than 850mm, resonance of the ball screw may occur depending on the operation conditions (critical speed). In this case, reduce the speed setting on the program by referring to the maximum speeds shown in the table at the left.

Articulated robots
YA
Linear conveyor modules
LCM100
Motorless single axis robot
Robonity
Compact single-axis robots
TRANSEVO
Single-axis robots
FLIP-X
Linear motor single-axis robots
PHASER
Cartesian robots
XY-X
SCARA robots
YK-X
Pick & place robots
YP-X
CLEAN
CONTROLLER INFORMATION
Arm type
Gantry type
Moving arm type
Pole type
XZ type

SXYx 2 axes / ZF

● XZ type ● Cable carrier ● Z-axis: clamped base / moving table type (100W)



Ordering method

SXYx - C [] [] **ZF** [] [] [] [] [] []

Model [] **Cable** [] **Combination** [] **X-axis stroke** [] **ZR-axis** [] **Z-axis stroke** [] **Cable** []

RCX320-2 [] [] [] [] [] []

RCX222 [] [] [] [] [] []

Specify various controller setting items. RCX320 ▶ P.548
Specify various controller setting items. RCX222 ▶ P.558

Specification

	X-axis	Z-axis
Axis construction <small>Note 1</small>	F14	F10-BK
AC servo motor output (W)	100	100
Repeatability <small>Note 2</small> (mm)	+/-0.01	+/-0.01
Drive system	Ball screw φ15	Ball screw φ15
Ball screw lead <small>Note 3</small> (Deceleration ratio) (mm)	20	10
Maximum speed <small>Note 4</small> (mm/sec)	1200	600
Moving range (mm)	150 to 1050	150 to 350
Robot cable length (m)	Standard: 3.5 Option: 5,10	

Note 1. Use caution that the frame machining (installation holes, tap holes) differs from single-axis robots.
 Note 2. Positioning repeatability in one direction.
 Note 3. Leads not listed in the catalog are also available. Contact us for details.
 Note 4. When the X-axis stroke is longer than 750mm, resonance of the ball screw may occur depending on the operation conditions (critical speed). In this case, reduce the speed setting on the program by referring to the maximum speeds shown in the table below.

Maximum payload (kg)

X stroke (mm)	Z stroke (mm)
150 to 1050	150 to 350
	10

Controller

Controller	Operation method
RCX320	Programming / I/O point trace / Remote command / Operation using RS-232C communication
RCX222	

SXYx 2 axes / ZF (F1)

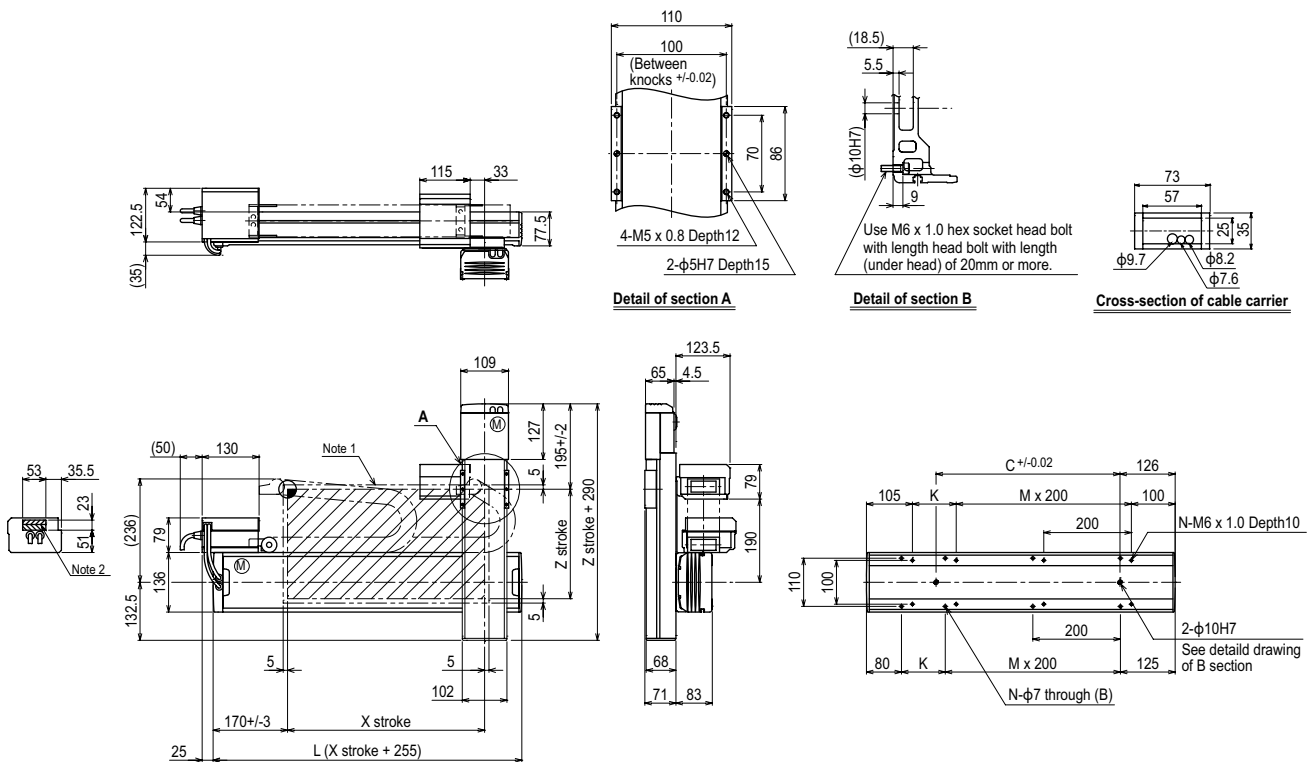

X stroke	150	250	350	450	550	650	750	850	950	1050
L	405	505	605	705	805	905	1005	1105	1205	1305
K	200	100	200	100	200	100	200	100	200	100
C	240	240	420	420	600	600	780	780	960	960
M	0	1	1	2	2	3	3	4	4	5
N	4	6	6	8	8	10	10	12	12	14
Z stroke	150	250	350							
Maximum speed for each stroke (mm/sec) <small>Note 3</small>	X-axis		1200				960	780	600	540
Speed setting			-				80%	65%	50%	45%

Note 1. The moving range when returning to origin and the stop position when stopping by the mechanical stopper.
 Note 2. The shaded position indicates a user cable extraction port.

Note 3. When the X-axis stroke is longer than 750mm, resonance of the ball screw may occur depending on the operation conditions (critical speed). In this case, reduce the speed setting on the program by referring to the maximum speeds shown in the table at the left.

SXYx 2 axes / ZF

XZ type
 Whipover
 Z-axis: clamped base / moving table type (100W)

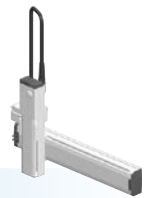

Ordering method

SXYx - S [] [] **ZF** [] [] []

Model	Cable	Combination	X-axis stroke	ZR-axis	Z-axis stroke	Cable
F1			15 to 85cm		15 to 35cm	3L: 3.5m 5L: 5m 10L: 10m
F3						

RCX320-2 [] [] [] [] [] []

Controller / Number of controllable axes Safety standard Option A (OP.A) Option B (OP.B) Vision System Absolute battery

Specify various controller setting items. RCX320 ▶ **P.548**

RCX222 [] [] [] []

Controller Usable for CE I/O selection 1 I/O selection 2

Specify various controller setting items. RCX222 ▶ **P.558**

Specification

	X-axis	Z-axis
Axis construction ^{Note 1}	F14	F10-BK
AC servo motor output (W)	100	100
Repeatability ^{Note 2} (mm)	+/-0.01	+/-0.01
Drive system	Ball screw φ15	Ball screw φ15
Ball screw lead ^{Note 3} (Deceleration ratio) (mm)	20	10
Maximum speed ^{Note 4} (mm/sec)	1200	600
Moving range (mm)	150 to 850	150 to 350
Robot cable length (m)	Standard: 3.5 Option: 5,10	

Note 1. Use caution that the flange machining (installation holes, tap holes) differs from single-axis robots.
 Note 2. Positioning repeatability in one direction.
 Note 3. Leads not listed in the catalog are also available. Contact us for details.
 Note 4. When the X-axis stroke is longer than 750mm, resonance of the ball screw may occur depending on the operation conditions (critical speed). In this case, reduce the speed setting on the program by referring to the maximum speeds shown in the table below.

Maximum payload (kg)

X stroke (mm)	Z stroke (mm)
150 to 850	150 to 350
	10

Controller

Controller	Operation method
RCX320	Programming / I/O point trace / Remote command / Operation using RS-232C communication
RCX222	

SXYx 2 axes / ZF (F1)

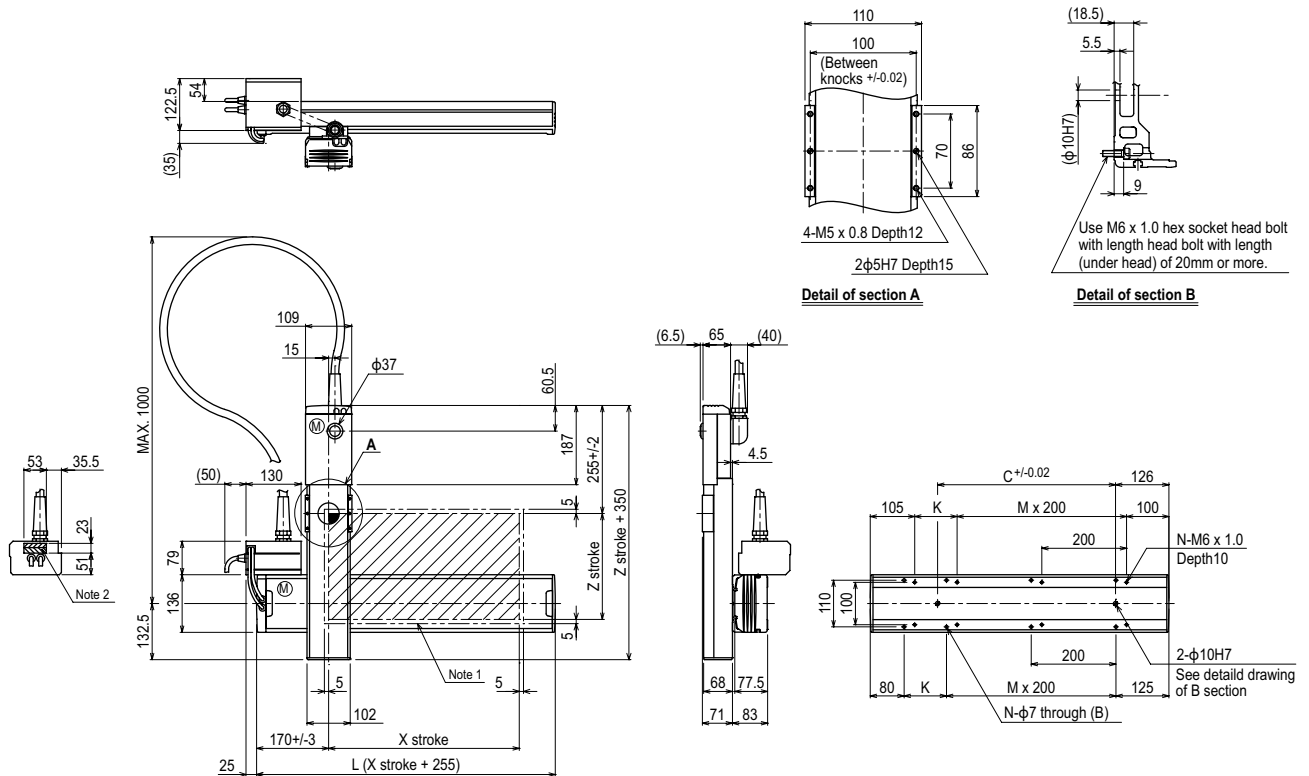

X stroke	150	250	350	450	550	650	750	850
L	405	505	605	705	805	905	1005	1105
K	200	100	200	100	200	100	200	100
C	240	240	420	420	600	600	780	780
M	0	1	1	2	2	3	3	4
N	4	6	6	8	8	10	10	12
Z stroke	150	250	350					
Maximum speed for each stroke (mm/sec) ^{Note 3}	X-axis		1200			960		780
Speed setting			-			80%		65%

Note 1. The moving range when returning to origin and the stop position when stopping by the mechanical stopper.
 Note 2. The shaded position indicates a user cable extraction port.

Note 3. When the X-axis stroke is longer than 750mm, resonance of the ball screw may occur depending on the operation conditions (critical speed). In this case, reduce the speed setting on the program by referring to the maximum speeds shown in the table at the left.

Articulated robots
YA
Linear conveyor modules
LCM100
Motor-less single axis actuator
Robonity
Compact single-axis robots
TRANSEVO
Single-axis robots
FLIP-X
Linear motor single-axis robots
PHASER
Cartesian robots
XY-X
SCARA robots
YK-X
Pick & place robots
YP-X
CLEAN
CONTROLLER INFORMATION
Arm type
Gantry type
Moving arm type
Pole type
XZ type

SXYx 2 axes / ZFL20

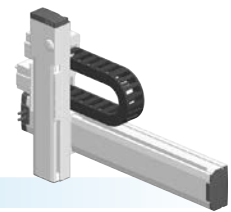

● XZ type ● Cable carrier ● Z-axis: clamped base / moving table type (200W)

Ordering method

SXYx - C **ZFL20** **RCX320-2** **R**

Model	Cable	Combination	X-axis stroke	ZR-axis	Z-axis stroke	Cable	Controller / Number of controllable axes	Safety standard	Regenerative unit	Option A (OP.A)	Option B (OP.B)	Vision System	Absolute battery
F1			15 to 105cm		15 to 35cm	3L: 3.5m 5L: 5m 10L: 10m	RCX320-2						

Specify various controller setting items. RCX320 ▶ **P.548**

Controller	Usable for CE	Regenerative unit	I/O selection 1	I/O selection 2
RCX222				

Specify various controller setting items. RCX222 ▶ **P.558**

Note 1. RCX320 uses the YHX-RU regenerative unit. The RCX222 uses the RG2.

Specification

	X-axis	Z-axis
Axis construction ^{Note 1}	F14	F10H-BK
AC servo motor output (W)	100	200
Repeatability ^{Note 2} (mm)	+/-0.01	+/-0.01
Drive system	Ball screw φ15	Ball screw φ15
Ball screw lead ^{Note 3} (Deceleration ratio) (mm)	20	20
Maximum speed ^{Note 4} (mm/sec)	1200	1200
Moving range (mm)	150 to 1050	150 to 350
Robot cable length (m)	Standard: 3.5 Option: 5,10	

Note 1. Use caution that the flame machining (installation holes, tap holes) differs from single-axis robots.
 Note 2. Positioning repeatability in one direction.
 Note 3. Leads not listed in the catalog are also available. Contact us for details.
 Note 4. When the X-axis stroke is longer than 750mm, resonance of the ball screw may occur depending on the operation conditions (critical speed). In this case, reduce the speed setting on the program by referring to the maximum speeds shown in the table below.

Maximum payload (kg)

X stroke (mm)	Z stroke (mm)
150 to 1050	150 to 350
	8

Controller

Controller	Operation method
RCX320-R RCX222-R	Programming / I/O point trace / Remote command / Operation using RS-232C communication

SXYx 2 axes / ZFL20 (F1)

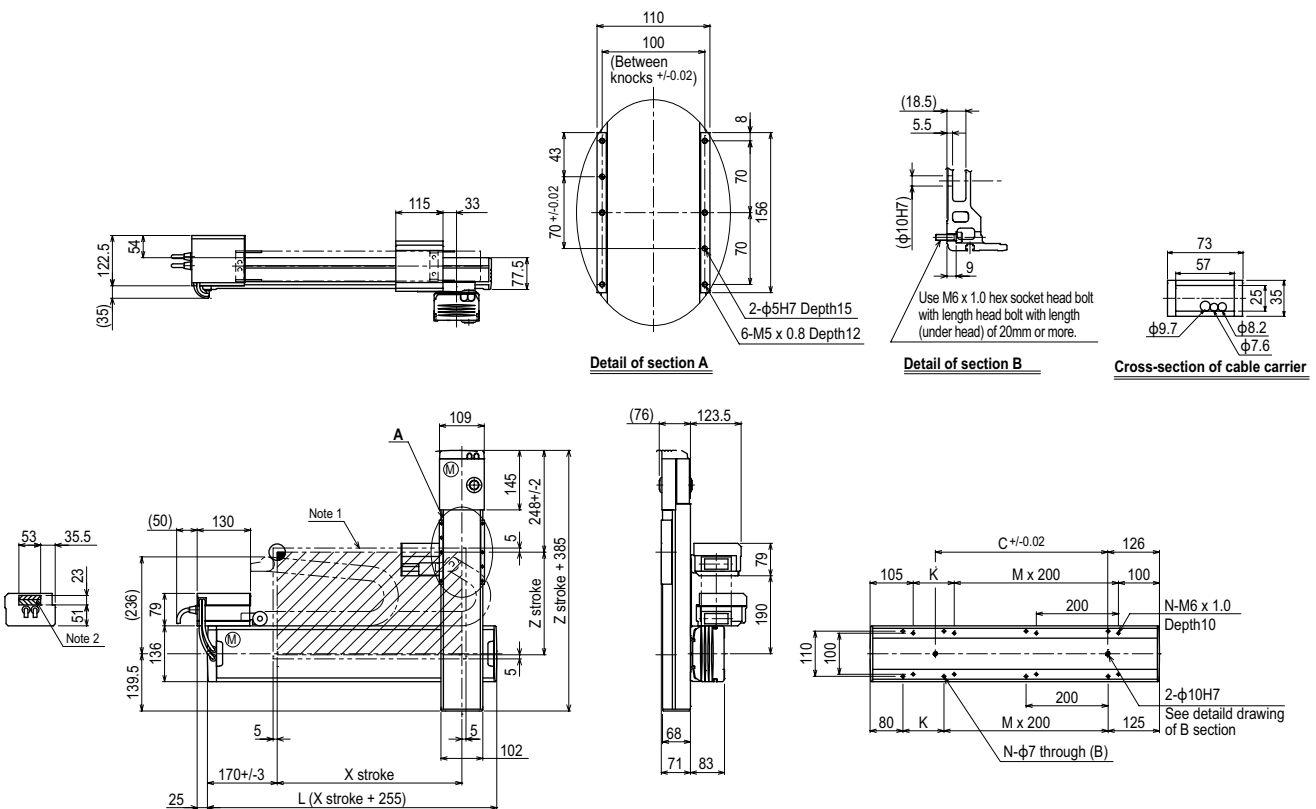

X stroke	150	250	350	450	550	650	750	850	950	1050				
L	405	505	605	705	805	905	1005	1105	1205	1305				
K	200	100	200	100	200	100	200	100	200	100				
C	240	240	420	420	600	600	780	780	960	960				
M	0	1	1	2	2	3	3	4	4	5				
N	4	6	6	8	8	10	10	12	12	14				
Z stroke	150	250	350											
Maximum speed for each stroke (mm/sec)	X-axis		1200				960		780		600		540	
Speed setting			-				80%		65%		50%		45%	

Note 1. The moving range when returning to origin and the stop position when stopping by the mechanical stopper.
 Note 2. The shaded position indicates a user cable extraction port.

Note 3. When the X-axis stroke is longer than 750mm, resonance of the ball screw may occur depending on the operation conditions (critical speed). In this case, reduce the speed setting on the program by referring to the maximum speeds shown in the table at the left.

SXYx 2 axes / ZS

- XZ type
- Cable carrier
- Z-axis shaft vertical type

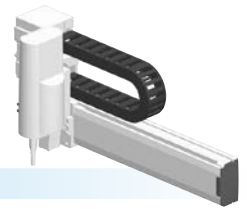

Ordering method

SXYx - C [] [] [] **15** []

Model	Cable	Combination	X-axis stroke	ZR-axis	Z-axis stroke	Cable
F1			15 to 105cm	ZS12		3L: 3.5m
F3				ZS6		5L: 5m
						10L: 10m

RCX320-2 [] [] [] [] [] []

Controller / Number of controllable axes	Safety standard	Option A (OP.A)	Option B (OP.B)	Vision System	Absolute battery
--	-----------------	-----------------	-----------------	---------------	------------------

Specify various controller setting items. RCX320 ▶ **P548**

RCX222 [] [] [] [] [] []

Controller	Usable for CE	I/O selection 1	I/O selection 2
------------	---------------	-----------------	-----------------

Specify various controller setting items. RCX222 ▶ **P558**

Specification

	X-axis	Z-axis: ZS12	Z-axis: ZS6
Axis construction ^{Note 1}	F14	-	
AC servo motor output (W)	100	60	
Repeatability ^{Note 2} (mm)	+/-0.01	+/-0.02	
Drive system	Ball screw φ15	Ball screw φ12	
Ball screw lead ^{Note 3} (Deceleration ratio) (mm)	20	12	6
Maximum speed ^{Note 4} (mm/sec)	1200	1000	500
Moving range (mm)	150 to 1050	150	
Robot cable length (m)	Standard: 3.5 Option: 5, 10		

- Note 1. Use caution that the flange machining (installation holes, tap holes) differs from single-axis robots.
 Note 2. Positioning repeatability in one direction.
 Note 3. Leads not listed in the catalog are also available. Contact us for details.
 Note 4. When the X-axis stroke is longer than 750mm, resonance of the ball screw may occur depending on the operation conditions (critical speed). In this case, reduce the speed setting on the program by referring to the maximum speeds shown in the table below.

Maximum payload (kg)

Y stroke (mm)	ZS12	ZS6
150 to 1050	3	5

Controller

Controller	Operation method
RCX320	Programming / I/O point trace / Remote command / Operation using RS-232C communication
RCX222	

SXYx 2 axes / ZS (F1)

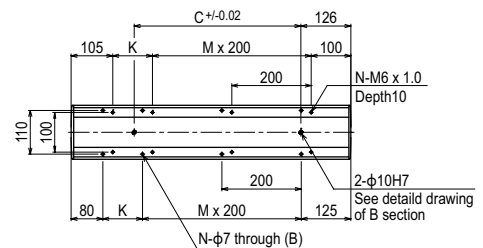
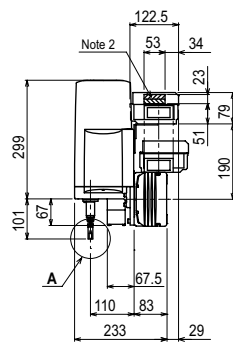
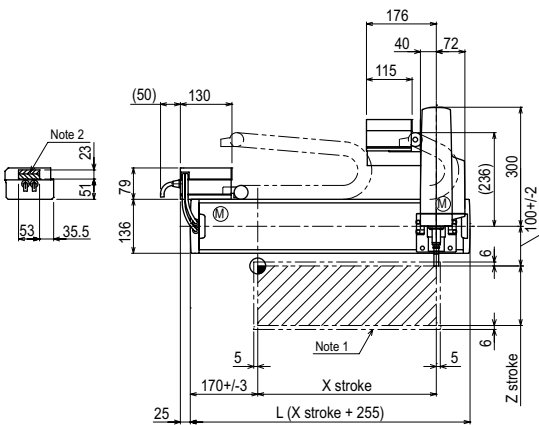
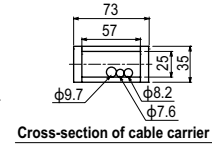
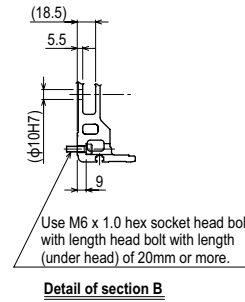
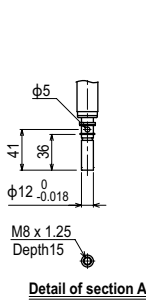
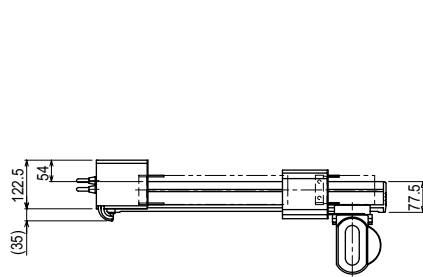

X stroke	150	250	350	450	550	650	750	850	950	1050	
L	405	505	605	705	805	905	1005	1105	1205	1305	
K	200	100	200	100	200	100	200	100	200	100	
C	240	240	420	420	600	600	780	780	960	960	
M	0	1	1	2	2	3	3	4	4	5	
N	4	6	6	8	8	10	10	12	12	14	
Z stroke	150										
Maximum speed for each stroke (mm/sec) ^{Note 3}	X-axis	1200					960	780	600	540	
Speed setting		-					80%	65%	50%	45%	

- Note 1. The moving range when returning to origin and the stop position when stopping by the mechanical stopper.
 Note 2. The shaded position indicates an user cable extraction port.

- Note 3. When the X-axis stroke is longer than 750mm, resonance of the ball screw may occur depending on the operation conditions (critical speed). In this case, reduce the speed setting on the program by referring to the maximum speeds shown in the table at the left.

Articulated robots
YA
Linear conveyor modules
LCM100
Motor-less single axis actuator
Robonity
Compact single-axis robots
TRANSEVO
Single-axis robots
FLIP-X
Linear motor single-axis robots
PHASER
Cartesian robots
XY-X
SCARA robots
YK-X
Pick & place robots
YP-X
CLEAN
CONTROLLER INFORMATION
Arm type
Gantry type
Moving arm type
Pole type
XZ type

SXYBx

2 axes / ZF

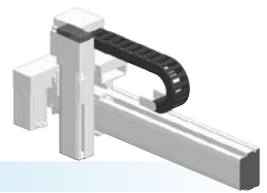

- XZ type
- Cable carrier
- Z-axis: clamped base / moving table type (100W)

Ordering method

SXYBx - C [] [] **ZF** [] [] []

Model	Cable	Combination	X-axis stroke	ZR-axis	Z-axis stroke	Cable
F1			15 to 305cm		15 to 35cm	3L: 3.5m 5L: 5m 10L: 10m

RCX320-2 [] [] [] [] [] []

Controller / Number of controllable axes	Safety standard	Regenerative unit	Option A (OP.A)	Option B (OP.B)	Vision System	Absolute battery
--	-----------------	-------------------	-----------------	-----------------	---------------	------------------

Specify various controller setting items. RCX320 ▶ **P548**

RCX222 [] [] [] [] [] []

Controller	Usable for CE	Regenerative unit	I/O selection 1	I/O selection 2
------------	---------------	-------------------	-----------------	-----------------

Specify various controller setting items. RCX222 ▶ **P558**

Note 1. A regenerative unit is required when the maximum speed exceeds 1250mm/sec.

Specification

	X-axis	Z-axis
Axis construction ^{Note 1}	B14H	F10-BK
AC servo motor output (W)	200	100
Repeatability ^{Note 2} (mm)	+/-0.04	+/-0.01
Drive system	Timing belt	Ball screw φ15
Ball screw lead ^{Note 3} (Deceleration ratio) (mm)	Equivalent to lead 25	10
Maximum speed (mm/sec)	1875	600
Moving range (mm)	150 to 3050	150 to 350
Robot cable length (m)	Standard: 3.5 Option: 5,10	

Note 1. Use caution that the flange machining (installation holes, tap holes) differs from single-axis robots.
 Note 2. Positioning repeatability in one direction.
 Note 3. Leads not listed in the catalog are also available. Contact us for details.

Maximum payload (kg)

X stroke (mm)	Z stroke (mm)
150 to 3050	150 to 350
	10

Controller

Controller	Operation method
RCX320	Programming / I/O point trace / Remote command / Operation using RS-232C communication
RCX222	

Note. A regenerative unit is required when the maximum speed exceeds 1250mm/sec.

SXYBx 2 axes / ZF (F1)

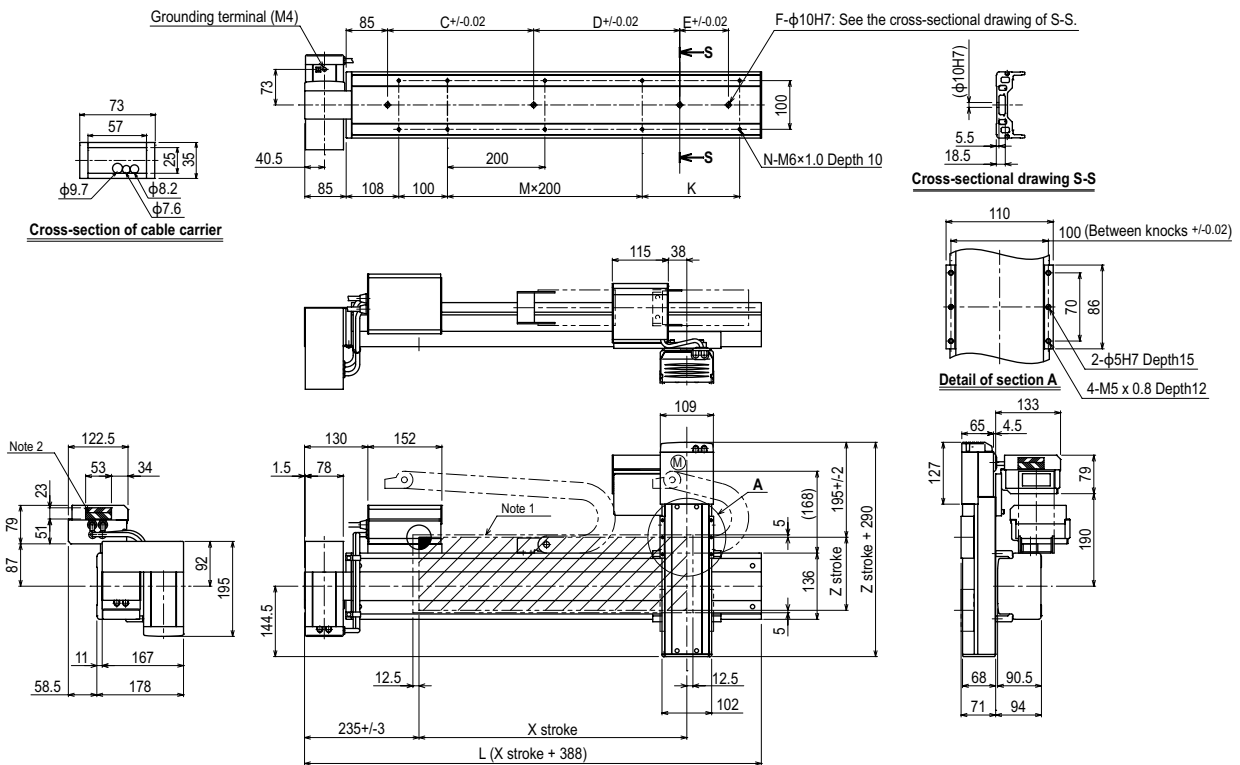

Note 1. The moving range when returning to origin and the stop position when stopping by the mechanical stopper.
 Note 2. The shaded position indicates a user cable extraction port.
 Note 3. LU specification should be used for installation of the X axis motor.

X stroke	150	250	350	450	550	650	750	850	950	1050	1150	1250	1350	1450	1550	1650	1750	1850	1950	2050	2150	2250	2350	2450	2550	2650	2750	2850	2950	3050	
L	538	638	738	838	938	1038	1138	1238	1338	1438	1538	1638	1738	1838	1938	2038	2138	2238	2338	2438	2538	2638	2738	2838	2938	3038	3138	3238	3338	3438	
K	-	100	200	100	200	100	200	100	200	100	200	100	200	100	200	100	200	100	200	100	200	100	200	100	200	100	200	100	200	100	200
C	240	420	420	600	600	780	780	960	1140	1140	1140	1140	1140	1140	1140	1140	1140	1140	1140	1140	1140	1140	1140	1140	1140	1140	1140	1140	1140	1140	1140
D	-	-	-	-	-	-	-	-	-	-	-	240	240	420	600	600	780	780	960	960	1140	1140	1140	1140	1140	1140	1140	1140	1140	1140	1140
E	-	-	-	-	-	-	-	-	-	-	-	-	-	-	-	-	-	-	-	-	-	-	240	240	420	420	600	600	780	960	
F	2	2	2	2	2	2	2	2	2	2	2	3	3	3	3	3	3	3	3	3	3	3	3	4	4	4	4	4	4	4	4
M	1	1	1	2	2	3	3	4	4	5	5	6	6	7	7	8	8	9	9	10	10	11	11	12	12	13	13	14	14	15	
N	6	8	8	10	10	12	12	14	14	16	16	18	18	20	20	22	22	24	24	26	26	28	28	30	30	32	32	34	34	36	
Z stroke	150	250	350																												

SXYBx

2 axes / ZFL20

- XZ type
- Cable carrier
- Z-axis: clamped base / moving table type (200W)

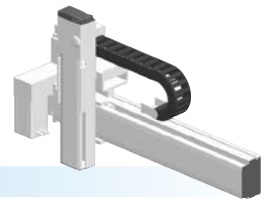

Ordering method

SXYBx - C [] [] **ZFL20** [] [] **RCX320-2** [] **R** [] [] [] [] [] []

Model Cable Combination X-axis stroke ZR-axis Z-axis stroke Cable

F1 15 to 305cm 3L: 3.5m
F3 15 to 35cm 5L: 5m
10L: 10m

Controller / Number of controllable axes Safety standard Regenerative unit Option A (OP.A) Option B (OP.B) Vision System Absolute battery

Specify various controller setting items. RCX320 ▶ **P.548**

RCX222 [] **R** [] [] [] [] []

Controller Usable for CE Regenerative unit I/O selection 1 I/O selection 2

Specify various controller setting items. RCX222 ▶ **P.558**

Specification

	X-axis	Z-axis
Axis construction ^{Note 1}	B14H	F10H-BK
AC servo motor output (W)	200	200
Repeatability ^{Note 2} (mm)	+/-0.04	+/-0.01
Drive system	Timing belt	Ball screw φ15
Ball screw lead ^{Note 3} (Deceleration ratio) (mm)	Equivalent to lead 25	20
Maximum speed (mm/sec)	1875	1200
Moving range (mm)	150 to 3050	150 to 350
Robot cable length (m)	Standard: 3.5 Option: 5, 10	

Note 1. Use caution that the flange machining (installation holes, tap holes) differs from single-axis robots.
 Note 2. Positioning repeatability in one direction.
 Note 3. Leads not listed in the catalog are also available. Contact us for details.

Maximum payload (kg)

X stroke (mm)	Z stroke (mm)
150 to 3050	150 to 350
	8

Controller

Controller	Operation method
RCX320-R RCX222-R	Programming / I/O point trace / Remote command / Operation using RS-232C communication

SXYBx 2 axes / ZFL20 (F1)

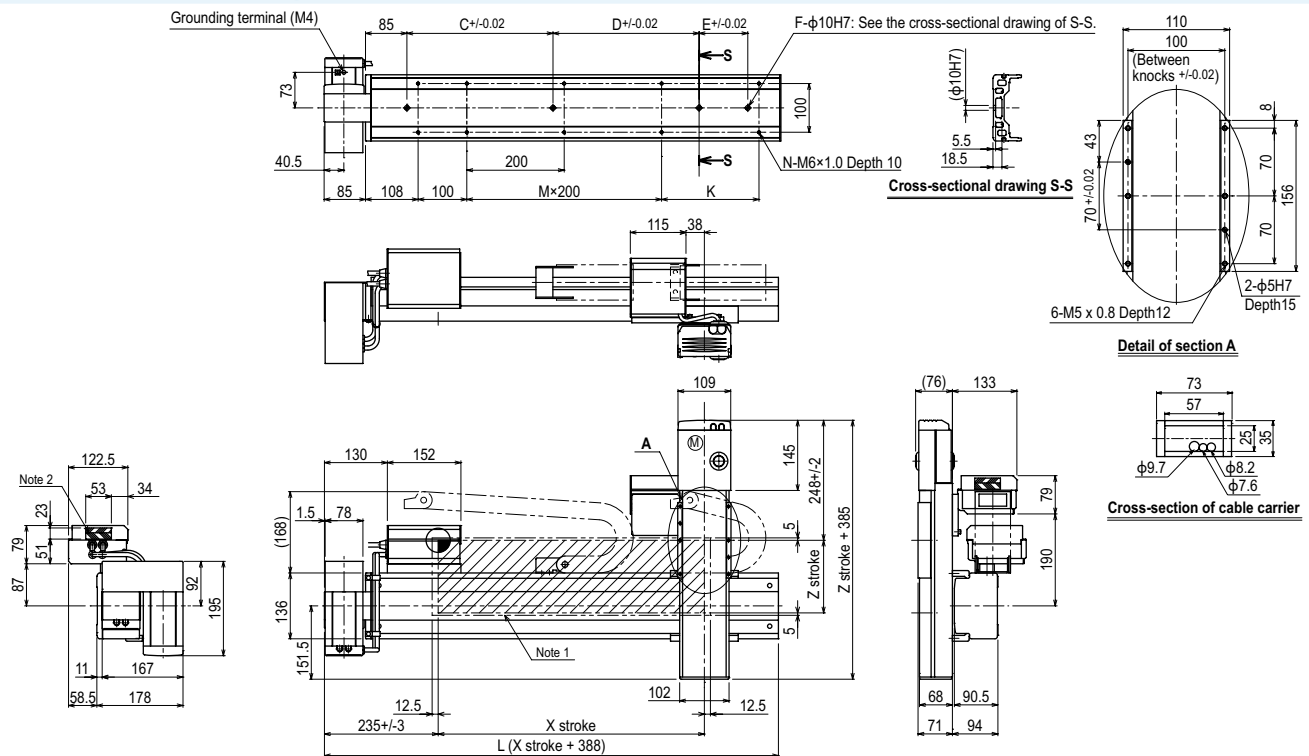

Note 1. The moving range when returning to origin and the stop position when stopping by the mechanical stopper.
 Note 2. The shaded position indicates an user cable extraction port.
 Note 3. LU specification should be used for installation of the X axis motor.

X stroke	150	250	350	450	550	650	750	850	950	1050	1150	1250	1350	1450	1550	1650	1750	1850	1950	2050	2150	2250	2350	2450	2550	2650	2750	2850	2950	3050		
L	538	638	738	838	938	1038	1138	1238	1338	1438	1538	1638	1738	1838	1938	2038	2138	2238	2338	2438	2538	2638	2738	2838	2938	3038	3138	3238	3338	3438		
K	-	100	200	100	200	100	200	100	200	100	200	100	200	100	200	100	200	100	200	100	200	100	200	100	200	100	200	100	200	100	200	
C	240	420	420	600	600	780	780	960	1140	1140	1140	1140	1140	1140	1140	1140	1140	1140	1140	1140	1140	1140	1140	1140	1140	1140	1140	1140	1140	1140	1140	1140
D	-	-	-	-	-	-	-	-	-	-	-	-	-	-	-	-	-	-	-	-	-	-	-	-	-	-	-	-	-	-	-	-
E	-	-	-	-	-	-	-	-	-	-	-	-	-	-	-	-	-	-	-	-	-	-	-	-	-	-	-	-	-	-	-	-
F	2	2	2	2	2	2	2	2	2	2	2	3	3	3	3	3	3	3	3	3	3	3	3	3	3	3	3	3	3	3	3	3
M	1	1	1	2	2	3	3	4	4	5	5	6	6	7	7	8	8	9	9	10	10	11	11	12	12	13	13	14	14	15	15	
N	6	8	8	10	10	12	12	14	14	16	16	18	18	20	20	22	22	24	24	26	26	28	28	30	30	32	32	34	34	36	36	
Z stroke	150	250	350																													

Articulated robots
YA
Linear conveyor modules
LCM100
Motorized single axis actuator
Robonity
Compact single-axis robots
TRANSEVO
Single-axis robots
FLIP-X
Linear motor single-axis robots
PHASER
Cartesian robots
XY-X
SCARA robots
YK-X
Pick & place robots
YP-X
CLEAN
CONTROLLER INFORMATION
Arm type
Gantry type
Moving arm type
Pole type
XZ type

MXYx

2 axes / ZFL10

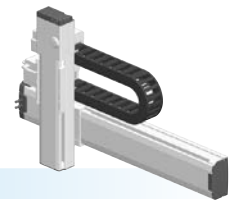

- XZ type
- Cable carrier
- Z-axis: clamped base / moving table type (200W)

Ordering method

MXYx - C [] [] **ZFL10** [] [] **RCX320-2** [] **R** [] [] [] [] [] []

Model	Cable	Combination	X-axis stroke	ZR-axis	Z-axis stroke	Cable
F1			15 to 105cm		15 to 35cm	3L: 3.5m 5L: 5m 10L: 10m
F3						

Controller / Number of controllable axes: RCX320-2
Safety standard: []
Regenerative unit: R
Option A (OP.A): []
Option B (OP.B): []
Vision System: []
Absolute battery: []

Specify various controller setting items. RCX320 ▶ P.548

RCX222 [] **R** [] [] [] [] []

Controller	Usable for CE	Regenerative unit	I/O selection 1	I/O selection 2
RCX222	[]	[]	[]	[]

Specify various controller setting items. RCX222 ▶ P.558

Specification

	X-axis	Z-axis
Axis construction ^{Note 1}	F14H	F10H-BK
AC servo motor output (W)	200	200
Repeatability ^{Note 2} (mm)	+/-0.01	+/-0.01
Drive system	Ball screw φ15	Ball screw φ15
Ball screw lead ^{Note 3} (Deceleration ratio) (mm)	20	10
Maximum speed ^{Note 4} (mm/sec)	1200	600
Moving range (mm)	150 to 1050	150 to 350
Robot cable length (m)	Standard: 3.5 Option: 5, 10	

- Note 1. Use caution that the flange machining (installation holes, tap holes) differs from single-axis robots.
 Note 2. Positioning repeatability in one direction.
 Note 3. Leads not listed in the catalog are also available. Contact us for details.
 Note 4. When the X-axis stroke is longer than 750mm, resonance of the ball screw may occur depending on the operation conditions (critical speed). In this case, reduce the speed setting on the program by referring to the maximum speeds shown in the table below.

Maximum payload (kg)

X stroke (mm)	Z stroke (mm)
150 to 1050	150 to 350
	15

Controller

Controller	Operation method
RCX320-R	Programming / I/O point trace / Remote command / Operation using RS-232C communication
RCX222-R	

MXYx 2 axes / ZFL10 (F1)

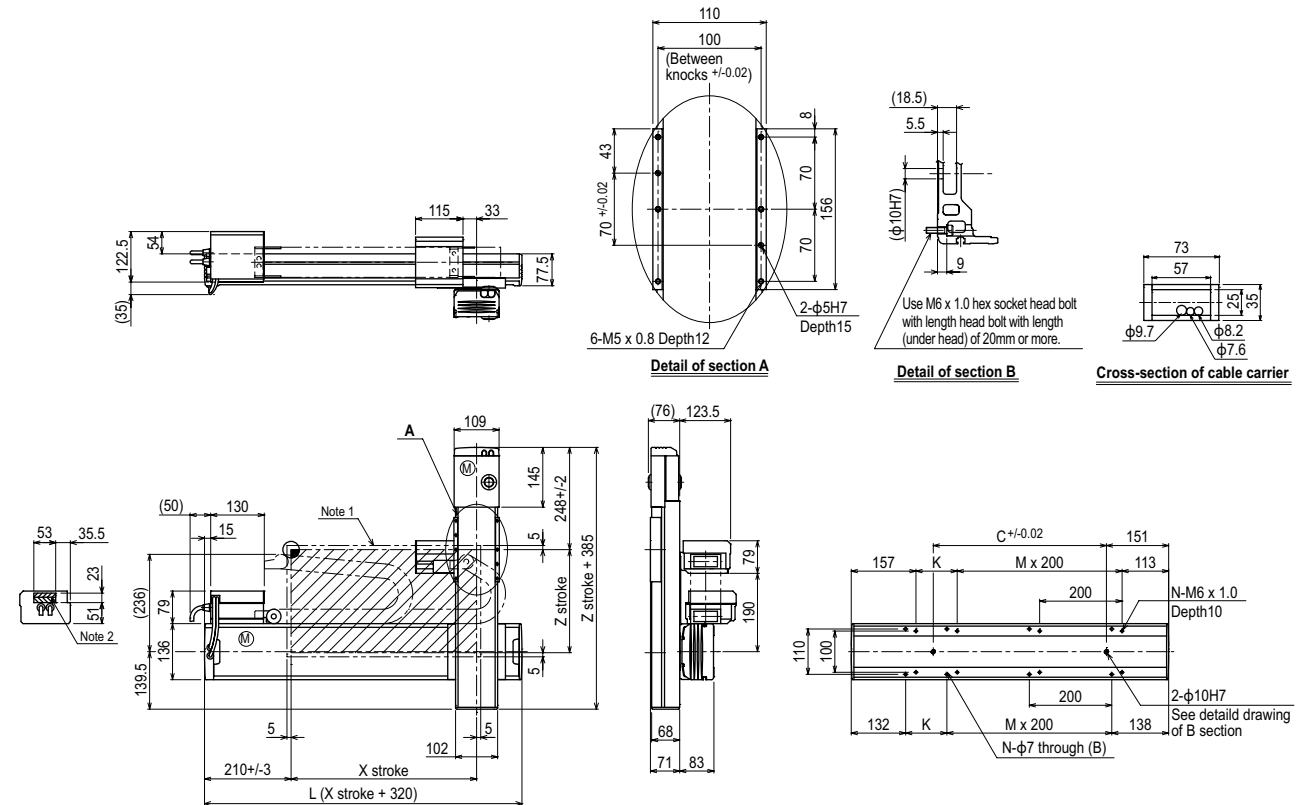

X stroke	150	250	350	450	550	650	750	850	950	1050			
L	470	570	670	770	870	970	1070	1170	1270	1370			
K	200	100	200	100	200	100	200	100	200	100			
C	240	240	420	420	600	600	780	960	960	1140			
M	0	1	1	2	2	3	3	4	4	5			
N	4	6	6	8	8	10	10	12	12	14			
Z stroke	150	250	350										
Maximum speed for each stroke (mm/sec) ^{Note 3}	X-axis		1200			960		780		600		540	
Speed setting			-			80%		65%		50%		45%	

- Note 1. The moving range when returning to origin and the stop position when stopping by the mechanical stopper.
 Note 2. The shaded position indicates a user cable extraction port.

- Note 3. When the X-axis stroke is longer than 750mm, resonance of the ball screw may occur depending on the operation conditions (critical speed). In this case, reduce the speed setting on the program by referring to the maximum speeds shown in the table at the left.

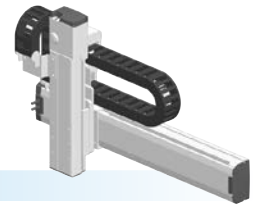

Ordering method

MXYx - C [] [] **ZFH** [] [] [] []

Model [] **Cable** [] **Combination** [] **X-axis stroke** [] **ZR-axis** [] **Z-axis stroke** [] **Cable** []

RCX320-2 [] [] **R** [] [] [] [] [] []

RCX222 [] [] **R** [] [] [] [] [] []

Specify various controller setting items. RCX320 ▶ **P.548**
Specify various controller setting items. RCX222 ▶ **P.558**

Specification

	X-axis	Z-axis
Axis construction <small>Note 1</small>	F14H	F10H-BK
AC servo motor output (W)	200	200
Repeatability <small>Note 2</small> (mm)	+/-0.01	+/-0.01
Drive system	Ball screw φ15	Ball screw φ15
Ball screw lead <small>Note 3</small> (Deceleration ratio) (mm)	20	10
Maximum speed <small>Note 4</small> (mm/sec)	1200	600
Moving range (mm)	150 to 1050	150 to 350
Robot cable length (m)	Standard: 3.5 Option: 5, 10	

Note 1. Use caution that the flange machining (installation holes, tap holes) differs from single-axis robots.
 Note 2. Positioning repeatability in one direction.
 Note 3. Leads not listed in the catalog are also available. Contact us for details.
 Note 4. When the X-axis stroke is longer than 750mm, resonance of the ball screw may occur depending on the operation conditions (critical speed). In this case, reduce the speed setting on the program by referring to the maximum speeds shown in the table below.

Maximum payload (kg)

	Z stroke (mm)		
X stroke (mm)	150	250	350
150 to 1050	14	13	12

Controller

Controller	Operation method
RCX320-R RCX222-R	Programming / I/O point trace / Remote command / Operation using RS-232C communication

MXYx 2 axes / ZFH (F1)

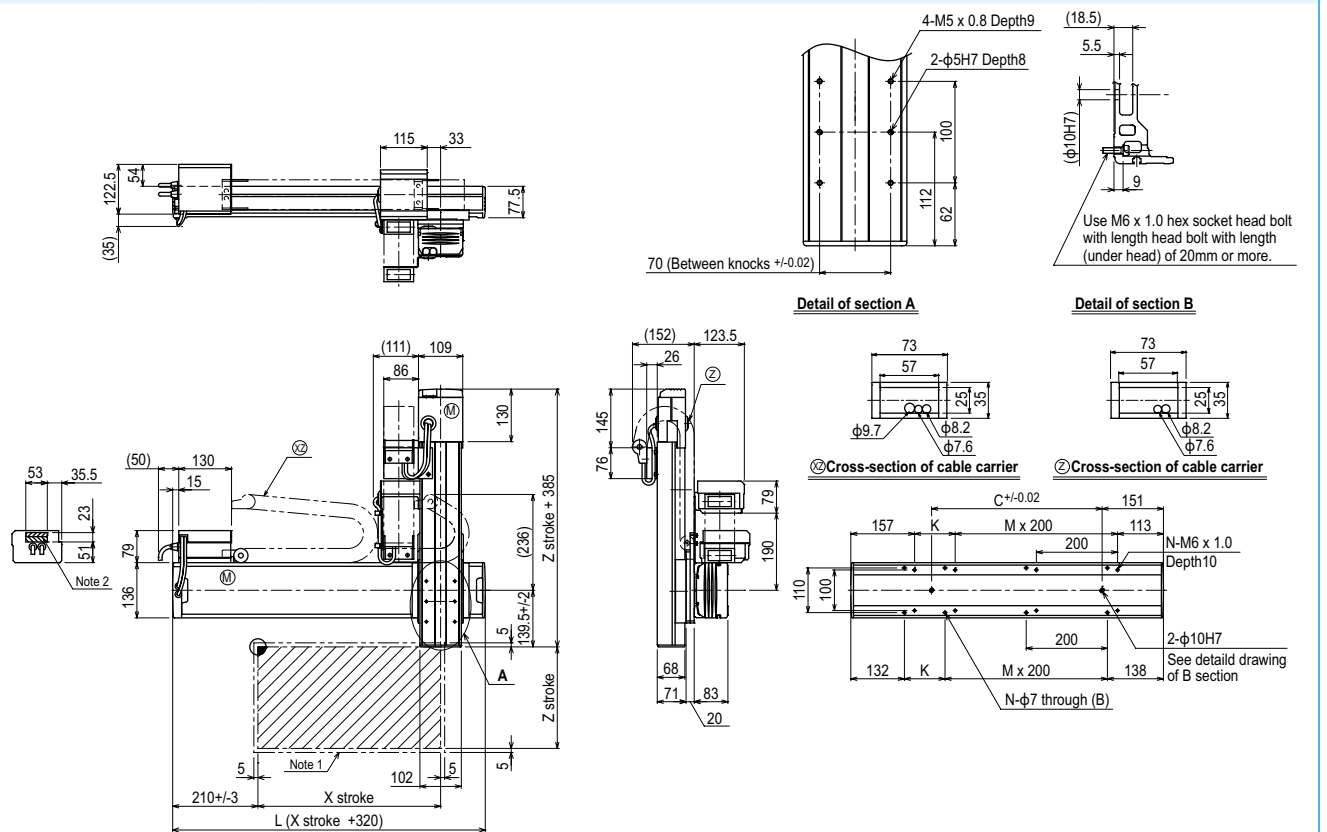

X stroke	150	250	350	450	550	650	750	850	950	1050	
L	470	570	670	770	870	970	1070	1170	1270	1370	
K	200	100	200	100	200	100	200	100	200	100	
C	240	240	420	420	600	600	780	960	960	1140	
M	0	1	1	2	2	3	3	4	4	5	
N	4	6	6	8	8	10	10	12	12	14	
Z stroke	150	250	350								
Maximum speed for each stroke (mm/sec) <small>Note 3</small>	X-axis		1200				960	780	600	540	
Speed setting			-				80%	65%	50%	45%	

Note 1. The moving range when returning to origin and the stop position when stopping by the mechanical stopper.
 Note 2. The shaded position indicates a user cable extraction port.
 Note 3. When the X-axis stroke is longer than 750mm, resonance of the ball screw may occur depending on the operation conditions (critical speed). In this case, reduce the speed setting on the program by referring to the maximum speeds shown in the table at the left.

- Articulated robots
YA
- Linear conveyor modules
LCM100
- Motor-less single axis actuator
Robonity
- Compact single-axis robots
TRANSEVO
- Single-axis robots
FLIP-X
- Linear motor single-axis robots
PHASER
- Cartesian robots
XY-X
- SCARA robots
YK-X
- Pick & place robots
YP-X
- CLEAN
- CONTROLLER
- INFORMATION
- Arm type
- Gantry type
- Moving arm type
- Pole type
- XZ type

HXYx 2 axes / ZL

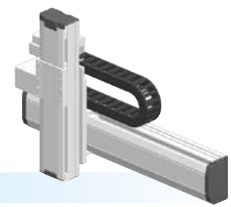

- XZ type
- Cable carrier
- Z-axis: clamped base / moving table type (200W)

Ordering method

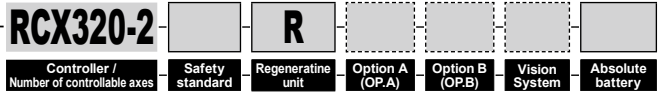
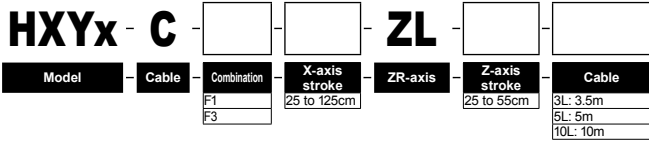

Specify various controller setting items. RCX320 ▶ **P.548**



Specify various controller setting items. RCX222 ▶ **P.558**

Specification

	X-axis	Z-axis
Axis construction ^{Note 1}	F17	F14H-BK
AC servo motor output (W)	400	200
Repeatability ^{Note 2} (mm)	+/-0.01	+/-0.01
Drive system	Ball screw φ20	Ball screw φ15
Ball screw lead ^{Note 3} (Deceleration ratio) (mm)	20	10
Maximum speed ^{Note 4} (mm/sec)	1200	600
Moving range (mm)	250 to 1250	250 to 550
Robot cable length (m)	Standard: 3.5 Option: 5,10	

- Note 1. Use caution that the flange machining (installation holes, tap holes) differs from single-axis robots.
 Note 2. Positioning repeatability in one direction.
 Note 3. Leads not listed in the catalog are also available. Contact us for details.
 Note 4. When the X-axis stroke is longer than 850mm, resonance of the ball screw may occur depending on the operation conditions (critical speed). In this case, reduce the speed setting on the program by referring to the maximum speeds shown in the table below.

Maximum payload (kg)

X stroke (mm)	Z stroke (mm)
250 to 1250	250 to 550
	20

Controller

Controller	Operation method
RCX320-R	Programming / I/O point trace / Remote command / Operation using RS-232C communication
RCX222-R	

HXYx 2 axes / ZL (F1)

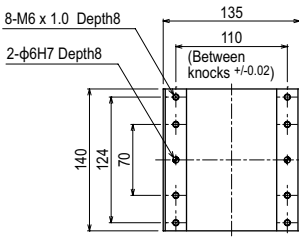

Detail of section A

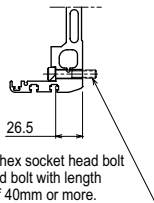

Detail of section B

Use M8 x 1.25 hex socket head bolt with length head bolt with length (under head) of 40mm or more.

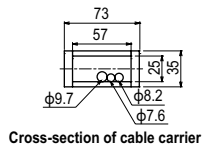

Cross-section of cable carrier

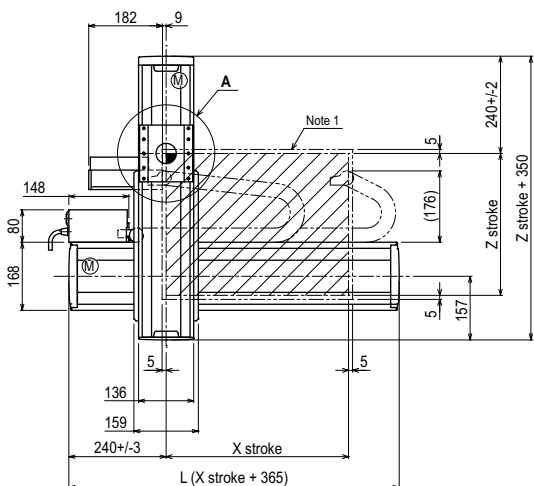
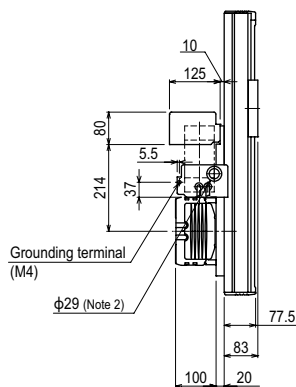
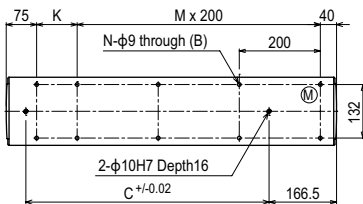

X stroke	250	350	450	550	650	750	850	950	1050	1150	1250	
L	615	715	815	915	1015	1115	1215	1315	1415	1515	1615	
K	100	200	100	200	100	200	100	200	100	200	100	
C	240	420	600	600	780	780	960	960	1140	1140	1320	
M	2	2	3	3	4	4	5	5	6	6	7	
N	8	8	10	10	12	12	14	14	16	16	18	
Z stroke	250	350	450	550								
Maximum speed for each stroke (mm/sec) ^{Note 3}	X-axis		1200				960		840	720	600	480
Speed setting			-				80%		70%	60%	50%	40%

- Note 1. The moving range when returning to origin and the stop position when stopping by the mechanical stopper.
 Note 2. User cable extraction port.

Note 3. When the X-axis stroke is longer than 850mm, resonance of the ball screw may occur depending on the operation conditions (critical speed). In this case, reduce the speed setting on the program by referring to the maximum speeds shown in the table at the left.

HXYx 2 axes / ZH

XZ type
Cable carrier
Z-axis: clamped table / moving base type (200W)

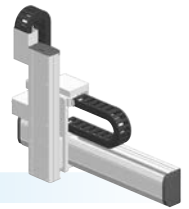

Ordering method

HXYx - C **ZH** **RCX320-2** **R**

Model	Cable	Combination	X-axis stroke	ZR-axis	Z-axis stroke	Cable	Controller / Number of controllable axes	Safety standard	Regenerative unit	Option A (OP.A)	Option B (OP.B)	Vision System	Absolute battery
F1 F3			25 to 125cm		25 to 55cm	3L: 3.5m 5L: 5m 10L: 10m	RCX320-2		R				

Specify various controller setting items. RCX320 ▶ **P.548**

Controller	Usable for CE	Regenerative unit	I/O selection 1	I/O selection 2
RCX222		R		

Specify various controller setting items. RCX222 ▶ **P.558**

Specification

	X-axis	Z-axis
Axis construction <small>Note 1</small>	F17	F14H-BK
AC servo motor output (W)	400	200
Repeatability <small>Note 2</small> (mm)	+/-0.01	+/-0.01
Drive system	Ball screw φ20	Ball screw φ15
Ball screw lead <small>Note 3</small> (Deceleration ratio) (mm)	20	5
Maximum speed <small>Note 4</small> (mm/sec)	1200	300
Moving range (mm)	250 to 1250	250 to 550
Robot cable length (m)	Standard: 3.5 Option: 5, 10	

Note 1. Use caution that the flange machining (installation holes, tap holes) differs from single-axis robots.
 Note 2. Positioning repeatability in one direction.
 Note 3. Leads not listed in the catalog are also available. Contact us for details.
 Note 4. When the X-axis stroke is longer than 850mm, resonance of the ball screw may occur depending on the operation conditions (critical speed). In this case, reduce the speed setting on the program by referring to the maximum speeds shown in the table below.

Maximum payload (kg)

X stroke (mm)	Z stroke (mm)
250 to 1250	30

Controller

Controller	Operation method
RCX320-R RCX222-R	Programming / I/O point trace / Remote command / Operation using RS-232C communication

HXYx 2 axes / ZH F1

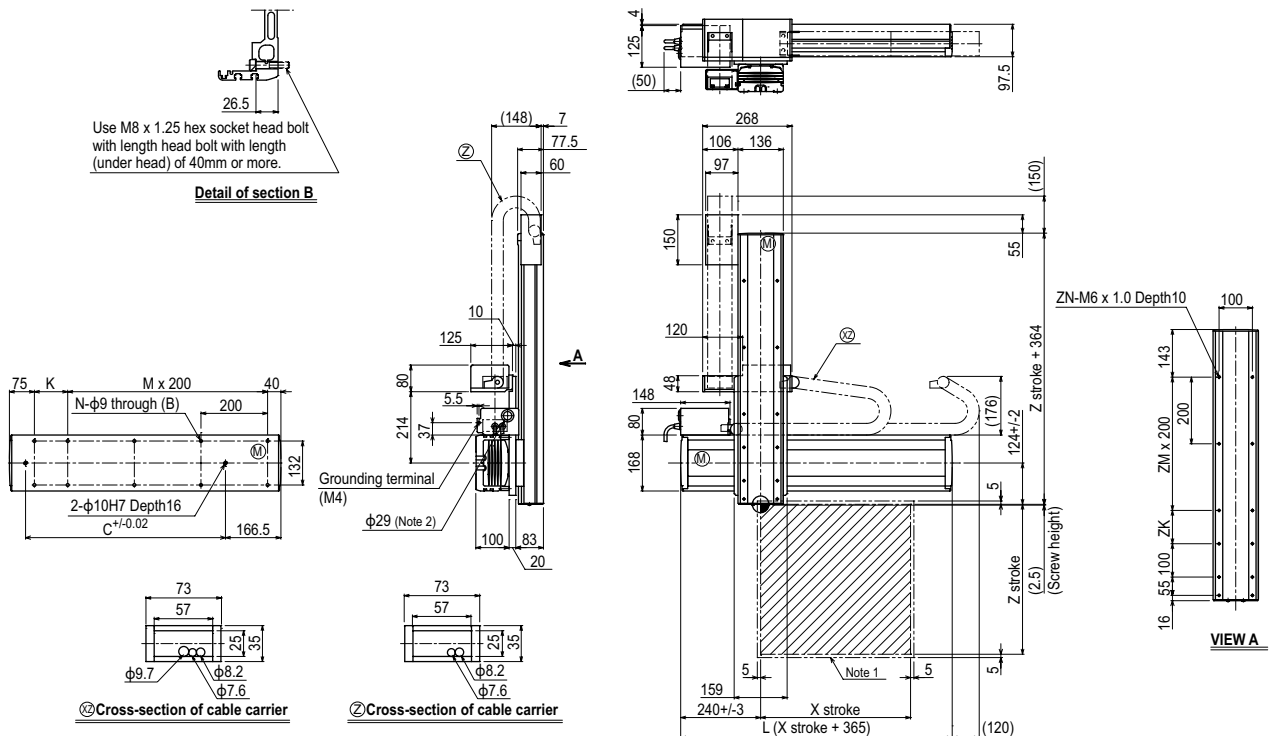

X stroke	250	350	450	550	650	750	850	950	1050	1150	1250
	L	615	715	815	915	1015	1115	1215	1315	1415	1515
K	100	200	100	200	100	200	100	200	100	200	100
C	240	420	600	600	780	780	960	960	1140	1140	1320
M	2	2	3	3	4	4	5	5	6	6	7
N	8	8	10	10	12	12	14	14	16	16	18

Z stroke	250	350	450	550
ZK	100	200	100	200
ZM	1	1	2	2
ZN	10	10	12	12

Note 1. The moving range when returning to origin and the stop position when stopping by the mechanical stopper.
 Note 2. User cable extraction port.

Maximum speed for each stroke (mm/sec) <small>Note 3</small>	X-axis						
	Speed setting		1200	960	840	720	600

Note 3. When the X-axis stroke is longer than 850mm, resonance of the ball screw may occur depending on the operation conditions (critical speed). In this case, reduce the speed setting on the program by referring to the maximum speeds shown in the table at the left.

Articulated robots
YA
 Linear conveyor modules
LCM100
 Motor-less single axis actuator
Robonity
 Compact single-axis robots
TRANSEVO
 Single-axis robots
FLIP-X
 Linear motor single-axis robots
PHASER
 Cartesian robots
XY-X
 SCARA robots
YK-X
 Pick & place robots
YP-X
 CLEAN
 CONTROLLER INFORMATION
 Arm type
 Gantry type
 Moving arm type
 Pole type
XZ type

MEMO

Articulated robots
YA

Linear conveyor
modules
LCM100

Motor-less single
axis actuator
Robonity

Compact
single-axis robots
TRANSERVO

Single-axis robots
FLIP-X

Linear motor
single-axis robots
PHASER

Cartesian
robots
XY-X

SCARA
robots
YK-X

Pick & place
robots
YP-X

CLEAN

CONTROLLER

INFORMATION

Arm type

Gantry type

Moving arm
type

Pole type

XZ type