

CLEAN Type

Product Lineup

CLEAN ROBOTS

Suitable for electronics component, food, and medical unit related work in clean room.

High sealing structure, dust generation prevention, and improvement of suction efficiency are achieved.

Both the high cleanliness degree and high performance are established.

Clean robots contribute to automation and labor saving of production systems in clean rooms.



Both high cleanliness degree and high performance were achieved. Clean single-axis, Cartesian, and SCARA robots were added to the product lineup.

Clean SCARA robots

YK-XGC/XC type

The Z-axis spline is covered with bellows made of materials with low dust generation and other sliding parts are sealed completely. Harnesses are also incorporated completely and the inside of the robot is sucked from the rear of the base to prevent dust generation.

- Arm length: 180 mm to 1000 mm
- Suction amount: 30 to 60 Nℓ/min.
- Cleanliness degree: CLASS ISO3 (ISO14644-1)
CLASS10 (FED-STD-209D)
- Maximum payload: 20 kg



POINT 1

Vertical bellows structure improves the reliability of the clean performance.

As a beltless structure is used, no dust generation caused by the belt occurs. Furthermore, as the YK-XGC type was renewed to a structure, in which the bellows are installed on the Z-axis vertically, the reliability of the clean performance was further improved.

Note. Except for YK500XC to YK1000XC



POINT 2

High durability

As a beltless structure is used, the robot can be operated without worry about belt elongation and secular change ^{Note}. Additionally, the bellows installed on the Z-axis use material with high durability to ensure the durability performance.

Note. Except for YK500XC to YK1000XC

POINT 3

Completely beltless structure improves the rigidity.

A completely beltless structure was achieved using a ZR-axis direct coupling structure. As a speed reducer is coupled to the tip rotation axis, the R-axis tolerable moment of inertia is very high and the high-speed movement is possible even with a heavy workpiece or largely offset workpiece.

Note. Except for YK500XC to YK1000XC

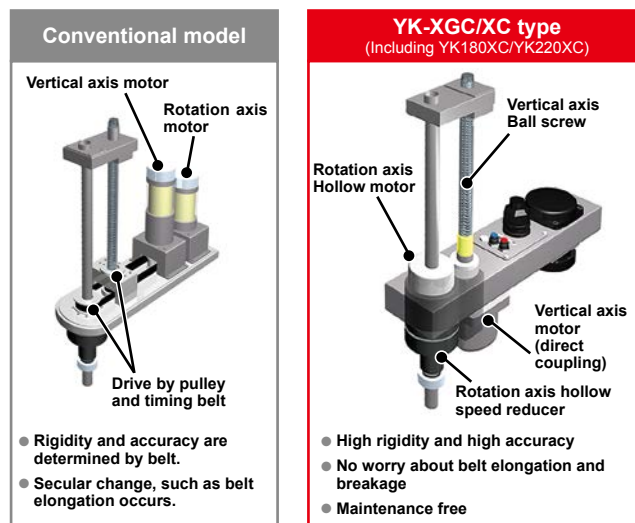

Type	Model	Arm length (mm)	Maximum payload (kg)	Standard cycle time (sec.)	Beltless structure	Page
Micro-mini type	YK180XC	180	1	0.42	○	P.462
	YK220XC	220	1	0.45	○	P.463
Small type	YK250XGC	250	4	0.57	○	P.464
	YK350XGC	350	4	0.57	○	P.466
	YK400XGC	400	4	0.57	○	P.468
Medium type	YK500XC	500	10	0.53	-	P.472
	YK500XGLC	500	4	0.74	○	P.470
	YK600XC	600	10	0.56	-	P.475
	YK600XGLC	600	4	0.74	○	P.473
Large type	YK700XC	700	20	0.57	-	P.476
	YK800XC	800	20	0.57	-	P.477
	YK1000XC	1000	20	0.60	-	P.478

Clean single-axis robots

FLIP-XC type

P.442

The FLIP-XC type robots are single-axis robots "FLIP-X series" with clean room specifications. According to the applications, an optimal robot can be selected from 14 models from a lightweight and compact model to a large model with a maximum payload of 120 kg. As an air joint for suction is provided as standard equipment, grease with low dust generative characteristics is used, and stainless sheets with an excellent durability are used for the slide table surface, high cleanliness degree is achieved.

- Stroke: 50 to 2050 mm
- Suction amount: 15 to 90 Nℓ/min.
- Cleanliness degree: CLASS10^{Note}
- Maximum payload: 120 kg (When installed horizontally)

Note. C4L/C4LH, C5L/C5LH, and C6L are CLASS ISO3 (ISO14644-1).



POINT

Excellent maintenance ability

For C4L to C6L models, removing the screws from the side panel of the slider will allow replacement of the inner roller without detaching the tool. For C8 to C20 models, even when the direct coupling structure is used, the motor or ball screw can be replaced individually.

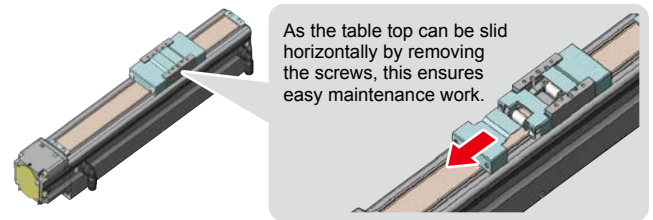

Model	Size (mm) ^{Note}	Lead (mm)	Maximum payload (kg)		Maximum speed (mm/sec.)	Stroke (mm)	Page
			Horizontal	Vertical			
C4L C4LH	W45 × H55	12	4.5	1.2	720	50 to 400	C4L : P.442 C4LH : P.443
		6	6	2.4	360		
		2	6	7.2	120		
C5L C5LH	W55 × H65	20	3	-	1000	50 to 800	C5L : P.444 C5LH : P.445
		12	5	1.2	800		
		6	9	2.4	400		
C6L	W65 × H65	20	10	-	1000	50 to 800	P.446
		12	12	4	800		
		6	30	8	400		
C8	W80 × H75	20	12	-	1000	150 to 800	P.447
		12	20	4	720		
		6	40	8	360		
C8L	W80 × H75	20	20	4	1000	150 to 1050	P.448
		10	40	8	600		
		5	50	16	300		
C8LH	W80 × H75	20	30	-	1000	150 to 1050	P.449
		10	60	-	600		
		5	80	-	300		
C10	W104 × H85	20	20	4	1000	150 to 1050	P.450
		10	40	10	500		
		5	60	20	250		
C14	W136 × H96	20	30	4	1000	150 to 1050	P.451
		10	55	10	500		
		5	80	20	250		
C14H	W136 × H96	20	40	8	1000	150 to 1050	P.452
		10	80	20	500		
		5	100	30	250		
C17	W168 × H114	20	80	15	1000	250 to 1250	P.453
		10	120	35	600		
C17L	W168 × H114	50	50	10	1000	1150 to 2050	P.454
C20	W202 × H117	20	120	25	1000	250 to 1250	P.455
		10	-	45	500		

Note 1. The size shows approximate maximum cross sectional size.

Clean single-axis robots

SSC type (TRANSERVO)

P.439

The SSC type robots are stepping motor single-axis robots "TRANSERVO series" with clean room specifications. Use of a newly developed vector control method achieves the function and performance equivalent to the servomotor at a low cost even using the stepping motor. As an air joint for suction is provided as standard equipment, grease with low dust generative characteristics is used and stainless sheets with an excellent durability are used for the slide table surface, the high cleanliness degree is achieved.

- Stroke: 50 to 800 mm
- Suction amount: 15 to 80 Nℓ/min.
- Cleanliness degree: CLASS10
- Maximum payload: 12 kg (When installed horizontally)



Model	Size (mm) ^{Note 1}	Lead (mm)	Maximum payload (kg)		Maximum speed (mm/sec.)	Stroke (mm)	Page
			Horizontal	Vertical			
SSC04	W49 × H59	12	2	1	600	50 to 400	P.439
		6	4	2	300		
		2	6	4	100		
SSC05	W55 × H56	20	4	-	1000	50 to 800	P.440
		12	6	1	600		
		6	10	2	300		
SSC05H	W55 × H56	20	6	-	1000	50 to 800	P.441
		12	8	2	600 (horizontal) / 500 (vertical)		
		6	12	4	300 (horizontal) / 250 (vertical)		

Note 1. The size shows approximate maximum cross sectional size.

Clean Cartesian robots

XY-XC type

P.456

This Cartesian robot XY-XC type is applicable to clean rooms. As stainless sheets with excellent durability are used, the opening can be designed to be its minimum level and the robots area applicable to CLASS10 with less suction amount. Furthermore, as the ZR-axis of the SXYxC uses a super high speed unit of the SCARA robot, this achieves great reduction of the cycle time.

- Suction amount: 60 to 90 Nℓ/min.
- Cleanliness degree: CLASS10 ^{Note}
- Maximum payload: 20 kg
- Maximum speed: 1000 mm/sec.

Note. User wiring: D-Sub 25-pin connector (Numbers 1 to 24 are already wired and number 25 is frame ground.)
Note. User tubing: φ 6-air tube, 3 pcs.



Type	Model	Axis	Movement range	Maximum speed (mm/sec.)	Maximum payload (kg)	Page
2 axes	SXYxC	X	150 to 1050 mm	1000	20	P.456
		Y	150 to 650 mm	1000		
3 axes	SXYxC (ZSC12)	X	150 to 1050 mm	1000	3	P.458
		Y	150 to 650 mm	1000		
		Z	150 mm	1000		
3 axes	SXYxC (ZSC6)	X	150 to 1050 mm	1000	5	P.459
		Y	150 to 650 mm	1000		
		Z	150 mm	500		
4 axes	SXYxC (ZRSC12)	X	150 to 1050 mm	1000	3	P.460
		Y	150 to 650 mm	1000		
		Z	150 mm	1000		
		R	360 °	1020 °/sec		
4 axes	SXYxC (ZRSC6)	X	150 to 1050 mm	1000	5	P.461
		Y	150 to 650 mm	1000		
		Z	150 mm	500		
		R	360 °	1020 °/sec		



CLEAN ROBOTS

CLEAN

TYPE

Articulated robots	YA
Linear conveyor modules	LCM100
Compact single-axis robots	TRANSERVO
Single-axis robots	FLIP-X
Linear motor single-axis robots	PHASER
Cartesian robots	XY-X
SCARA robots	YK-X
Pick & place robots	YP-X
CLEAN	
CONTROLLER	
INFORMATION	
Single-axis	
Cartesian	
SCARA	

CONTENTS

■ CLEAN ROBOTS SPECIFICATION SHEET 436

SINGLE-AXIS

● TRANSERVO

SSC04	439
SSC05	440
SSC05H	441

● FLIP-XC

C4L	442
C4LH	443
C5L	444
C5LH	445
C6L	446
C8	447
C8L	448
C8LH	449
C10	450
C14	451
C14H	452
C17	453
C17L	454
C20	455

CARTESIAN XY-XC

● 2 axes

SXYxC	456
-------	-----

● 3 axes / ZSC

SXYxC	458
-------	-----

● 4 axes / ZRSC

SXYxC	460
-------	-----

SCARA YK-XC

YK180XC	462
YK220XC	463
YK250XGC	464
YK350XGC	466
YK400XGC	468
YK500XGLC	470
YK500XC	472
YK600XGLC	473
YK600XC	475
YK700XC	476
YK800XC	477
YK1000XC	478

CLEAN ROBOTS SPECIFICATION SHEET

Clean single-axis robots

●TRANSERVO

- Degree of cleanliness CLASS 10
- Intake air 15 to 80Nℓ/min

Model	Lead (mm)	Payload (kg)		Stroke (mm) and maximum speed (mm/sec)																Detailed info page		
		Horizontal	Vertical	50	100	150	200	250	300	350	400	450	500	550	600	650	700	750	800			
SSC04	12	2	1	600																		P.439
	6	4	2	300																		
	2	6	4	100																		
SSC05	20	4	–	1000						933	833	733	633							P.440		
	12	6	1	600						560	500	440	380									
	6	10	2	300						280	250	220	190									
SSC05H	20	6	–	1000						933	833	733	633							P.441		
	12	8	–	600						560	500	440	380									
		–	2	500										440	380							
	6	12	–	300						280	250	220	190									
		–	4	250										220	190							

●FLIP-XC

- Degree of cleanliness C4L/C4LH/C5L/C5LH/C6L ISO CLASS 3 (ISO14644-1) ^{Note}
Models other than those shown above CLASS 10
Note. Class 10 (0.1µm) equivalent to FED-STD-209D
- Intake air 20 to 90Nℓ/min

Model	AC servo motor output (W)	Repeatability (mm)	Lead (mm)	Payload (kg)		Stroke (mm) and maximum speed (mm/sec)																				
				Horizontal	Vertical	50	100	150	200	250	300	350	400	450	500	550	600	650	700	750	800	850	900	950		
C4L / C4LH	30	+/-0.02	12	4.5	1.2	720																				
			6	6	2.4	360																				
			2	6	7.2	120																				
C5L / C5LH	30	+/-0.02	20	3	–	1000																				
			12	5	1.2	800																				
			6	9	2.4	400																				
C6L	60	+/-0.02	20	10	–	1000																				
			12	12	4	800																				
			6	30	8	400																				
C8	100	+/-0.02	20	12	–	1000						900	800	700	650											
			12	20	4	720						648	540	468	432	360										
			6	40	8	360						324	270	234	216	180										
C8L	100	+/-0.01	20	20	4	1000						900	800	700	650	600										
			10	40	8	600						510	450	390	360	330	300									
			5	50	16	300						255	225	195	180	165	150									
C8LH	100	+/-0.01	20	30	–	1000						900	800	700	650	600	550									
			10	60	–	600						510	450	390	360	330	300	270								
			5	80	–	300						255	225	195	180	165	150	135								
C10	100	+/-0.01	20	20	4	1000						950	850	750	600											
			10	40	10	500						475	425	375	300											
			5	60	20	250						237	212	187	150											
C14	100	+/-0.01	20	30	4	1000						950	850	750	600											
			10	55	10	500						475	425	375	300											
			5	80	20	250						237	212	187	150											
C14H	200	+/-0.01	20	40	8	1000						950	850	750	600											
			10	80	20	500						475	425	375	300											
			5	100	30	250						237	212	187	150											
C17	400	+/-0.01	20	80	15	1000						800														
			10	120	35	500						400														
C17L	600	+/-0.02	50	50	10																					
C20	600	+/-0.01	20	120	25	1000						800														
			10	–	45	500						400														

																					Detailed info page				
	1000	1050	1100	1150	1200	1250	1300	1350	1400	1450	1500	1550	1600	1650	1700	1750	1800	1850	1900	1950	2000	2050			
																								C4L : P.442 C4LH : P.443	
																									C5L : P.444 C5LH : P.445
																									P.446
																									P.447
	550	500																							P.448
	270	240																							P.449
	135	120																							P.449
	500	450																							P.450
	240	210																							P.451
	120	105																							P.452
	600	500																							P.453
	300	250																							P.454
	150	125																							P.455
	600	500																							P.453
	300	250																							P.454
	150	125																							P.455
	800	700	600	500																					P.454
	400	350	300	250																					P.455
			1000	1000	1000	1000	1000	1000	1000	1000	900	800	800												P.454
	800	700	600	500																					P.455
	400	350	300	250																					P.455

Clean cartesian robots

● XY-XC

- Degree of cleanliness CLASS 10
- Intake air 60 to 90Nℓ/min
- Aperture designed to minimal dimensions by use of stainless steel sheet
- Installed clean robot dedicated cable duct

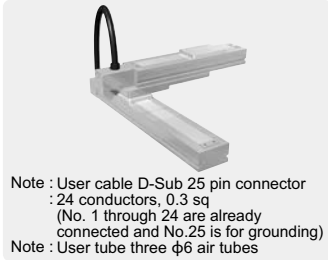

Arm variations

Special model for clean rooms with moving Y-axis carriage installed upward.

Type	Model	Axis	Moving range	Maximum speed (mm/sec)	Maximum payload (kg)	Detailed info page
2 axes	SXYXC	X	150 to 1050mm	1000	20	P.456
		Y	150 to 650mm	1000		
3 axes	SXYXC (ZSC12)	X	150 to 1050mm	1000	3	P.458
		Y	150 to 650mm	1000		
		Z	150mm	1000		
	SXYXC (ZSC6)	X	150 to 1050mm	1000	5	P.458
		Y	150 to 650mm	1000		
		Z	150mm	500		
4 axes	SXYXC (ZRSC12)	X	150 to 1050mm	1000	3	P.460
		Y	150 to 650mm	1000		
		Z	150mm	1000		
		R	360°	1020°/sec		
	SXYXC (ZRSC6)	X	150 to 1050mm	1000	5	P.460
		Y	150 to 650mm	1000		
		Z	150mm	500		
		R	360°	1020°/sec		

Clean SCARA robots

● YK-XC/YK-XGC/YK-XGLC

- Degree of cleanliness YK-XC CLASS 10
YK-XGC/YK-XGLC... ISO CLASS 3 (ISO14644-1) ^{Note}
Note. Class 10 (0.1μm) equivalent to FED-STD-209D

- Intake air 30 to 60Nℓ/min
- Harness placed completely on inside

- Bellows cover fitted in axial tip



Passed 20 million stroke durability test

Type	Model	Arm length (mm) and XY axis combined maximum speed (m/s)														Standard cycle time (sec)	Maximum payload (kg)	R axis tolerable moment of inertia (kgm ²)	Detailed info page			
		120	150	180	220	250	300	350	400	500	600	700	800	900	1000					1200		
Tiny type	YK180XC	3.3m/s															0.42	1	0.01	P.462		
	YK220XC	3.4m/s																0.45	1	0.01	P.463	
Small type	YK250XGC	4.5m/s																0.57	4	0.05	P.464	
	YK350XGC	5.6m/s																0.57	4	0.05	P.466	
	YK400XGC	6.1m/s																0.57	4	0.05	P.468	
	YK500XGLC	5.1m/s																0.74	4	0.05	P.470	
Medium type	YK500XC	4.9m/s																0.53	10	0.12	P.472	
	YK600XGLC	4.9m/s																0.74	4	0.05	P.473	
	YK600XC	5.6m/s																0.56	10	0.12	P.475	
Large type	YK700XC	6.7m/s																0.57	20	0.32	P.476	
	YK800XC	7.3m/s																	0.57	20	0.32	P.477
	YK1000XC	8.0m/s																0.60	20	0.32	P.478	

SSC04

- CE compliance
- Origin on the non-motor side is selectable

Ordering method

SSC04		S						
Model	Lead	Type	Brake	Direction of air coupler installation	Origin position	Stroke	Cable length ^{Note 2}	
	12: 12mm 6: 6mm 2: 2mm	S: Straight	N: With no brake B: With brake	RJ: Right (Standard) LJ: Left	N: Standard ^{Note 1} Z: Non-motor side	50 to 400 (50mm pitch)	1L: 1m 3L: 3m 5L: 5m 10L: 10m	

Note 1. If changing from the origin position at the time of purchase, the machine reference amount must be reset. For details, refer to the manual.
 Note 2. The robot cable is flexible and resists bending.
 Note 3. See P.498 for DIN rail mounting bracket.
 Note 4. Select this selection when using the gateway function. For details, see P.60.

Basic specifications

Motor	42 □ Step motor
Repeatability ^{Note 1} (mm)	+/-0.02
Deceleration mechanism	Ball screw φ8 (Class C10)
Maximum motor torque (N-m)	0.27
Ball screw lead (mm)	12 6 2
Maximum speed (mm/sec)	600 300 100
Maximum payload (kg)	Horizontal 2 4 6 Vertical 1 2 4
Max. pressing force (N)	45 90 150
Stroke (mm)	50 to 400 (50mm pitch)
Overall length (mm)	Horizontal Stroke+216 Vertical Stroke+261
Maximum outside dimension of body cross-section (mm)	W49 × H59
Cable length (m)	Standard: 1 / Option: 3, 5, 10
Degree of cleanliness	CLASS 10 ^{Note 2}
Intake air (Nl/min)	Lead 12 Lead 6 Lead 2 50 30 15

Note 1. Positioning repeatability in one direction.
 Note 2. Per 1cf (0.1µm base), when suction blower is used.

S2	S2	I/O
Robot positioner	S2: TS-S2 ^{Note 3}	NP: NPN PN: PNP CC: CC-Link DN: DeviceNet™ EP: EtherNet/IP™ PT: PROFINET GW: No I/O board ^{Note 4}
SH	SH	Battery
Robot positioner	SH: TS-SH	B: With battery (Absolute) N: None (Incremental)
SD	SD	1
Robot driver	SD: TS-SD	I/O cable 1: 1m

Allowable overhang

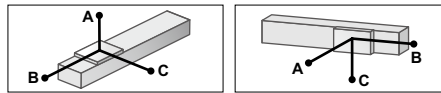

Horizontal installation (Unit: mm)				Wall installation (Unit: mm)				Vertical installation (Unit: mm)				
	A	B	C		A	B	C		A	C		
Lead 12	1kg	807	218	292	1kg	274	204	776	Lead 12	0.5kg	407	408
	2kg	667	107	152	2kg	133	93	611		1kg	204	204
Lead 6	2kg	687	116	169	2kg	149	102	656	Lead 6	1kg	223	223
	3kg	556	76	112	3kg	92	62	516		2kg	107	107
	4kg	567	56	84	4kg	63	43	507	Lead 2	2kg	118	118
Lead 2	4kg	869	61	92	4kg	72	48	829		4kg	53	53
	6kg	863	40	60	6kg	39	29	789				

Note. Distance from center of slider upper surface to conveyor center-of-gravity at a guide service life of 10,000 km (Service life is calculated for 400mm stroke models).

Static loading moment

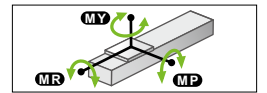

(Unit: N-m)		
MY	MP	MR
16	19	17

Controller

Controller	Operation method
TS-S2	I/O point trace / Remote command
TS-SH	Remote command
TS-SD	Pulse train control

SSC04

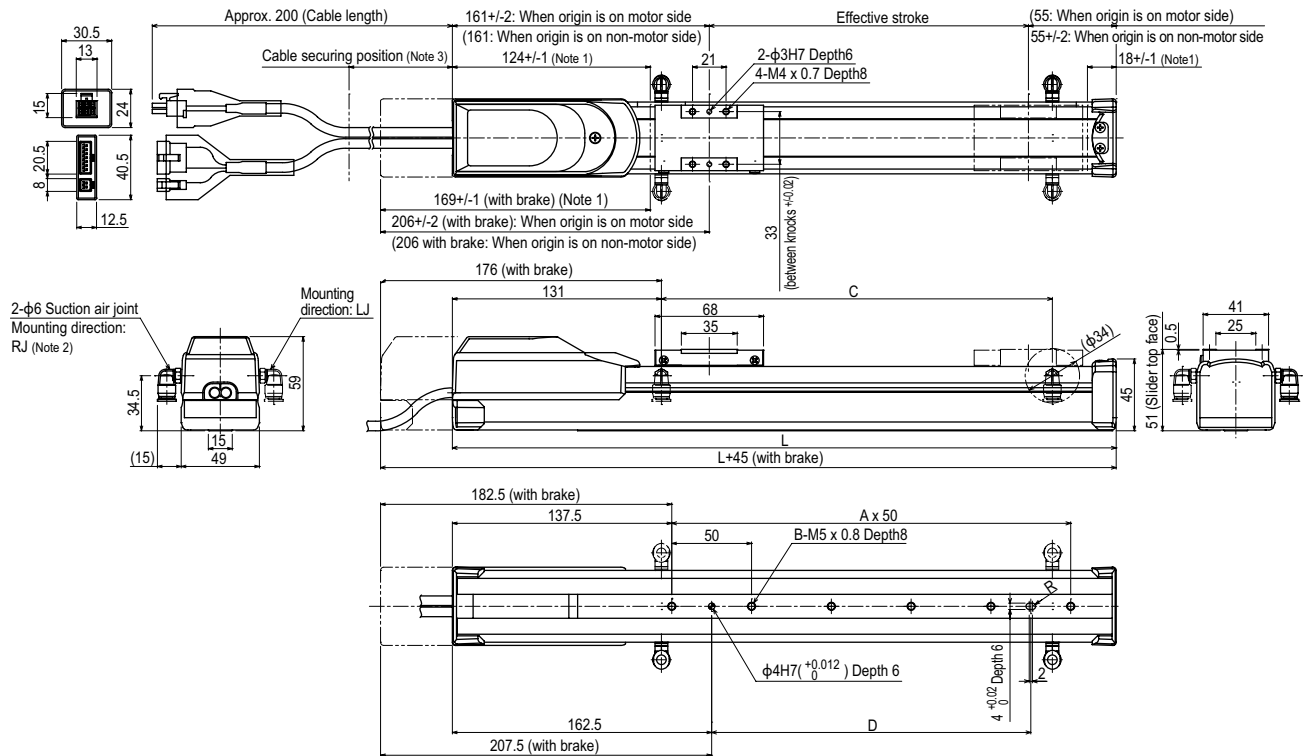

Effective stroke	50	100	150	200	250	300	350	400
L	266	316	366	416	466	516	566	616
A	2	3	4	5	6	7	8	9
B	3	4	5	6	7	8	9	10
C	50	100	150	200	250	300	350	400
Weight (kg) ^{Note 5}	1.5	1.6	1.7	1.8	2.0	2.1	2.2	2.3

Note 1. Stop positions are determined by the mechanical stoppers at both ends.
 Note 2. Either right or left can be selected for the suction air joint mounting direction. This drawing shows the RJ (standard) direction.
 Note 3. Secure the cable with a tie-band 100mm or less from unit's end face to prevent the cable from being subjected to excessive loads.
 Note 4. The cable's minimum bend radius is R30.
 Note 5. These are the weights without a brake. The weights are 0.2kg heavier when equipped with a brake.

Articulated robots
YA

Linear conveyor modules
LCM100

Compact single-axis robots
TRANSEVO

Single-axis robots
FLIP-X

Linear motor single-axis robots
PHASER

Cartesian robots
XY-X

SCARA robots
YK-X

Pick & place robots
YP-X

CLEAN

CONTROLLER INFORMATION

Single-axis
Cartesian
SCARA

SSC05



- High lead: Lead 20
- CE compliance
- Origin on the non-motor side is selectable

Ordering method

SSC05	S						
Model	Lead	Type	Brake ^{Note 1}	Direction of air coupler installation	Origin position	Stroke	Cable length ^{Note 3}
	20: 20mm 12: 12mm 6: 6mm	S: Straight	N: With no brake B: With brake	RJ: Right (Standard) LJ: Left	N: Standard ^{Note 2} Z: Non-motor side	50 to 800 (50mm pitch)	1L: 1m 3L: 3m 5L: 5m 10L: 10m

S2		
Robot positioner	I/O	Battery
S2: TS-S2 ^{Note 4}	NP: NPN PN: PNP CC: CC-Link DN: DeviceNet™ EP: EtherNet/IP™ PT: PROFINET GW: No I/O board ^{Note 5}	B: With battery (Absolute) N: None (Incremental)
SH		
Robot positioner	I/O	Battery
SH: TS-SH	NP: NPN PN: PNP CC: CC-Link DN: DeviceNet™ EP: EtherNet/IP™ PT: PROFINET GW: No I/O board ^{Note 5}	B: With battery (Absolute) N: None (Incremental)
SD	1	
Robot driver	I/O cable	
SD: TS-SD	t: 1m	

Note 1. Only the model with a lead of 12mm or 6mm can select specifications with brake.
 Note 2. If changing from the origin position at the time of purchase, the machine reference amount must be reset. For details, refer to the manual.
 Note 3. The robot cable is flexible and resists bending.
 Note 4. See P.498 for DIN rail mounting bracket.
 Note 5. Select this selection when using the gateway function. For details, see P.60.

Basic specifications

Motor	42 □ Step motor
Repeatability ^{Note 1} (mm)	+/-0.02
Deceleration mechanism	Ball screw φ12 (Class C10)
Maximum motor torque (N·m)	0.27
Ball screw lead (mm)	20 12 6
Maximum speed (mm/sec) ^{Note 2}	1000 600 300
Maximum payload (kg)	Horizontal 4 6 10 Vertical - 1 2
Max. pressing force (N)	27 45 90
Stroke (mm)	50 to 800 (50mm pitch)
Overall length (mm)	Horizontal Stroke+230 Vertical Stroke+270
Maximum outside dimension of body cross-section (mm)	W55 × H56
Cable length (m)	Standard: 1 / Option: 3, 5, 10
Degree of cleanliness	CLASS 10 ^{Note 3}
Intake air (Nl/min)	Lead 20 Lead 12 Lead 6 80 50 30

Note 1. Positioning repeatability in one direction.
 Note 2. When the stroke is longer than 650mm, resonance of the ball screw may occur depending on the operation conditions (critical speed). In this case, reduce the speed setting on the program by referring to the maximum speeds shown in the table below.
 Note 3. Per 1cf (0.1µm base), when suction blower is used.

Allowable overhang ^{Note}

Horizontal installation (Unit: mm)				Wall installation (Unit: mm)				Vertical installation (Unit: mm)			
	A	B	C		A	B	C	Lead 20	Lead 12	Lead 6	
Lead 20	2kg	413	139	218	2kg	192	123	372	0.5kg	578	579
Lead 12	4kg	334	67	120	4kg	92	51	265	1kg	286	286
Lead 6	4kg	347	72	139	4kg	109	57	300	1kg	312	312
Lead 20	6kg	335	47	95	6kg	63	31	263	2kg	148	148
Lead 12	4kg	503	78	165	4kg	134	63	496			
Lead 6	8kg	332	37	79	6kg	76	35	377			
Lead 20	10kg	344	29	62	8kg	47	22	355			

Static loading moment

MY	MP	MR
25	33	30

(Unit: N·m)

Controller

Controller	Operation method
TS-S2	I/O point trace / Remote command
TS-SH	Remote command
TS-SD	Pulse train control

Note. Distance from center of slider upper surface to conveyor center-of-gravity at a guide service life of 10,000 km (Service life is calculated for 600mm stroke models).

SSC05

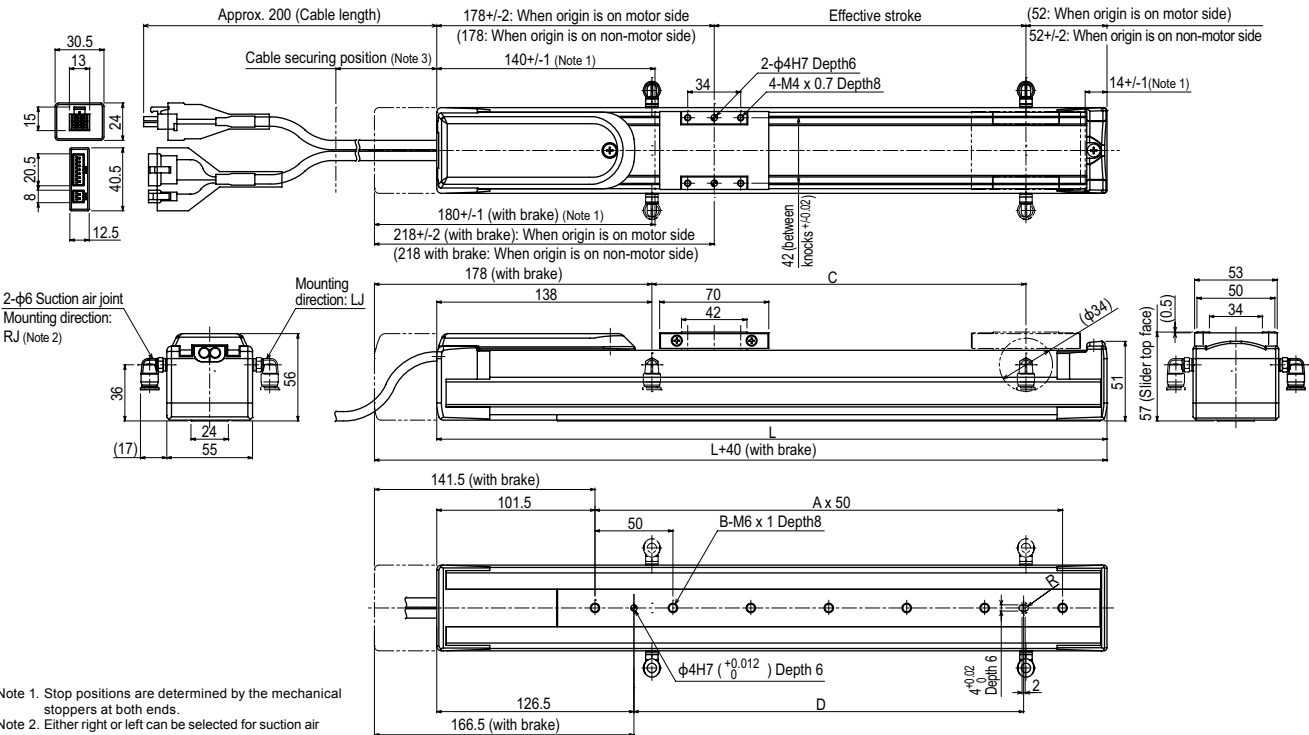

Note 1. Stop positions are determined by the mechanical stoppers at both ends.
 Note 2. Either right or left can be selected for suction air joint mounting direction. This drawing shows the RJ (standard) direction.
 Note 3. Secure the cable with a tie-band 100mm or less from unit's end face to prevent the cable from being subjected to excessive loads.
 Note 4. The cable's minimum bend radius is R30.
 Note 5. These are the weights without a brake. The weights are 0.2kg heavier when equipped with a brake.
 Note 6. When the stroke is longer than 650mm, resonance of the ball screw may occur depending on the operation conditions (critical speed). In this case, reduce the speed setting on the program by referring to the maximum speeds shown in the table at the left.

Effective stroke	50	100	150	200	250	300	350	400	450	500	550	600	650	700	750	800
L	280	330	380	430	480	530	580	630	680	730	780	830	880	930	980	1030
A	3	4	5	6	7	8	9	10	11	12	13	14	15	16	17	18
B	4	5	6	7	8	9	10	11	12	13	14	15	16	17	18	19
C	100	150	200	250	300	350	400	450	500	500	500	500	500	500	500	500
Weight (kg) ^{Note 5}	2.1	2.3	2.5	2.7	2.8	3.0	3.2	3.4	3.6	3.8	4.0	4.2	4.4	4.6	4.8	5.0
Maximum speed for each stroke (mm/sec) ^{Note 6}	1000												933	833	733	633
Lead 20													560	500	440	380
Lead 12													280	250	220	190
Lead 6																

C4L

Origin on the non-motor side is selectable



Ordering method

C4L							ERCD	
Model	Lead designation	Brake	Direction of air coupler installation	Origin position change	Stroke	Cable length ^{Note 1}	Controller	I/O connector specification
	12: 12mm 6: 6mm 2: 2mm	No entry: With no brake BK: With brake	L: Left (Standard) R: Right	None: Standard Z: Non-motor side	50 to 400 (50mm pitch)	1L: 1m 3L: 3.5m 5L: 5m 10L: 10m 1K/3K/5K/10K (Flexible cable)		CN1: I/O flat cable 1m (Standard) CN2: Twisted-pair cable 2m (pulse train function)

Note 1. The robot cable is standard cable (1L/3L/5L/10L), but can be changed to flexible cable. See P.594 for details on robot cable.

Basic specifications

AC servo motor output (W)	30
Repeatability ^{Note 1} (mm)	+/-0.02
Deceleration mechanism	Ball screw $\phi 8$ (Class C10)
Ball screw lead (mm)	12 6 2
Maximum speed (mm/sec)	720 360 120
Maximum payload (kg)	Horizontal 4.5 6 6 Vertical 1.2 2.4 7.2
Rated thrust (N)	32 64 153
Stroke (mm)	50 to 400 (50mm pitch)
Overall length (mm)	Horizontal Stroke+205 Vertical Stroke+240
Maximum outside dimension of body cross-section (mm)	W45×H55
Cable length (m)	Standard: 3.5 / Option: 1.5, 10
Degree of cleanliness	ISO CLASS 3 (ISO14644-1) ^{Note 2}
Intake air (Nl/min) ^{Note 3}	50 30 15

Note 1. Positioning repeatability in one direction.
 Note 2. CLASS 10 (0.1 μ m) FED-STD-209D or equivalent when a suction blower is used.
 Note 3. The necessary intake amount varies depending on the use conditions and environment.

Allowable overhang

Horizontal installation (Unit: mm)				Wall installation (Unit: mm)				Vertical installation (Unit: mm)		
	A	B	C		A	B	C	Lead 12	A	C
2kg	429	87	179	2kg	145	52	368	1.2kg	121	122
4.5kg	219	32	74	4.5kg	46	0	139	2.4kg	52	54
3kg	511	58	135	3kg	103	22	370	3kg	37	39
6kg	336	26	62	6kg	27	0	185	7.2kg	0	0
3kg	1571	58	142	3kg	109	23	1150			
6kg	751	27	66	6kg	27	0	420			

Note. Distance from center of slider top to center of gravity of object being carried at a guide service life of 10,000 km.
 Note. Service life is calculated for 300mm stroke models.

Static loading moment

(Unit: N·m)		
MY	MP	MR
15	19	18

Controller

Controller	Operation method
ERCD	Pulse train control / Programming / I/O point trace / Remote command / Operation using RS-232C communication

C4L

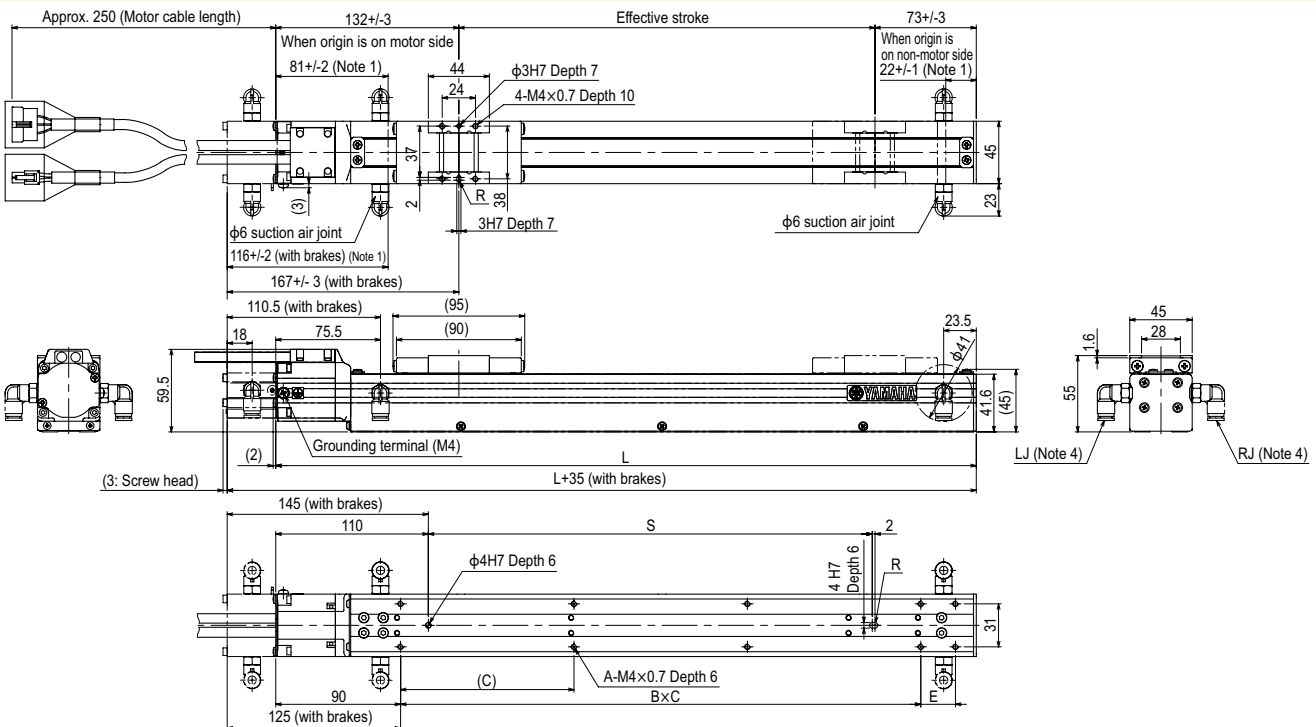

Effective stroke	50	100	150	200	250	300	350	400
L	255	305	355	405	455	505	555	605
A	4	6	6	8	8	10	10	10
B	1	2	2	2	2	3	3	4
C	150	100	125	125	125	125	125	125
E	0	0	0	50	100	25	75	0
S	70	120	170	220	270	320	370	420
Weight (kg) ^{Note 3}	1.4	1.5	1.7	1.8	2	2.1	2.3	2.4
Maximum speed for each stroke (mm/sec)	Lead 12	720						
	Lead 6	360						
	Lead 2	120						

Note 1. Stop positions are determined by the mechanical stoppers at both ends.
 Note 2. Minimum bend radius of motor cable is R30.
 Note 3. Weight of models with no brake. The weight of brake-attached models is 0.2 kg heavier than the models with no brake shown in the table.
 Note 4. Either right or left can be selected for the installation direction for the $\phi 6$ intake air joint. (The left side is the standard.)
 Note 5. External view of C4LH is identical to C4L.

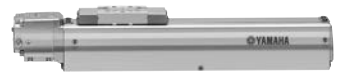

C5L

- High lead: Lead 20
- Origin on the non-motor side is selectable

Ordering method

C5L							ERCD	
Model	Lead designation 20: 20mm 12: 12mm 6: 6mm	Brake ^{Note 1} No entry: With no brake BK: With brake	Direction of air coupler installation L: Left (Standard) R: Right	Origin position change None: Standard Z: Non-motor side	Stroke 50 to 800 (50mm pitch)	Cable length ^{Note 2} 1L: 1m 3L: 3.5m 5L: 5m 10L: 10m 1K/3K/5K/10K (Flexible cable)	Controller	I/O connector specification CN1: I/O flat cable 1m (Standard) CN2: Twisted-pair cable 2m (pulse train function)

Note 1. The model with a lead of 20mm cannot select specifications with brake (vertical specifications).
 Note 2. The robot cable is standard cable (1L/3L/5L/10L), but can be changed to flexible cable.
 See P.594 for details on robot cable.

Basic specifications

AC servo motor output (W)	30
Repeatability ^{Note 1} (mm)	+/- 0.02
Deceleration mechanism	Ball screw $\phi 12$ (Class C10)
Ball screw lead (mm)	20 12 6
Maximum speed (mm/sec)	1000 800 400
Maximum payload (kg)	Horizontal 3 5 9 Vertical - 1.2 2.4
Rated thrust (N)	19 32 64
Stroke (mm)	50 to 800 (50mm pitch)
Overall length (mm)	Horizontal Stroke+201.5 Vertical Stroke+236.5
Maximum outside dimension of body cross-section (mm)	W55×H65
Cable length (m)	Standard: 3.5 / Option: 1.5, 10
Degree of cleanliness	ISO CLASS 3 (ISO14644-1) ^{Note 2}
Intake air (Nℓ/min) ^{Note 3}	80 50 30

Note 1. Positioning repeatability in one direction.
 Note 2. CLASS 10 (0.1 μ m) FED-STD-209D or equivalent when a suction blower is used.
 Note 3. The necessary intake amount varies depending on the use conditions and environment.

Allowable overhang

Lead	Horizontal installation (Unit: mm)			Wall installation (Unit: mm)			Vertical installation (Unit: mm)	
	A	B	C	A	B	C	A	C
Lead 20	1584	324	745	679	303	1505	1.2kg	245
Lead 12	699	104	251	215	87	605	2.4kg	110
Lead 6	1166	159	406	364	126	1073		
Lead 6	551	59	155	123	28	438		
Lead 6	1194	104	294	3kg	259	72	354	
Lead 6	624	31	89	9kg	50	0	154	

Note. Distance from center of slider top to center of gravity of object being carried at a guide service life of 10,000 km.
 Note. Service life is calculated for 600mm stroke models.

Static loading moment

(Unit: N·m)		
MY	MP	MR
30	34	40

Controller

Controller	Operation method
ERCD	Pulse train control / Programming / I/O point trace / Remote command / Operation using RS-232C communication

C5L

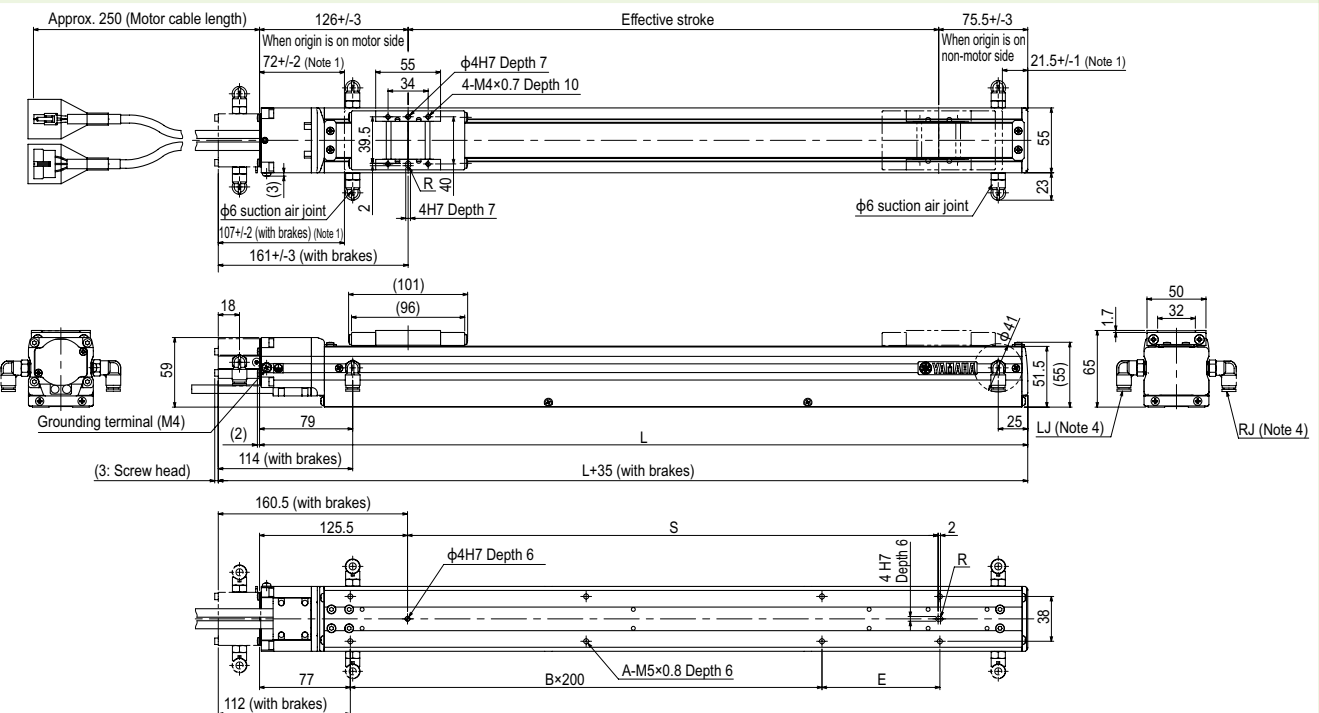

Effective stroke	50	100	150	200	250	300	350	400	450	500	550	600	650	700	750	800
L	251.5	301.5	351.5	401.5	451.5	501.5	551.5	601.5	651.5	701.5	751.5	801.5	851.5	901.5	951.5	1001.5
A	4	4	4	6	6	6	6	8	8	8	8	10	10	10	10	12
B	0	0	0	1	1	1	1	2	2	2	2	3	3	3	3	4
E	100	200	200	100	100	200	200	100	100	200	200	100	100	200	200	100
S	50	100	150	200	250	300	350	400	450	500	550	600	650	700	750	800
Weight (kg) ^{Note 3}	1.7	2.0	2.2	2.5	2.7	3.0	3.2	3.4	3.7	3.9	4.2	4.4	4.7	4.9	5.1	5.4
Maximum speed for each stroke (mm/sec) ^{Note 5}	1000															
Speed setting	-															
Lead 20	90%															
Lead 12	80%															
Lead 6	70%															
Speed setting	-															
	80%															
	70%															
	60%															
	55%															

Note 1. Stop positions are determined by the mechanical stoppers at both ends.
 Note 2. Minimum bend radius of motor cable is R30.
 Note 3. Weight of models with no brake. The weight of brake-attached models is 0.2 kg heavier than the models with no brake shown in the table.
 Note 4. Either right or left can be selected for the installation direction for the $\phi 6$ intake air joint. (The left side is the standard.)
 Note 5. When the stroke is longer than 600mm, resonance of the ball screw may occur depending on the operation conditions (critical speed). In this case, reduce the speed setting on the program by referring to the maximum speeds shown in the table at the left.
 Note 6. External view of C5LH is identical to C5L.

C5LH

- High lead: Lead 20
- Origin on the non-motor side is selectable



Ordering method

C5LH	Model	Lead designation 20: 20mm 12: 12mm 6: 6mm	Brake Note 1 No entry: With no brake BK: With brake	Direction of air coupler installation L: Left (Standard) R: Right	Origin position change None: Standard Z: Non-motor side	Stroke 50 to 800 (50mm pitch)	Cable length Note 2 3L: 3.5m 5L: 5m 10L: 10m 3K/5K/10K (Flexible cable)	TSX	Positioner Note 3 TS-X	Driver: Power supply voltage / Power capacity 105: 100V/100W or less 205: 200V/100W or less	LCD monitor No entry: None L: With LCD	I/O selection NP: NPN PN: PNP CC: CC-Link DN: DeviceNet™ EP: EtherNet/IP™ PT: PROFINET GW: No I/O board Note 4	Battery N: None I: With battery (Absolute) N: None (Incremental)
	SR1-X	05						Controller	Driver: Power capacity 05: 100W or less	Usable for CE No entry: Standard E: CE marking	I/O selection N: NPN P: PNP CC: CC-Link DN: DeviceNet™ PB: PROFIBUS	Battery I: With battery (Absolute) N: None (Incremental)	
	RDV-X	2						Driver	Power supply voltage 2: AC200V		05	Driver: Power capacity 05: 100W or less	

Note 1. The model with a lead of 20mm cannot select specifications with brake (vertical specifications).
 Note 2. The robot cable is standard cable (3L/5L/10L), but can be changed to flexible cable. See P.594 for details on robot cable.
 Note 3. See P.498 for DIN rail mounting bracket.
 Note 4. Select this selection when using the gateway function. For details, see P.60.

Basic specifications

AC servo motor output (W)	30
Repeatability Note 1 (mm)	+/-0.02
Deceleration mechanism	Ball screw ϕ 12 (Class C10)
Ball screw lead (mm)	20 12 6
Maximum speed (mm/sec)	1000 800 400
Maximum payload (kg)	Horizontal: 3 5 9 Vertical: - 1.2 2.4
Rated thrust (N)	19 32 64
Stroke (mm)	50 to 800 (50mm pitch)
Overall length (mm)	Horizontal: Stroke+201.5 Vertical: Stroke+236.5
Maximum outside dimension of body cross-section (mm)	W55×H65
Cable length (m)	Standard: 3.5 / Option: 5, 10
Degree of cleanliness	ISO CLASS 3 (ISO14644-1) Note 2
Intake air (Nl/min) Note 3	80 50 30

Note 1. Positioning repeatability in one direction.
 Note 2. CLASS 10 (0.1 μ m) FED-STD-209D or equivalent when a suction blower is used.
 Note 3. The necessary intake amount varies depending on the use conditions and environment.

Allowable overhang Note

	Horizontal installation (Unit: mm)	Wall installation (Unit: mm)	Vertical installation (Unit: mm)
Lead 20	A B C	A B C	A C
1kg	1099 324 645	602 303 950	1.2kg 240 239
3kg	488 104 241	197 87 432	2.4kg 109 110
2kg	916 159 398	347 141 800	
5kg	436 60 152	5kg 119 44 355	
3kg	1194 105 294	3kg 259 87 950	
9kg	624 31 89	9kg 50 15 385	

Note. Distance from center of slider top to center of gravity of object being carried at a guide service life of 10,000 km.
 Note. Service life is calculated for 600mm stroke models.

Static loading moment

	(Unit: N·m)
MY	MP MR
30	34 40

Controller

Controller	Operation method
SR1-X05 RCX221/222 RCX240/340	Programming / I/O point trace / Remote command / Operation using RS-232C communication
TS-X105	I/O point trace / Remote command
TS-X205	
RDV-X205	Pulse train control

C5LH

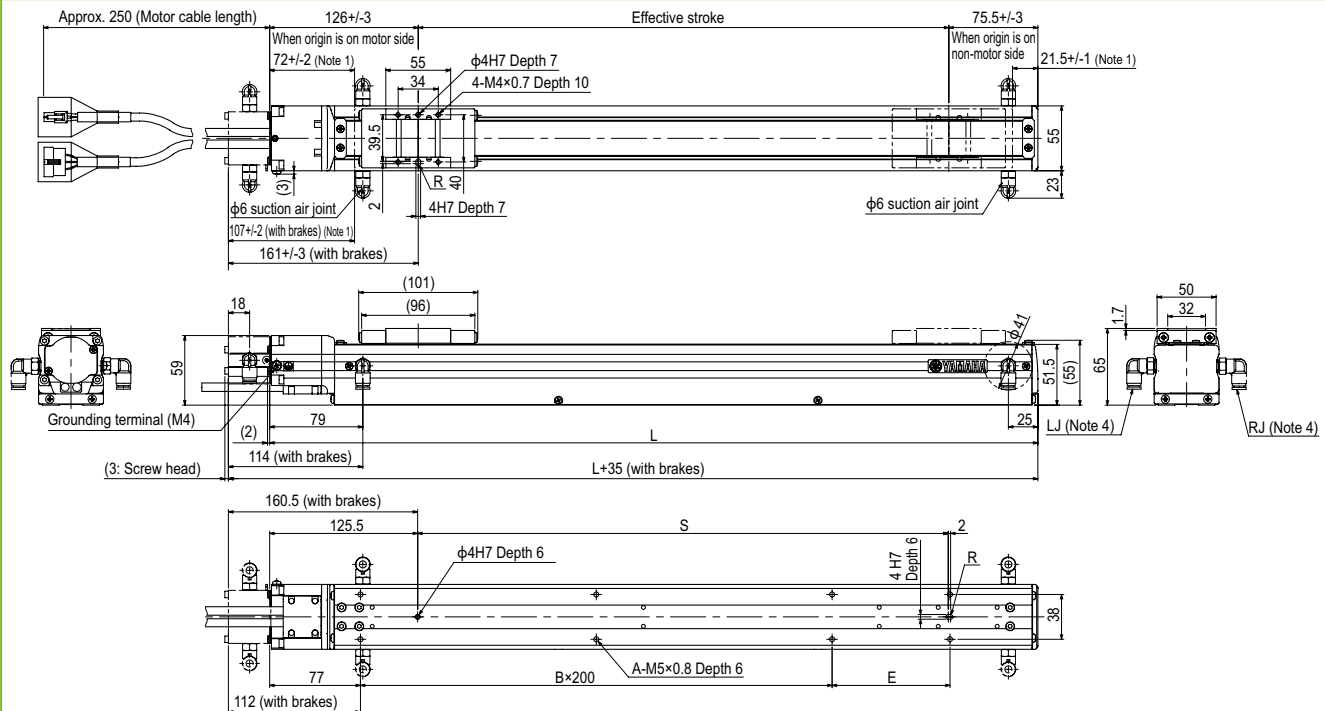

Effective stroke	50	100	150	200	250	300	350	400	450	500	550	600	650	700	750	800
L	251.5	301.5	351.5	401.5	451.5	501.5	551.5	601.5	651.5	701.5	751.5	801.5	851.5	901.5	951.5	1001.5
A	4	4	4	6	6	6	6	8	8	8	8	10	10	10	10	12
B	0	0	0	1	1	1	1	2	2	2	2	3	3	3	3	4
E	100	200	200	100	100	200	200	100	100	200	200	100	100	200	200	100
S	50	100	150	200	250	300	350	400	450	500	550	600	650	700	750	800
Weight (kg) Note 3	1.7	2.0	2.2	2.5	2.7	3.0	3.2	3.4	3.7	3.9	4.2	4.4	4.7	4.9	5.1	5.4
Maximum speed for each stroke (mm/sec)	1000															
Lead 20 Speed setting	900 800 700															
Lead 12 Speed setting	90% 80% 70%															
Lead 6 Speed setting	800 400															
	640 560 480 440															
	320 280 240 220															
	80% 70% 60% 55%															

Note 1. Stop positions are determined by the mechanical stoppers at both ends.
 Note 2. Minimum bend radius of motor cable is R30.
 Note 3. Weight of models with no brake. The weight of brake-attached models is 0.2 kg heavier than the models with no brake shown in the table.
 Note 4. Either right or left can be selected for the installation direction for the ϕ 6 intake air joint. (The left side is the standard.)
 Note 5. When the stroke is longer than 600mm, resonance of the ball screw may occur depending on the operation conditions (critical speed). In this case, reduce the speed setting on the program by referring to the maximum speeds shown in the table at the left.
 Note 6. External view of C5LH is identical to C5L.

C6L

- High lead: Lead 20
- Origin on the non-motor side is selectable

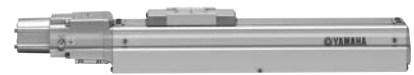

Ordering method

C6L

Model	Lead designation 20: 20mm 12: 12mm 6: 6mm	Brake Note 1 No entry: With no brake BK: With brake	Direction of air coupler installation L: Left (Standard) R: Right	Origin position change None: Standard Z: Non-motor side	Stroke 50 to 800 (50mm pitch)	Cable length Note 2 3L: 3.5m 5L: 5m 10L: 10m 3K/5K/10K (Flexible cable)
--------------	---	--	--	--	---	--

TSX

Positioner Note 3 TS-X	Driver: Power supply voltage / Power capacity 105: 100V/100W or less 205: 200V/100W or less	LCD monitor No entry: None L: With LCD	I/O selection NP: NPN PN: PNP CC: CC-Link DN: DeviceNet™ EP: EtherNet/IP™ PT: PROFINET GW: No I/O board Note 4	Battery 3: With battery (Absolute) N: None (Incremental)
----------------------------------	--	---	--	---

SR1-X

Controller 05	Driver: Power capacity 05: 100W or less	Usable for CE No entry: Standard E: CE marking	I/O selection N: NPN P: PNP CC: CC-Link DN: DeviceNet™ PB: PROFIBUS	Battery 3: With battery (Absolute) N: None (Incremental)
-------------------------	---	---	---	---

RDV-X

Driver 2	Power supply voltage 2: AC200V	Driver: Power capacity 05: 100W or less	Regenerative unit RBR1
--------------------	--	---	----------------------------------

Note 1. The model with a lead of 20mm cannot select specifications with brake (vertical specifications).
 Note 2. The robot cable is standard cable (3L/5L/10L), but can be changed to flexible cable. See P.594 for details on robot cable.
 Note 3. See P.498 for DIN rail mounting bracket.
 Note 4. Select this selection when using the gateway function. For details, see P.60.

Basic specifications

AC servo motor output (W)	60
Repeatability Note 1 (mm)	+/-0.02
Deceleration mechanism	Ball screw ϕ 12 (Class C10)
Ball screw lead (mm)	20 12 6
Maximum speed (mm/sec)	1000 800 400
Maximum payload (kg)	Horizontal 10 12 30 Vertical - 4 8
Rated thrust (N)	51 85 170
Stroke (mm)	50 to 800 (50mm pitch)
Overall length (mm)	Horizontal Stroke+247.5 Vertical Stroke+282.5
Maximum outside dimension of body cross-section (mm)	W65×H65
Cable length (m)	Standard: 3.5 / Option: 5, 10
Degree of cleanliness	ISO CLASS 3 (ISO14644-1) Note 2
Intake air (Nl/min) Note 3	80 50 30

Note 1. Positioning repeatability in one direction.
 Note 2. CLASS 10 (0.1 μ m) FED-STD-209D or equivalent when a suction blower is used.
 Note 3. The necessary intake amount varies depending on the use conditions and environment.

Allowable overhang

Lead	Horizontal installation (Unit: mm)			Wall installation (Unit: mm)			Vertical installation (Unit: mm)		
	A	B	C	A	B	C	A	B	C
Lead 20	2kg 433	192	295	2kg 300	174	365	1kg 353	351	
	6kg 145	59	104	6kg 83	44	105	2kg 163	164	
	10kg 110	33	75	10kg 43	18	71	4kg 68	70	
Lead 12	3kg 622	125	336	3kg 291	96	317	2kg 169	170	
	8kg 271	41	121	8kg 87	13	110	4kg 71	73	
	12kg 214	24	76	12kg 41	0	126	8kg 21	24	
Lead 6	5kg 692	73	236	5kg 202	45	237			
	10kg 372	33	109	10kg 70	5	97			
	30kg 157	0	25	30kg 0	0	0			

Note. Distance from center of slider top to center of gravity of object being carried at a guide service life of 10,000 km.

Note. Service life is calculated for 600mm stroke models.

Static loading moment

(Unit: N·m)		
MY	MP	MR
35	40	50

Controller

Controller	Operation method
SR1-X05 RCX221/222 RCX240/340	Programming / I/O point trace / Remote command / Operation using RS-232C communication
TS-X105	I/O point trace / Remote command
TS-X205	I/O point trace / Remote command
RDV-X205-RBR1	Pulse train control

C6L

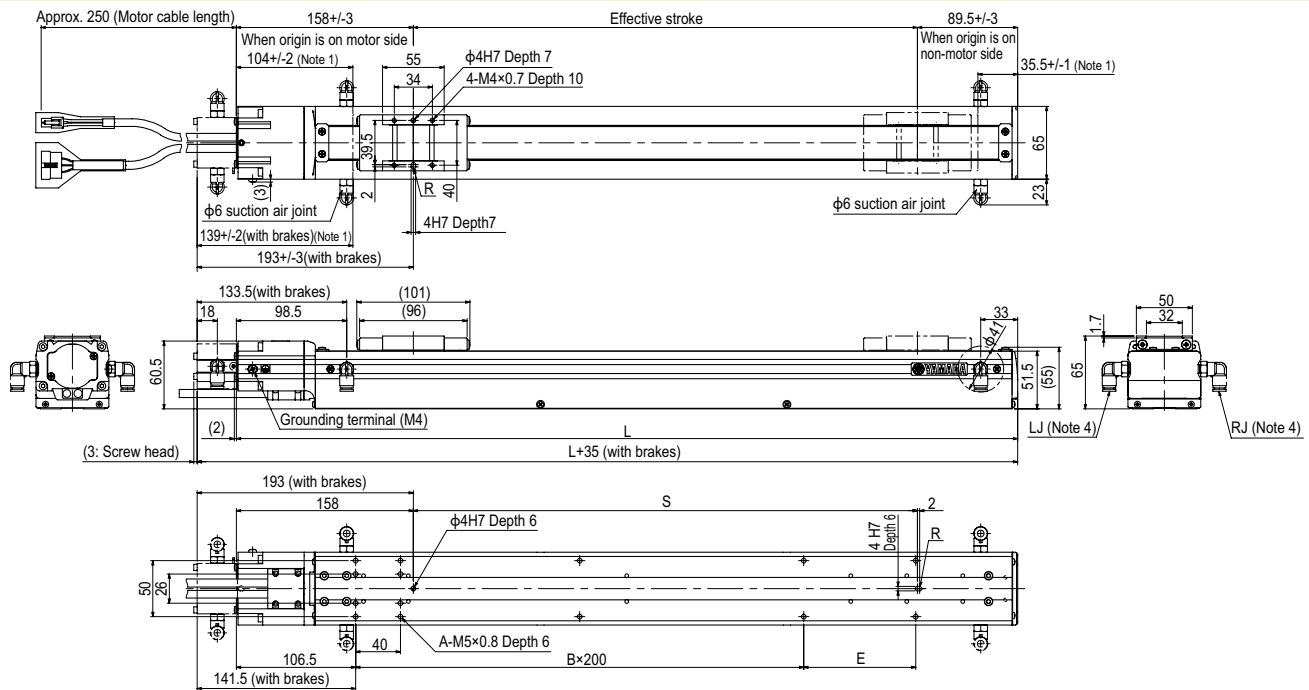

Effective stroke	50	100	150	200	250	300	350	400	450	500	550	600	650	700	750	800
L	297.5	347.5	397.5	447.5	497.5	547.5	597.5	647.5	697.5	747.5	797.5	847.5	897.5	947.5	997.5	1047.5
A	10	10	10	12	12	12	12	14	14	14	14	16	16	16	16	18
B	0	0	0	1	1	1	1	2	2	2	2	3	3	3	3	4
E	150	200	200	100	100	200	200	100	100	200	200	100	100	200	200	100
S	50	100	150	200	250	300	350	400	450	500	550	600	650	700	750	800
Weight (kg) Note 3	2.6	2.9	3.1	3.4	3.7	4.0	4.3	4.6	4.9	5.2	5.4	5.7	6.0	6.3	6.6	6.8
Maximum speed for each stroke Note 5 (mm/sec)	Lead 20	1000														
	Speed setting	-														
	Lead 12	800														
	Lead 6	400														
Speed setting		90%														
		80%														
		70%														
	680															
	600															
	520															
	480															
	340															
	300															
	260															
	240															
	85%															
	75%															
	65%															
	60%															

Note 1. Stop positions are determined by the mechanical stoppers at both ends.
 Note 2. Minimum bend radius of motor cable is R30.
 Note 3. Weight of models with no brake. The weight of brake-attached models is 0.2 kg heavier than the models with no brake shown in the table.
 Note 4. Either right or left can be selected for the installation direction for the ϕ 6 intake air joint. (The left side is the standard.)
 Note 5. When the stroke is longer than 600mm, resonance of the ball screw may occur depending on the operation conditions (critical speed). In this case, reduce the speed setting on the program by referring to the maximum speeds shown in the table at the left.

C8L

Origin on the non-motor side is selectable

Ordering method

C8L	Model	Lead 20: 20mm 10: 10mm 5: 5mm	Brake No entry: With no brake BK: With brake	Option Origin position change None: Standard Z: Non-motor side	Stroke 150 to 1050 (50mm pitch)	Cable length ^{Note 1} 3L: 3.5m 5L: 5m 10L: 10m 3K/5K/10K (Flexible cable)	TSX	Positioner ^{Note 2} TS-X	Driver: Power-supply voltage / Power capacity 105: 100V/100W or less 205: 200V/100W or less	LCD monitor No entry: None L: With LCD	I/O selection NP: NPN PN: PNP CC: CC-Link DN: DeviceNet™ EP: EtherNet/IP™ PT: PROFINET GW: No I/O board ^{Note 3}	Battery B: With battery (Absolute) N: None (Incremental)
	SR1-X	Controller	05	Driver: Power capacity 05: 100W or less	Usable for CE No entry: Standard E: CE marking	I/O selection N: NPN P: PNP CC: CC-Link DN: DeviceNet™ PB: PROFIBUS	Battery B: With battery (Absolute) N: None (Incremental)					
	RDV-X	Driver	2	Power-supply voltage 2: AC200V	Driver: Power capacity 05: 100W or less	RBR1	Regenerative unit					

Note 1. The robot cable is standard cable (3L/5L/10L), but can be changed to flexible cable. See P.594 for details on robot cable.
 Note 2. See P.498 for DIN rail mounting bracket.
 Note 3. Select this selection when using the gateway function. For details, see P.60.

Basic specifications

AC servo motor output (W)	100
Repeatability ^{Note 1} (mm)	+/-0.01
Deceleration mechanism	Ball screw (Class C7)
Ball screw lead (mm)	20 10 5
Maximum speed ^{Note 2} (mm/sec)	1000 600 300
Maximum payload (kg)	Horizontal 20 40 50 Vertical 4 8 16
Rated thrust (N)	84 169 339
Stroke (mm)	150 to 1050 (50mm pitch)
Overall length (mm)	Horizontal Stroke+325 Vertical Stroke+360
Maximum outside dimension of body cross-section (mm)	W80 x H75
Cable length (m)	Standard: 3.5 / Option: 5, 10
Degree of cleanliness	CLASS 10 ^{Note 3}
Intake air (Nl/min)	30 to 90 ^{Note 4}

Note 1. Positioning repeatability in one direction.
 Note 2. When the stroke is longer than 700mm, resonance of the ball screw may occur depending on the operation conditions (critical speed). In this case, reduce the speed setting on the program by referring to the maximum speeds shown in the table below.
 Note 3. Per 1cf (0.1um base), when suction blower is used.
 Note 4. The necessary intake amount varies depending on the use conditions and environment.

Allowable overhang

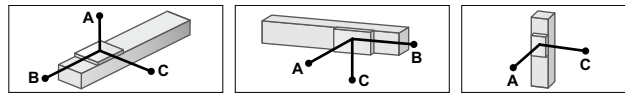

Lead	Horizontal installation (Unit: mm)			Wall installation (Unit: mm)			Vertical installation (Unit: mm)		
	A	B	C	A	B	C	A	C	
Lead 20	5kg	259	122	179	5kg	147	100	220	
	10kg	149	55	89	10kg	53	32	97	
	15kg	100	33	56	15kg	17	10	39	
	20kg	95	22	41	20kg	0	0	0	
Lead 10	10kg	251	61	130	10kg	87	41	197	
	20kg	127	25	55	20kg	10	4	37	
	30kg	90	14	31	30kg	0	0	0	
	40kg	69	8	18	40kg	0	0	0	
Lead 5	20kg	256	29	76	20kg	24	9	152	
	30kg	188	16	43	30kg	0	0	0	
	40kg	96	10	28	40kg	0	0	0	
	50kg	33	6	18	50kg	0	0	0	

Note. Distance from center of slider top to center of gravity of object being carried at a guide service life of 10,000 km.

Static loading moment

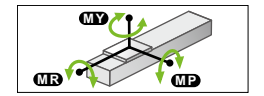

(Unit: N·m)		
MY	MP	MR
70	95	110

Controller

Controller	Operation method
SR1-X05 RCX221/222 RCX240/340	Programming / I/O point trace / Remote command / Operation using RS-232C communication
TS-X105	I/O point trace / Remote command
TS-X205	Remote command
RDV-X205-RBR1	Pulse train control

C8L

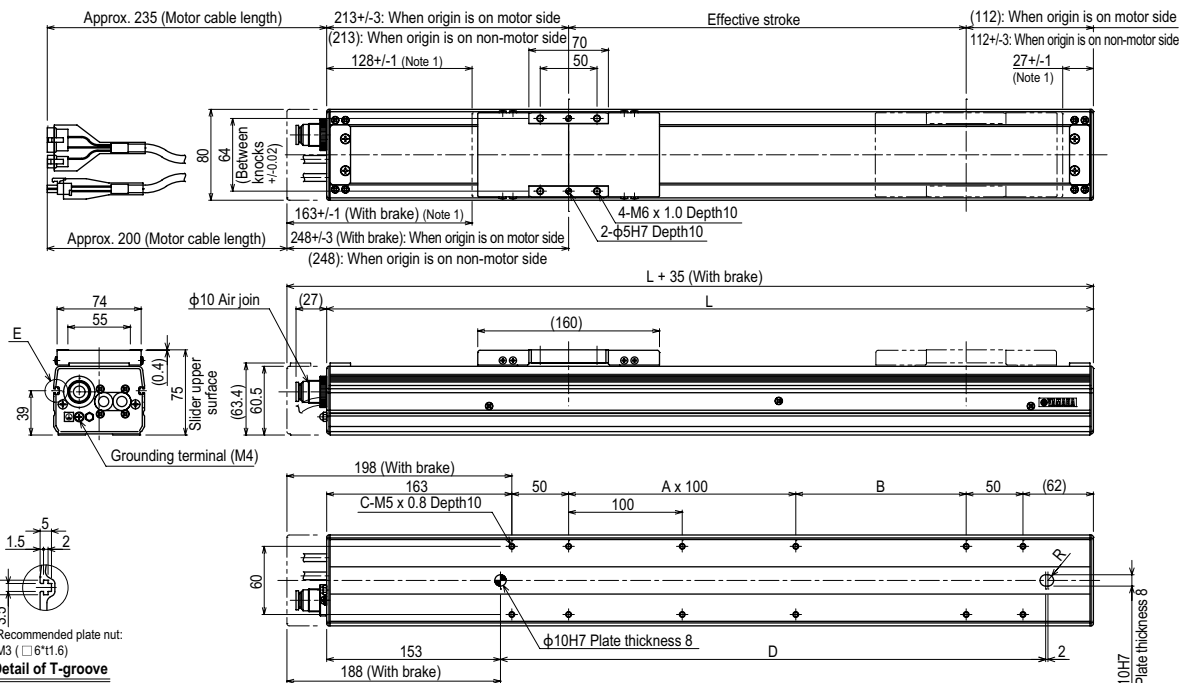

E: Detail of T-groove
 Note: Recommended plate nut: M3 (□6*11.6)

Effective stroke	150	200	250	300	350	400	450	500	550	600	650	700	750	800	850	900	950	1000	1050	
L	475	525	575	625	675	725	775	825	875	925	975	1025	1075	1125	1175	1225	1275	1325	1375	
A	0	1	1	2	2	3	3	4	4	5	5	6	6	7	7	8	8	9	9	
B	150	100	150	100	150	100	150	100	150	100	150	100	150	100	150	100	150	100	150	
C	8	10	10	12	12	14	14	16	16	18	18	20	20	22	22	24	24	26	26	
D	280	330	380	430	480	530	580	630	680	730	780	830	880	930	980	1030	1080	1130	1180	
Weight (kg) ^{Note 3}	3.9	4.2	4.5	4.8	5.1	5.4	5.7	6.0	6.4	6.7	7.0	7.3	7.6	7.9	8.2	8.5	8.8	9.2	9.5	
Maximum speed ^{Note 4} (mm/sec)	1000																			
	Speed setting	-																		
	Lead 10	600																		
	Lead 5	300																		
Speed setting	-																			
	85% 75% 65% 60% 55% 50% 45% 40%																			

Note 1. Stop positions are determined by the mechanical stoppers at both ends.
 Note 2. Minimum bend radius of motor cable is R50.
 Note 3. Weight of models with no brake. The weight of brake-attached models is 0.3 kg heavier than the models with no brake shown in the table.
 Note 4. When the stroke is longer than 700mm, resonance of the ball screw may occur depending on the operation conditions (critical speed). In this case, reduce the speed setting on the program by referring to the maximum speeds shown in the table at the left.

C8LH

Origin on the non-motor side is selectable

Ordering method

C8LH

Model	Lead	Option	Stroke	Cable length ^{Note 1}	TSX	SR1-X	RDV-X	Battery
	20: 20mm 10: 10mm 5: 5mm	Origin position change None: Standard Z: Non-motor side	150 to 1050 (50mm pitch)	3L: 3.5m 5L: 5m 10L: 10m 3K/5K/10K (Flexible cable)	Positioner ^{Note 2} TS-X Driver: Power supply voltage / Power capacity 105: 100V/100W or less 205: 200V/100W or less LCD monitor No entry: None L: With LCD	Controller 05 Driver: Power capacity 05: 100W or less Usable for CE No entry: Standard E: CE marking	Driver 2 Power supply voltage 2: AC200V Driver: Power capacity 05: 100W or less Regenerative unit RBR1	Battery B: With battery (Absolute) N: None (Incremental) I/O selection NP: NPN PN: PNP CC: CC-Link DN: DeviceNet™ EP: EtherNet/IP™ PT: PROFINET GW: No I/O board ^{Note 3}

Note 1. The robot cable is standard cable (3L/5L/10L), but can be changed to flexible cable. See P.594 for details on robot cable.
 Note 2. See P.498 for DIN rail mounting bracket.
 Note 3. Select this selection when using the gateway function. For details, see P.60.

Basic specifications

AC servo motor output (W)	100
Repeatability ^{Note 1} (mm)	+/-0.01
Deceleration mechanism	Ball screw (Class C7)
Ball screw lead (mm)	20 10 5
Maximum speed ^{Note 2} (mm/sec)	1000 600 300
Maximum payload (kg)	Horizontal 30 60 80
Rated thrust (N)	84 169 339
Stroke (mm)	150 to 1050 (50mm pitch)
Overall length (mm)	Stroke+389
Maximum outside dimension of body cross-section (mm)	W80 x H75
Cable length (m)	Standard: 3.5 / Option: 5, 10
Degree of cleanliness	CLASS 10 ^{Note 3}
Intake air (N ₂ /min)	30 to 90 ^{Note 4}

Note 1. Positioning repeatability in one direction.
 Note 2. When the stroke is longer than 650mm, resonance of the ball screw may occur depending on the operation conditions (critical speed). In this case, reduce the speed setting on the program by referring to the maximum speeds shown in the table below.
 Note 3. Per 1cf (0.1um base), when suction blower is used.
 Note 4. The necessary intake amount varies depending on the use conditions and environment.

Allowable overhang ^{Note}

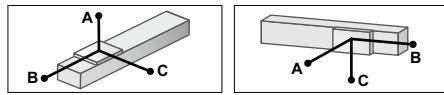

	Horizontal installation (Unit: mm)			Wall installation (Unit: mm)		
	A	B	C	A	B	C
Lead 20	10kg	687	274	200	163	225
	20kg	401	125	92	56	76
	30kg	338	76	57	20	27
Lead 10	20kg	622	137	111	74	90
	40kg	472	57	47	8	11
	60kg	375	30	25	-	-
Lead 5	20kg	1087	148	127	89	104
	40kg	844	63	54	15	18
	60kg	707	34	29	-	-
	80kg	594	20	17	-	-

Note. Distance from center of slider top to center of gravity of object being carried at a guide service life of 10,000 km.

Static loading moment

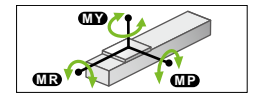

(Unit: N·m)		
MY	MP	MR
128	163	143

Controller

Controller	Operation method
SR1-X05 RCX221/222 RCX240/340	Programming / I/O point trace / Remote command / Operation using RS-232C communication
TS-X105	I/O point trace / Remote command
TS-X205	
RDV-X205-RBR1	Pulse train control

C8LH

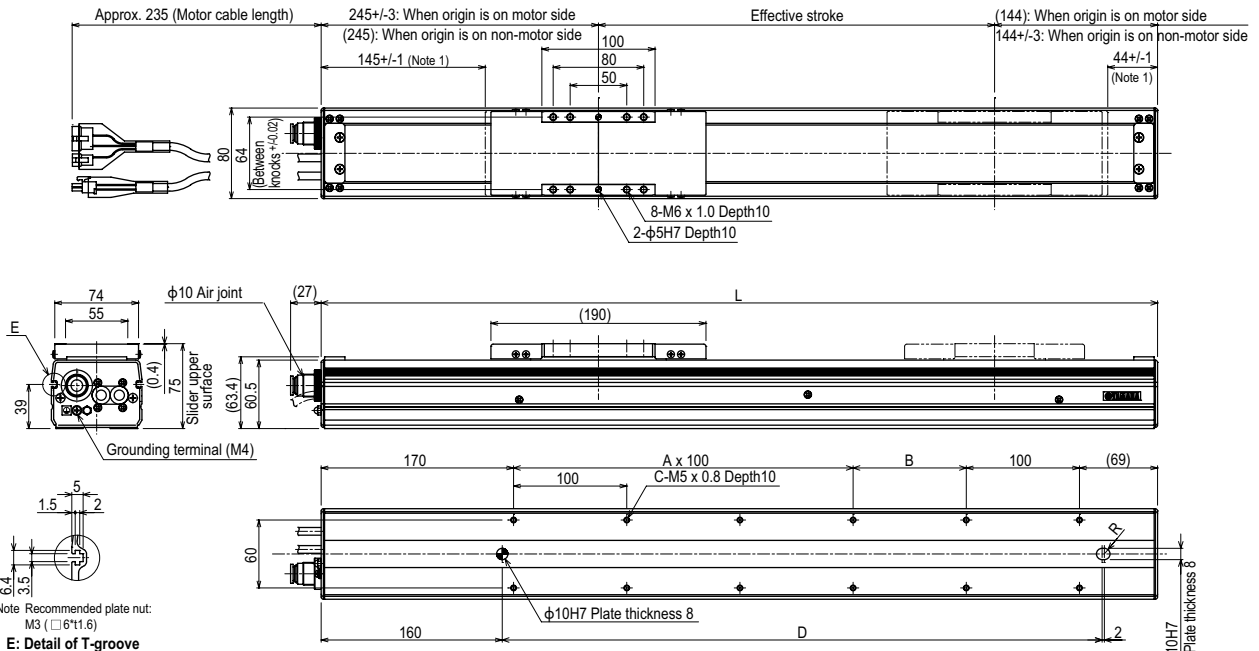

Effective stroke	150	200	250	300	350	400	450	500	550	600	650	700	750	800	850	900	950	1000	1050
L	539	589	639	689	739	789	839	889	939	989	1039	1089	1139	1189	1239	1289	1339	1389	1439
A	1	1	2	2	3	3	4	4	5	5	6	6	7	7	8	8	9	9	10
B	100	150	100	150	100	150	100	150	100	150	100	150	100	150	100	150	100	150	100
C	8	8	10	10	12	12	14	14	16	16	18	18	20	20	22	22	24	24	26
D	330	380	430	480	530	580	630	680	730	780	830	880	930	980	1030	1080	1130	1180	1230
Weight (kg)	4.7	5.0	5.3	5.6	5.9	6.2	6.6	6.9	7.2	7.5	7.8	8.1	8.4	8.7	9.0	9.3	9.7	10.0	10.3
Maximum speed ^{Note 3} (mm/sec)	Lead 20																		
	Speed setting																		
	Lead 10																		
	Lead 5																		
Speed setting	-																		
	-																		

Note 1. Stop positions are determined by the mechanical stoppers at both ends.
 Note 2. Minimum bend radius of motor cable is R50.
 Note 3. When the stroke is longer than 650mm, resonance of the ball screw may occur depending on the operation conditions (critical speed). In this case, reduce the speed setting on the program by referring to the maximum speeds shown in the table at the left.

Articulated robots
YA
Linear conveyor modules
LCM100
Compact single-axis robots
TRANSEVO
Single-axis robots
FLIP-X
Linear motor single-axis robots
PHASER
Cartesian robots
XX-X
SCARA robots
YK-X
Pick & place robots
YP-X
CLEAN
CONTROLLER INFORMATION
Single-axis
Cartesian
SCARA

C10

Origin on the non-motor side is selectable: Lead 20 • 10



Ordering method

C10

Model	Lead	Brake	Option	Stroke	Cable length ^{Note 2}
	20: 20mm 10: 10mm 5: 5mm	No entry: With no brake BK: With brake	Origin position change None: Standard Z: Non-motor side ^{Note 1}	150 to 1050 (50mm pitch)	3L: 3.5m 5L: 5m 10L: 10m 3K/5K/10K (Flexible cable)

TSX

Positioner ^{Note 3}	Driver: Power-supply voltage / Power capacity	Regenerative unit	LCD monitor	I/O selection	Battery
TS-X	105: 100V/100W or less 205: 200V/100W or less	No entry: None R: With RGT	No entry: None L: With LCD	NP: NPN PN: PNP CC: CC-Link DN: DeviceNet™ EP: EtherNet/IP™ PT: PROFINET GW: No I/O board ^{Note 4}	B: With battery (Absolute) N: None (Incremental)

SR1-X

Controller	Driver: Power capacity	Usable for CE	Regenerative unit	I/O selection	Battery
05	05: 100W or less	No entry: Standard E: CE marking	No entry: None R: With RGT	N: NPN P: PNP CC: CC-Link DN: DeviceNet™ PB: PROFIBUS	B: With battery (Absolute) N: None (Incremental)

RDV-X

Driver	Power-supply voltage	Driver: Power capacity	Regenerative unit
2	2: AC200V	05: 100W or less	RBR1

- Note 1. If selecting 5mm lead specifications then the origin point cannot be changed to the non-motor side.
 Note 2. The robot cable is standard cable (3L/5L/10L), but can be changed to flexible cable. See P.594 for details on robot cable.
 Note 3. See P.498 for DIN rail mounting bracket.
 Note 4. Select this selection when using the gateway function. For details, see P.60.

Basic specifications

AC servo motor output (W)	100
Repeatability ^{Note 1} (mm)	+/-0.01
Deceleration mechanism	Ball screw (Class C7)
Ball screw lead (mm)	20 10 5
Maximum speed (mm/sec)	1000 500 250
Maximum payload (kg)	Horizontal 20 40 60 Vertical 4 10 20
Rated thrust (N)	84 169 339
Stroke (mm)	150 to 1050 (50mm pitch)
Overall length (mm)	Horizontal Stroke+283 Vertical Stroke+313
Maximum outside dimension of body cross-section (mm)	W104 x H85
Cable length (m)	Standard: 3.5 / Option: 5, 10
Degree of cleanliness	CLASS 10 ^{Note 3}
Intake air (Nl/min)	30 to 90 ^{Note 4}

- Note 1. Positioning repeatability in one direction.
 Note 2. When the stroke is longer than 750mm, resonance of the ball screw may occur depending on the operation conditions (critical speed). In this case, reduce the speed setting on the program by referring to the maximum speeds shown in the table below.
 Note 3. Per 1cf (0.1um base), when suction blower is used.
 Note 4. The necessary intake amount varies depending on the use conditions and environment.

Allowable overhang^{Note}

Horizontal installation (Unit: mm)	Wall installation (Unit: mm)			Vertical installation (Unit: mm)				
	A	B	C	Lead 20	Lead 10			
Lead 20	5kg	1875	530	5kg	496	451	1826	
	10kg	1079	247	242	10kg	218	168	1002
	20kg	628	106	107	20kg	78	27	497
Lead 10	15kg	765	156	164	10kg	230	170	1036
	30kg	425	62	66	20kg	80	29	506
	40kg	350	38	42	30kg	30	0	311
Lead 5	30kg	960	63	68	10kg	234	170	2716
	50kg	565	25	28	20kg	82	29	1206
	60kg	470	16	17	30kg	31	0	711

Note. Distance from center of slider top to center of gravity of object being carried at a guide service life of 10,000 km.

Static loading moment

(Unit: N·m)		
MY	MP	MR
119	119	105

Controller

Controller	Operation method
SR1-X05 ^{Note}	Programming / I/O point trace / Remote command / Operation using RS-232C communication
TS-X105 ^{Note}	I/O point trace / Remote command
TS-X205 ^{Note}	I/O point trace / Remote command
RDV-X205-RBR1	Pulse train control

Note. Regenerative unit is required when the models used vertically and with 700mm or larger stroke.

C10

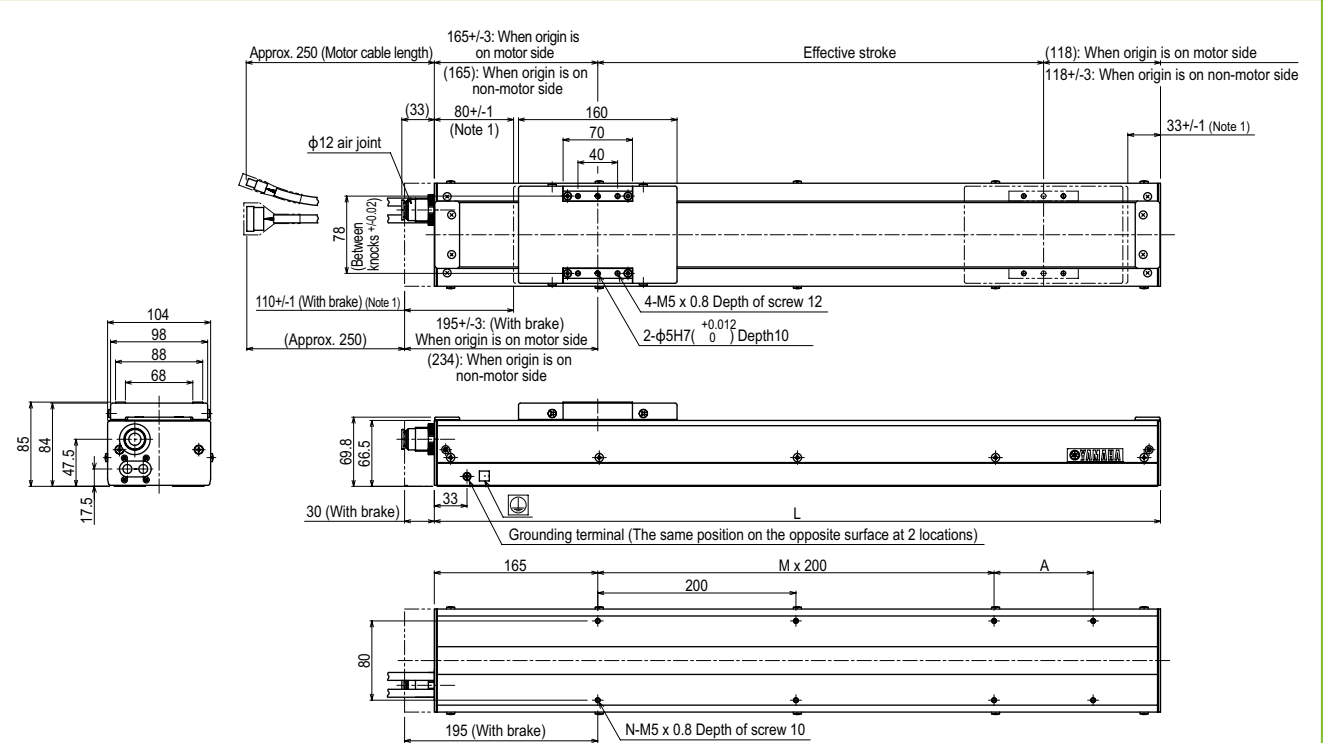

Effective stroke	150	200	250	300	350	400	450	500	550	600	650	700	750	800	850	900	950	1000	1050	
L	433	483	533	583	633	683	733	783	833	883	933	983	1033	1083	1133	1183	1233	1283	1333	
A	200	50	100	150	200	50	100	150	200	50	100	150	200	50	100	150	200	50	100	
M	0	1	1	1	1	2	2	2	2	3	3	3	3	4	4	4	4	5	5	
N	4	6	6	6	6	8	8	8	8	10	10	10	10	12	12	12	12	14	14	
Weight (kg) ^{Note 3}	4.4	5.0	5.5	6.1	6.7	7.3	7.8	8.4	9.0	9.6	10.1	10.7	11.3	11.9	12.4	13.0	13.6	14.2	14.7	
Maximum speed (mm/sec) ^{Note 4}	Lead 20	1000																		
	Lead 10	500																		
	Lead 5	250																		
Speed setting	95% 95% 75% 75% 60% 60% 50%																			

- Note 1. Stop positions are determined by the mechanical stoppers at both ends.
 Note 2. Minimum bend radius of motor cable is R50.
 Note 3. Weight of models with no brake. The weight of brake-attached models is 0.4 kg heavier than the models with no brake shown in the table.

Note 4. When the stroke is longer than 750mm, resonance of the ball screw may occur depending on the operation conditions (critical speed). In this case, reduce the speed setting on the program by referring to the maximum speeds shown in the table at the left.

C14

Origin on the non-motor side is selectable



Ordering method

C14					TSX					SR1-X					RDV-X							
Model	Lead	Brake	Option	Stroke	Cable length	Positioner	Driver: Power-supply voltage / Power capacity	Regenerative unit	LCD monitor	I/O selection	Battery	Controller	Driver: Power capacity	Usable for CE	Regenerative unit	I/O selection	Battery	Driver	Power-supply voltage	Driver: Power capacity	Regenerative unit	
	20: 20mm 10: 10mm 5: 5mm	No entry: With no brake BK: With brake	Origin position change None: Standard Z: Non-motor side	150 to 1050 (50mm pitch)	3L: 3.5m 5L: 5m 10L: 10m 3K/5K/10K (Flexible cable)	TS-X	105: 100V/100W or less 205: 200V/100W or less	No entry: None R: With RGT	No entry: None L: With LCD	NP: NPN PN: PNP CC: CC-Link DN: DeviceNet™ EP: EtherNet/IP™ PT: PROFINET GW: No I/O board	B: With battery (Absolute) N: None (Incremental)	SR1-X	05: 100W or less	No entry: Standard E: CE marking	No entry: None R: With RG1	N: NPN P: PNP CC: CC-Link DN: DeviceNet™ PB: PROFIBUS	B: With battery (Absolute) N: None (Incremental)	RDV-X	2: AC200V	05: 100W or less	RBR1	

Note 1. The robot cable is standard cable (3L/5L/10L), but can be changed to flexible cable. See P.594 for details on robot cable.
 Note 2. See P.498 for DIN rail mounting bracket.
 Note 3. Select this selection when using the gateway function. For details, see P.60.

Basic specifications

AC servo motor output (W)	100
Repeatability (mm)	+/-0.01
Deceleration mechanism	Ball screw (Class C7)
Ball screw lead (mm)	20 10 5
Maximum speed (mm/sec)	1000 500 250
Maximum payload (kg)	Horizontal 30 55 80 Vertical 4 10 20
Rated thrust (N)	84 169 339
Stroke (mm)	150 to 1050 (50mm pitch)
Overall length (mm)	Horizontal Stroke+285 Vertical Stroke+315
Maximum outside dimension of body cross-section (mm)	W136 x H96
Cable length (m)	Standard: 3.5 / Option: 5, 10
Degree of cleanliness	CLASS 10
Intake air (Nl/min)	30 to 90

Note 1. Positioning repeatability in one direction.
 Note 2. When the stroke is longer than 750mm, resonance of the ball screw may occur depending on the operation conditions (critical speed). In this case, reduce the speed setting on the program by referring to the maximum speeds shown in the table below.
 Note 3. Per 1cf (0.1um base), when suction blower is used.
 Note 4. The necessary intake amount varies depending on the use conditions and environment.

Allowable overhang

	Horizontal installation (Unit: mm)			Wall installation (Unit: mm)			Vertical installation (Unit: mm)			
	A	B	C	A	B	C	A	C		
Lead 20	5kg	2127	1384	968	1047	968	1553	1kg	600	600
	15kg	1177	459	425	387	264	748	2kg	1200	1200
	30kg	1247	242	291	206	97	633	4kg	1141	885
Lead 10	20kg	1120	349	353	299	180	658	8kg	1216	943
	40kg	857	179	215	127	49	363	10kg	621	482
	55kg	932	138	182	79	16	296	15kg	574	445
Lead 5	50kg	2017	250	335	233	103	1033	20kg	370	287
	60kg	1477	134	192	75	13	433	20kg	268	208
	80kg	1452	106	157	35	0	242			

Note. Distance from center of slider top to center of gravity of object being carried at a guide service life of 10,000 km.

Static loading moment

(Unit: N·m)		
MY	MP	MR
232	233	204

Controller

Controller	Operation method
SR1-X-05	Programming / I/O point trace / Remote command / Operation using RS-232C communication
RCX21/222 / RCX240/340	Remote command / Operation using RS-232C communication
TS-X105	I/O point trace / Remote command
TS-X205	Remote command
RDV-X205-RBR1	Pulse train control

Note. Regenerative unit is required when the models used vertically and with 700mm or larger stroke.

C14

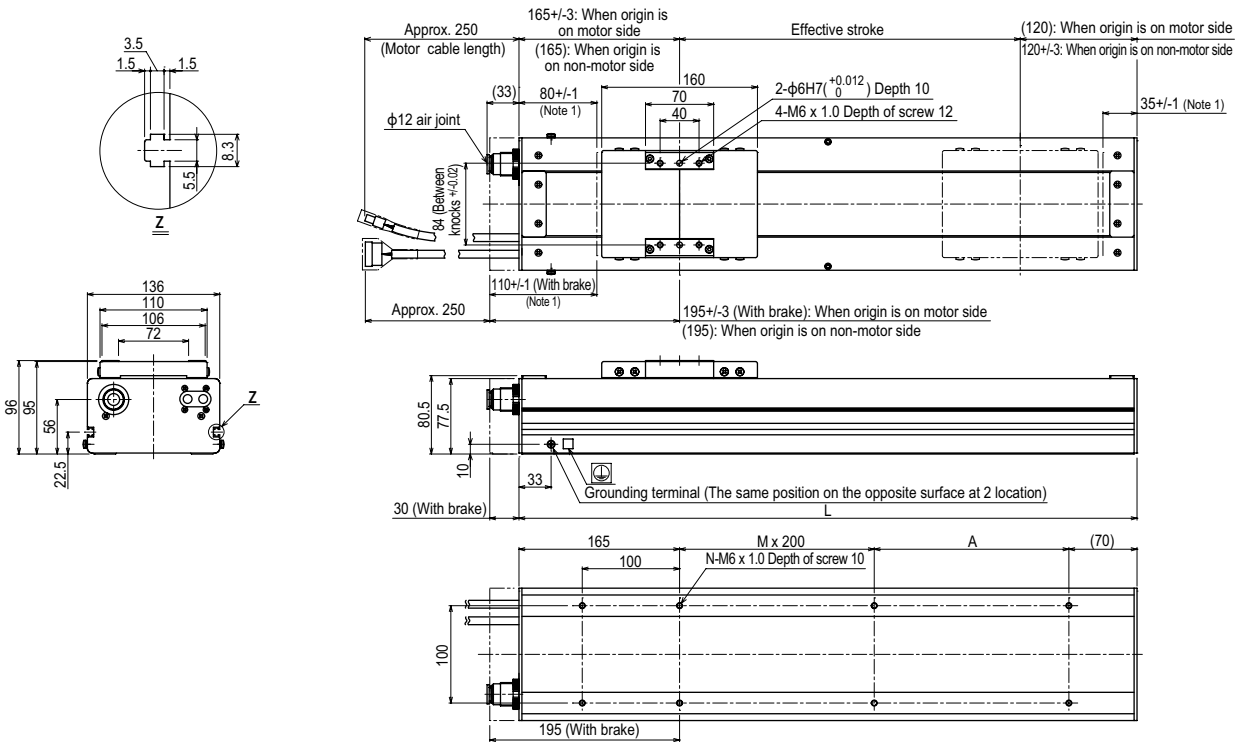

Effective stroke	150	200	250	300	350	400	450	500	550	600	650	700	750	800	850	900	950	1000	1050
L	435	485	535	585	635	685	735	785	835	885	935	985	1035	1085	1135	1185	1235	1285	1335
A	200	50	100	150	200	50	100	150	200	50	100	150	200	50	100	150	200	50	100
M	0	1	1	1	1	2	2	2	2	3	3	3	3	4	4	4	4	5	5
N	6	8	8	8	8	10	10	10	10	12	12	12	12	14	14	14	14	16	16
Weight (kg)	9.2	9.9	10.5	11.2	11.7	12.4	13.0	13.7	14.3	15.0	15.5	16.2	16.8	17.5	18.1	18.8	19.3	20.0	20.6
Maximum speed (mm/sec)	1000																		
	500																		
	475																		
	237																		
Speed setting	95%																		
	75%																		

Note 1. Stop positions are determined by the mechanical stoppers at both ends.
 Note 2. Minimum bend radius of motor cable is R50.
 Note 3. Weight of models with no brake. The weight of brake-attached models is 0.4 kg heavier than the models with no brake shown in the table.
 Note 4. When the stroke is longer than 750mm, resonance of the ball screw may occur depending on the operation conditions (critical speed). In this case, reduce the speed setting on the program by referring to the maximum speeds shown in the table at the left.

Controller

SR1-X ▶ 516 TS-X ▶ 490 RDV-X ▶ 504

C14H

● Origin on the non-motor side is selectable: Lead 20 • 10



Ordering method

C14H

Model	Lead	Brake	Option	Stroke	Cable length	TSX	SR1-X	RDV-X	Battery
	20: 20mm 10: 10mm 5: 5mm	No entry: With no brake BK: With brake	Origin position change None: Standard Z: Non-motor side	150 to 1050 (50mm pitch)	3L: 3.5m 5L: 5m 10L: 10m 3K/5K/10K (Flexible cable)	Positioner TS-X Driver: Power-supply voltage / Power capacity 110: 100V/200W 210: 200V/200W Regenerative unit No entry: None R: With RGT LCD monitor No entry: None L: With LCD	Controller 10 Driver: Power capacity 10: 200W Usable for CE No entry: Standard E: CE marking Regenerative unit No entry: None R: With RG1	Driver 2 Power-supply voltage 2: AC200V 10 Driver: Power capacity 10: 200W or less	I/O selection N: NPN P: PNP CC: CC-Link DN: DeviceNet™ EP: EtherNet/IP™ PT: PROFINET GW: No I/O board Battery B: With battery (Absolute) N: None (Incremental)

Note 1. If selecting 5mm lead specifications then the origin point cannot be changed to the non-motor side.
 Note 2. The robot cable is standard cable (3L/5L/10L), but can be changed to flexible cable. See P.594 for details on robot cable.
 Note 3. See P.498 for DIN rail mounting bracket.
 Note 4. Select this selection when using the gateway function. For details, see P.60.

Basic specifications

AC servo motor output (W)	200
Repeatability (mm)	+/-0.01
Deceleration mechanism	Ball screw (Class C7)
Ball screw lead (mm)	20 10 5
Maximum speed (mm/sec)	1000 500 250
Maximum payload (kg)	Horizontal 40 80 100 Vertical 8 20 30
Rated thrust (N)	170 341 683
Stroke (mm)	150 to 1050 (50mm pitch)
Overall length (mm)	Horizontal Stroke+349 Vertical Stroke+379
Maximum outside dimension of body cross-section (mm)	W136 x H96
Cable length (m)	Standard: 3.5 / Option: 5, 10
Degree of cleanliness	CLASS 10
Intake air (Nl/min)	30 to 90

Note 1. Positioning repeatability in one direction.
 Note 2. When the stroke is longer than 750mm, resonance of the ball screw may occur depending on the operation conditions (critical speed). In this case, reduce the speed setting on the program by referring to the maximum speeds shown in the table below.
 Note 3. Per 1cf (0.1um base), when suction blower is used.
 Note 4. The necessary intake amount varies depending on the use conditions and environment.

Allowable overhang

Lead	Horizontal installation (Unit: mm)			Wall installation (Unit: mm)			Vertical installation (Unit: mm)		
	A	B	C	A	B	C	A	C	
Lead 20	10kg	2247	1675	987	1210	1678	4kg	2400	2008
	20kg	1397	855	528	497	548	6kg	1687	1358
	40kg	1037	445	318	247	217	8kg	1287	1033
Lead 10	30kg	1937	583	478	402	328	10kg	1347	1088
	50kg	1637	364	323	227	152	15kg	887	718
	80kg	1717	242	235	119	74	20kg	657	538
Lead 5	60kg	2443	311	313	197	108	20kg	747	608
	80kg	2193	242	250	127	53	25kg	663	484
	100kg	2000	202	213	85	20	30kg	491	396

Note. Distance from center of slider top to center of gravity of object being carried at a guide service life of 10,000 km.

Static loading moment

(Unit: N·m)		
MY	MP	MR
293	294	258

Controller

Controller	Operation method
SR1-X10	Programming / I/O point trace / Remote command
RCX221/222	Operation using RS-232C communication
RCX240/340	I/O point trace / Remote command
TS-X110	Pulse train control
TS-X210	
RDV-X210-RBR1	

Note. Regenerative unit is required when used vertically.

C14H

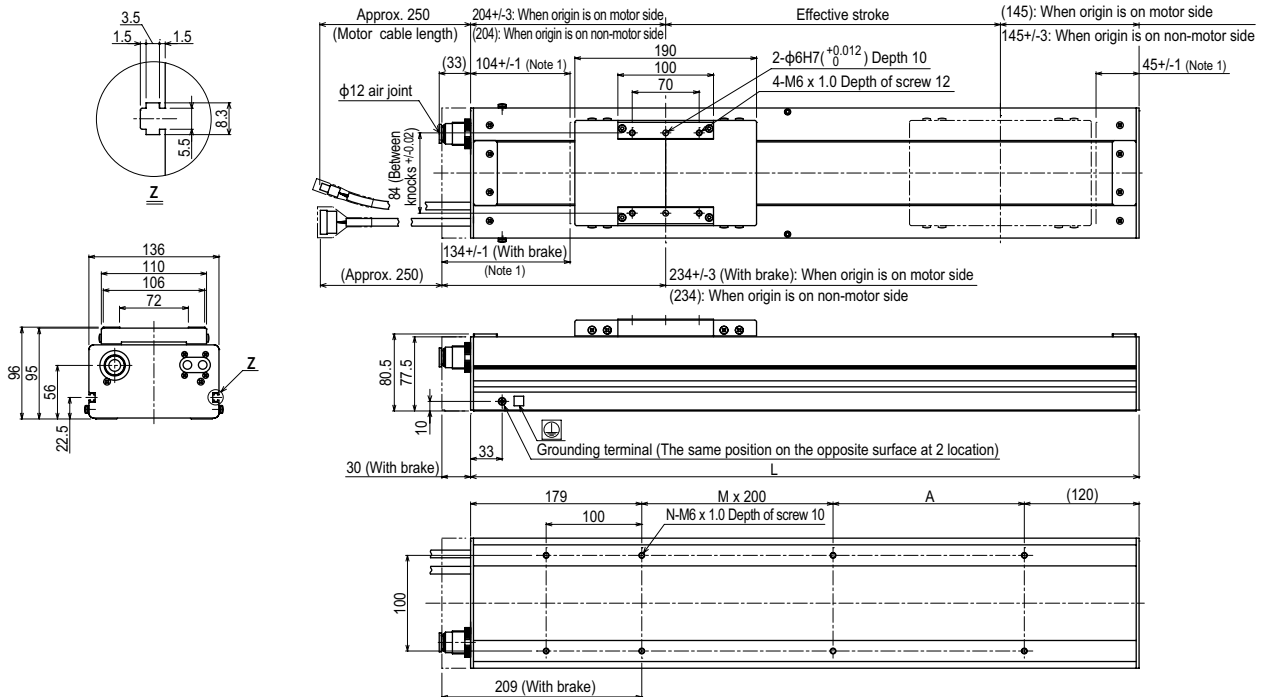

Effective stroke	150	200	250	300	350	400	450	500	550	600	650	700	750	800	850	900	950	1000	1050
	L	499	549	599	649	699	749	799	849	899	949	999	1049	1099	1149	1199	1249	1299	1349
A	200	50	100	150	200	50	100	150	200	50	100	150	200	50	100	150	200	50	100
M	0	1	1	1	1	2	2	2	2	3	3	3	3	4	4	4	4	5	5
N	6	8	8	8	8	10	10	10	10	12	12	12	12	14	14	14	14	16	16
Weight (kg) Note 3	10.7	11.4	12.0	12.7	13.2	13.9	14.5	15.2	15.8	16.5	17.0	17.7	18.3	19.0	19.6	20.3	20.8	21.5	22.1
Maximum speed (mm/sec) Note 4	Lead 20	1000																	
	Lead 10	500																	
	Lead 5	250																	
	Speed setting	95% 95% 75% 75% 60% 60% 50%																	

Note 1. Stop positions are determined by the mechanical stoppers at both ends.
 Note 2. Minimum bend radius of motor cable is R50.
 Note 3. Weight of models with no brake. The weight of brake-attached models is 0.4 kg heavier than the models with no brake shown in the table.

Note 4. When the stroke is longer than 750mm, resonance of the ball screw may occur depending on the operation conditions (critical speed). In this case, reduce the speed setting on the program by referring to the maximum speeds shown in the table at the left.

C17

Origin on the non-motor side is selectable



Ordering method

C17	Model	Lead 20: 20mm 10: 10mm	Brake No entry: With no brake BK: With brake	Option Origin position change None: Standard Z: Non-motor side	Stroke 200 to 1250 (50mm pitch)	Cable length 3L: 3.5m 5L: 5m 10L: 10m 3K/5K/10K (Flexible cable)	TSX Positioner TS-X	220 Driver: Power-supply voltage / Power capacity 220: 200V/400 to 600W	Regenerative unit No entry: None R: With RGT	LCD monitor No entry: None L: With LCD	I/O selection NP: NPN PN: PNP CC: CC-Link DN: DeviceNet™ EP: EtherNet/IP™ PT: PROFINET GW: No I/O board	Battery B: With battery (Absolute) N: None (Incremental)
	SR1-X Controller	20 Driver: Power capacity 20: 400 to 600W	Usable for CE No entry: Standard E: CE marking	Regenerative unit No entry: None R: With RG1	I/O selection N: NPN P: PNP CC: CC-Link DN: DeviceNet™ PB: PROFIBUS	Battery B: With battery (Absolute) N: None (Incremental)						
	RDV-X Driver	2 Power-supply voltage 2: AC200V	20 Driver: Power capacity 20: 400W or less	Regenerative unit RBR1 (Horizontal) RBR2 (Vertical)								

Note 1. The robot cable is standard cable (3L/5L/10L), but can be changed to flexible cable. See P.594 for details on robot cable.
 Note 2. See P.498 for DIN rail mounting bracket.
 Note 3. Select this selection when using the gateway function. For details, see P.60.

Basic specifications

AC servo motor output (W)	400
Repeatability (mm)	+/-0.01
Deceleration mechanism	Ball screw (Class C7)
Ball screw lead (mm)	20 10
Maximum speed (mm/sec)	1000 600
Maximum payload (kg)	Horizontal 80 120 Vertical 15 35
Rated thrust (N)	339 678
Stroke (mm)	200 to 1250 (50mm pitch)
Overall length (mm)	Horizontal Stroke+395 Vertical Stroke+425
Maximum outside dimension of body cross-section (mm)	W168 x H114
Cable length (m)	Standard: 3.5 / OP: 5, 10
Degree of cleanliness	CLASS 10
Intake air (Nl/min)	30 to 90

Note 1. Positioning repeatability in one direction.
 Note 2. When the stroke is longer than 950mm, resonance of the ball screw may occur depending on the operation conditions (critical speed). In this case, reduce the speed setting on the program by referring to the maximum speeds shown in the table below.
 Note 3. Per 1cf (0.1um base), when suction blower is used.
 Note 4. The necessary intake amount varies depending on the use conditions and environment.

Allowable overhang

	Horizontal installation (Unit: mm)			Wall installation (Unit: mm)			Vertical installation (Unit: mm)		
	A	B	C	A	B	C	A	C	
Lead 20									
30kg	2660	871	1040	1017	789	2576	5kg	3000 3000	
50kg	1911	508	615	583	426	1808	10kg	2443 2443	
80kg	1541	303	377	338	221	1380	15kg	1633 1633	
Lead 10							20kg	1013 1013	
60kg	2443	418	580	525	336	2443	15kg	1728 1728	
100kg	2000	237	330	271	155	2000	25kg	1013 1013	
120kg	1841	192	268	207	109	1841	35kg	707 707	

Note. Distance from center of slider top to center of gravity of object being carried at a guide service life of 10,000 km.

Static loading moment

(Unit: N·m)		
MY	MP	MR
1032	1034	908

Controller

Controller	Operation method
SR1-X20	Programming / I/O point trace / Remote command / Operation using RS-232C communication
RCX221/222	Programming / I/O point trace / Remote command / Operation using RS-232C communication
RCX240/340	Programming / I/O point trace / Remote command / Operation using RS-232C communication
TS-X220	I/O point trace / Remote command
RDV-X220-RBR1	Pulse train control (Horizontal)
RDV-X220-RBR2	Pulse train control (Vertical)

Note. Regenerative unit is required when used perpendicularly and moving at maximum speeds exceeding 1000mm/sec.

C17

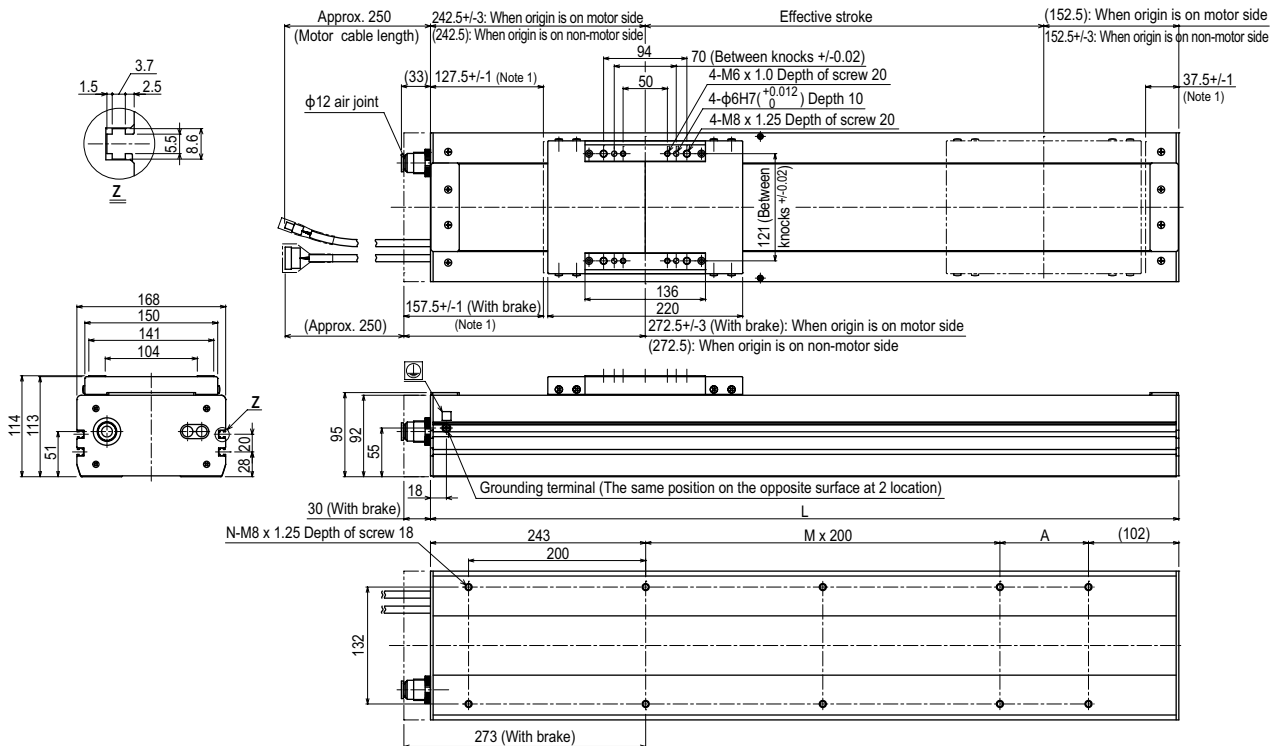

Effective stroke	L	Stroke (mm)																							
		200	250	300	350	400	450	500	550	600	650	700	750	800	850	900	950	1000	1050	1100	1150	1200	1250		
A	595	645	695	745	795	845	895	945	995	1045	1095	1145	1195	1245	1295	1345	1395	1445	1495	1545	1595	1645	1645		
M	1	1	1	1	2	2	2	2	3	3	3	3	4	4	4	4	5	5	5	5	6	6	6		
N	8	8	8	8	10	10	10	10	12	12	12	12	14	14	14	14	16	16	16	16	18	18	18		
Weight (kg)	15.0	16.0	17.0	17.9	18.9	19.8	20.8	21.7	22.7	23.6	24.6	25.5	26.5	27.4	28.4	29.3	30.3	31.2	32.2	33.1	34.1	35.0	35.0		
Maximum speed (mm/sec)	Lead 20	1000																							
	Lead 10	500																							
Speed setting	Lead 20	-																							
	Lead 10	80%	80%	70%	70%	70%	70%	70%	70%	70%	70%	70%	70%	70%	70%	70%	70%	70%	70%	70%	60%	60%	50%	50%	

Note 1. Stop positions are determined by the mechanical stoppers at both ends.
 Note 2. Minimum bend radius of motor cable is R50.
 Note 3. Weight of models with no brake. The weight of brake-attached models is 1.5 kg heavier than the models with no brake shown in the table.
 Note 4. When the stroke is longer than 950mm, resonance of the ball screw may occur depending on the operation conditions (critical speed). In this case, reduce the speed setting on the program by referring to the maximum speeds shown in the table at the left.

C17L

Origin on the non-motor side is selectable

Note. Built-to-order product. Contact us for the delivery period.

Ordering method

C17L - 50

Model	Lead	Brake	Option	Stroke	Cable length
		No entry: With no brake BK: With brake	Origin position change None: Standard Z: Non-motor side	1150 to 2050 (100mm pitch)	3L: 3.5m 5L: 5m 10L: 10m 3K/5K/10K (Flexible cable)

Positioner	220	R	LCD monitor	I/O selection	Battery
TS-X	Driver: Power-supply voltage / Power capacity 220: 200V/400 to 600W	Regenerative unit R: With RGT	No entry: None L: With LCD	N: NPN P: PNP CC: CC-Link DN: DeviceNet™ EP: EtherNet/IP™ PT: PROFINET GW: No I/O board	B: With battery (Absolute) N: None (Incremental)

Controller	20	R	I/O selection	Battery
SR1-X	Driver: Power capacity 20: 400 to 600W	Usable for CE No entry: Standard E: CE marking	N: NPN P: PNP CC: CC-Link DN: DeviceNet™ PB: PROFIBUS	B: With battery (Absolute) N: None (Incremental)

Driver	2	20	Regenerative unit
RDV-X	Power-supply voltage 2: AC200V	Driver: Power capacity 20: 400W or less	RBR1 (Horizontal) RBR2 (Vertical)

Note 1. The robot cable is standard cable (3L/5L/10L), but can be changed to flexible cable. See P.594 for details on robot cable.
 Note 2. See P.498 for DIN rail mounting bracket.
 Note 3. Acceleration / deceleration is different depending the Positioner or Controller or Driver.
 Note 4. Select this selection when using the gateway function. For details, see P.60.

Basic specifications

AC servo motor output (W)	600
Repeatability (mm)	+/-0.02
Deceleration mechanism	Ball screw (Class C10)
Ball screw lead (mm)	50
Maximum speed (mm/sec)	1000
Maximum payload (kg)	Horizontal: 50 Vertical: 10
Rated thrust (N)	204
Stroke (mm)	1150 to 2050 (100 pitch)
Overall length (mm)	Horizontal: Stroke+485 Vertical: Stroke+515
Maximum outside dimension of body cross-section (mm)	W168 x H114
Cable length (m)	Standard: 3.5 / Option: 5, 10
Degree of cleanliness	CLASS 10
Intake air (Nl/min)	30 to 90

Note 1. Positioning repeatability in one direction.
 Note 2. When the stroke is longer than 1850mm, resonance of the ball screw may occur depending on the operation conditions (critical speed). In this case, reduce the speed setting on the program by referring to the maximum speeds shown in the table below.
 Note 3. Per 1cf (0.1um base), when suction blower is used.
 Note 4. The necessary intake amount varies depending on the use conditions and environment.

Allowable overhang

Lead 50	Horizontal installation (Unit: mm)			Wall installation (Unit: mm)			Vertical installation (Unit: mm)			
	A	B	C	A	B	C	A	C		
10kg	4000	2687	3327	10kg	3436	2605	4000	2kg	1200	1200
30kg	3045	872	929	30kg	1169	790	3045	5kg	3000	3000
50kg	2602	509	714	50kg	666	427	2602	10kg	2579	2579

Note. Distance from center of slider top to center of gravity of object being carried at a guide service life of 10,000 km.

Static loading moment

(Unit: N·m)		
MY	MP	MR
1032	1034	908

Controller

Controller	Operation method
SR1-X20-R RCX221/222 RCX240/340	Programming / I/O point trace / Remote command / Operation using RS-232C communication
TS-X220-R	I/O point trace / Remote command
RDV-X220-RBR1 (Horizontal) RDV-X220-RBR2 (Vertical)	Pulse train control

C17L

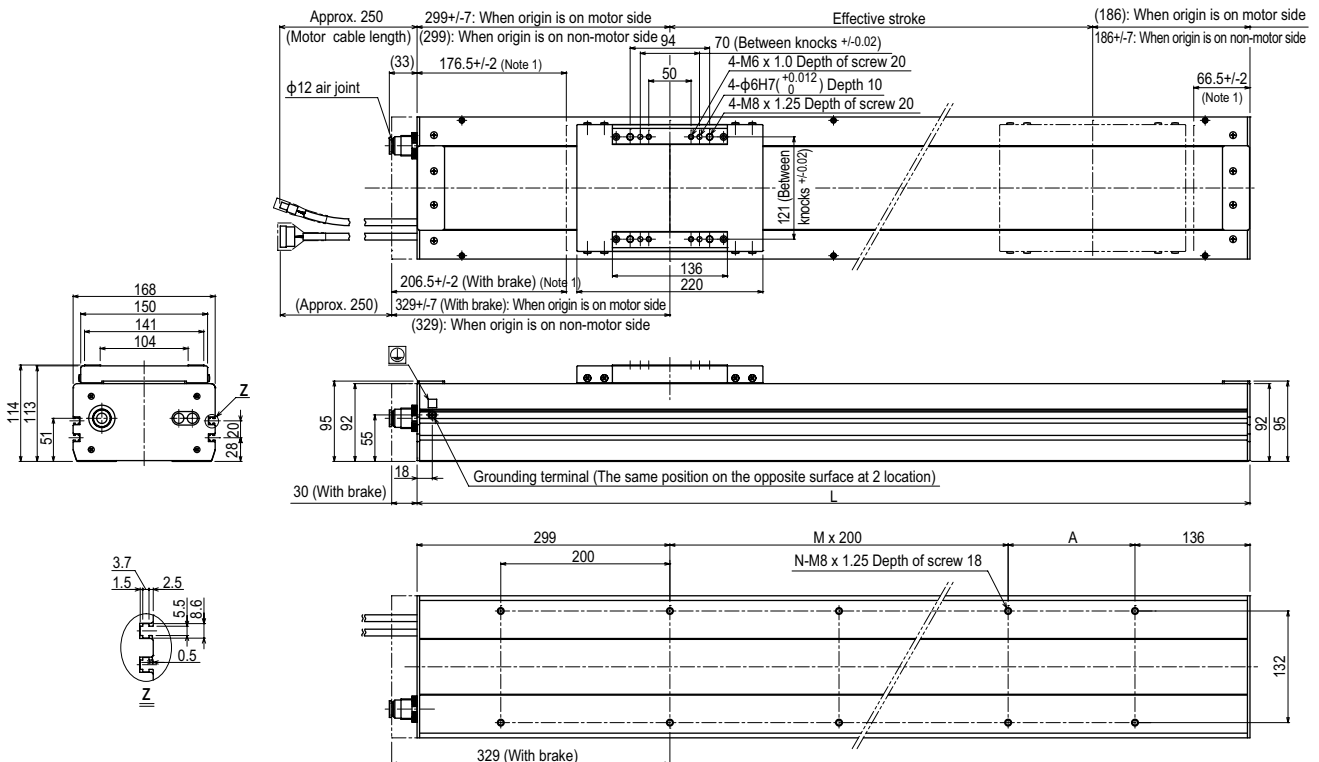

Effective stroke	1150	1250	1350	1450	1550	1650	1750	1850	1950	2050
L	1635	1735	1835	1935	2035	2135	2235	2335	2435	2535
A	200	100	200	100	200	100	200	100	200	100
M	5	6	6	7	7	8	8	9	9	10
N	16	18	18	20	20	22	22	24	24	26
Weight (kg) Note 3	39.1	41.2	43.2	45.2	47.3	49.3	51.3	53.4	55.4	57.4
Maximum speed (mm/sec) Note 4	Lead 50					Speed setting				
	1000					-				
						90%				
						80%				

Note 1. Stop positions are determined by the mechanical stoppers at both ends.
 Note 2. Minimum bend radius of motor cable is R50.
 Note 3. Weight of models with no brake. The weight of brake-attached models is 1.5 kg heavier than the models with no brake shown in the table.
 Note 4. When the stroke is longer than 1850mm, resonance of the ball screw may occur depending on the operation conditions (critical speed). In this case, reduce the speed setting on the program by referring to the maximum speeds shown in the table at the left.

C20

● Origin on the non-motor side is selectable



Ordering method

C20	Model	Lead 20: 20mm 10: 10mm	Brake No entry: With no brake BK: With brake	Option Origin position change None: Standard Z: Non-motor side	Stroke 200 to 1250 (50mm pitch)	Cable length 3L: 3.5m 5L: 5m 10L: 10m 3K/5K/10K (Flexible cable)	TSX	220	I/O selection	Battery		
							Positioner TS-X	Driver: Power supply voltage / Power capacity 220: 200V/400 to 600W	Regenerative unit No entry: None R: With RGT	LCD monitor No entry: None L: With LCD	I/O selection NP: NPN PN: PNP CC: CC-Link EP: EtherNet/IP™ DN: DeviceNet™ PT: PROFINET GW: No I/O board	Battery B: With battery (Absolute) N: None (Incremental)
							SR1-X	20	Usable for CE No entry: Standard E: CE marking	Regenerative unit No entry: None R: With RG1	I/O selection N: NPN P: PNP CC: CC-Link DN: DeviceNet™ PB: PROFIBUS	Battery B: With battery (Absolute) N: None (Incremental)
							RDV-X	2	Power supply voltage 2: AC200V	20	Regenerative unit RBR1 (Horizontal) RBR2 (Vertical)	

Note 1. Only the model with specifications with brake (vertical specifications) can select a lead of 10mm.
 Note 2. The robot cable is standard cable (3L/5L/10L), but can be changed to flexible cable. See P.594 for details on robot cable.
 Note 3. See P.498 for DIN rail mounting bracket.
 Note 4. Acceleration / deceleration is different depending the Positioner or Controller or Driver.
 Note 5. Select this selection when using the gateway function. For details, see P.60.

Basic specifications

AC servo motor output (W)	600
Repeatability (mm)	+/-0.01
Deceleration mechanism	Ball screw (Class C7)
Ball screw lead (mm)	20 10
Maximum speed (mm/sec)	1000 500
Maximum payload (kg)	Horizontal 120 Vertical 25 45
Rated thrust (N)	510 1020
Stroke (mm)	200 to 1250 (50mm pitch)
Overall length (mm)	Horizontal Stroke+441 Vertical Stroke+471
Maximum outside dimension of body cross-section (mm)	W202 x H117
Cable length (m)	Standard: 3.5 / Option: 5, 10
Degree of cleanliness	CLASS 10
Intake air (Nl/min)	30 to 90

Note 1. Positioning repeatability in one direction.
 Note 2. When the stroke is longer than 950mm, resonance of the ball screw may occur depending on the operation conditions (critical speed). In this case, reduce the speed setting on the program by referring to the maximum speeds shown in the table below.
 Note 3. Per 1cf (0.1um base), when suction blower is used.
 Note 4. The necessary intake amount varies depending on the use conditions and environment.

Allowable overhang

Horizontal installation (Unit: mm)	Lead 20	50kg	2602	869	1145
		80kg	2193	528	720
Wall installation (Unit: mm)	Lead 20	50kg	1144	798	2602
		80kg	717	456	2193
Vertical installation (Unit: mm)	Lead 10	15kg	2711	2711	
		20kg	2045	2045	
	Lead 20	20kg	2182	2182	
		30kg	1437	1437	
	Lead 10	20kg	939	939	
		45kg	939	939	

Note. Distance from center of slider top to center of gravity of object being carried at a guide service life of 10,000 km.

Static loading moment

	(Unit: N·m)		
	MY	MP	MR
	1101	1103	968

Controller

Controller	Operation method
SR1-X20 RCX221/222 RCX240/340	Programming / I/O point trace / Remote command / Operation using RS-232C communication
TS-X220	I/O point trace / Remote command
RDV-X220-RBR1 RDV-X220-RBR2	Pulse train control (Horizontal) Pulse train control (Vertical)

Note. Regenerative unit is required when used vertically and moving at maximum speeds exceeding 1000mm/sec.

C20

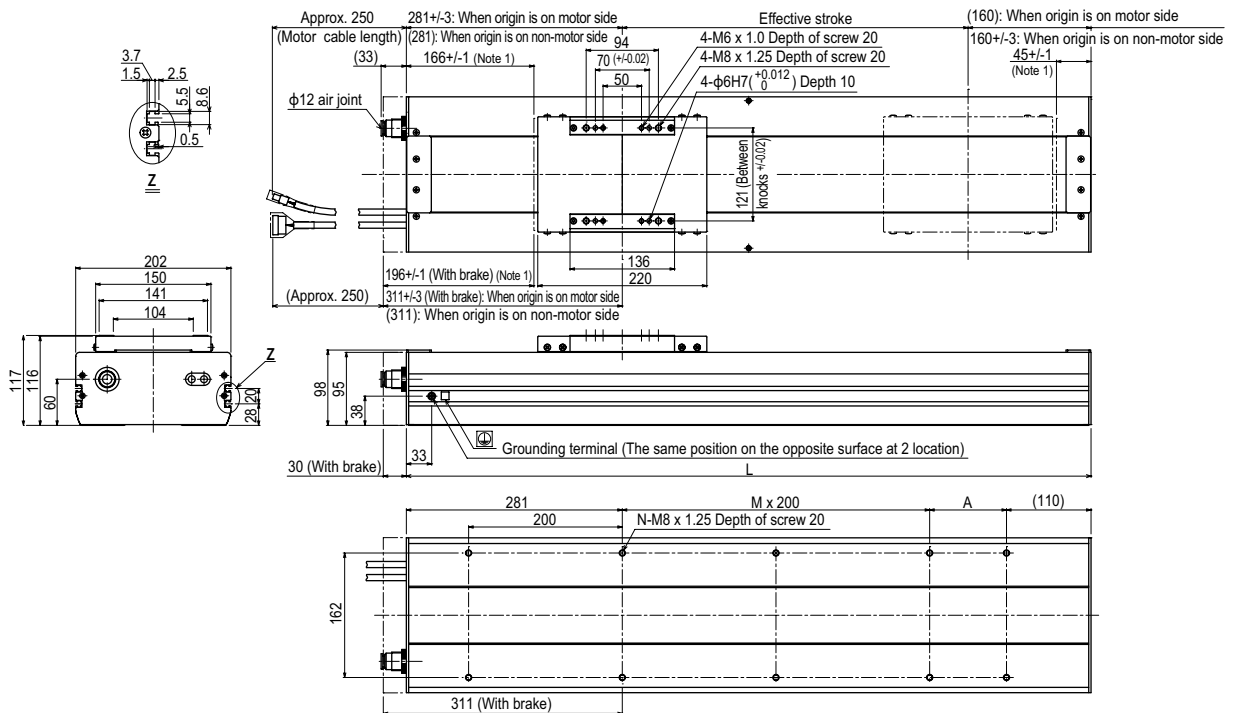

Effective stroke	200	250	300	350	400	450	500	550	600	650	700	750	800	850	900	950	1000	1050	1100	1150	1200	1250			
L	641	691	741	791	841	891	941	991	1041	1091	1141	1191	1241	1291	1341	1391	1441	1491	1541	1591	1641	1691			
A	50	100	150	200	50	100	150	200	50	100	150	200	50	100	150	200	50	100	150	200	50	100			
M	1	1	1	1	2	2	2	2	3	3	3	3	4	4	4	4	5	5	5	5	6	6			
N	8	8	8	8	10	10	10	10	12	12	12	12	14	14	14	14	16	16	16	16	18	18			
Weight (kg)	25.0	26.0	27.0	28.0	29.0	30.0	31.0	32.0	33.0	34.0	35.0	36.0	37.0	38.0	39.0	40.0	41.0	42.0	43.0	44.0	45.0	46.0			
Maximum speed (mm/sec)	Lead 20												1000												
	Lead 10												500												
Speed setting	Lead 20												80%	80%	70%	70%	60%	60%	50%						
	Lead 10												80%	80%	70%	70%	60%	60%	50%						

Note 1. Stop positions are determined by the mechanical stoppers at both ends.
 Note 2. Minimum bend radius of motor cable is R50.
 Note 3. Weight of models with no brake. The weight of brake-attached models is 2.0 kg heavier than the models with no brake shown in the table.
 Note 4. When the stroke is longer than 950mm, resonance of the ball screw may occur depending on the operation conditions (critical speed). In this case, reduce the speed setting on the program by referring to the maximum speeds shown in the table at the left.

Controller

SR1-X ▶ 516 TS-X ▶ 490 RDV-X ▶ 504

SXYxC 2 axes

● Clean type ● Cable duct



Ordering method

SXYxC	D					RCX222			
Model	Cable	Combination	X axis stroke	Y axis stroke	Cable length	Controller	Usable for CE	Input/Output selection 1	Input/Output selection 2
	D: Cable duct	T1 T2 T3	15 to 105cm	15 to 65cm	3L: 3.5m 5L: 5m 10L: 10m	RCX222	No entry: Standard E: CE marking	N: NPN P: PNP CC: CC-Link DN: DeviceNet™ PB: PROFIBUS EN: Ethernet YC: YC-Link	No entry: None N: OP.DIO24/16 (NPN) P: OP.DIO24/17 (PNP) EN: Ethernet

Note 1. NPN cannot be selected if using CE marking.
 Note 2. Available only for the master. See P.66 for details on YC-Link system.
 Note 3. Only when CC or DN or PB was selected for I/O select 1 above, EN can be selected in I/O select 2.

Basic specifications

	X axis	Y axis
Axis construction <small>Note 1</small>	C14H	C14
AC servo motor output (W)	200	100
Repeatability <small>Note 2</small> (mm)	+/-0.01	+/-0.01
Drive system	Ball screw (Class C7)	Ball screw (Class C7)
Ball screw lead <small>Note 3</small> (Deceleration ratio) (mm)	20	20
Maximum speed <small>Note 4</small> (mm/sec)	1000	1000
Moving range (mm)	150 to 1050	150 to 650
Robot cable length (m)	Standard: 3.5 Option: 5, 10	
Degree of cleanliness	CLASS 10 <small>Note 5</small>	
Intake air (Nℓ/min)	60 <small>Note 6</small>	

Note 1. Use caution that the frame machining (installation holes, tap holes) differs from single-axis robots.
 Note 2. Positioning repeatability in one direction.
 Note 3. Leads not listed in the catalog are also available. Contact us for details.
 Note 4. When the X-axis stroke is longer than 850mm, resonance of the ball screw may occur depending on the operation conditions (critical speed). In this case, reduce the speed setting on the program by referring to the maximum speeds shown in the table below.
 Note 5. Per 1cf (0.1µm base), when suction blower is used.
 Note 6. The necessary intake amount varies depending on the use conditions and environment.

Maximum payload (kg)

Y stroke (mm)	XY 2 axes
150	20
250	17
350	15
450	13
550	11
650	9

Controller

Controller	Operation method
RCX222	Programming / I/O point trace / Remote command / Operation using RS-232C communication

SXYxC 2 axes T1

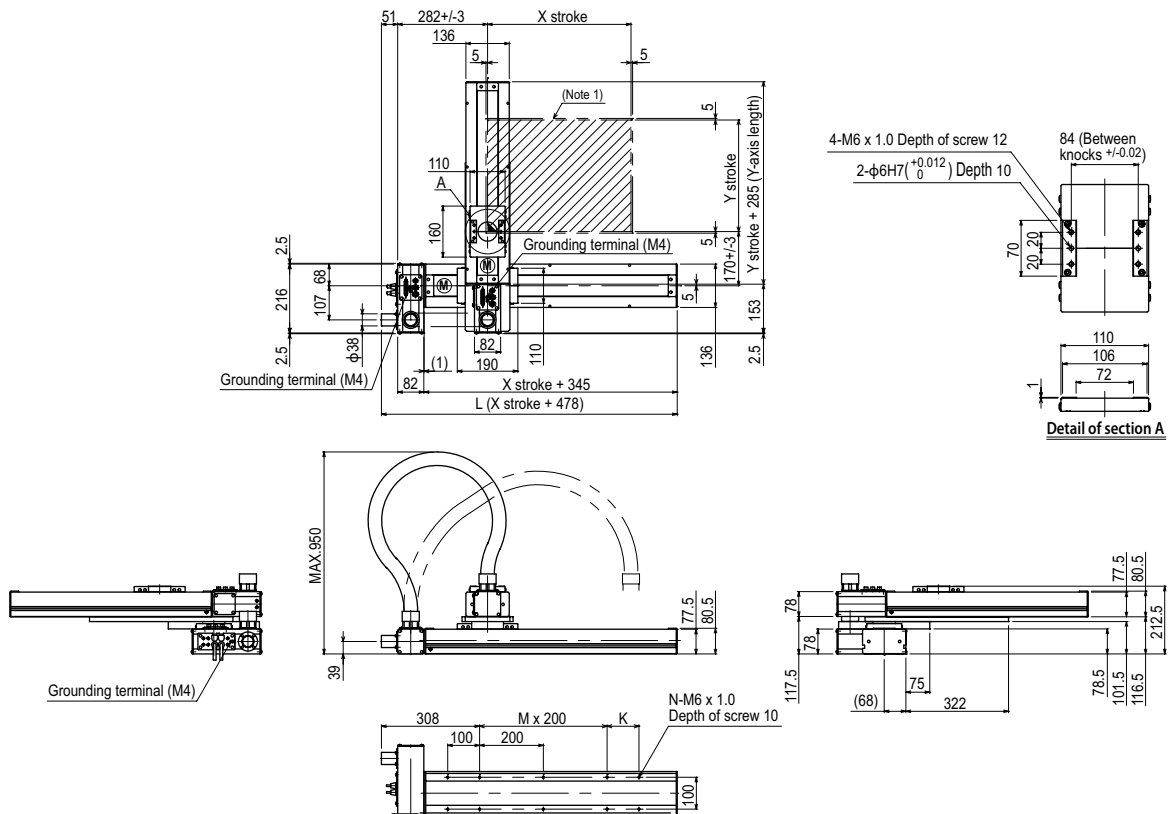

X stroke	150	250	350	450	550	650	750	850	950	1050	
	L	628	728	828	928	1028	1128	1228	1328	1428	1528
K	200	100	200	100	200	100	200	100	200	100	
M	0	1	1	2	2	3	3	4	4	5	
N	6	8	8	10	10	12	12	14	14	16	
Y stroke	150	250	350	450	550	650					
Maximum speed for each stroke (mm/sec) <small>Note 2</small>	1000					800	650	550			
Speed setting	-					80%	65%	55%			

Note 1. The moving range when returning to origin and the stop position when stopping by mechanical stopper.

Note 2. When the X-axis stroke is longer than 850mm, resonance of the ball screw may occur depending on the operation conditions (critical speed). In this case, reduce the speed setting on the program by referring to the maximum speeds shown in the table at the left.

SXYxC 2 axes T3

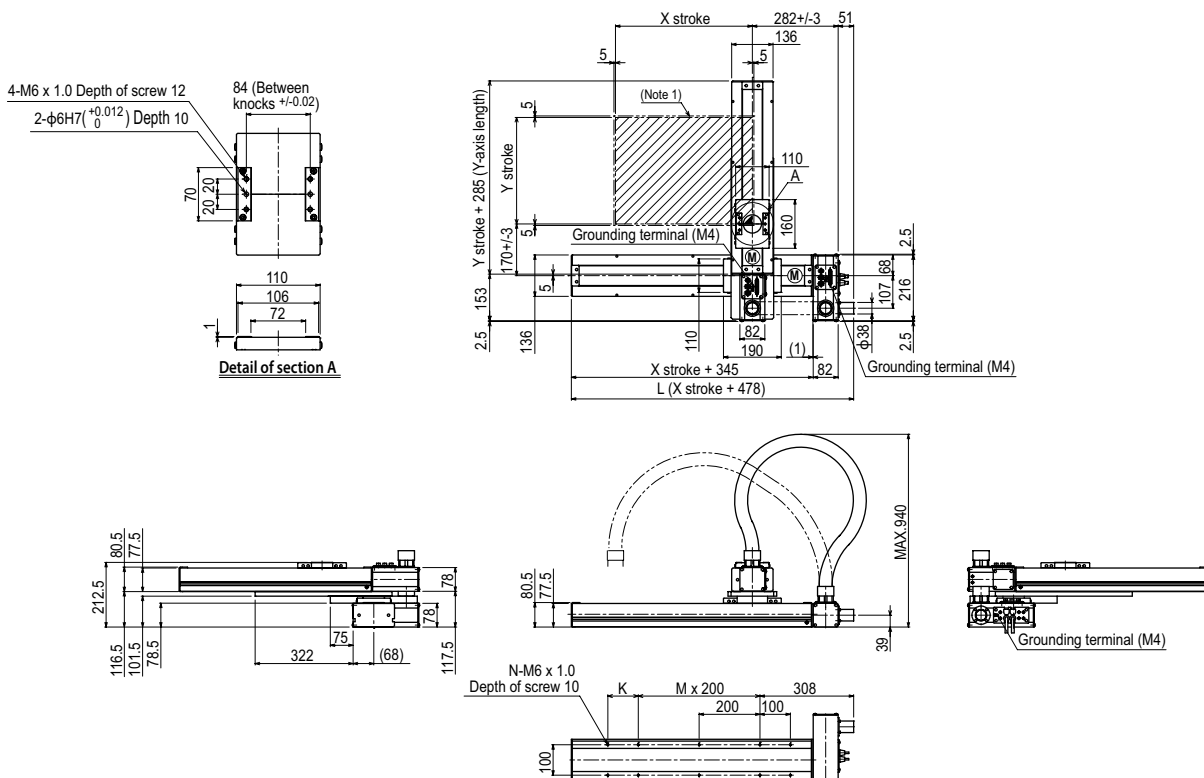

X stroke	150	250	350	450	550	650	750	850	950	1050	
L	628	728	828	928	1028	1128	1228	1328	1428	1528	
K	200	100	200	100	200	100	200	100	200	100	
M	0	1	1	2	2	3	3	4	4	5	
N	6	8	8	10	10	12	12	14	14	16	
Y stroke	150	250	350	450	550	650					
Maximum speed for each stroke (mm/sec) ^{Note 2}	1000						800	650	550		
Speed setting	-						80%	65%	55%		

Note 1. The moving range when returning to origin and the stop position when stopping by mechanical stopper.

Note 2. When the X-axis stroke is longer than 850mm, resonance of the ball screw may occur depending on the operation conditions (critical speed). In this case, reduce the speed setting on the program by referring to the maximum speeds shown in the table at the left.

SXYxC 3 axes / ZSC T3

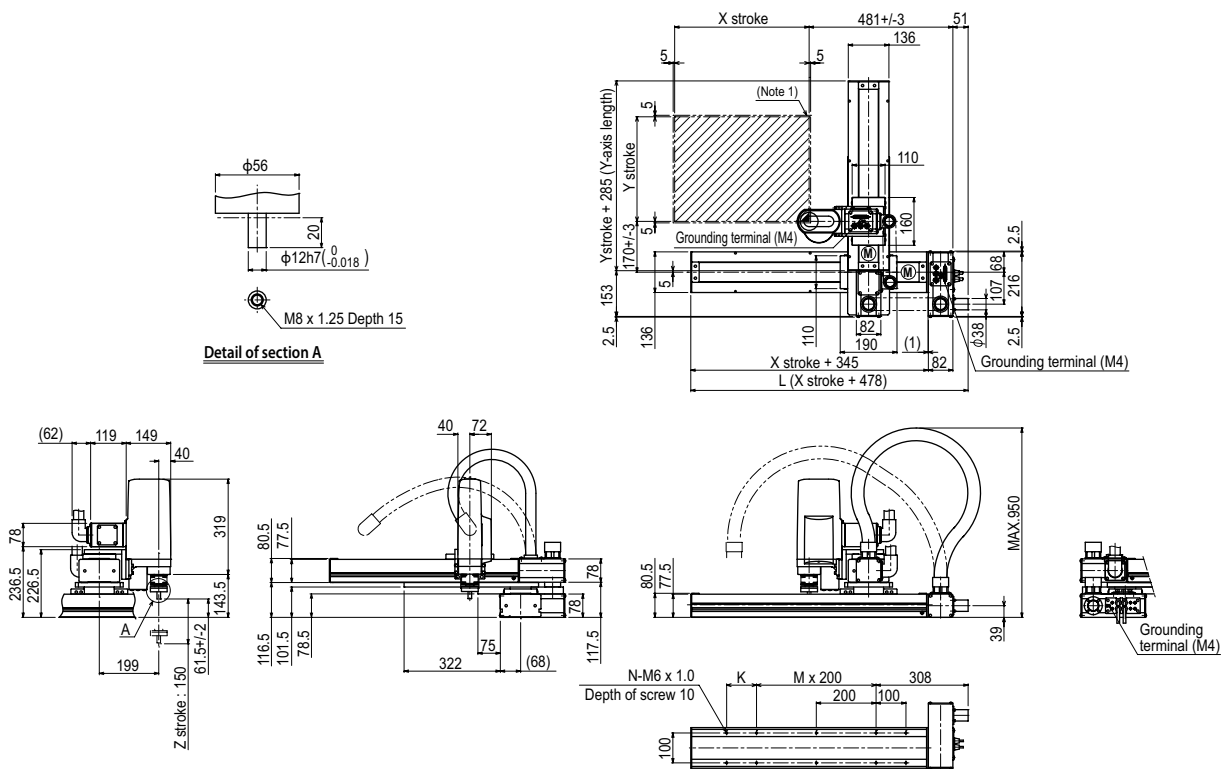

X stroke	150	250	350	450	550	650	750	850	950	1050	
L	628	728	828	928	1028	1128	1228	1328	1428	1528	
K	200	100	200	100	200	100	200	100	200	100	
M	0	1	1	2	2	3	3	4	4	5	
N	6	8	8	10	10	12	12	14	14	16	
Y stroke	150	250	350	450	550	650					
Z stroke	150										
Maximum speed for each stroke (mm/sec) Note 2	X axis	1000					800	650	550		
	Speed setting	-					80%	65%	55%		

Note 1. The moving range when returning to origin and the stop position when stopping by mechanical stopper.

Note 2. When the X-axis stroke is longer than 850mm, resonance of the ball screw may occur depending on the operation conditions (critical speed). In this case, reduce the speed setting on the program by referring to the maximum speeds shown in the table at the left.

SXYxC

4 axes / ZRSC

- Clean type
- Cable duct
- ZR-axis integrated type



Ordering method

SXYxC	D					15	
Model	Cable	Combination	X axis stroke	Y axis stroke	ZR axis	Z axis stroke	Cable length
	D: Cable duct	T1 T3	15 to 105cm	15 to 65cm	ZRSC12 ZRSC6		3L: 3.5m 5L: 5m 10L: 10m

RCX340-4									
Controller / Number of controllable axes	Safety standard	Option A (OP.A)	Option B (OP.B)	Option C (OP.C)	Option D (OP.D)	Option E (OP.E)	Absolute battery		

Specify various controller setting items. RCX340 ▶ **P.542**

RCX240S									
Controller	CE Marking	Expansion I/O	Network option	IVY System	Gripper	Battery			

Specify various controller setting items. RCX240/RCX240S ▶ **P.532**

Basic specifications

	X axis	Y axis	Z axis ZRSC12	Z axis ZRSC6	R axis
Axis construction <small>Note 1</small>	C14H	C14	-	-	R5
AC servo motor output (W)	200	100	60	60	100
Repeatability <small>Note 2</small> (XYZ: mm) (R: °)	+/-0.01	+/-0.01	+/-0.02	+/-0.02	+/-0.005
Drive system	Ball screw (Class C7)	Ball screw (Class C7)	Ball screw (Class C10)	Ball screw (Class C10)	Harmonic gear
Ball screw lead <small>Note 3</small> (Deceleration ratio) (mm)	20	20	12	6	(1/50)
Maximum speed <small>Note 4</small> (XYZ: mm/sec) (R: °/sec)	1000	1000	1000	500	1020
Moving range (XYZ: mm) (R: °)	150 to 1050	150 to 650	150	150	360
Robot cable length (m)	Standard: 3.5 Option: 5, 10				
Degree of cleanliness	CLASS 10 <small>Note 5</small>				
Intake air (Nℓ/min)	90 <small>Note 6</small>				

Note 1. Use caution that the frame machining (installation holes, tap holes) differs from single-axis robots.
 Note 2. Positioning repeatability in one direction.
 Note 3. Leads not listed in the catalog are also available. Contact us for details.
 Note 4. When the X-axis stroke is longer than 850mm, resonance of the ball screw may occur depending on the operation conditions (critical speed). In this case, reduce the speed setting on the program by referring to the maximum speeds shown in the table below.
 Note 5. Per 1cf (0.1µm base), when suction blower is used.
 Note 6. The necessary intake amount varies depending on the use conditions and environment.

Maximum payload (kg)

Y stroke (mm)	ZRSC12	ZRSC6
150	3	5
250		
350		
450		
550	4	4
650		

Controller

Controller	Operation method
RCX340 RCX240S	Programming / I/O point trace / Remote command / Operation using RS-232C communication

SXYxC 4 axes / ZRSC (T1)

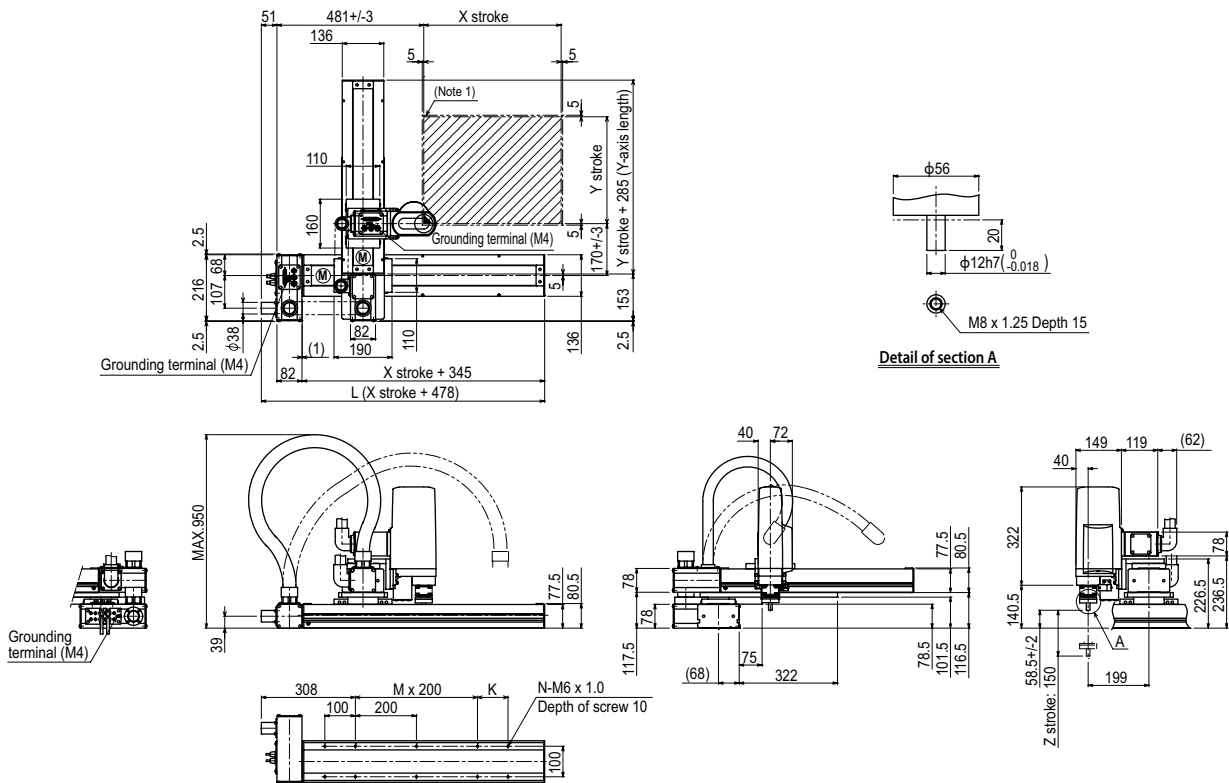

X stroke	L											
	150	250	350	450	550	650	750	850	950	1050		
L	628	728	828	928	1028	1128	1228	1328	1428	1528		
K	200	100	200	100	200	100	200	100	200	100		
M	0	1	1	2	2	3	3	4	4	5		
N	6	8	8	10	10	12	12	14	14	16		
Y stroke		150	250	350	450	550	650					
Z stroke		150										
Maximum speed for each stroke (mm/sec) <small>Note 2</small>	X axis	1000					800	650	550			
	Speed setting	-					80%	65%	55%			

Note 1. The moving range when returning to origin and the stop position when stopping by mechanical stopper.
 Note 2. When the X-axis stroke is longer than 850mm, resonance of the ball screw may occur depending on the operation conditions (critical speed). In this case, reduce the speed setting on the program by referring to the maximum speeds shown in the table at the left.

SXYxC 4 axes / ZRSC T3

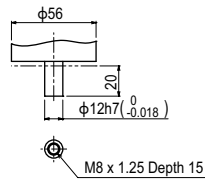

Detail of section A

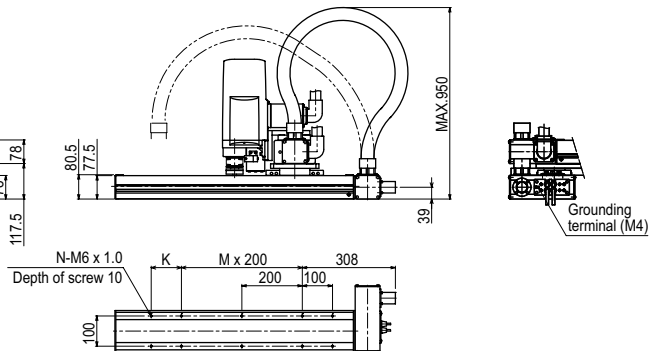
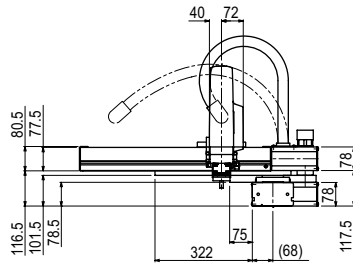
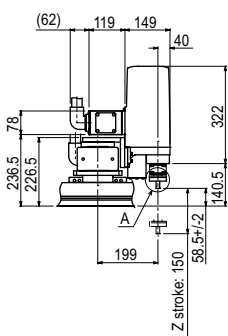
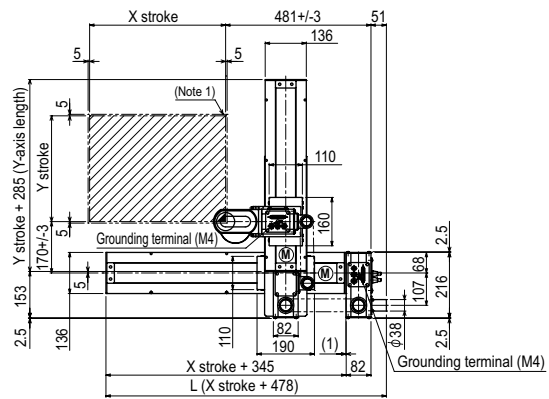

X stroke	150	250	350	450	550	650	750	850	950	1050
L	628	728	828	928	1028	1128	1228	1328	1428	1528
K	200	100	200	100	200	100	200	100	200	100
M	0	1	1	2	2	3	3	4	4	5
N	6	8	8	10	10	12	12	14	14	16
Y stroke	150	250	350	450	550	650				
Z stroke	150									
Maximum speed for each stroke (mm/sec)	X axis			1000			800	650	550	
Speed setting	-			-			80%	65%	55%	

Note 1. The moving range when returning to origin and the stop position when stopping by mechanical stopper.

Note 2. When the X-axis stroke is longer than 850mm, resonance of the ball screw may occur depending on the operation conditions (critical speed). In this case, reduce the speed setting on the program by referring to the maximum speeds shown in the table at the left.

YK250XGC

● Arm length 250mm ● Maximum payload 4kg



Ordering method

YK250XGC - 150 **S** **RCX340-4**

Model	Z axis stroke	Tool flange	Hollow shaft	Cable length	Controller / Number of controllable axes	Safety standard	Option A (OP.A)	Option B (OP.B)	Option C (OP.C)	Option D (OP.D)	Option E (OP.E)	Absolute battery
	150: 150mm	No entry: None F: With tool flange	S: With hollow shaft	3L: 3.5m 5L: 5m 10L: 10m								

Specify various controller setting items. RCX340 ▶ **P.542**

RCX240S

Controller	CE Marking	Expansion I/O	Network option	IVY System	Gripper	Battery

Specify various controller setting items. RCX240/RCX240S ▶ **P.532**

Basic specifications

	X axis	Y axis	Z axis	R axis
Axis specifications				
Arm length (mm)	100	150	150	-
Rotation angle (°)	+/-129	+/-134	-	+/-360
AC servo motor output (W)	200	150	50	100
Repeatability ^{Note 1} (XYZ: mm) (R: °)	+/-0.01		+/-0.01	+/-0.004
Maximum speed (XYZ: m/sec) (R: °/sec)	4.5		1.1	1020
Maximum payload (kg)	4			
Standard cycle time: with 2kg payload (sec) ^{Note 2}	0.57			
R-axis tolerable moment of inertia ^{Note 3} (kgm ²)	0.05			
User wiring (sq x wires)	0.2x10			
User tubing (Outer diameter)	φ4x4			
Travel limit	1.Soft limit, 2.Mechanical stopper (X, Y, Z axes)			
Robot cable length (m)	Standard: 3.5 Option: 5, 10			
Weight (kg)	21.5			
Degree of cleanliness	ISO CLASS 3 (ISO 14644-1) ^{Note 4+ESD} ^{Note 5}			
Intake air (Nl/min)	30 ^{Note 6}			

Controller

Controller	Power capacity (VA)	Operation method
RCX340 RCX240S	1000	Programming / I/O point trace / Remote command / Operation using RS-232C communication

Note. "Harmonic" and "Harmonic drive" are the registered trademarks of Harmonic Drive Systems Inc.
 Note. The movement range can be limited by changing the positions of X and Y axis mechanical stoppers. (The movement range is set to the maximum at the time of shipment.)
 See our robot manuals (installation manuals) for detailed information.
 Note. To set the standard coordinates with high accuracy, use a standard coordinate setting jig (option). Refer to the user's manual (installation manual) for more details.

Our robot manuals (installation manuals) can be downloaded from our website at the address below:
<http://global.yamaha-motor.com/business/robot/>

Note 1. This is the value at a constant ambient temperature. (X,Y axes)
 Note 2. When reciprocating 25mm in vertical direction and 300mm in horizontal direction (rough-positioning arch motion).
 Note 3. There are limits to acceleration coefficient settings. See P.607.
 Note 4. Class 10 (0.1µm) equivalent to FED-STD-209D
 Note 5. ESD (ElectroStatic Discharge) prevention is an option. Please contact our distributor.
 Note 6. The necessary intake amount varies depending on the use conditions and environment.

YK250XGC

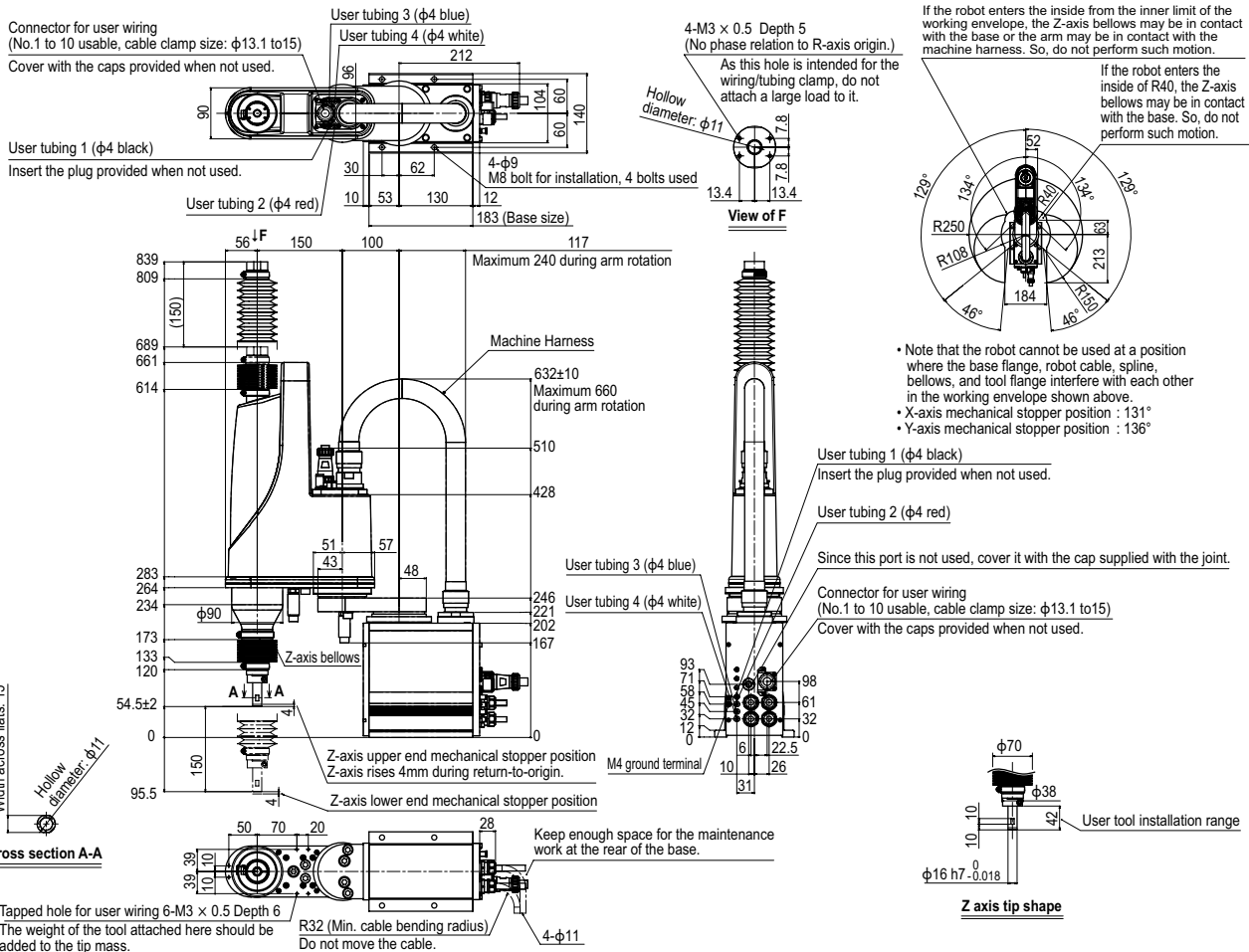

YK250XGC Tool flange mount type

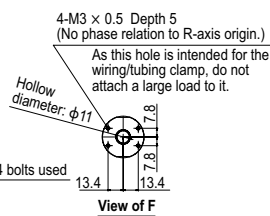
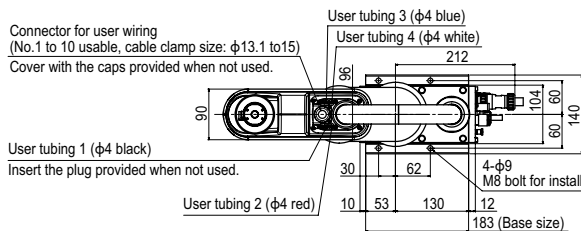

If the robot enters the inside from the inner limit of the working envelope, the Z-axis bellows may be in contact with the base or the arm may be in contact with the machine harness. So, do not perform such motion.

If the robot enters the inside of R40, the Z-axis bellows may be in contact with the base. So, do not perform such motion.

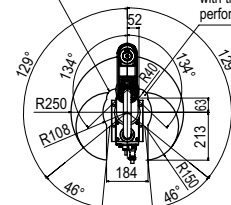

- Note that the robot cannot be used at a position where the base flange, robot cable, spline, bellows, and tool flange interfere with each other in the working envelope shown above.
- X-axis mechanical stopper position : 131°
- Y-axis mechanical stopper position : 136°

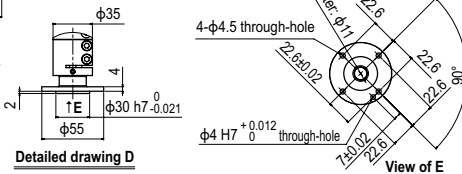
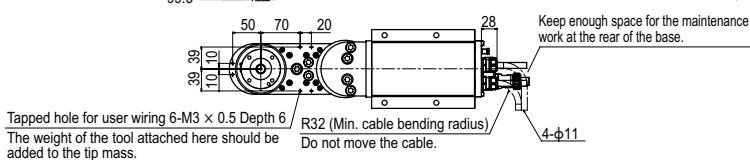
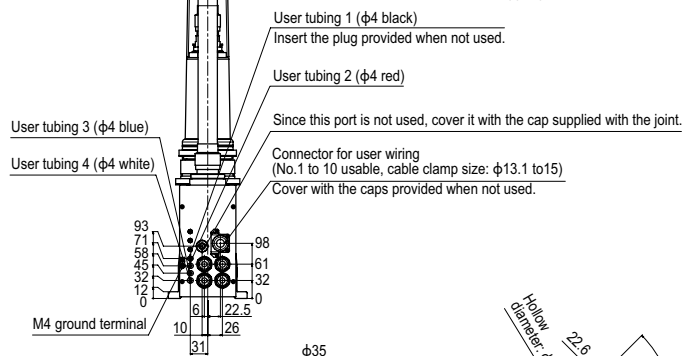
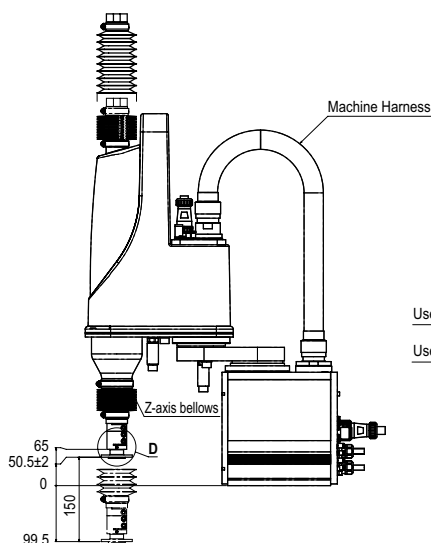

YK350XGC

- Arm length 350mm
- Maximum payload 4kg

Ordering method

YK350XGC - 150

Model	Z axis stroke 150: 150mm	Tool flange No entry: None F: With tool flange	Hollow shaft S: With hollow shaft	Cable length 3L: 3.5m 5L: 5m 10L: 10m
--------------	------------------------------------	---	---	---

S

RCX340-4

Controller / Number of controllable axes	Safety standard	Option A (OP.A)	Option B (OP.B)	Option C (OP.C)	Option D (OP.D)	Option E (OP.E)	Absolute battery
---	------------------------	------------------------	------------------------	------------------------	------------------------	------------------------	-------------------------

Specify various controller setting items. RCX340 ▶ **P542**

RCX240S

Controller	CE Marking	Expansion I/O	Network option	iVY System	Gripper	Battery
-------------------	-------------------	----------------------	-----------------------	-------------------	----------------	----------------

Specify various controller setting items. RCX240/RCX240S ▶ **P532**

Basic specifications

	X axis	Y axis	Z axis	R axis
Axis specifications				
Arm length (mm)	200	150	150	-
Rotation angle (°)	+/-129	+/-134	-	+/-360
AC servo motor output (W)	200	150	50	100
Repeatability ^{Note 1} (XYZ: mm) (R: °)	+/-0.01		+/-0.01	+/-0.004
Maximum speed (XYZ: m/sec) (R: °/sec)	5.6		1.1	1020
Maximum payload (kg)	4			
Standard cycle time: with 2kg payload (sec) ^{Note 2}	0.57			
R-axis tolerable moment of inertia ^{Note 3} (kgm ²)	0.05			
User wiring (sq x wires)	0.2x10			
User tubing (Outer diameter)	φ4x4			
Travel limit	1.Soft limit, 2.Mechanical stopper (X, Y, Z axes)			
Robot cable length (m)	Standard: 3.5 Option: 5, 10			
Weight (kg)	22			
Degree of cleanliness	ISO CLASS 3 (ISO 14644-1) ^{Note 4+ESD} ^{Note 5}			
Intake air (Nl/min)	30 ^{Note 6}			

- Note 1. This is the value at a constant ambient temperature. (X,Y axes)
 Note 2. When reciprocating 25mm in vertical direction and 300mm in horizontal direction (rough-positioning arch motion).
 Note 3. There are limits to acceleration coefficient settings. See P.607.
 Note 4. Class 10 (0.1µm) equivalent to FED-STD-209D
 Note 5. ESD (ElectroStatic Discharge) prevention is an option. Please contact our distributor.
 Note 6. The necessary intake amount varies depending on the use conditions and environment.

Controller

Controller	Power capacity (VA)	Operation method
RCX340 RCX240S	1000	Programming / I/O point trace / Remote command / Operation using RS-232C communication

- Note. "Harmonic" and "Harmonic drive" are the registered trademarks of Harmonic Drive Systems Inc.
 Note. The movement range can be limited by changing the positions of X and Y axis mechanical stoppers. (The movement range is set to the maximum at the time of shipment.)
 See our robot manuals (installation manuals) for detailed information.
 Note. To set the standard coordinates with high accuracy, use a standard coordinate setting jig (option). Refer to the user's manual (installation manual) for more details.

Our robot manuals (installation manuals) can be downloaded from our website at the address below:
<http://global.yamaha-motor.com/business/robot/>

YK350XGC

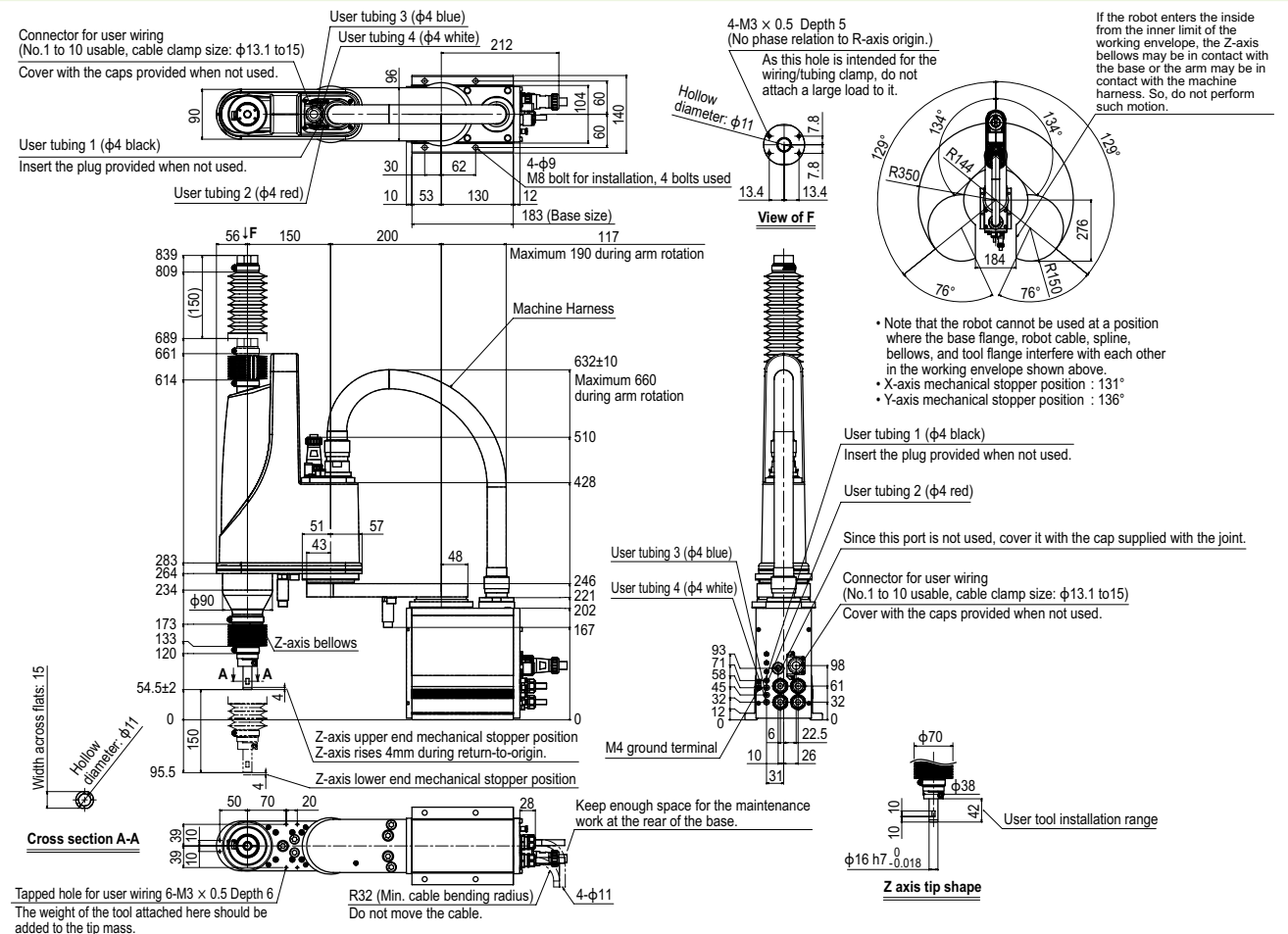

YK400XGC

● Arm length 400mm ● Maximum payload 4kg



Ordering method

YK400XGC - 150 **S** **RCX340-4**

Model: Z axis stroke 150: 150mm; Tool flange: No entry: None, F: With tool flange; Hollow shaft: S: With hollow shaft; Cable length: 3L: 3.5m, 5L: 5m, 10L: 10m

Controller / Number of controllable axes: RCX340-4; Safety standard; Option A (OP.A); Option B (OP.B); Option C (OP.C); Option D (OP.D); Option E (OP.E); Absolute battery

Specify various controller setting items. RCX340 ▶ **P.542**

RCX240S

Controller: RCX240S; CE Marking; Expansion I/O; Network option; IVY System; Gripper; Battery

Specify various controller setting items. RCX240/RCX240S ▶ **P.532**

Basic specifications

	X axis	Y axis	Z axis	R axis
Axis specifications				
Arm length (mm)	250	150	150	-
Rotation angle (°)	+/-129	+/-144	-	+/-360
AC servo motor output (W)	200	150	50	100
Repeatability ^{Note 1} (XYZ: mm) (R: °)	+/-0.01		+/-0.01	+/-0.004
Maximum speed (XYZ: m/sec) (R: °/sec)	6.1		1.1	1020
Maximum payload (kg)	4			
Standard cycle time: with 2kg payload (sec) ^{Note 2}	0.57			
R-axis tolerable moment of inertia ^{Note 3} (kgm ²)	0.05			
User wiring (sq x wires)	0.2x10			
User tubing (Outer diameter)	φ4x4			
Travel limit	1.Soft limit, 2.Mechanical stopper (X, Y, Z axes)			
Robot cable length (m)	Standard: 3.5 Option: 5, 10			
Weight (kg)	22.5			
Degree of cleanliness	ISO CLASS 3 (ISO 14644-1) ^{Note 4+ESD} ^{Note 5}			
Intake air (Nl/min)	30 ^{Note 6}			

Controller

Controller	Power capacity (VA)	Operation method
RCX340 RCX240S	1000	Programming / I/O point trace / Remote command / Operation using RS-232C communication

Note. "Harmonic" and "Harmonic drive" are the registered trademarks of Harmonic Drive Systems Inc.
 Note. The movement range can be limited by changing the positions of X and Y axis mechanical stoppers. (The movement range is set to the maximum at the time of shipment.)
 See our robot manuals (installation manuals) for detailed information.
 Note. To set the standard coordinates with high accuracy, use a standard coordinate setting jig (option). Refer to the user's manual (installation manual) for more details.

Our robot manuals (installation manuals) can be downloaded from our website at the address below:
<http://global.yamaha-motor.com/business/robot/>

Note 1. This is the value at a constant ambient temperature. (X,Y axes)
 Note 2. When reciprocating 25mm in vertical direction and 300mm in horizontal direction (rough-positioning arch motion).
 Note 3. There are limits to acceleration coefficient settings. See P.608.
 Note 4. Class 10 (0.1µm) equivalent to FED-STD-209D
 Note 5. ESD (ElectroStatic Discharge) prevention is an option. Please contact our distributor.
 Note 6. The necessary intake amount varies depending on the use conditions and environment.

YK400XGC

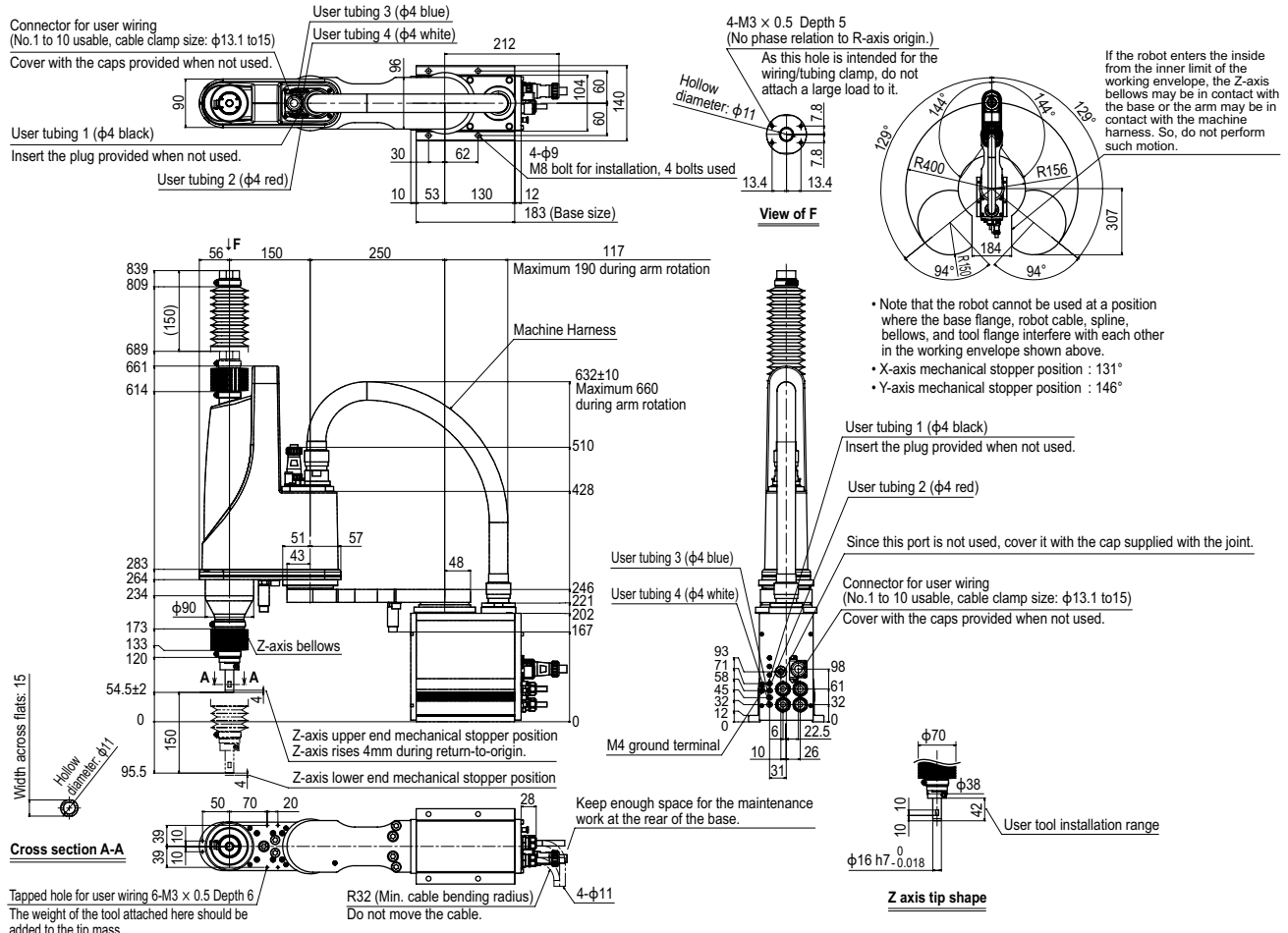

YK500XGLC Tool flange mount type

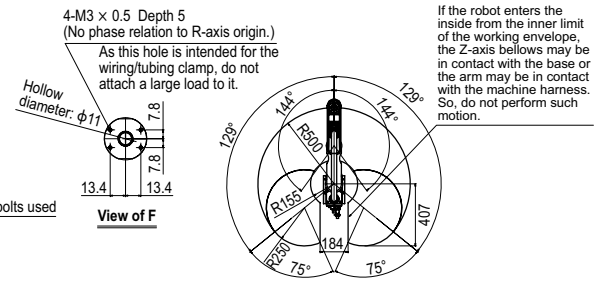
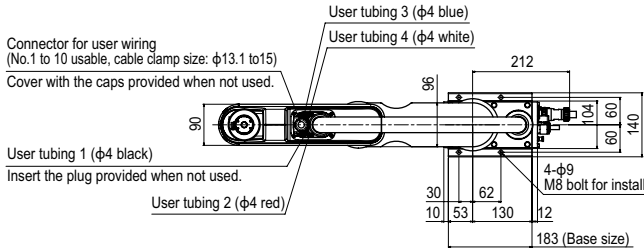

If the robot enters the inside from the inner limit of the working envelope, the Z-axis bellows may be in contact with the base or the arm may be in contact with the machine harness. So, do not perform such motion.

- Note that the robot cannot be used at a position where the base flange, robot cable, spline, bellows, and tool flange interfere with each other in the working envelope shown above.
- X-axis mechanical stopper position : 131°
- Y-axis mechanical stopper position : 146°

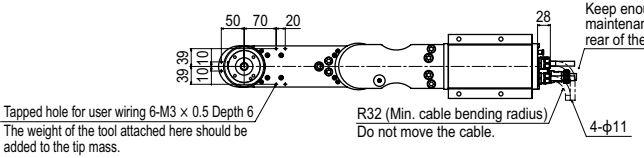
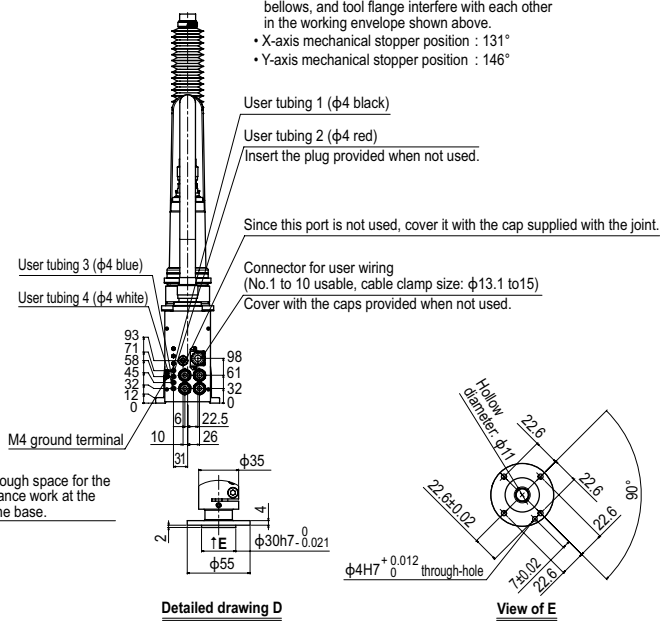
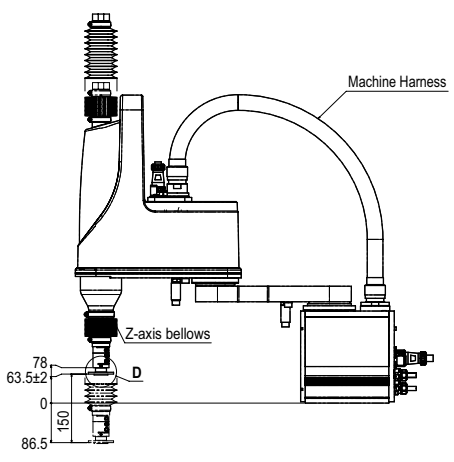

YK500XC

● Arm length 500mm ● Maximum payload 10kg



Ordering method

YK500XC **RCX340-4**

Model	Z axis stroke	Cable length	Controller / Number of controllable axes	Safety standard	Option A (OP.A)	Option B (OP.B)	Option C (OP.C)	Option D (OP.D)	Option E (OP.E)	Absolute battery
	200: 200mm 300: 300mm	3L: 3.5m 5L: 5m 10L: 10m								

Specify various controller setting items. RCX340 ▶ **P.542**

RCX240 **R**

Controller	CE Marking	Regenerative unit	Expansion I/O	Network option	IVY System	Gripper	Battery

Specify various controller setting items. RCX240/RCX240S ▶ **P.532**

Basic specifications

Axis specifications	Arm length (mm)	X axis	Y axis	Z axis		R axis
		Rotation angle (°)				
		250	250	200	300	-
		+/-120	+/-142	-	-	+/-180
AC servo motor output (W)		400	200	200	100	100
Repeatability ^{Note 1} (XYZ: mm) (R: °)		+/-0.02		+/-0.01	+/-0.005	
Maximum speed (XYZ: m/sec) (R: °/sec)		4.9		1.7	876	
Maximum payload (kg)		10				
Standard cycle time: with 2kg payload (sec)		0.53				
R-axis tolerable moment of inertia ^{Note 2} (kgm ²)		0.12				
User wiring (sq x wires)		0.2 x 20				
User tubing (Outer diameter)		φ6 x 3				
Travel limit		1.Soft limit, 2.Mechanical stopper (X, Y, Z axes)				
Robot cable length (m)		Standard: 3.5 Option: 5, 10				
Weight (kg)		31				
Degree of cleanliness		CLASS 10 ^{Note 3}				
Intake air (Nl/min)		60 ^{Note 4}				

Note 1. This is the value at a constant ambient temperature. (X,Y axes)
 Note 2. There are limits to acceleration coefficient settings.
 Note 3. Per 1cf (0.1μm base), when suction blower is used.
 Note 4. The necessary intake amount varies depending on the use conditions and environment.

Controller

Controller	Power capacity (VA)	Operation method
RCX340 RCX240-R	1500	Programming / I/O point trace / Remote command / Operation using RS-232C communication

Note. "Harmonic" and "Harmonic drive" are the registered trademarks of Harmonic Drive Systems Inc.

Note. The movement range can be limited by changing the positions of X and Y axis mechanical stoppers. (The movement range is set to the maximum at the time of shipment.) See our robot manuals (installation manuals) for detailed information.

Our robot manuals (installation manuals) can be downloaded from our website at the address below:
<http://global.yamaha-motor.com/business/robot/>

YK500XC

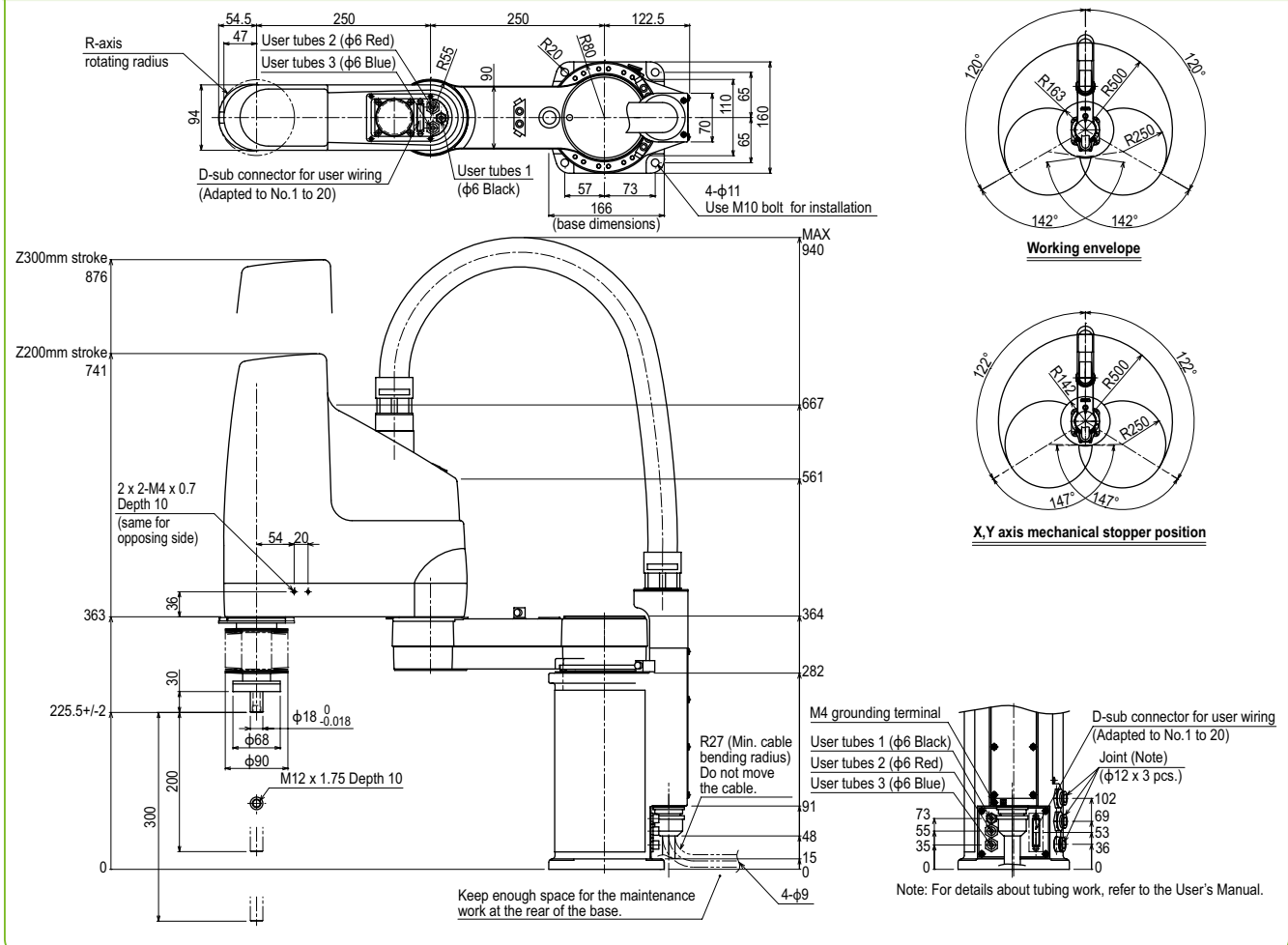

YK600XGLC

● Arm length 600mm ● Maximum payload 4kg

Ordering method

YK600XGLC - 150

Model	Z axis stroke 150: 150mm	Tool flange No entry: None F: With tool flange	Hollow shaft S: With hollow shaft	Cable length 3L: 3.5m 5L: 5m 10L: 10m
--------------	------------------------------------	---	---	---

S

RCX340-4

Controller / Number of controllable axes	Safety standard	Option A (OP.A)	Option B (OP.B)	Option C (OP.C)	Option D (OP.D)	Option E (OP.E)	Absolute battery
---	------------------------	------------------------	------------------------	------------------------	------------------------	------------------------	-------------------------

RCX240S

Controller	CE Marking	Expansion I/O	Network option	IVY System	Gripper	Battery
-------------------	-------------------	----------------------	-----------------------	-------------------	----------------	----------------

Specify various controller setting items. RCX340 ▶ **P.542**

Specify various controller setting items. RCX240/RCX240S ▶ **P.532**

Basic specifications

Axis specifications	Arm length (mm)	X axis	Y axis	Z axis	R axis
	350	350	250	150	-
	Rotation angle (°)	+/-129	+/-144	-	+/-360
AC servo motor output (W)		200	150	50	100
Repeatability^{Note 1} (XYZ: mm) (R: °)		+/-0.01		+/-0.01	+/-0.004
Maximum speed (XYZ: m/sec) (R: °/sec)		4.9		1.1	1020
Maximum payload (kg)		4			
Standard cycle time: with 2kg payload (sec)^{Note 2}		0.74			
R-axis tolerable moment of inertia^{Note 3} (kgm²)		0.05			
User wiring (sq x wires)		0.2x10			
User tubing (Outer diameter)		φ4x4			
Travel limit		1.Soft limit, 2.Mechanical stopper (X, Y, Z axes)			
Robot cable length (m)		Standard: 3.5 Option: 5, 10			
Weight (kg)		26			
Degree of cleanliness		ISO CLASS 3 (ISO 14644-1) ^{Note 4} +ESD ^{Note 5}			
Intake air (Nl/min)		30 ^{Note 6}			

- Note 1. This is the value at a constant ambient temperature. (X,Y axes)
 Note 2. When reciprocating 25mm in vertical direction and 300mm in horizontal direction (rough-positioning arch motion).
 Note 3. There are limits to acceleration coefficient settings. See P.608.
 Note 4. Class 10 (0.1µm) equivalent to FED-STD-209D
 Note 5. ESD (ElectroStatic Discharge) prevention is an option. Please contact our distributor.
 Note 6. The necessary intake amount varies depending on the use conditions and environment.

Controller

Controller	Power capacity (VA)	Operation method
RCX340 RCX240S	1000	Programming / I/O point trace / Remote command / Operation using RS-232C communication

- Note. "Harmonic" and "Harmonic drive" are the registered trademarks of Harmonic Drive Systems Inc.
 Note. The movement range can be limited by changing the positions of X and Y axis mechanical stoppers. (The movement range is set to the maximum at the time of shipment.)
 See our robot manuals (installation manuals) for detailed information.
 Note. To set the standard coordinates with high accuracy, use a standard coordinate setting jig (option). Refer to the user's manual (installation manual) for more details.

Our robot manuals (installation manuals) can be downloaded from our website at the address below:
<http://global.yamaha-motor.com/business/robot/>

YK600XGLC

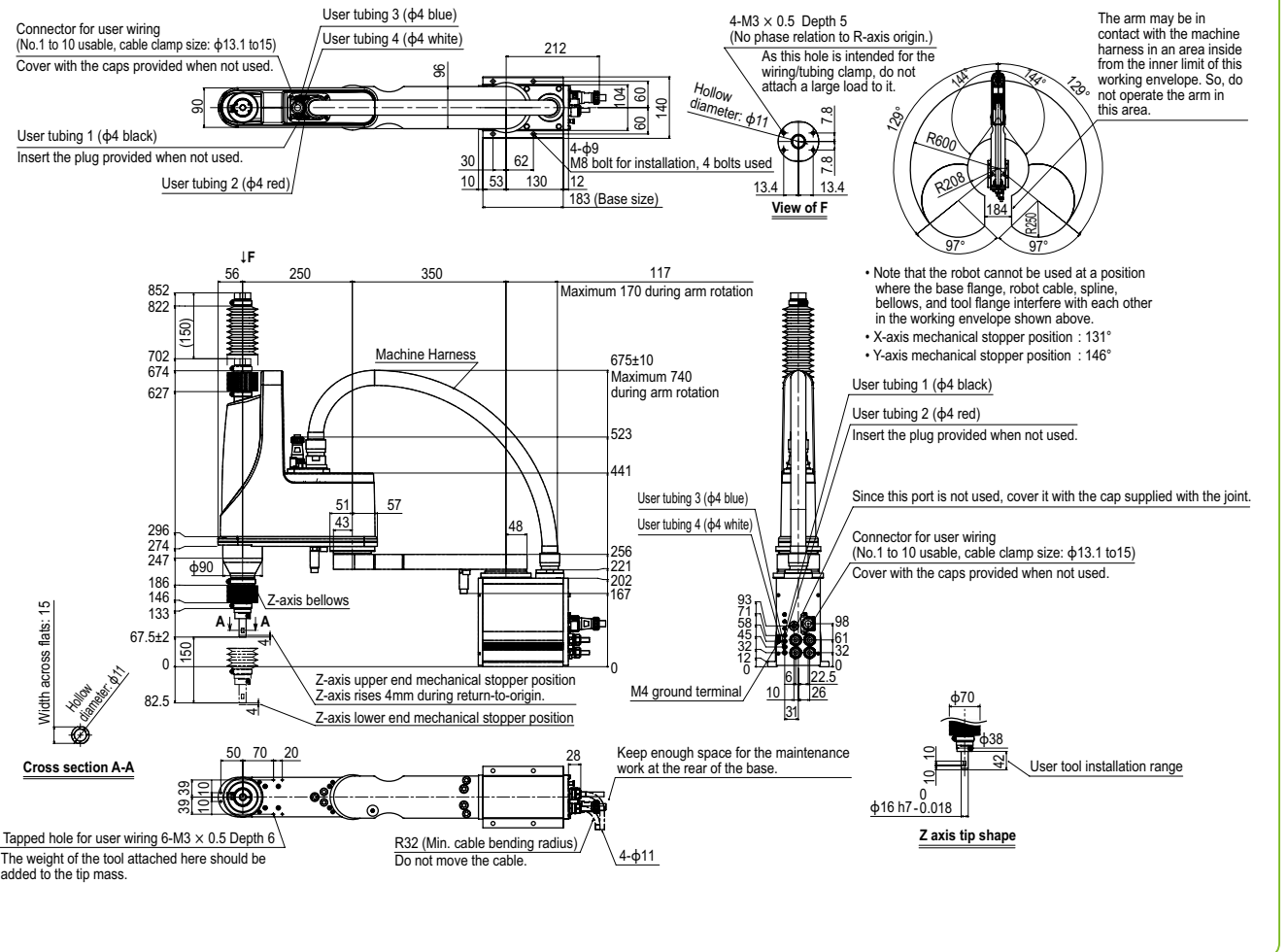

Articulated robots
YA

Linear conveyor modules
LCM100

Compact single-axis robots
TRANSERVO

Single-axis robots
FLIP-X

Linear motor single-axis robots
PHASER

Cartesian robots
XX-X

SCARA robots
YK-X

Pick & place robots
YP-X

CLEAN

CONTROLLER INFORMATION

Single-axis
Cartesian

SCARA

Articulated robots
YA

Linear conveyor modules
LCM100

Compact single-axis robots
TRANSEVO

Single-axis robots
FLIP-X

Linear motor single-axis robots
PHASER

Cartesian robots
XY-X

SCARA robots
YK-X

Pick & place robots
YP-X

CLEAN

CONTROLLER INFORMATION

Single-axis

Cartesian

SCARA

YK600XGLC Tool flange mount type

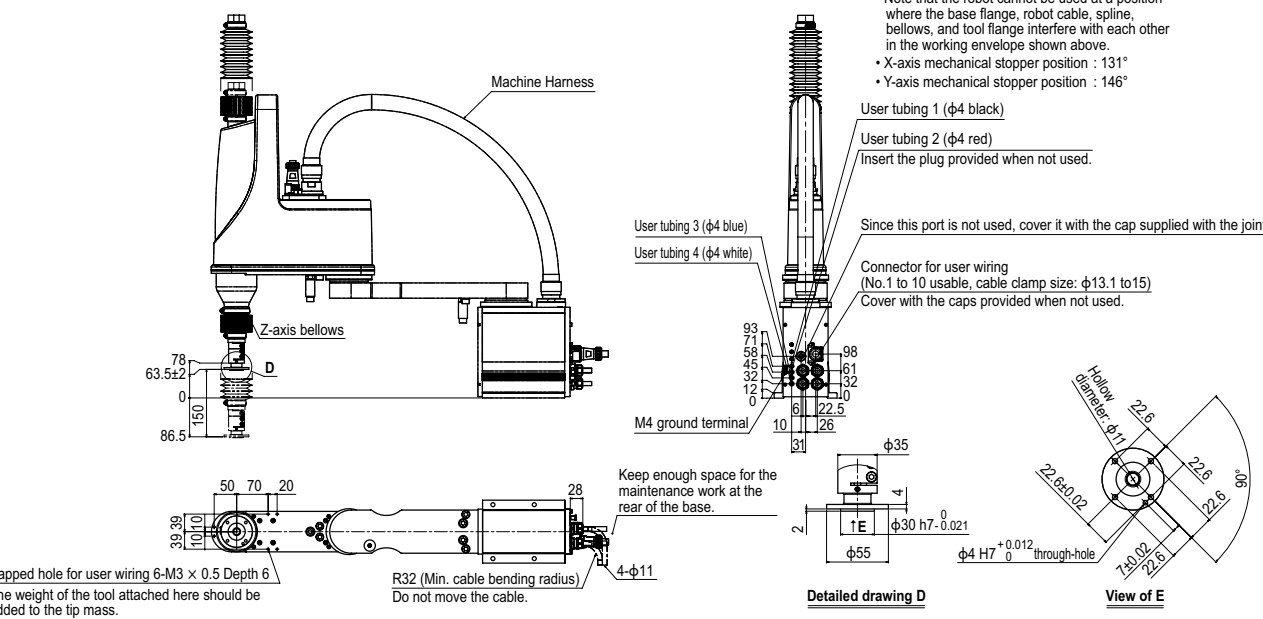
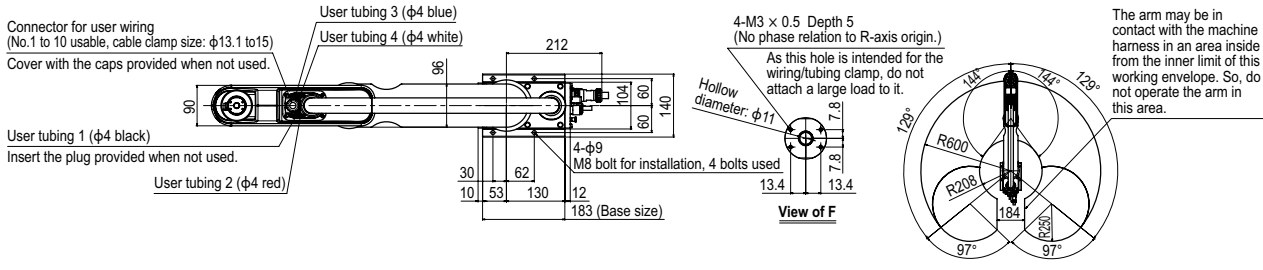

YK600XC

● Arm length 600mm ● Maximum payload 10kg



Ordering method

YK600XC [] [] **RCX340-4** [] [] [] [] [] [] [] [] [] []

Model Z axis stroke Cable length Controller / Number of controllable axes Safety standard Option A (OP.A) Option B (OP.B) Option C (OP.C) Option D (OP.D) Option E (OP.E) Absolute battery

Z axis stroke: 200: 200mm, 300: 300mm
Cable length: 3L: 3.5m, 5L: 5m, 10L: 10m

Specify various controller setting items. RCX340 ▶ P.542

RCX240 [] **R** [] [] [] [] [] [] [] [] [] []

Controller CE Marking Regenerative unit Expansion I/O Network option iVY System Gripper Battery

Specify various controller setting items. RCX240/RCX240S ▶ P.532

Basic specifications

Axis specifications	Arm length (mm)	X axis	Y axis	Z axis	R axis
Rotation angle (°)		+/-120	+/-145	-	+/-180
AC servo motor output (W)		400	200	200	100
Repeatability ^{Note 1} (XYZ: mm) (R: °)		+/-0.02		+/-0.01	+/-0.005
Maximum speed (XYZ: m/sec) (R: °/sec)		5.6		1.7	876
Maximum payload (kg)		10			
Standard cycle time: with 2kg payload (sec)		0.56			
R-axis tolerable moment of inertia ^{Note 2} (kgm ²)		0.12			
User wiring (sq x wires)		0.2 x 20			
User tubing (Outer diameter)		φ6 x 3			
Travel limit		1.Soft limit, 2.Mechanical stopper (X, Y, Z axes)			
Robot cable length (m)		Standard: 3.5 Option: 5, 10			
Weight (kg)		33			
Degree of cleanliness		CLASS 10 ^{Note 3}			
Intake air (Nl/min)		60 ^{Note 4}			

Note 1. This is the value at a constant ambient temperature. (X, Y axes)
 Note 2. There are limits to acceleration coefficient settings.
 Note 3. Per 1cf (0.1μm base), when suction blower is used.
 Note 4. The necessary intake amount varies depending on the use conditions and environment.

Controller

Controller	Power capacity (VA)	Operation method
RCX340 RCX240-R	1500	Programming / I/O point trace / Remote command / Operation using RS-232C communication

Note. "Harmonic" and "Harmonic drive" are the registered trademarks of Harmonic Drive Systems Inc.
 Note. The movement range can be limited by changing the positions of X and Y axis mechanical stoppers. (The movement range is set to the maximum at the time of shipment.)
 See our robot manuals (installation manuals) for detailed information.

Our robot manuals (installation manuals) can be downloaded from our website at the address below:
<http://global.yamaha-motor.com/business/robot/>

YK600XC

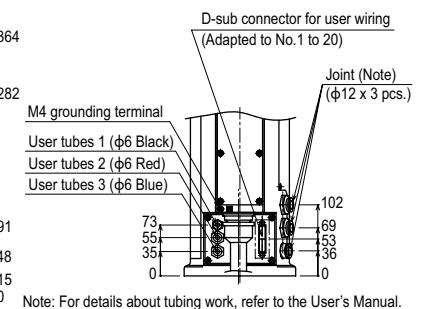
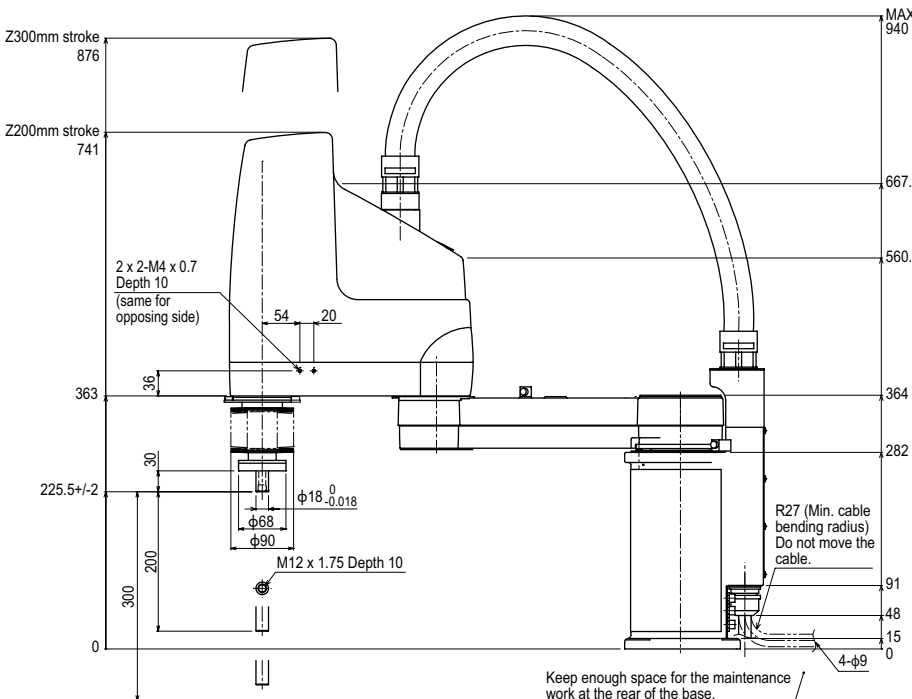
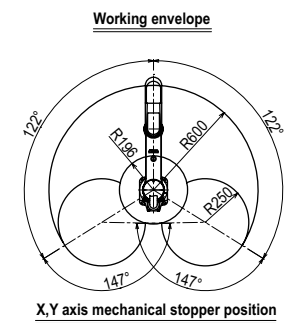
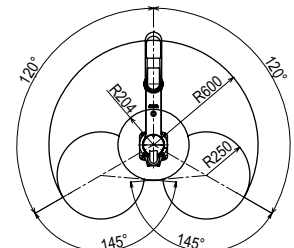
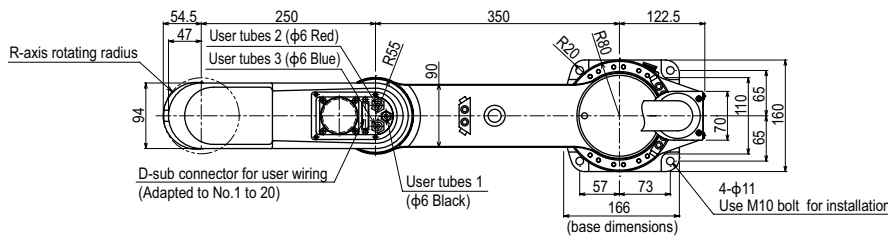

Note: For details about tubing work, refer to the User's Manual.

Articulated robots
YA

Linear conveyor modules
LCM100

Compact single-axis robots
TRANSEVO

Single-axis robots
FLIP-X

Linear motor single-axis robots
PHASER

Cartesian robots
XX-X

SCARA robots
YK-X

Pick & place robots
YP-X

CLEAN

CONTROLLER INFORMATION

Single-axis
Cartesian

SCARA

YK700XC

● Arm length 700mm ● Maximum payload 20kg



Ordering method

YK700XC [] [] **RCX340-4** [] [] [] [] [] [] [] [] []

Model Z axis stroke Cable length Controller / Number of controllable axes Safety standard Option A (OP.A) Option B (OP.B) Option C (OP.C) Option D (OP.D) Option E (OP.E) Absolute battery

Z axis stroke: 200: 200mm, 400: 400mm
Cable length: 3L: 3.5m, 5L: 5m, 10L: 10m

Specify various controller setting items. RCX340 ▶ P.542

RCX240 [] [] **R** [] [] [] [] [] [] [] [] []

Controller CE Marking Regenerative unit Expansion I/O Network option iVY System Gripper Battery

Specify various controller setting items. RCX240/RCX240S ▶ P.532

Basic specifications

Axis specifications	Arm length (mm)	X axis	Y axis	Z axis	R axis
Rotation angle (°)		+/-120	+/-145	-	+/-180
AC servo motor output (W)		800	400	400	200
Repeatability ^{Note 1} (XYZ: mm) (R: °)		+/-0.02		+/-0.01	+/-0.005
Maximum speed (XYZ: m/sec) (R: °/sec)		6.7		1.7	600
Maximum payload (kg)		20			
Standard cycle time: with 2kg payload (sec)		0.57			
R-axis tolerable moment of inertia ^{Note 2} (kgm ²)		0.32			
User wiring (sq x wires)		0.2 x 20			
User tubing (Outer diameter)		φ6 x 3			
Travel limit		1.Soft limit, 2.Mechanical stopper (X, Y, Z axes)			
Robot cable length (m)		Standard: 3.5 Option: 5, 10			
Weight (kg)		57			
Degree of cleanliness		CLASS 10 ^{Note 3}			
Intake air (Nl/min)		60 ^{Note 4}			

Note 1. This is the value at a constant ambient temperature. (X,Y axes)
 Note 2. There are limits to acceleration coefficient settings.
 Note 3. Per 1cf (0.1μm base), when suction blower is used.
 Note 4. The necessary intake amount varies depending on the use conditions and environment.

Controller

Controller	Power capacity (VA)	Operation method
RCX340 RCX240-R	2000	Programming / I/O point trace / Remote command / Operation using RS-232C communication

Note. "Harmonic" and "Harmonic drive" are the registered trademarks of Harmonic Drive Systems Inc.

Note. The movement range can be limited by changing the positions of X and Y axis mechanical stoppers. (The movement range is set to the maximum at the time of shipment.)
 See our robot manuals (installation manuals) for detailed information.

Our robot manuals (installation manuals) can be downloaded from our website at the address below:
<http://global.yamaha-motor.com/business/robot/>

YK700XC

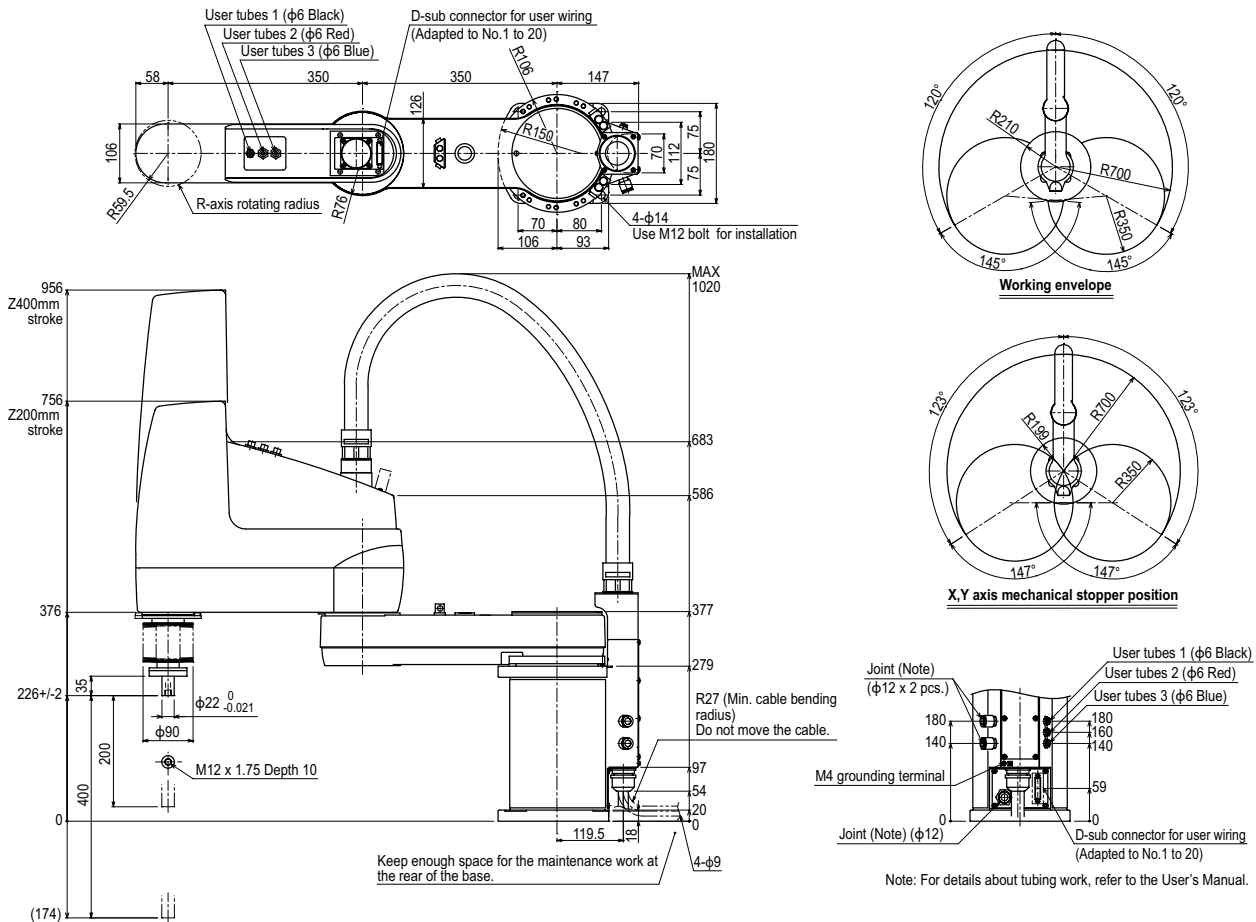

YK800XC

● Arm length 800mm ● Maximum payload 20kg



Ordering method

YK800XC

Model	Z axis stroke 200: 200mm 400: 400mm	Cable length 3L: 3.5m 5L: 5m 10L: 10m	RCX340-4							
			Controller / Number of controllable axes	Safety standard	Option A (OP.A)	Option B (OP.B)	Option C (OP.C)	Option D (OP.D)	Option E (OP.E)	Absolute battery

Specify various controller setting items. RCX340 ▶ **P.542**

RCX240

Controller	CE Marking	Regenerative unit	Expansion I/O	Network option	IVY System	Gripper	Battery
------------	------------	-------------------	---------------	----------------	------------	---------	---------

Specify various controller setting items. RCX240/RCX240S ▶ **P.532**

Basic specifications

	X axis	Y axis	Z axis	R axis
Axis specifications				
Arm length (mm)	450	350	200 400	-
Rotation angle (°)	+/-120	+/-145	-	+/-180
AC servo motor output (W)	800	400	400	200
Repeatability ^{Note 1} (XYZ: mm) (R: °)	+/-0.02		+/-0.01	+/-0.005
Maximum speed (XYZ: m/sec) (R: °/sec)	7.3		1.7	600
Maximum payload (kg)	20			
Standard cycle time: with 2kg payload (sec)	0.57			
R-axis tolerable moment of inertia ^{Note 2} (kgm ²)	0.32			
User wiring (sq x wires)	0.2 x 20			
User tubing (Outer diameter)	φ6 x 3			
Travel limit	1.Soft limit, 2.Mechanical stopper (X, Y, Z axes)			
Robot cable length (m)	Standard: 3.5 Option: 5, 10			
Weight (kg)	58			
Degree of cleanliness	CLASS 10 ^{Note 3}			
Intake air (Nl/min)	60 ^{Note 4}			

Note 1. This is the value at a constant ambient temperature. (X,Y axes)
 Note 2. There are limits to acceleration coefficient settings.
 Note 3. Per 1cf (0.1μm base), when suction blower is used.
 Note 4. The necessary intake amount varies depending on the use conditions and environment.

Controller

Controller	Power capacity (VA)	Operation method
RCX340 RCX240-R	2000	Programming / I/O point trace / Remote command / Operation using RS-232C communication

Note. "Harmonic" and "Harmonic drive" are the registered trademarks of Harmonic Drive Systems Inc.

Note. The movement range can be limited by changing the positions of X and Y axis mechanical stoppers. (The movement range is set to the maximum at the time of shipment.) See our robot manuals (installation manuals) for detailed information.

Our robot manuals (installation manuals) can be downloaded from our website at the address below:
<http://global.yamaha-motor.com/business/robot/>

YK800XC

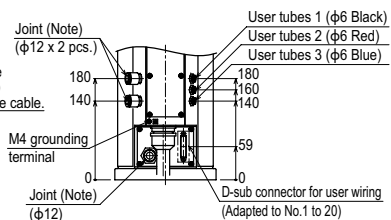
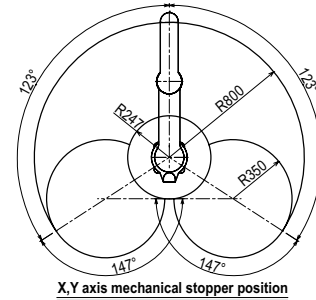
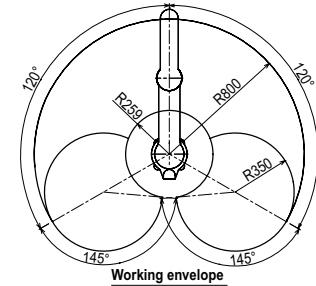
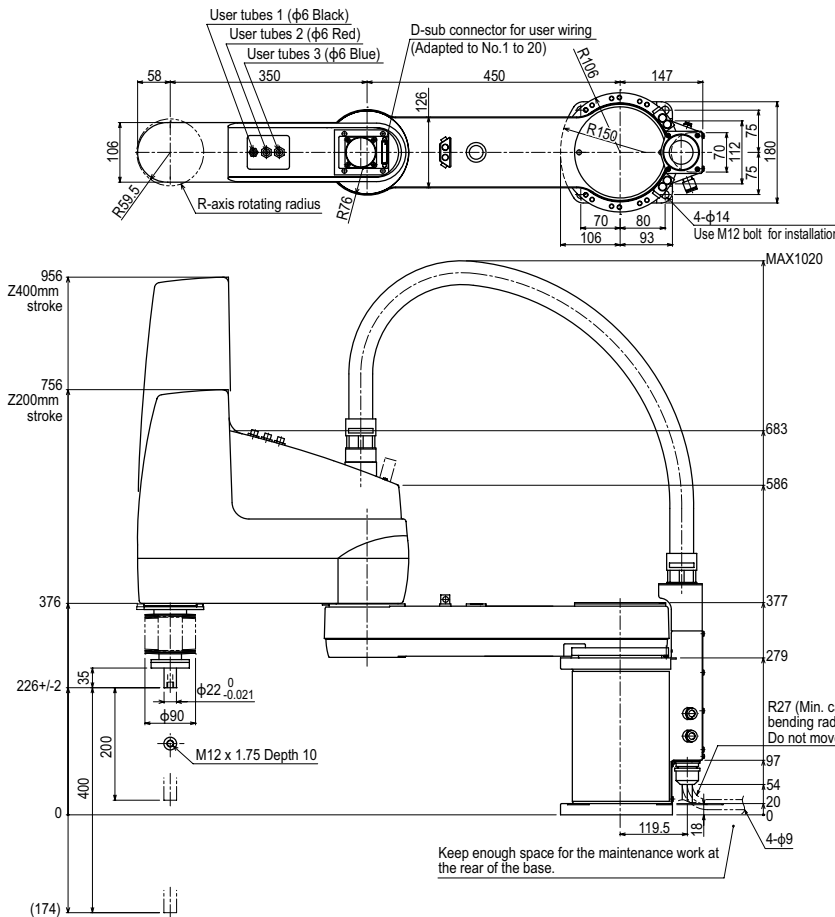

Note: For details about tubing work, refer to the User's Manual.

Articulated robots
YA

Linear conveyor modules
LCM100

Compact single-axis robots
TRANSEVO

Single-axis robots
FLIP-X

Linear motor single-axis robots
PHASER

Cartesian robots
XX-X

SCARA robots
YK-X

Pick & place robots
YP-X

CLEAN

CONTROLLER INFORMATION

Single-axis
Cartesian

SCARA

