

Chantey

NEWSLETTER FOR YAMAHA MARINE DEALERS

March 2017

No. 163

English Version



CONTENTS

P1: Chantey Special: New 4-stroke Outboards Have Arrived!

P3: One-point Service Advice: Points for Proper Wiring

P5: Kurt Goes Fishing Down Under: About My Boat

News Round-up: WaveRunner Instructor Training and Safety Riding Courses Held in Bahrain and more

YAMAHA MOTOR CO., LTD., Marine Business Operations, 2500 Shingai, Iwata, Shizuoka 438-8501, Japan

New 4-stroke Outboards Have Arrived! Featuring the F25G, F90C/F100F and F250H

Yamaha's latest additions to the outboard lineup are here! We briefly introduce the three new models and their main features in this issue of *Chantey*.

Our new F25G 25-horsepower 4-stroke model was the result of a dedicated pursuit of the performance and usability desired in a portable outboard. The new F90C and F100F were based on the popular F115B model but newly developed for even greater weight reductions and compactness. Finally, the 250-horsepower F250H model features a much more durable gear assembly to make it capable of commercial use.

Yamaha will continue its work every year to enhance the performance of its outboards and diversify the lineup according to market and user needs.

F25G

Light, Compact and Quick to Start-Up

The new F25G is powered by a 4-stroke 432cc in-line two-cylinder SOHC engine developed under the concept of ensuring reliable engine start-ups in a lightweight, compact package adapted from a 2-stroke model. Its small and lightweight design is its primary feature, with approximately 20 kg less weight than the previous F25D model. This makes it the industry's lightest outboard available in the 4-stroke 25 horsepower class! Battery-less fuel injection has been newly incorporated into the fuel delivery system to achieve class-leading acceleration and stable engine-starting performance even in harsh environments.

Main Features

- Compact size
- Light weight
- Battery-less fuel injection
- Multi-function tiller handle
- New carrying grip and handle
- Variable trolling speed switch
- Customizability

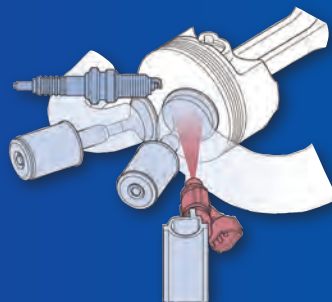

Battery-less fuel injection

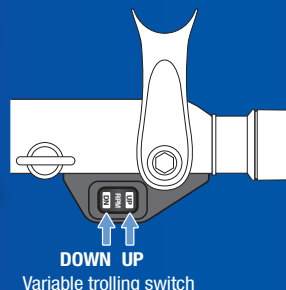

DOWN UP
Variable trolling switch

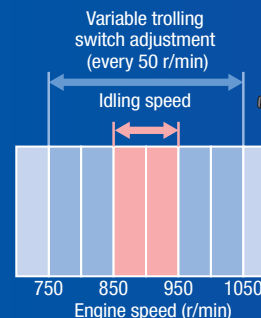

1

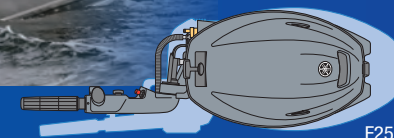

F25G

F25D

*Chantey
Special*

New 4-stroke Outboards Have Arrived! Featuring the F25G, F90C/F100F and F250H

F90C/F100F

High Performance for a Wide Range of Uses

The new F90C and F100F are equipped with a 4-stroke, 4-cylinder 16-valve in-line SOHC 1,832cc engine. While following the design of the next-generation F115B and F200F, we have downsized the power unit for an even more compact design. Besides having less vibration and engine noise at low operating speeds, the F90C/F100F have various sensors located throughout the engine and, together with the ECM (engine control module) settings and other measures, allows for precise control of fuel injection volume, injection timing and ignition timing. This helps reduce fuel consumption by about 10% at mid-range speeds compared to the previous F90B. As these outboards can be mounted in the same way as outboards of a similar size, the F90C/F100F are a great choice for making the switch to an economical 4-stroke engine.

- Main Features
- Reduced weight and size
 - Better fuel consumption
 - Improved serviceability
 - Multi-point fuel injection
 - ECU control system
 - Variable trolling switch

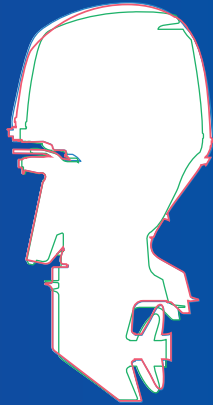
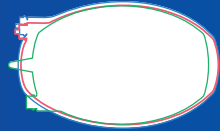

- F90B
- F115B
- F90C

F250H *Commercial*

Stronger, More Durable Gears

The F250H is powered by a 4-stroke 3,352cc DOHC V6 24-valve engine and takes the F250G/FL250G as its base. This version of the popular outboard features a much more durable gear assembly in the lower unit to make it suitable for the demands of commercial use. The graphics on the powerhead also indicate that this is a model for commercial-use only.

Main Features

- New and thicker gears with 26/13 gear teeth
- Tooth contact (surface pressure and bending stress) improved
- Forward gear bush changed to a needle bearing to reduce friction loss (regular rotation spec)
- Vacuum carbonitriding heat treatment employed

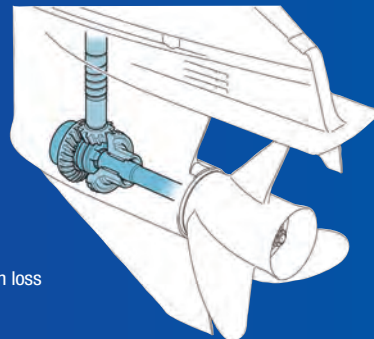

Points for Proper Wiring

When rigging a boat with navigational equipment and other electrical/electronic devices on-site, there may be times when you have to do some of the wiring yourself. Wiring can be done in any number of ways, but you have to always keep in mind that random or unsuitable wiring methods can lead to problems like shorts, breakage and overheating. These in turn can cause serious accidents like fires or equipment failure. However, if you understand the important points of wiring work, you can set up the wiring to be reliable and look neat too, even without detailed instructions. Let's go over some especially important points of wiring when working on-site.



Basic Rules of Wiring

1. No rubbing or breaks

Causes

- Contact with sharp edges
- Being stepped on
- Contact with high temperatures
- Subjected to repetitive motion and stresses
- Being stretched or catching on something



2. No loose connections, no coming loose

Causes

- Stretching
- Catching on something



3. No contact with water

Causes

- Bilge water build-up
- Wires running through water



4. Minimize damage in worst case scenarios

Cause

- Unsafe positioning of wiring around the fuel and hydraulic lines

5. Easy to maintain

- Make wiring easy to find
- Make wiring easy to inspect and/or replace

6. Make the wiring look neatly done

Wiring Inside a Storage Compartment

It is generally best to avoid running wiring through a storage compartment, but when it can't be avoided, do it as shown below.

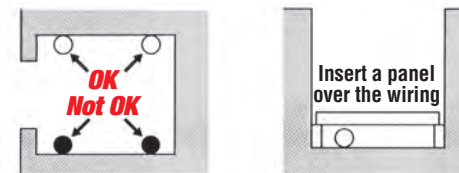

Caution: Owners may put any number of different objects in a storage compartment without sufficient care, and there is the possibility of these stored items causing damage to the wiring harness(es), so perform the wiring work with that in mind.

Fastening a Wiring Harness

Fasten a harness in place using clamps suitable for the harness' diameter. When doing so, make sure the interval between the clamps is no more than 40 cm.

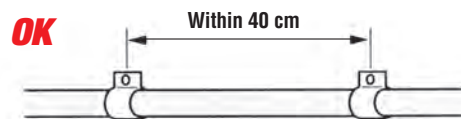

Caution: If the harness is not fastened in place, vibration can cause wear, etc., that can damage the harness, so be sure to always fasten harnesses firmly in place.

Never Force Tension on a Harness

Always allow a good amount of play in the wiring near its terminal.

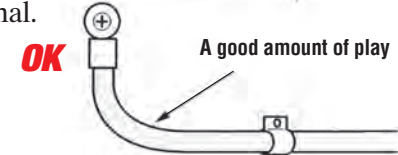

Caution: If wiring is done with tension on the harness, it can result in damage to the terminal or possibly cause connectors to come loose (disconnect).

Preventing Interference by Sharp Edges

Caution: If the wiring (harness) is run around sharper edges of the boat (hull) or peripheral equipment without sufficient countermeasures, these edges can damage the wire coating and possibly lead to shorts or breakage, so take due care when routing the wires around them.

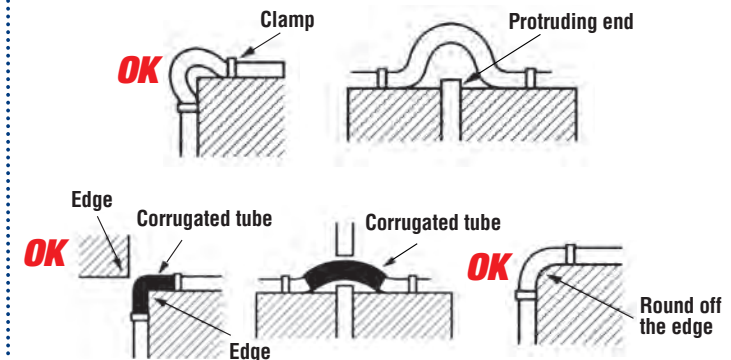

One-point Service Advice

Separate the Electrical Wiring from Fuel and Hydraulic Lines

In case some sort of trouble causes sparking or burning of the electrical wiring harness, the wiring should be separated as much as possible from the fuel or hydraulic lines to prevent them from catching fire.

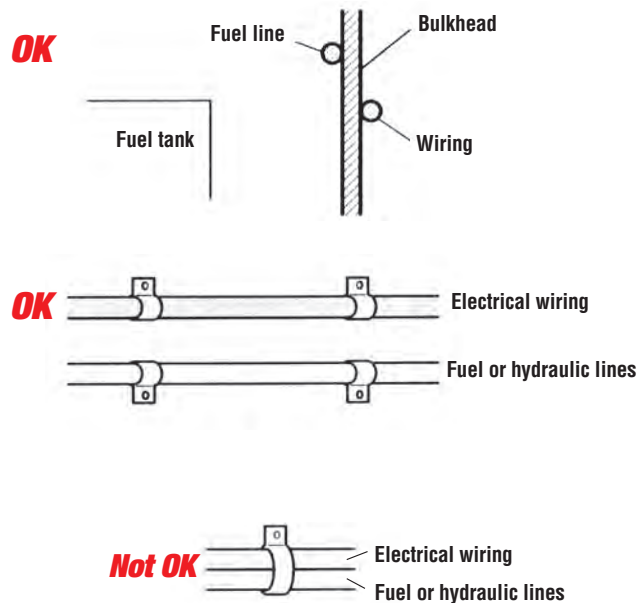

Caution: Position the electrical wiring higher than the fuel and hydraulic lines as much as possible. If the fuel or hydraulic lines are positioned above the wiring and a leakage occurs, the fuel or hydraulic fluid could hit the wiring and increase the risk of fire breaking out.

Protection from Water

Do not to run electrical wiring (wiring harness, battery cables) through areas of the boat where water accumulates (bilge area).

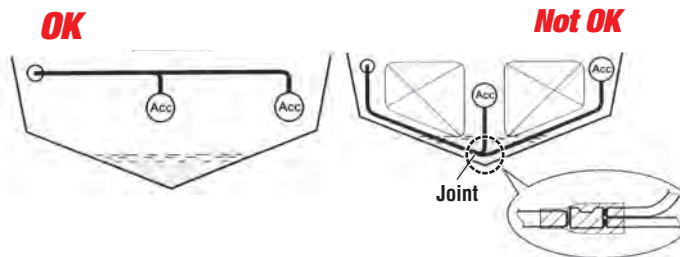

Caution: When electrical wiring gets wet it can cause trouble like poor connections, corrosion and leaks, so take extra precautions to keep the wiring out of water.

Prevent Damage from Wires Being Stepped On

Caution: Be aware of the possibility of wiring and harnesses being damaged by being stepped on when people enter the engine or steering compartments, etc., for servicing or inspections, and route the wires accordingly.

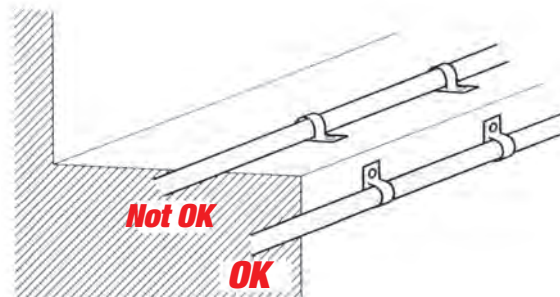

Never Run Wiring Across Moving Parts

- 1) Do not clamp wiring harnesses to moving parts.
- 2) Do not run wiring through places where moving parts may make contact with it.
- 3) Do not allow coiling at the wire terminals.

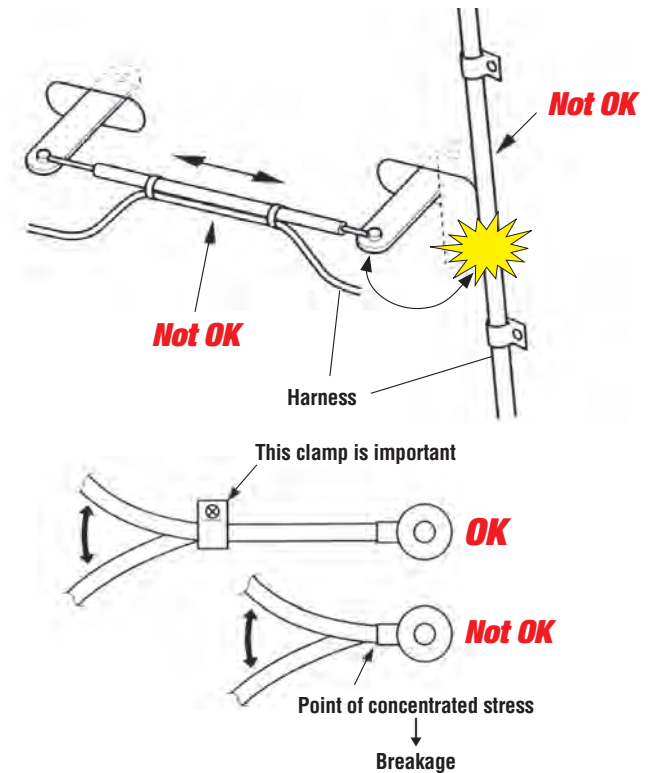

Caution: Fastening wiring harnesses to moving parts subjects the wiring to repetitive motion and stresses that can soon result in wire breakage. Also, when wiring comes into contact with moving parts, it becomes more susceptible to wear and possibly being caught in or on something, so take additional care when routing wiring through areas with moving parts.



Kurt Goes Fishing Down Under

Hi, everybody! It's Kurt again. I was re-assigned to a post at Yamaha Motor Australia, so I moved to Brisbane! From this issue of *Chantey* I'll be introducing a series of articles over the year about boating and fishing here in Australia.

About My Boat Australia Entry #1

Australia is one of the most popular countries in the world for boating and many Australians have their own boats that they use for fishing and watersports. Particularly, in the State of Queensland, the coastline is dotted with calm-water bays, so there are many waters where you can have fun even with a relatively small boat. For these reasons, a wide variety of craft are sold in Australia, ranging from large luxury yachts to small, reasonably priced boats. Since owning my own boat has long been a personal dream of mine, I decided that this would finally be my chance to make that dream come true.

Trailer-able aluminum boats mounting an outboard motor are the most popular type of private boat in Australia; about 80% of the boats here are aluminum boats. The model I chose for my first boat from among the many available is a Sea Jay 4.48 Avenger Sports.

Sea Jay is a Queensland boatbuilder that is an attractive choice not only for their high quality products but also because they will customize their boats according to customer preferences. Through my local Yamaha dealership, I had a console installed and other customizations made to fit my fishing style. I chose the reliable 4-stroke F60 for the motor, and I outfitted the boat with the latest full-color 6YC gauge, a 12-inch GPS fish-finder and an electric trolling motor to make it a high-

performance fishing boat despite its small size.

Once I got my boat, I was naturally anxious to get out fishing as soon as possible, but there was something I had to do first—breaking in the engine, of course. The way to break in the engine is written in the Owner's Manual that comes with it, so I won't go over the process here, but it's important to note that a proper break-in of the engine helps bring out its true performance and extends the life of the engine as well. So when you buy a new outboard or sell a new one to a customer, I strongly encourage you to perform or recommend conducting the break-in correctly. Well, once the break-in period was finished I was ready to go out fishing! In my next entry, I'll start introducing the many joys of fishing in Australia.

Kurt Takayanagi, YMA



News Round-up

Activities from distributors around the world, and more

WaveRunner Instructor Training and Safety Riding Courses Held in Bahrain

Yamaha Motor's distributor in Bahrain, AJM Kooheji Group B.S.C. (c), held WaveRunner YRA Area Instructor Training Courses and Safety Riding Courses over the four days (1–2, 4–5) in early October 2016 in the capital of Manama.

On the first day of October 1st, the YMC Master Instructor gave seven of the distributor's staff an Area Instructor Training Course, which includes both classroom study and hands-on training with the WaveRunners.

The next day, eight experienced members of the Bahrain Coast Guard's diving-rescue team were given a WaveRunner YRA Safety Riding Course to help them educate newer members more effectively in classroom sessions and on-water training.

For the two days of October 4th and 5th, WaveRunner YRA Safety Riding Courses were held for a total of 29 marine club staff of large hotels and PWC rental operators. The classroom sessions and on-water training were aimed at preparing the participants to give proper instructions and safety advice to customers renting a PWC for the first time.

In both of these courses, the participants all learned about the rules and proper manners when out on the water, how to use the craft correctly and safely, its particular performance characteristics, how to perform a pre-operation

check and more. While on the water, they were given training on how to steer the craft and experience its unique performance characteristics for themselves, verifying the amount of stopping distance needed, how to recover after capsizing, and more.

By continuing to hold courses and training like this, AJM Kooheji is confident they can strengthen their relationship with both customers and local authorities, and serve a central role in promoting the safe use and growth in demand for Yamaha WaveRunners in Bahrain.

From Hiroyuki Nagahisa, 1st Marketing Division, Marine Business Operations, YMC



News Round-up

Activities from distributors around the world, and more

2017 Miami International Boat Show Held

From February 16 to 20, 2017, the 76th Miami International Boat Show was held once again at Miami Marine Stadium Park & Basin on Virginia Key, offering both floating and indoor exhibit areas at the same venue. Several large exhibition tents were set up at the waterfront to create an indoor display area where a range of marine products were on display, from under-36 ft. class boats to marine engines and accessories. Also, the size of the outdoor display area was increased and a large number of boats and yachts could be seen docked out on the piers.

The event was blessed by good weather throughout its duration, bringing more visitors than last year; some 100,000 people from all over the world made the journey to this year's show.

Yamaha displayed its outboard motors,

WaveRunners and boats as well as propellers and rigging equipment, making a strong showing as a comprehensive marine manufacturer and supplier with a wide-ranging product lineup. Numerous new models were on display for show visitors, like the F25 and F90 in the outboard motor area, and the GPI800 and EX Deluxe WaveRunners and new 19 and 21-ft. jet-boats in the Sport Boat and WaveRunner area. With the large Yamaha banner hanging from the tent at the indoor venue, Yamaha Motor's presence at the show was indeed eye-catching.

From Yukiya Akahori, 1st Marketing Division, Marine Business Operations, YMC



First Edition of "Go Beyond Caravan" in Senegal

In December 2016, Yamaha distributor CFAO Motors Senegal and the teams of YMC's Overseas Market Development Operation Business Unit (OMDO) organized the first "Go Beyond Caravan" in the country. In 13 days, the caravan traveled the coast of Senegal from Saint-Louis to Djiffèr, covering the country's eight most important fishing areas.

With 718 km of open coastline, Senegal is reputed to have one of the richest fishing resources in the world. Fishing here plays an important role not only in the economy but also in feeding the population by providing nearly 70% of the protein in the national diet.

With over 23,000 ocean canoes, of which 95% are equipped with Yamaha outboards, Senegal boasts one of the largest fishing communities in the world. The Go Beyond Caravan was organized to give all fishermen and certified marine mechanics and dealers the benefit of OMDO expertise to improve the performance of their outboard motors, as well as safety at sea. The Caravan provides free outboard maintenance and heightens awareness of the benefits of Genuine Yamaha parts and the advantages of Yamalube oil. It was also an opportunity to offer special prices for Genuine Yamaha parts, something greatly appreciated by the hundreds of fishermen who had their outboards



inspected and diagnosed.

CFAO Motors and OMDO also took the opportunity to sensitize the population of the fishing villages to issue cleaning of beaches. It also helped to further strengthen the ties between Yamaha, CFAO Motors and the fishermen of Senegal. The Go Beyond Caravan will be an ongoing program supplementing service operations already being conducted by CFAO Motors throughout the year.

From Christian Razafinjato, CFAO Motors Senegal

Editor's Note



From this issue of *Chantey*, we welcome back our angling reporter, Kurt Takayanagi, for the first time in two years. This year he will again be contributing his informative and inspiring "fishing tales" enjoyed by so many of our readers until now, and he will be reporting this time from Australia where he has been newly positioned. We hope you will look forward to his contributions.

YAMAHA OUTBOARDS WEBSITE <https://global.yamaha-motor.com/business/outboards/index.html>

WAVERUNNER WEBSITE <https://global.yamaha-motor.com/business/waverunner/>

Yamaha Outboards Channel on YouTube

View waterside scenes and scenes of Yamaha outboards in use around the world

Yamaha Outboards Channel <https://www.youtube.com/user/Yamahaoutboardmotors>