



# PARTS CATALOGUE

## G31EXPS ( JB53 ) GUAM, MALAYSIA, PHILIPPINES

---



1TJB5-400E1



G31EXPS  
PARTS CATALOGUE  
©2017 by Yamaha Motor Co., Ltd.  
1st edition, December 2017  
All rights reserved.  
Any reprinting or unauthorized use  
without the written permission of  
Yamaha Motor Co., Ltd.  
is expressly prohibited.  
Printed in Japan.

# FOREWORD

This Parts Catalogue is related to the parts for the model(s) on the cover page. When you are ordering replacement parts, please refer to this Parts Catalogue and quote both part numbers and part names correctly.

1. Modifications or additions which have been made after the issue of the Parts Catalogue will be announced in the Parts News.  
It is advisable that you make the necessary corrections to the Parts Catalogue according to the Parts News.

2. Abbreviations

The following abbreviations are used in this Parts Catalogue.

“UR” Use specified parts number.

“UN” Use as many as needed.

“AP” Alternate Parts

“LM” Locally Made (Parts need to be ordered locally)

“F#” Frame No. (Applicable machine No.)

“O/S” Over Size

3. The number of components for assembly

- Parts, which are to be supplied in an assembly, are listed with a dot (.) in front of the part name as shown below.
- The numeral appearing to the right of each component part indicates the quantity of parts for each assembly unit.

PART NO.	DESCRIPTION	Q'TY	REMARKS
2F5-83310-60	FRONT FLASHER LIGHT ASSY	2	
115-83311-60	.BULB (6V-18W)	1	

4. Applicable colours of graphics are represented in the “REMARKS” as shown below.

PART NO.	DESCRIPTION	Q'TY	REMARKS
2N4-24110-00-X5	FUEL TANK COMP.	2	MXR
3J1-24240-10	.GRAPHIC, FUEL TANK	1	FOR MXR

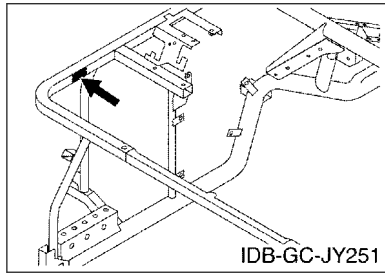
5. Note that the illustrations for reference in finding parts numbers are not to be used for assembling. When assembling, please use the applicable service manual.

6. The asterisk (\*) before a reference number indicates modified items after the first edition.

# FOREWORD

7. Applicable Serial No.

Frame Serial No.



8. Applicable Colour Code (The (\*) mark shows Model colour.)

Abbreviation	Colour Name	Colour Code
DNGM3(*)	DARK GRAYISH GREEN METALLIC 3	0712
DPBMC(*)	DEEP PURPLISH BLUE METALLIC C	0564
DRMD(*)	DULL RED METALLIC D	0779
RW(*)	RADICAL WHITE	00UJ

9. Quantity Column Information

Column No.	Name Of Q'ty Column	Destination
1	JB53	GUM, MYS, PHL

10. Applicable Starting Serial No.

Frame Serial No.

Serial No.	Name Of Q'ty Column	Model Code
JB5-0300101	JB53	JB53

# CONTENTS

## BODY

REAR ARM & SUSPENSION.....	1
FRAME.....	2
FRONT SUSPENSION & WHEEL.....	3
STEERING.....	5
BRAKE.....	7
BRAKE 2.....	8
BRAKE 3.....	10
BRAKE 4.....	12
FRONT MASTER CYLINDER.....	13
ACCELERATOR.....	15

## DRIVE

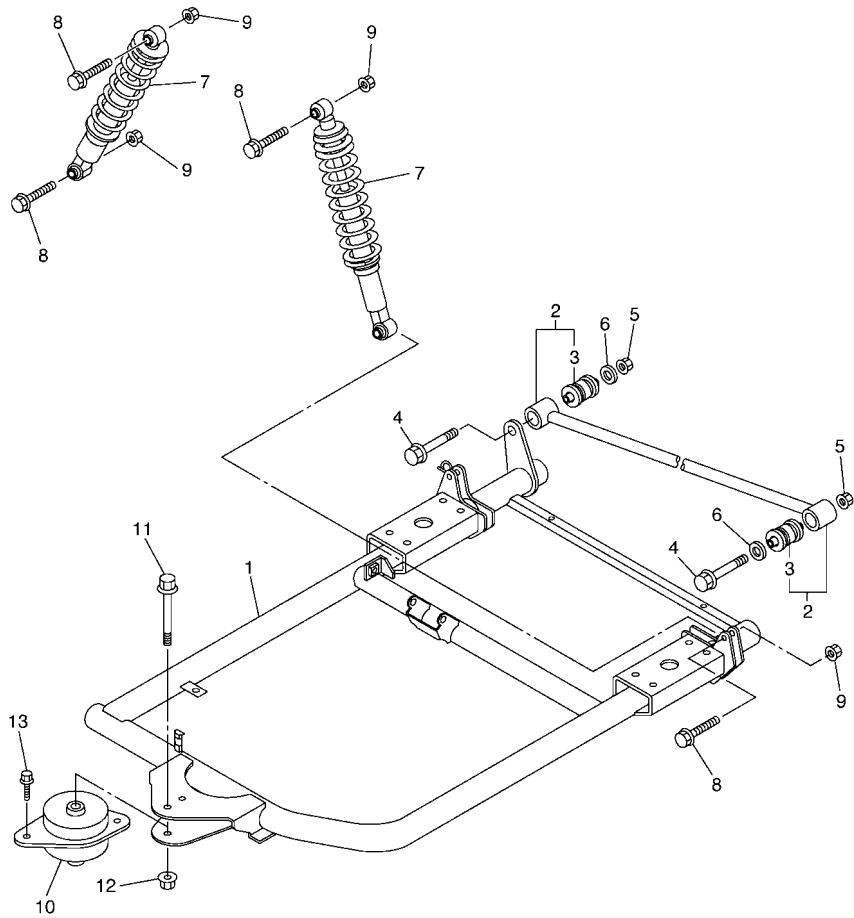
TRANSAXLE.....	16
REAR AXLE & WHEEL.....	18
WINDSHIELD(SPLIT TYPE).....	19
BUMPER.....	21
BODY.....	22
BODY 2.....	24
BODY FITTING.....	26
SUN ROOF.....	27
CARRIER(MOVABLE).....	29
SEAT.....	32

## ELECTRICAL

ELECTRIC MOTOR.....	34
CONTROL UNIT.....	35
ELECTRICAL 1.....	36

## INDEX

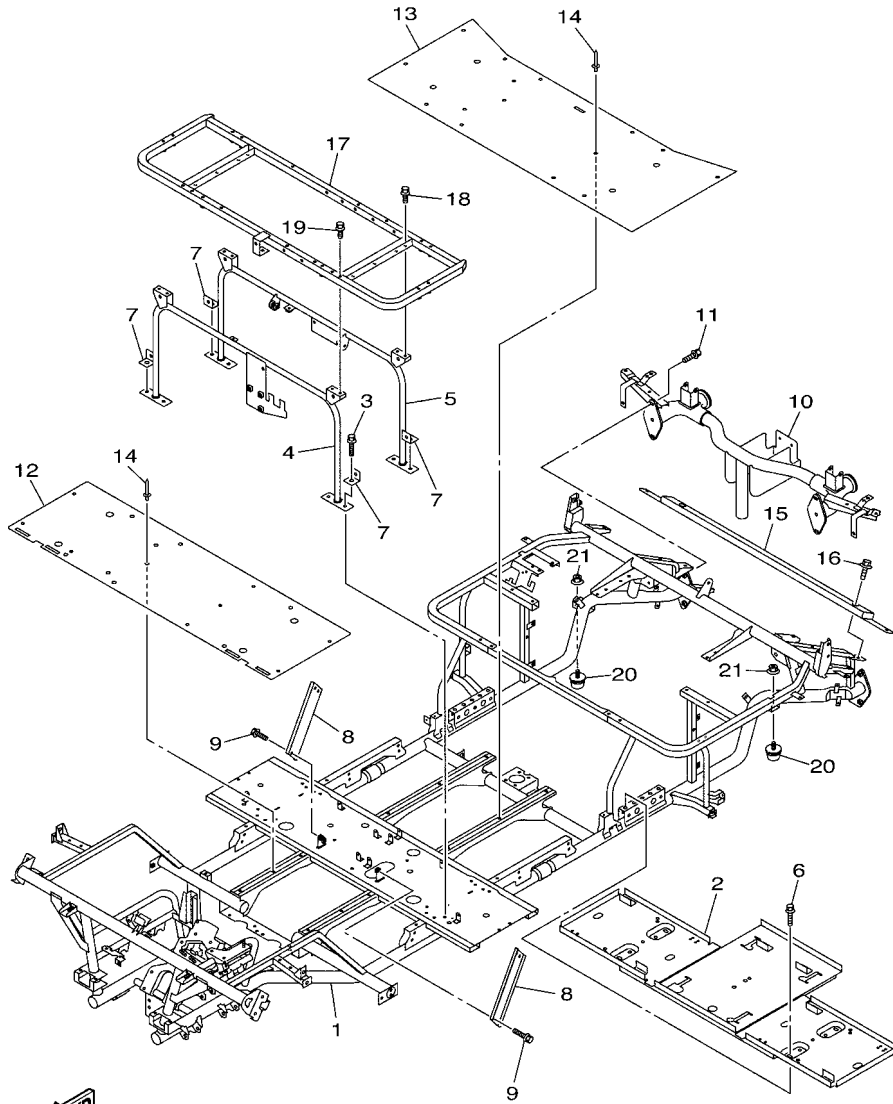
NUMERICAL INDEX.....	39
----------------------	----



JX31010-D010

**FIG. 1 REAR ARM & SUSPENSION**

REF. NO.	PART NO.	DESCRIPTION	JB53				REMARKS
1	JB8-22110-00	REAR ARM COMP.	1				
2	JB2-22172-00	ARM, REAR 2	1				
3	JX4-22124-00	.BUSH 2	2				
4	95812-12065	BOLT, FLANGE	2				
5	90185-12009	NUT, SELF-LOCKING	2				
6	90201-121J0	WASHER, PLATE	2				
7	JY3-22210-00	SHOCK ABSORBER ASSY, REAR	2				
8	95812-10045	BOLT, FLANGE	4				
9	95602-10200	NUT, S/L FLANGE	4				
10	JX4-22123-00	BUSH 1	1				
11	90105-12031	BOLT, FLANGE	1				
12	95602-12200	NUT, SELF-LOCKING	1				
13	95812-10016	BOLT, FLANGE	2				

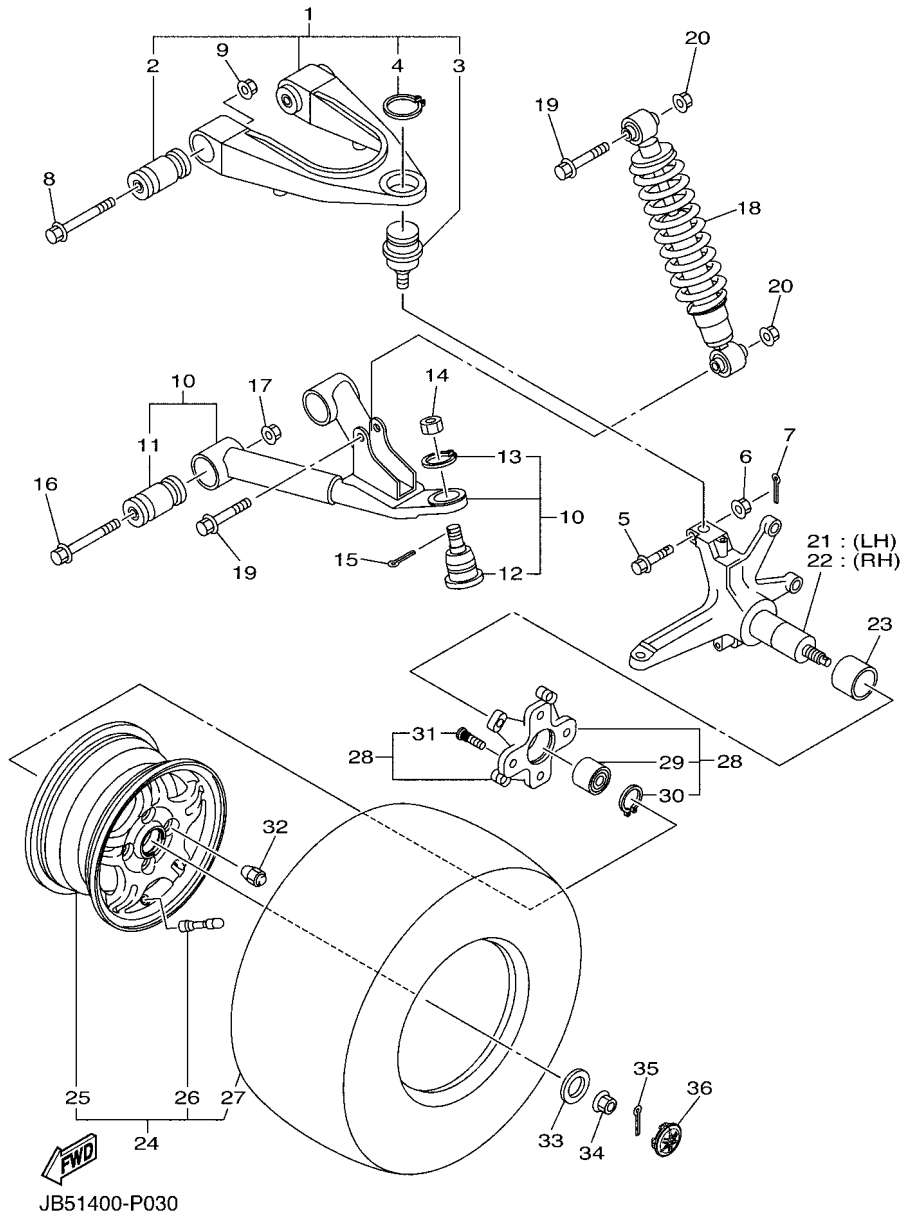


JB51400-P020

FIG. 2 FRAME

REF. NO.	PART NO.	DESCRIPTION	JB53				REMARKS
1	JB4-22501-09	FRAME COMP.	1				
2	JB8-22506-09	RR,CROSS MEMBER SUB ASSY	1				
3	95822-08016	BOLT, FLANGE	4				
4	JY8-2255A-00	PIPE ASSY	1				
5	JY8-2255A-10	PIPE ASSY	1				
6	95822-08016	BOLT, FLANGE	8				
7	JY8-22592-00	PLATE 1	4				
8	JY1-2259H-00	REINFORCEMENT 8	2				
9	95822-06016	BOLT, FLANGE	8				
10	JY6-22504-00	RR. SUB-FRAME COMP.	1				
11	95822-10025	BOLT, FLANGE	4				
12	JB2-22571-00	PANEL 1	1				
13	JY8-22572-10	PANEL 2	1				
14	90267-48101	RIVET, BLIND	20				
15	JX4-22597-00	REINFORCEMENT 2	1				
16	95812-08020	BOLT, FLANGE	2				
17	JB8-78460-00	SEAT FRAME COMP.	1				
18	95802-06012	BOLT, FLANGE	2				
19	95802-06030	BOLT, FLANGE	2				
20	5GJ-22426-00	BUMP, STOP	2				
21	95602-06200	NUT, SELF-LOCKING	2				

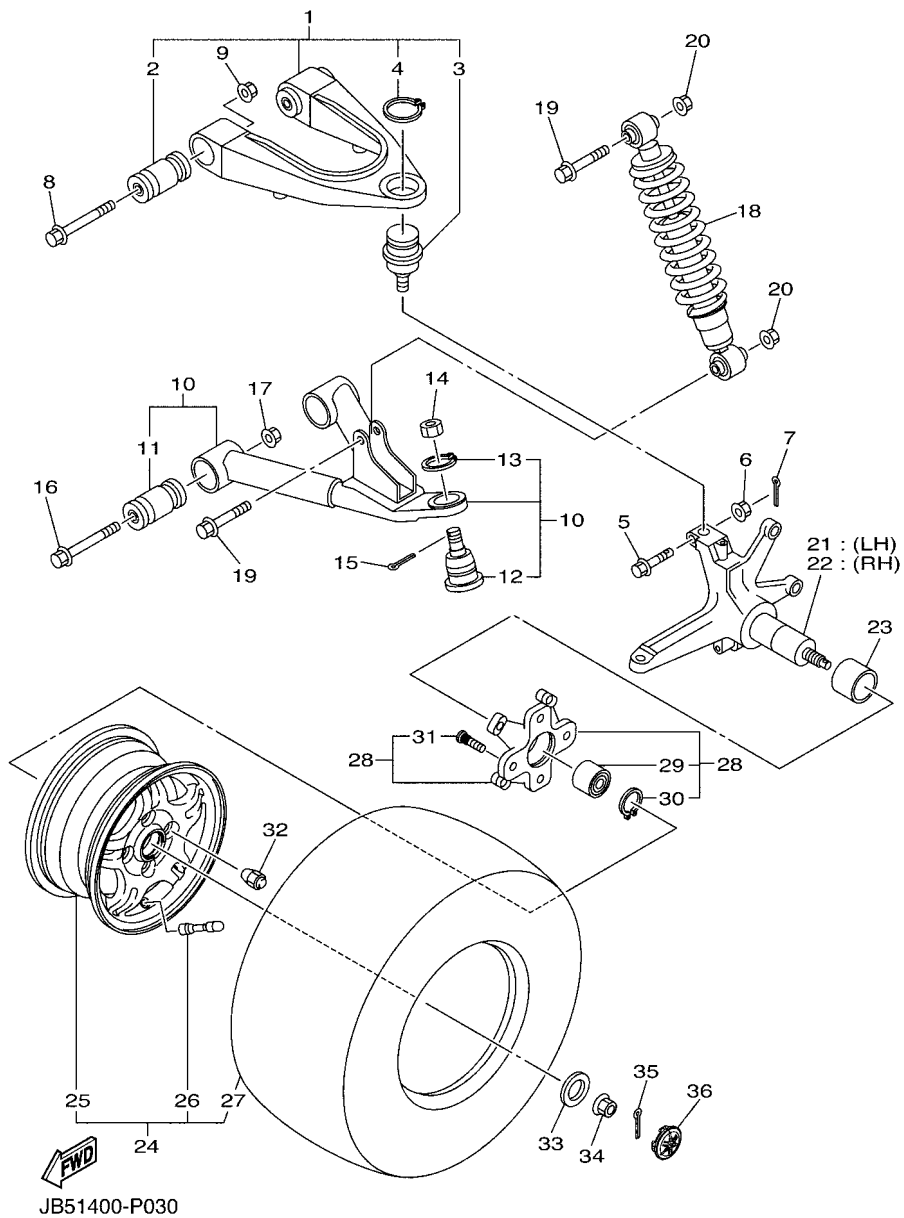
**FIG. 3 FRONT SUSPENSION & WHEEL**



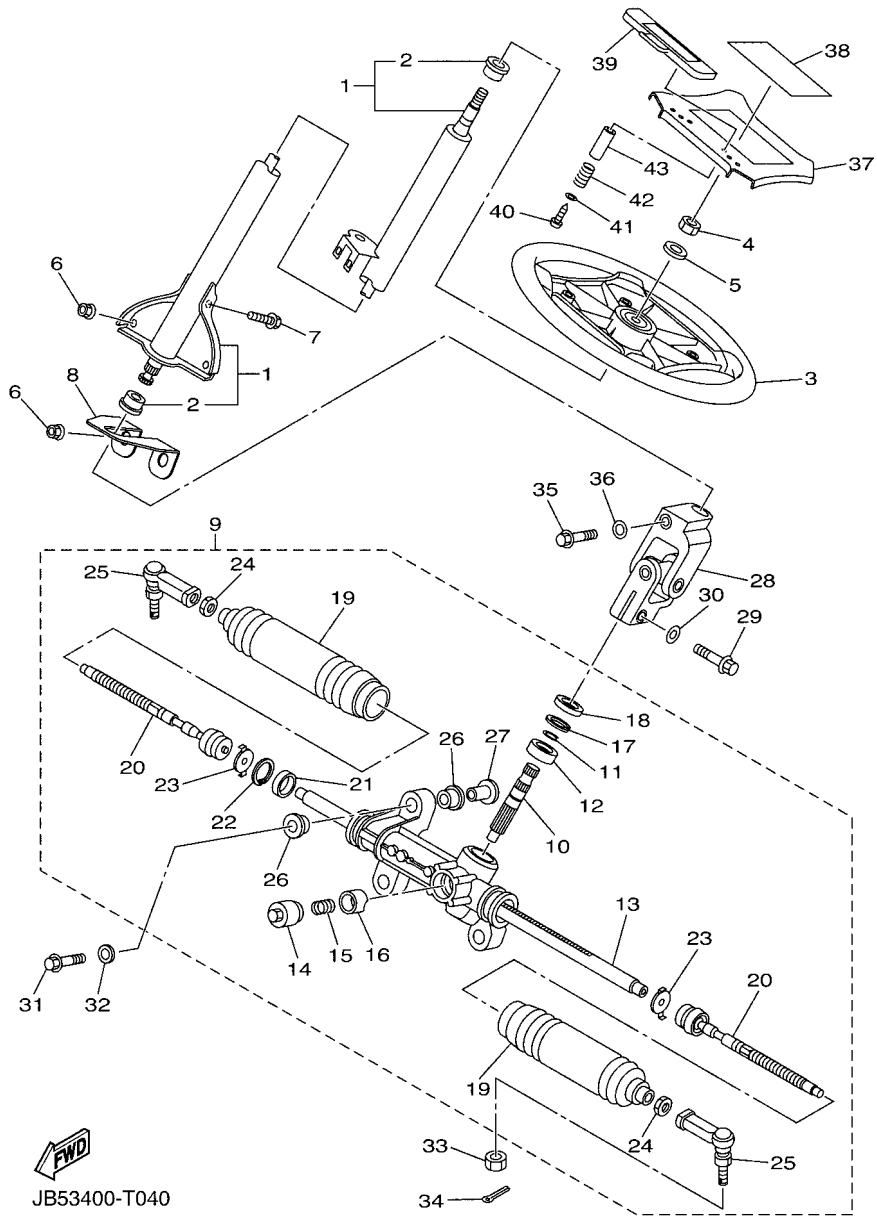
REF. NO.	PART NO.	DESCRIPTION	JB53	REMARKS
1	JB2-23540-00	FRONT UPPER ARM COMP. (LEFT)	2	
2	2HR-23526-00	.BUSH	2	
3	JX4-23549-01	.BALL JOINT 1	1	
4	99009-30400	.CIRCLIP	1	
5	90105-10728	BOLT, FLANGE	2	
6	95702-10500	NUT, FLANGE	2	
7	91402-25020	PIN, COTTER	2	
8	90105-10116	BOLT, FLANGE	4	
9	95607-10200	NUT, U FLANGE	4	
10	JY8-23570-01	FRONT LOWER ARM COMP.	2	
11	2HR-23526-00	.BUSH	2	
12	JX4-23579-01	.BALL JOINT 2	1	
13	99009-32400	.CIRCLIP	1	
14	90171-12001	NUT, CASTLE	2	
15	91402-25020	PIN, COTTER	2	
16	90105-10221	BOLT, FLANGE	4	
17	95602-10200	NUT, S/L FLANGE	4	
18	JY8-23350-01	SHOCK ABSORBER ASSY	2	
19	95822-10045	BOLT, FLANGE	4	
20	95602-10200	NUT, S/L FLANGE	4	
21	JX2-23510-00	KNUCKLE, STEERING COMP. (LEFT)	1	
22	JX2-23520-00	STEERING KNUCKLE COMP. (RIGHT)	1	
23	90387-30006	COLLAR	2	
24	JY8-25100-30	AL WHEEL ASSY (190/50-12 6PR)	2	
25	JY8-25180-00	.WHEEL COMP. (ALUMINIUM)	1	
26	93900-00022	.VALVE, RIM (TR413)	1	TAIHEIYO
27	JY8-2510S-20	.TIRE (190/50-12 6PR KENDA)	1	



**FIG. 3 FRONT SUSPENSION & WHEEL**



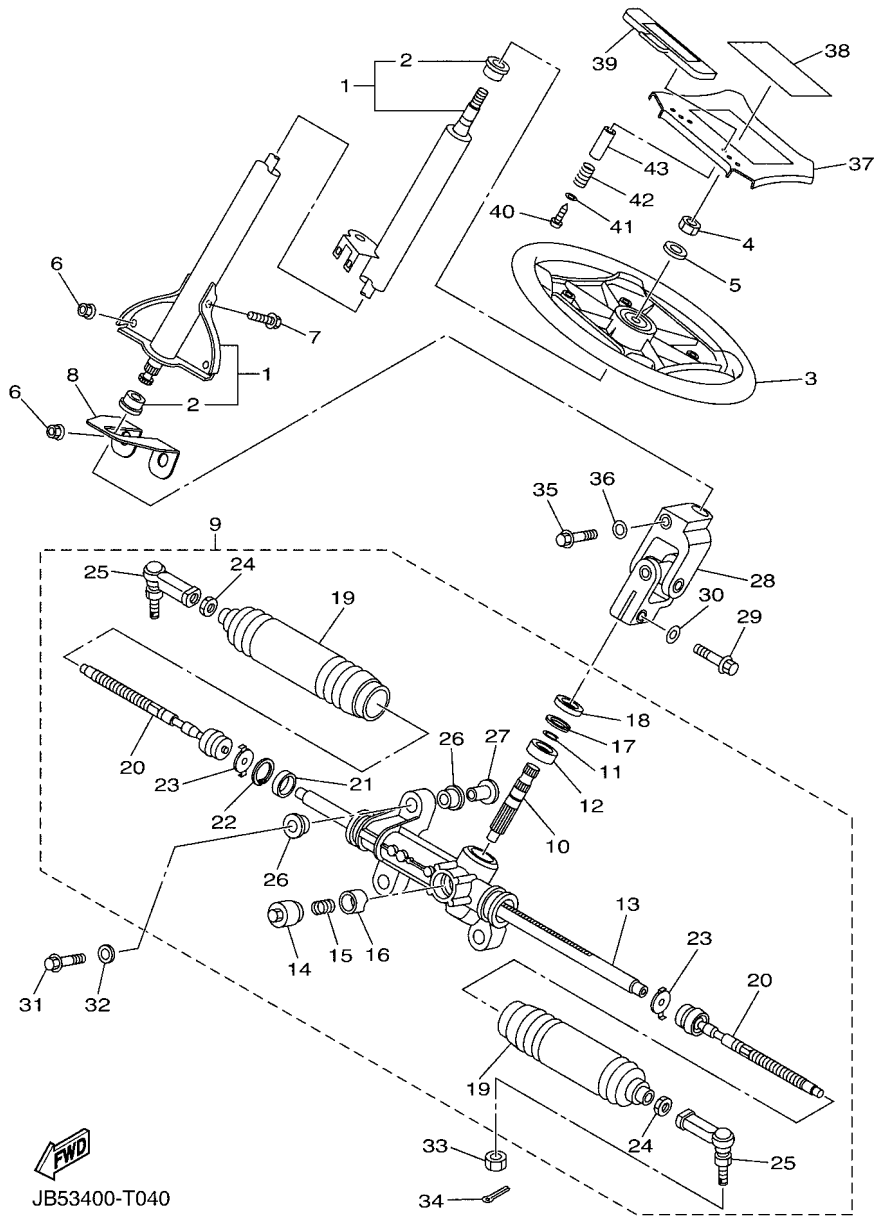
REF. NO.	PART NO.	DESCRIPTION	JB53				REMARKS
28	JY2-25110-00	HUB ASSY, FRONT	2				
29	93305-00602	.BEARING	1				
30	99009-55500	.CIRCLIP	1				
31	90114-10019	.BOLT, SERRATION	4				
32	90179-10031	NUT	8				
33	90201-163M0	WASHER, PLATE	2				
34	95604-16200	NUT, U FLANGE	2				
35	91402-25020	PIN, COTTER	2				
36	JY8-2512A-01	CAP, WHEEL	2				



JB53400-T040

FIG. 4 STEERING

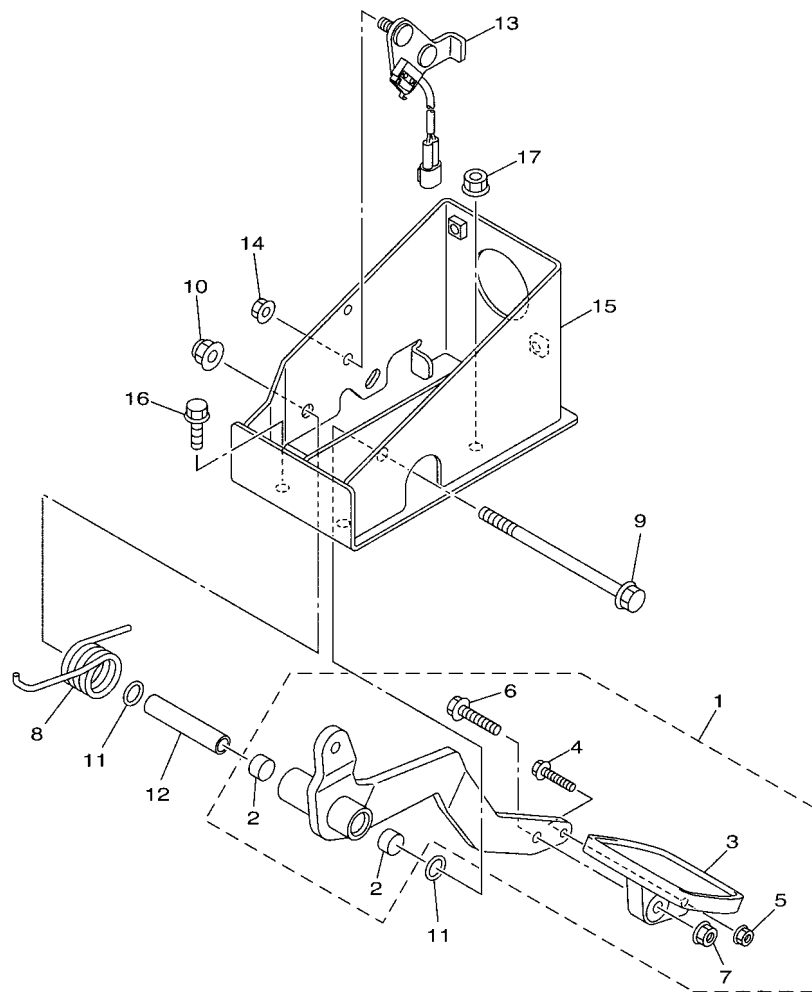
REF. NO.	PART NO.	DESCRIPTION	JB53				REMARKS
1	JY1-23810-10	STEERING COLUMN ASSY	1				
2	J50-23857-00	.HOLDER	2				
3	JN5-23838-00	WHEEL, STEERING	1				
4	95602-12100	NUT, U	1				
5	90201-12190	WASHER, PLATE	1				
6	95702-08500	NUT, FLANGE	4				
7	95812-08020	BOLT, FLANGE	1				
8	JB6-2386N-01	STOPPER	1				
9	JX4-23400-01	STEERING ASSY	1				
10	JX4-2387A-01	.GEAR,PINION	1				
11	JX4-2384N-00	.CLIP, RING	1				
12	JX4-23812-00	.BEARING, STEERING	1				
13	JX4-2387E-00	.GEAR, RACK	1				
14	JR7-2387G-00	.COVER, ADJUST	1				
15	JR7-2387K-00	.SPRING, PRESSURE	1				
16	JR7-2387F-00	.PAD, PRESSURE	1				
17	JR7-2387J-00	.RING, STOPPER	1				
18	JR7-23844-00	.SEAL	1				
19	JR7-23848-00	.BOOTS B	2				
20	JX4-23837-00	.ROD, TIE 2	2				
21	JR7-2467K-00	.BUSH CAP	1				
22	JR7-23866-00	.RING, SNAP	1				
23	JR7-23894-00	.WASHER, LOCK 1	2				
24	JR7-23833-00	.NUT 1	2				
25	JX4-23841-00	.JOINT, UNIVERSAL 1	2				
26	JX4-23445-00	.BUSH	6				
27	JX4-23417-00	.COLLAR	3				



**FIG. 4 STEERING**

REF. NO.	PART NO.	DESCRIPTION	JB53				REMARKS
28	JR9-23823-01	JOINT 2	1				
29	JX4-23876-00	BOLT	1				
30	JX4-23427-00	WASHER	1				
31	90105-10283	BOLT, FLANGE	3				
32	90201-105A2	WASHER, PLATE	3				
33	90171-12001	NUT, CASTLE	2				
34	91402-25020	PIN, COTTER	2				
35	JX4-23876-00	BOLT	1				
36	JX4-23427-00	WASHER	1				
37	JN5-78357-10	HOLDER 1	1				
38	JY6-77762-10	LABEL, WARNING 2	1				
39	JX4-78358-00	HOLDER 2	1				
40	97707-40525	SCREW, TAPPING	2				
41	90201-044H9	WASHER, PLATE	2				
42	90502-10013	SPRING, CONICAL	2				
43	90387-046N7	COLLAR	2				

**FIG. 5 BRAKE**



REF. NO.	PART NO.	DESCRIPTION	JB53				REMARKS
1	JB2-27200-00	PEDAL, BRAKE	1				
2	90384-14080	.BUSH, BIMETAL FORMED	2				
3	JB2-27211-00	.PEDAL, BRAKE	1				
4	95822-06030	.BOLT, FLANGE	1				
5	95702-06500	.NUT, FLANGE	1				
6	95802-08035	.BOLT, FLANGE	1				
7	95702-08500	.NUT, FLANGE	1				
8	90508-40015	SPRING, TORSION	1				
9	95812-10090	BOLT, FLANGE	1				
10	90185-10019	NUT, SELF-LOCKING	1				
11	93210-132A8	O-RING	2				
12	90387-10109	COLLAR	1				
13	JB2-82530-00	STOP SWITCH ASSY	1				
14	95702-08500	NUT, FLANGE	2				
15	JB2-27263-00	BRACKET 1	1				
16	95822-08014	BOLT, FLANGE	2				
17	95702-08500	NUT, FLANGE	1				



JB21010-P170

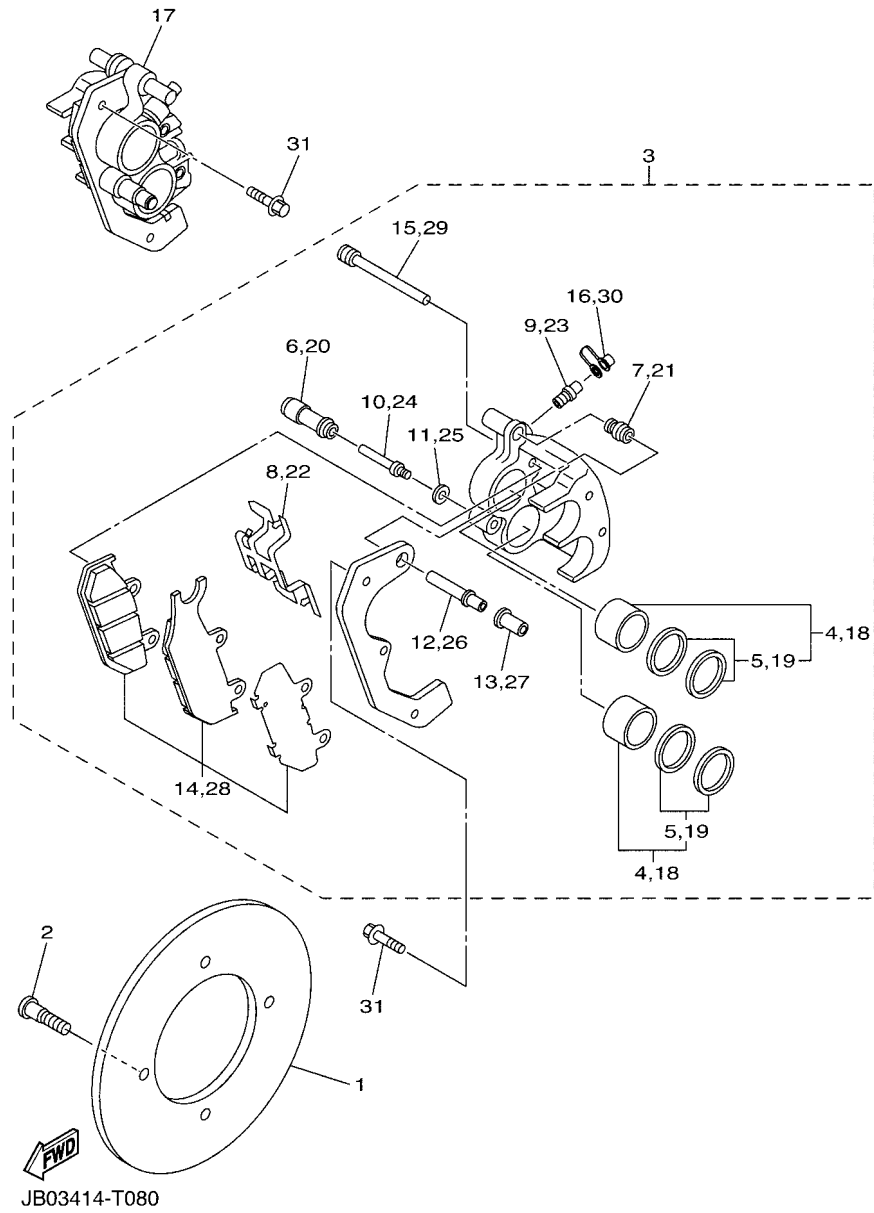


FIG. 6 BRAKE 2

REF. NO.	PART NO.	DESCRIPTION	QTY	REMARKS
1	JX2-2582T-00	DISC, BRAKE	2	
2	90109-08221	BOLT	8	
3	JX2-2580T-02	CALIPER ASSY (LEFT)	1	
4	3TB-W0057-00	.PISTON ASSY, CALIPER	2	
5	3GD-W0047-00	..CALIPER SEAL KIT	1	
6	1UY-25937-51	.BOOT 2	1	
7	3JD-25917-00	.BOOT, CALIPER	1	
8	JX2-25919-00	.SUPPORT, PAD	1	
9	1UY-25824-51	.SCREW, BLEED	1	
10	1UY-25926-51	.BOLT	1	
11	1UY-25938-51	.WASHER, SPRING	1	
12	3JD-25926-00	.BOLT	1	
13	JX2-25961-00	.NUT	1	
14	JX2-W0045-11	.BRAKE PAD KIT	1	
15	3TB-25933-00	.WASHER, PAD PIN	2	
16	1UY-25825-51	.CAP	1	
17	JX2-2580U-02	CALIPER ASSY (RIGHT)	1	
18	3TB-W0057-00	.PISTON ASSY, CALIPER	2	
19	3GD-W0047-00	..CALIPER SEAL KIT	1	
20	1UY-25937-51	.BOOT 2	1	
21	3JD-25917-00	.BOOT, CALIPER	1	
22	JX2-25919-00	.SUPPORT, PAD	1	
23	1UY-25824-51	.SCREW, BLEED	1	
24	1UY-25926-51	.BOLT	1	
25	1UY-25938-51	.WASHER, SPRING	1	
26	3JD-25926-00	.BOLT	1	
27	JX2-25961-00	.NUT	1	

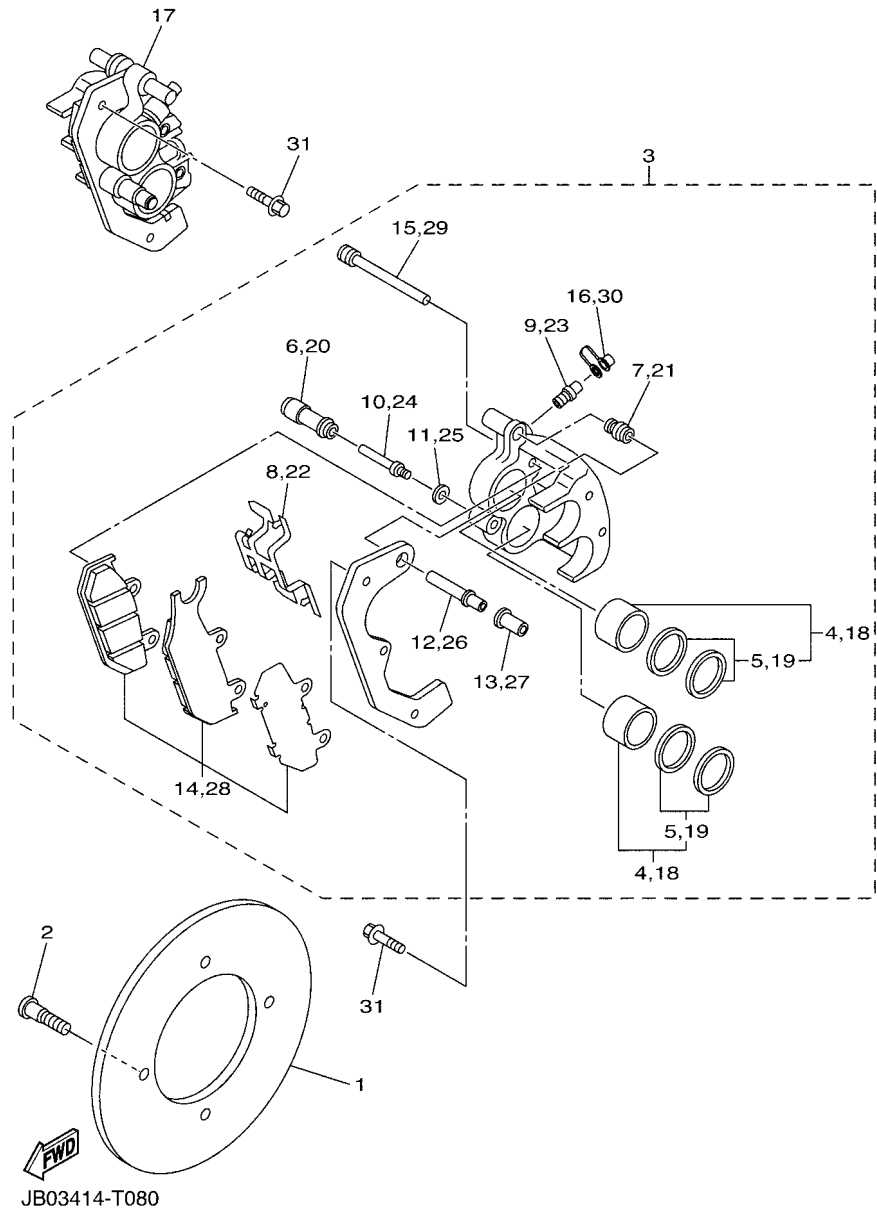
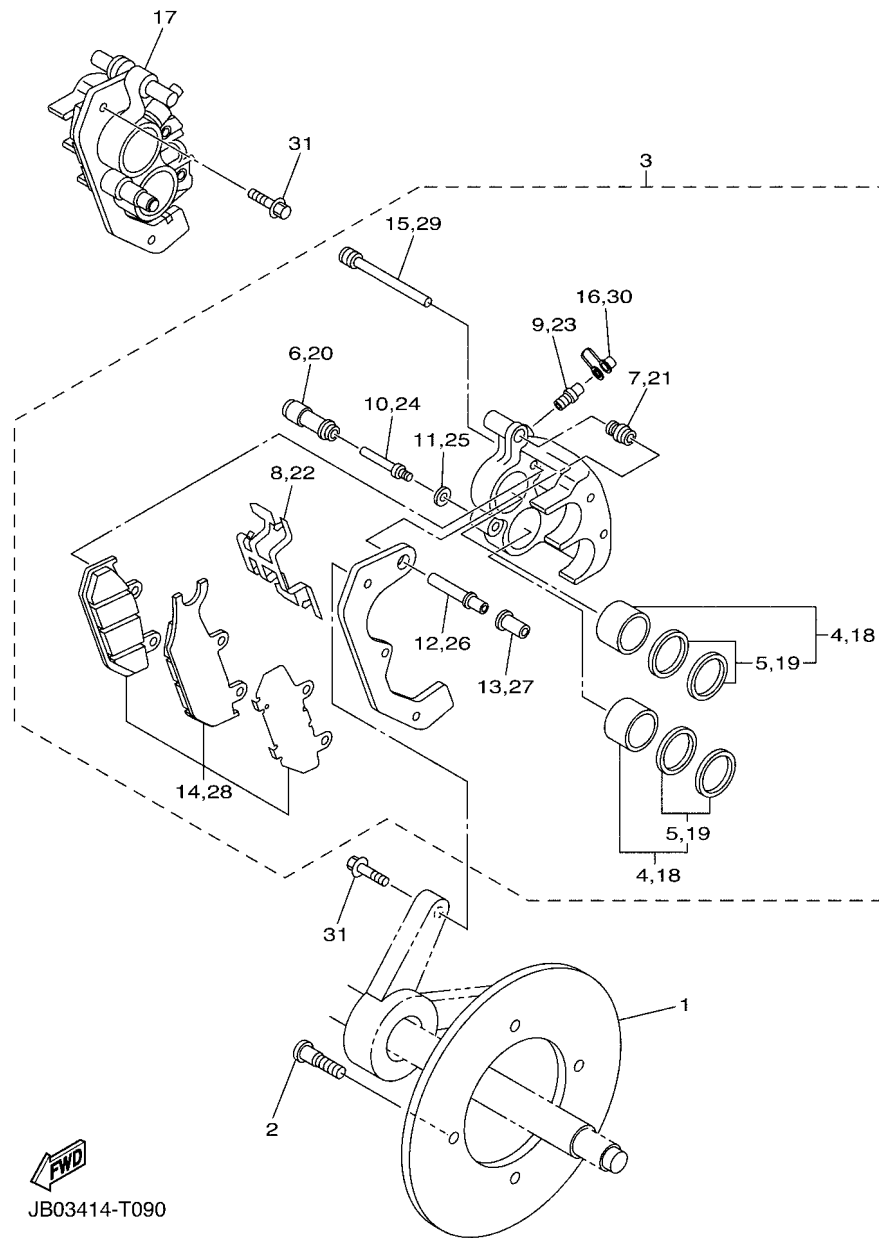


FIG. 6 BRAKE 2

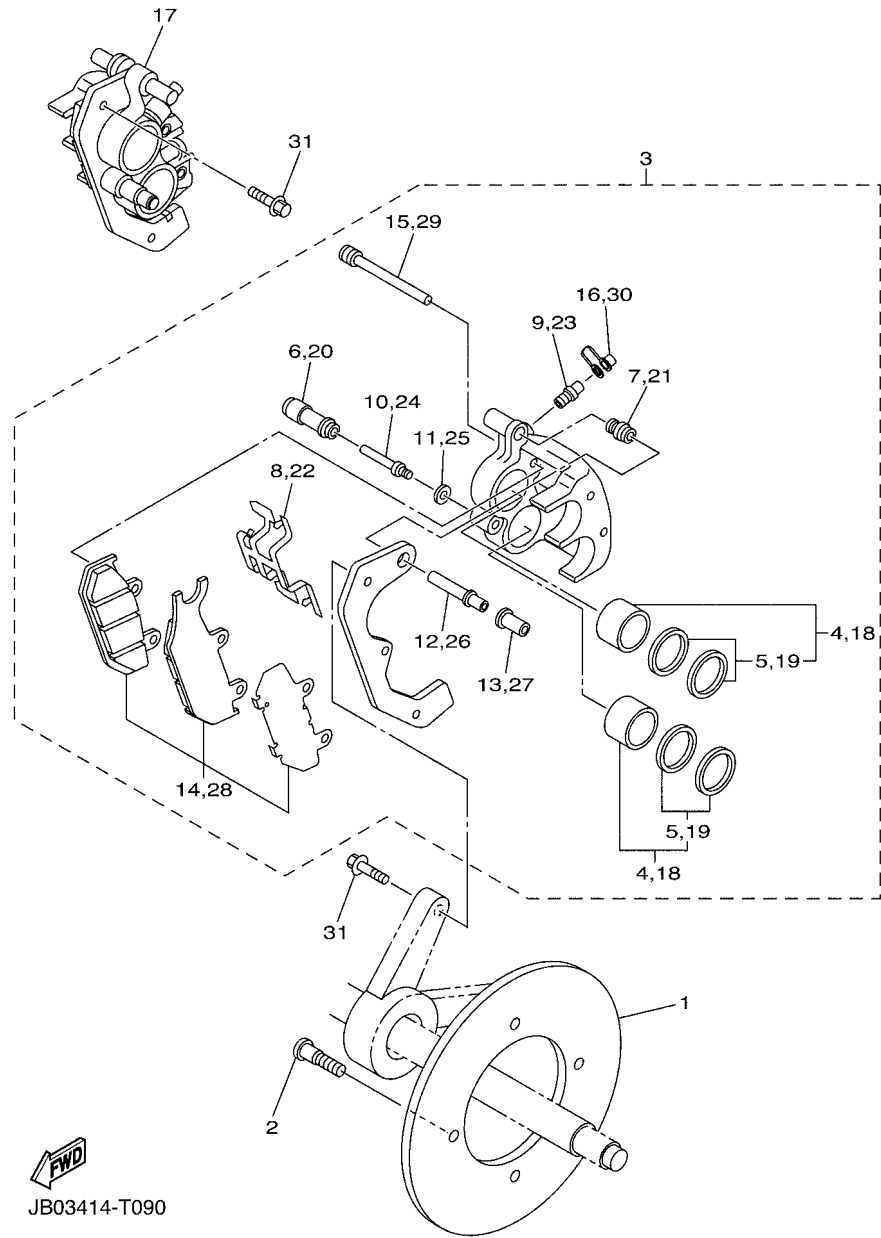
REF. NO.	PART NO.	DESCRIPTION	JB53				REMARKS
28	JX2-W0045-21	.BRAKE PAD KIT	1				
29	3TB-25933-00	.WASHER, PAD PIN	2				
30	1UY-25825-51	.CAP	1				
31	90105-102A9	BOLT, FLANGE	4				



**FIG. 7 BRAKE 3**

REF. NO.	PART NO.	DESCRIPTION	JBS3				REMARKS
1	JX2-2582T-00	DISC, BRAKE	2				
2	90109-08221	BOLT	8				
3	JX2-2580T-02	CALIPER ASSY (LEFT)	1				
4	3TB-W0057-00	.PISTON ASSY, CALIPER	2				
5	3GD-W0047-00	..CALIPER SEAL KIT	1				
6	1UY-25937-51	.BOOT 2	1				
7	3JD-25917-00	.BOOT, CALIPER	1				
8	JX2-25919-00	.SUPPORT, PAD	1				
9	1UY-25824-51	.SCREW, BLEED	1				
10	1UY-25926-51	.BOLT	1				
11	1UY-25938-51	.WASHER, SPRING	1				
12	3JD-25926-00	.BOLT	1				
13	JX2-25961-00	.NUT	1				
14	JX2-W0045-11	.BRAKE PAD KIT	1				
15	3TB-25933-00	.WASHER, PAD PIN	2				
16	1UY-25825-51	.CAP	1				
17	JX2-2580U-02	CALIPER ASSY (RIGHT)	1				
18	3TB-W0057-00	.PISTON ASSY, CALIPER	2				
19	3GD-W0047-00	..CALIPER SEAL KIT	1				
20	1UY-25937-51	.BOOT 2	1				
21	3JD-25917-00	.BOOT, CALIPER	1				
22	JX2-25919-00	.SUPPORT, PAD	1				
23	1UY-25824-51	.SCREW, BLEED	1				
24	1UY-25926-51	.BOLT	1				
25	1UY-25938-51	.WASHER, SPRING	1				
26	3JD-25926-00	.BOLT	1				
27	JX2-25961-00	.NUT	1				

**FIG. 7 BRAKE 3**

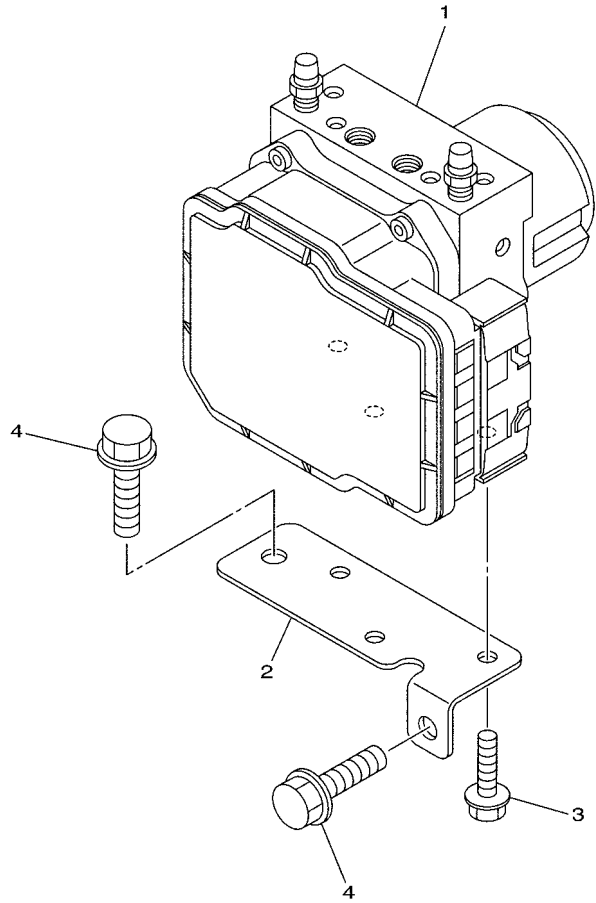


JB03414-T090

REF. NO.	PART NO.	DESCRIPTION	JB53			REMARKS
28	JX2-W0045-21	.BRAKE PAD KIT	1			
29	3TB-25933-00	.WASHER, PAD PIN	2			
30	1UY-25825-51	.CAP	1			
31	90105-102A9	BOLT, FLANGE	4			
<hr/>						
<hr/>						
<hr/>						
<hr/>						
<hr/>						
<hr/>						
<hr/>						
<hr/>						
<hr/>						
<hr/>						



**FIG. 8 BRAKE 4**

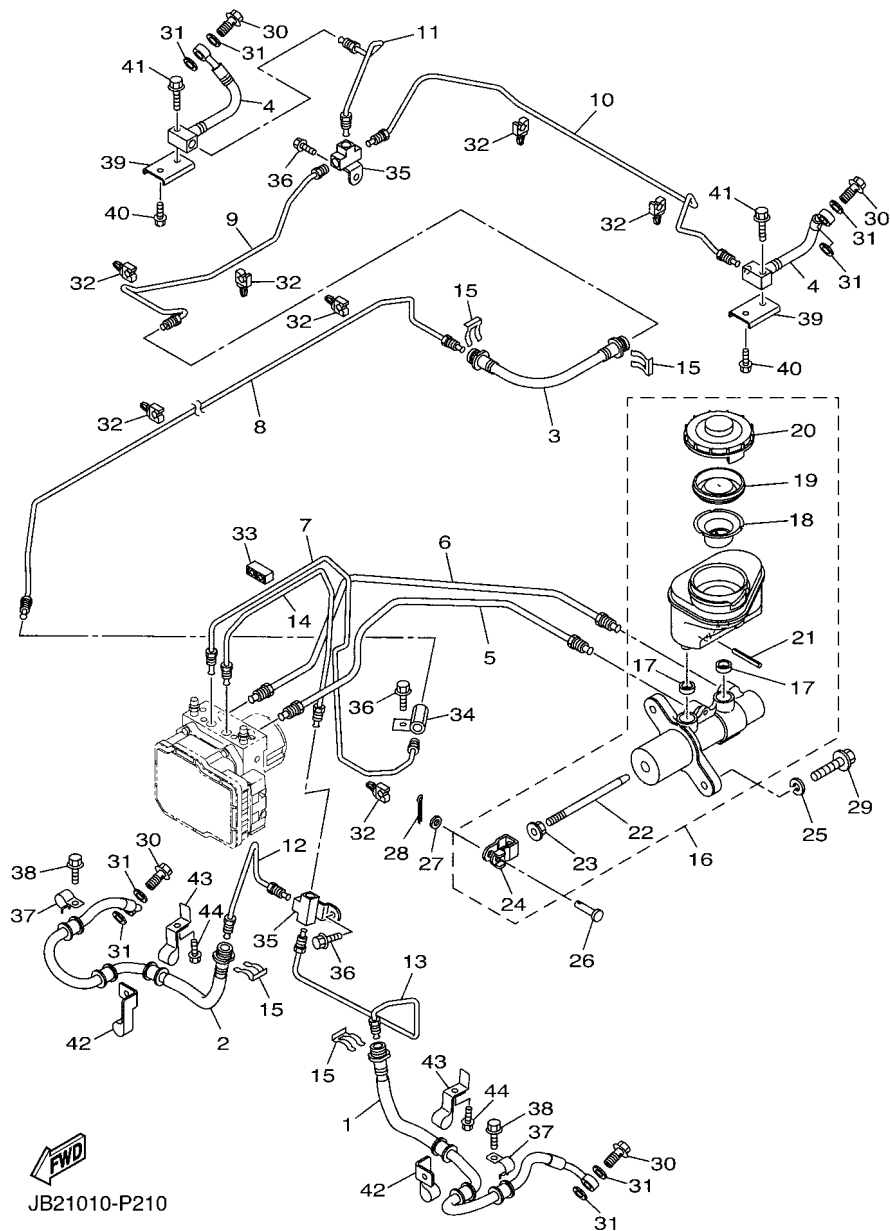


REF. NO.	PART NO.	DESCRIPTION	JB53				REMARKS
1	JB2-85930-09	HYDRAULIC UNIT ASSY	1				
2	JB2-27275-00	PLATE	1				
3	95812-06010	BOLT, FLANGE	3				
4	95812-08012	BOLT, FLANGE	2				
-----							
-----							
-----							
-----							
-----							
-----							
-----							
-----							
-----							
-----							



JB21010-P200

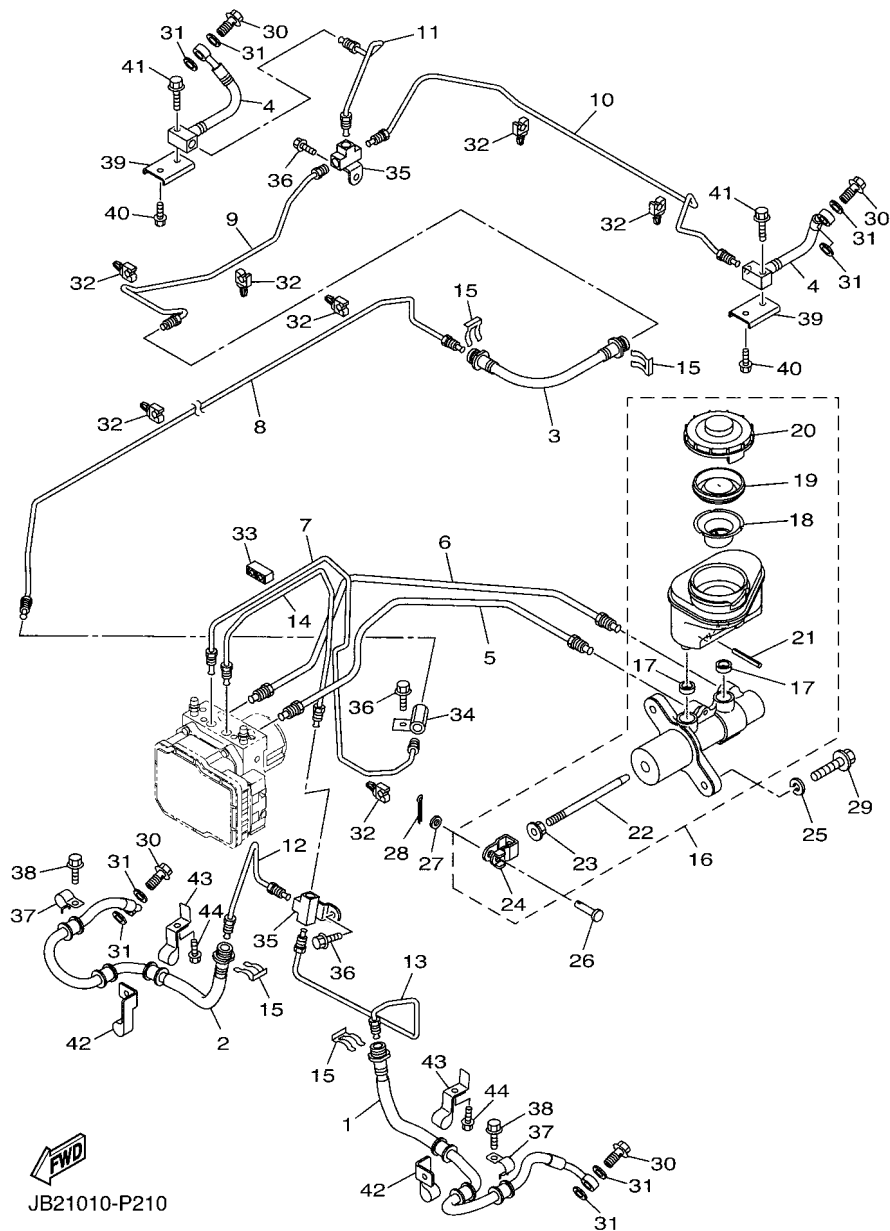
**FIG. 9 FRONT MASTER CYLINDER**



JB21010-P210

REF. NO.	PART NO.	DESCRIPTION	JB53				REMARKS
1	JB2-25872-00	HOSE, BRAKE 1	1				
2	JB2-25873-00	HOSE, BRAKE 2	1				
3	JB2-25874-00	HOSE, BRAKE	1				
4	JB2-2581J-00	HOSE, BRAKE 4	2				
5	JB2-2588H-00	PIPE, BRAKE 9	1				
6	JB2-2588J-00	PIPE, BRAKE 10	1				
7	JB2-25871-00	PIPE, BRAKE	1				
8	JX2-25882-10	PIPE, BRAKE 2	1				
9	JX3-25883-10	PIPE, BRAKE 3	1				
10	JB2-2588A-00	PIPE, BRAKE 4	1				
11	JB2-2588B-00	PIPE, BRAKE 5	1				
12	JX2-2588C-10	PIPE, BRAKE 6	1				
13	JY2-2588D-00	PIPE, BRAKE 7	1				
14	JB2-2588E-00	PIPE, BRAKE 8	1				
15	2GU-25866-00	CIRCLIP	4				
16	JB2-2583T-00	MASTER CYLINDER ASSY	1				
17	JB2-26326-00	.GROMMET	2				
18	JB2-25896-00	.PLATE, RESERVOIR	1				
19	JB2-25816-00	.SEAL, DUST	1				
20	JB2-25852-00	.CAP, RESERVOIR	1				
21	JB2-25826-00	.BOLT 3	1				
22	JB2-25880-00	.PUSH ROD COMP.	1				
23	JB2-27218-00	.NUT	1				
24	JB2-27222-00	.JOINT	1				
25	92902-08100	WASHER, SPRING	2				
26	JB2-27229-00	PIN, JOINT	1				
27	90201-08088	WASHER, PLATE	1				

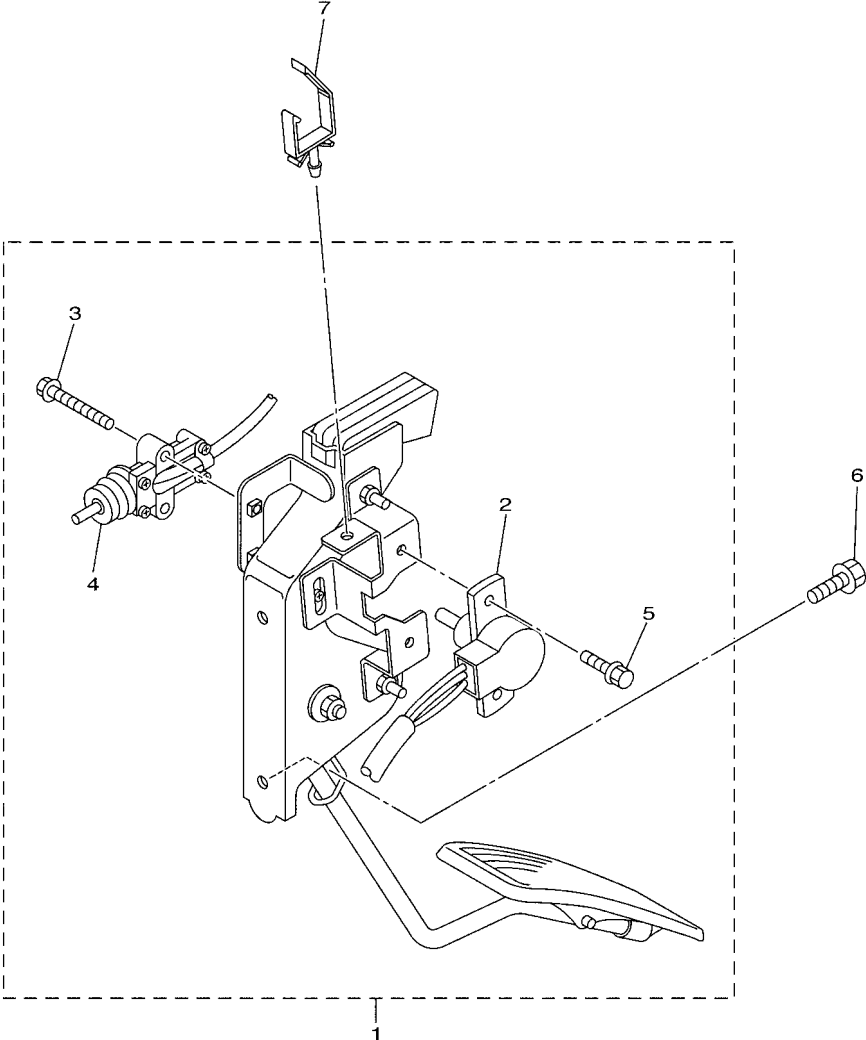
**FIG. 9 FRONT MASTER CYLINDER**



JB21010-P210

REF. NO.	PART NO.	DESCRIPTION	JB53				REMARKS
28	91490-25020	PIN. COTTER	1				
29	95812-08025	BOLT, FLANGE	2				
30	90401-10015	BOLT, UNION	4				
31	90201-10118	WASHER, PLATE	8				
32	5GM-81677-00	CLAMP 1	6				
33	90464-04002	CLAMP	2				
34	JX2-25885-11	JOINT	1				
35	JX2-2582A-00	JOINT	2				
36	95022-06012	BOLT, FLANGE	3				
37	5KM-25875-00	HOLDER, BRAKE HOSE 1	2				
38	95802-06012	BOLT, FLANGE	2				
39	JB2-25876-00	HOLDER, BRAKE HOSE 2	2				
40	95802-06012	BOLT, FLANGE	2				
41	95802-06025	BOLT, FLANGE	2				
42	JX2-25887-00	HOLDER, BRAKE HOSE	2				
43	JX2-2587A-00	HOLDER, BRAKE HOSE	2				
44	90109-06302	BOLT	2				

**FIG. 10 ACCELERATOR**



REF. NO.	PART NO.	DESCRIPTION	JB53	REMARKS
1	JY2-27801-01	ACCEL PEDAL ASSY	1	
2	JN9-85885-00	.THROTTLE SENSORASSY	1	
3	90105-05331	.BOLT, FLANGE	2	
4	JF7-82817-22	.SWITCH	1	
5	97507-05512	.BOLT, WITH WASHER	2	
6	95802-06012	BOLT, FLANGE	2	
7	90464-16021	CLAMP	1	



JB21010-P220

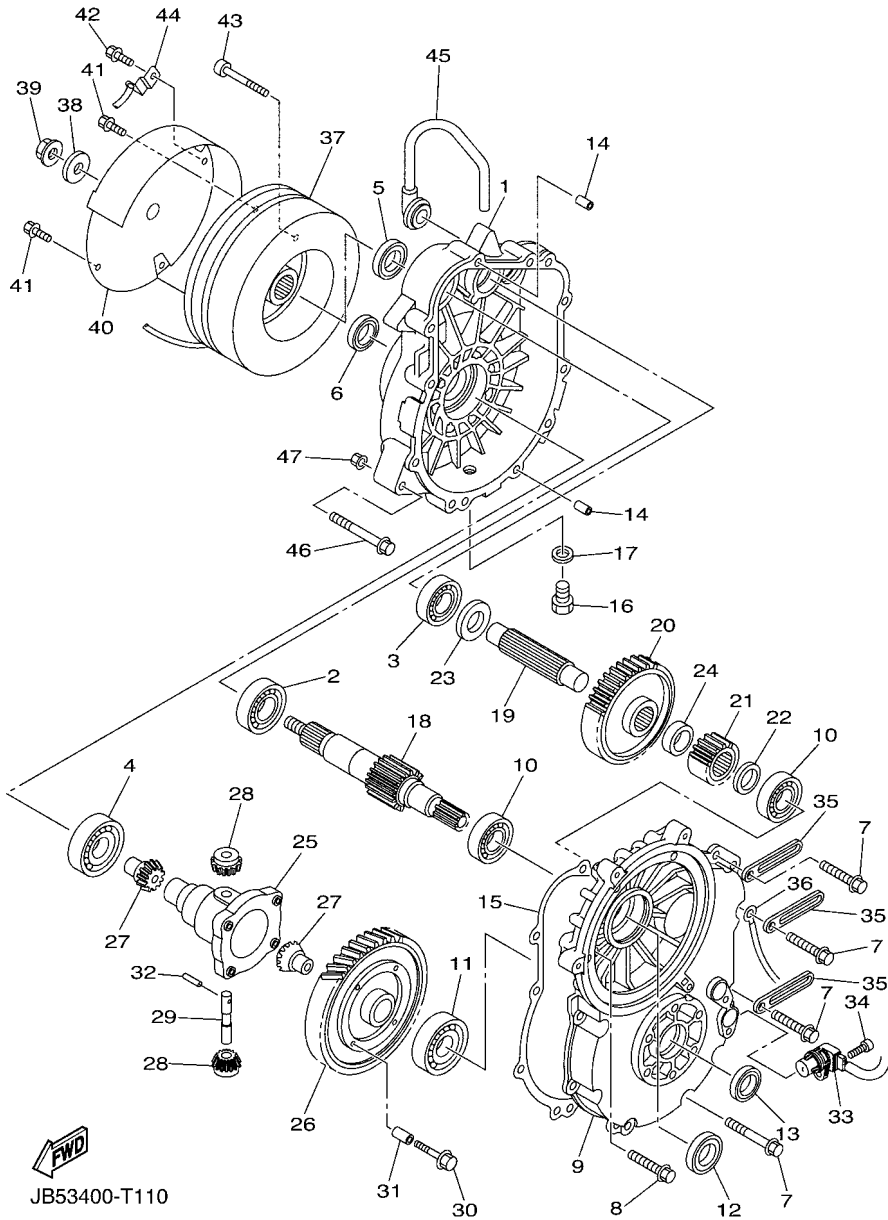
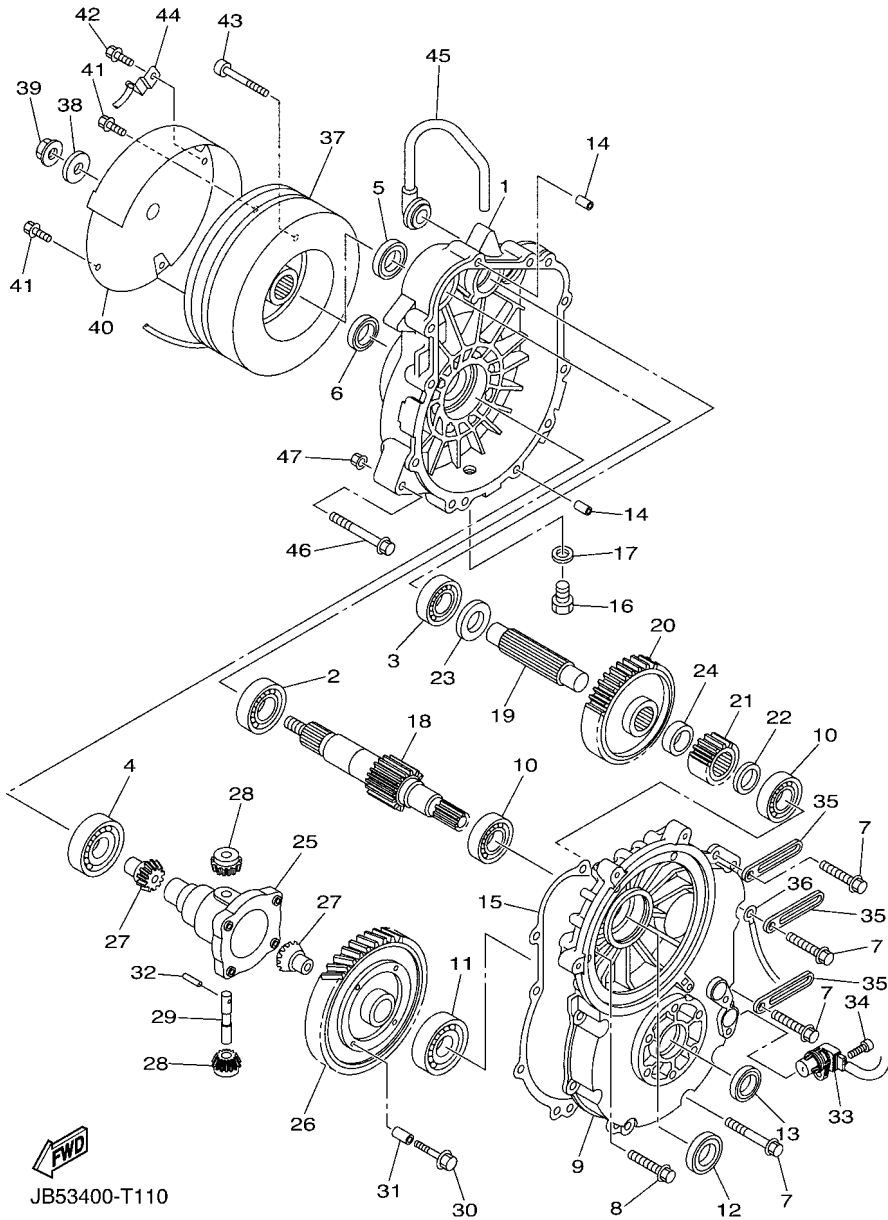


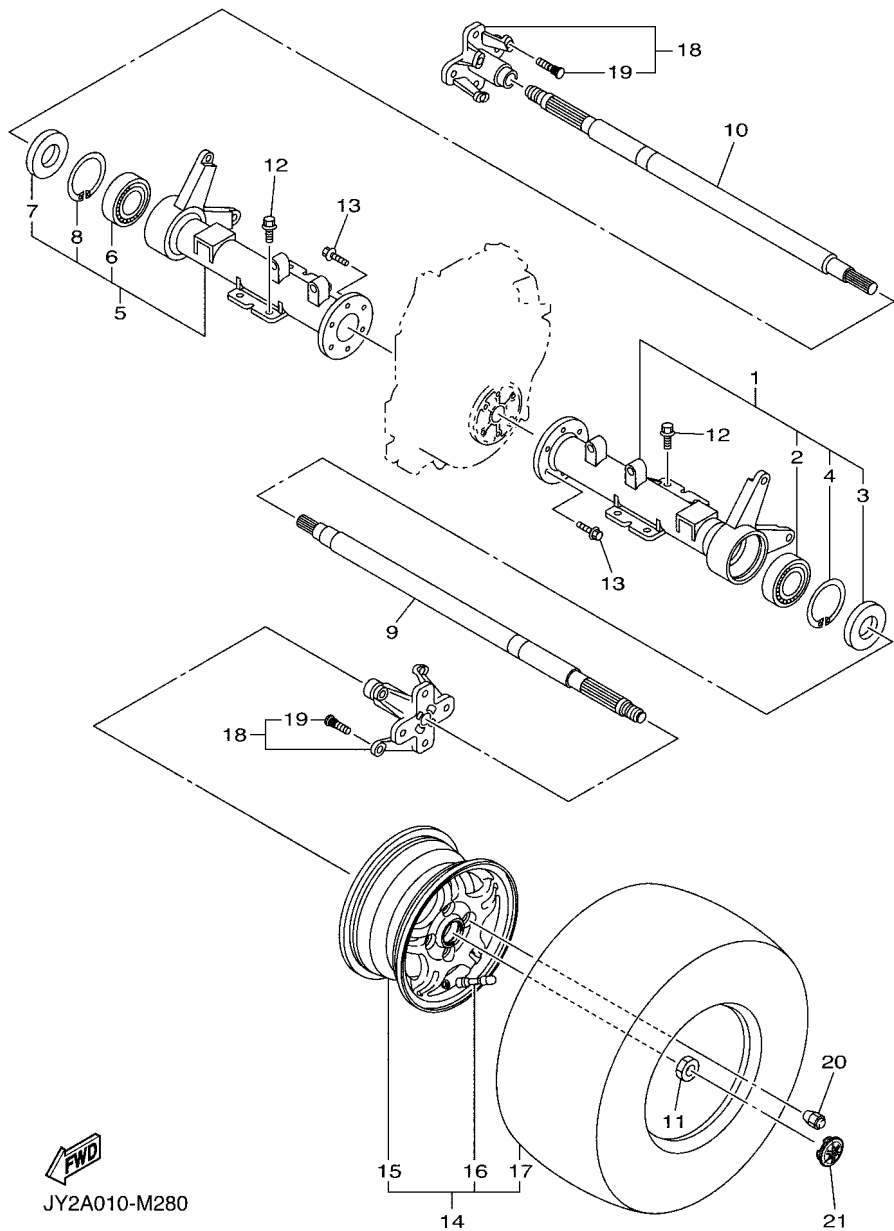
FIG. 11 TRANSAXLE

REF. NO.	PART NO.	DESCRIPTION	JB53				REMARKS
1	JB8-46311-00	CASE, TRANSMISSION 1	1				
2	93306-20501	BEARING	1				
3	93306-20401	BEARING	1				
4	93306-00803	BEARING	1				
5	93102-25017	OIL SEAL	1				
6	93102-25360	OIL SEAL	1				
7	95822-08040	BOLT, FLANGE	8				
8	95822-08050	BOLT, FLANGE	2				
9	JB8-46312-00	CASE, TRANSMISSION 2	1				
10	93306-20401	BEARING	2				
11	93306-00803	BEARING	1				
12	93102-20143	OIL SEAL	1				
13	93102-25360	OIL SEAL	1				
14	99530-12016	PIN, DOWEL	2				
15	JX3-46319-00	GASKET	1				
16	90340-14036	PLUG, STRAIGHT SCREW	1				
17	90430-14043	GASKET	1				
18	JB3-46321-00	SHAFT, INPUT	1				
19	JB3-46351-00	SHAFT, COUNTER	1				
20	JB3-46361-00	GEAR, COUNTER 1	1				
21	JB3-46362-00	GEAR, COUNTER 2	1				
22	90201-20032	WASHER, PLATE	1				
23	90201-20033	WASHER, PLATE	1				
24	90387-252M8	COLLAR	1				
25	JB2-46411-00	CASE, DIFFERENTIAL	1				
26	JB3-46421-00	GEAR, RING	1				
27	JB2-46414-00	GEAR, DIFFERENTIAL SIDE	2				

**FIG. 11 TRANSAXLE**



REF. NO.	PART NO.	DESCRIPTION	JB53				REMARKS
28	JB2-46415-00	PINION, DIFFERENTIAL	2				
29	JB2-46417-00	PIN, DIFFERENTIAL	1				
30	90105-10348	BOLT, FLANGE	4				
31	99530-14016	PIN, DOWEL	2				
32	91609-40040	PIN, SPRING	1				
33	JB2-86281-00	SENSOR, SPEED	1				
34	90110-06091	BOLT, HEXAGON SOCKET HEAD	1				
35	90462-08007	CLAMP	3				
36	JY3-82519-00	WIRE, EARTH LEAD	1				
37	JX3-86290-00	ELECTRO MAGNETIC BRAKE ASSY	1				
38	90201-12195	WASHER, PLATE	1				
39	95602-12200	NUT, SELF-LOCKING	1				
40	JX2-8234W-01	COVER, CAP	1				
41	95802-06010	BOLT, FLANGE	2				
42	90105-06452	BOLT, FLANGE	1				
43	91317-08045	BOLT,HEX.SOCKET HEAD	3				
44	JY3-83688-00	SENSOR ASSY	1				
45	JN3-47559-00	CAP 2	1				
46	95812-08075	BOLT, FLANGE	1				
47	90179-08491	NUT	1				

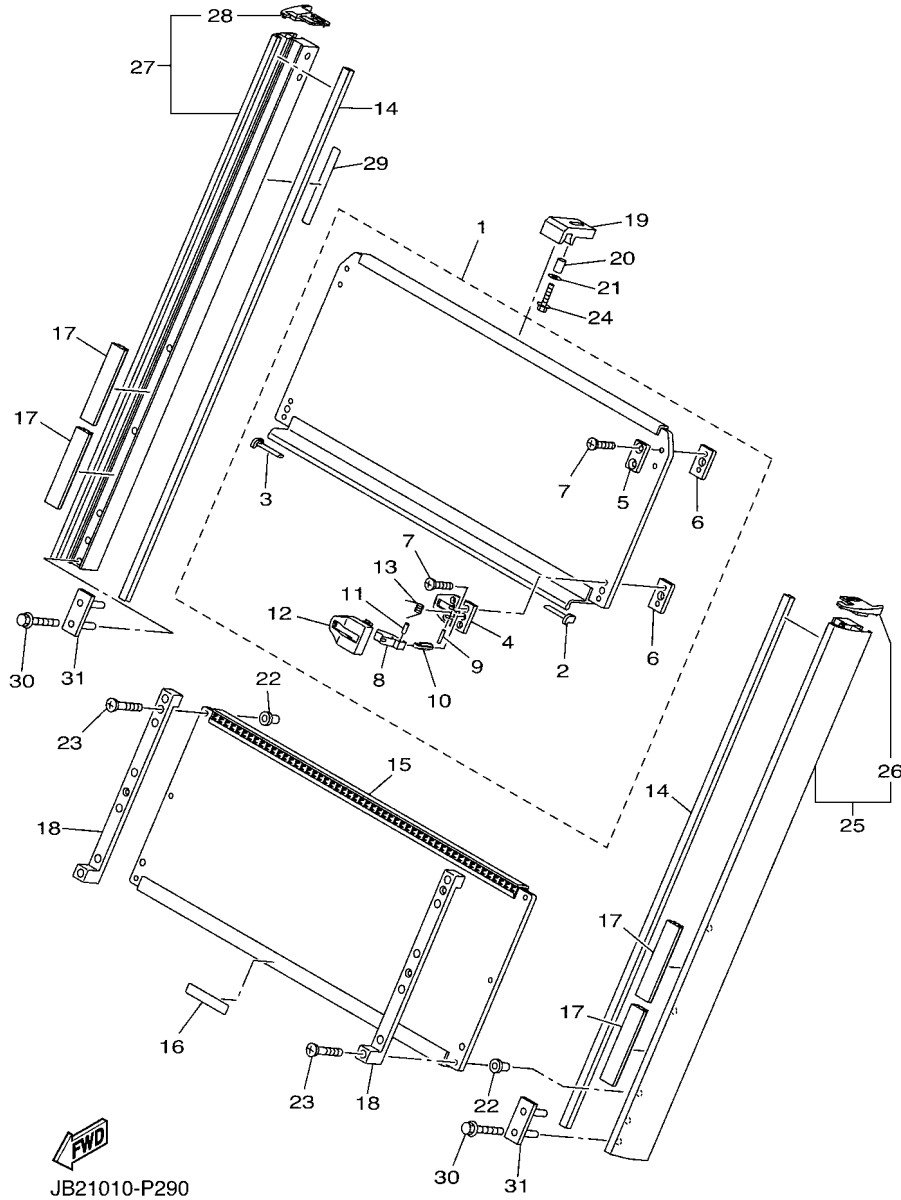


JY2A010-M280

FIG. 12 REAR AXLE & WHEEL

REF. NO.	PART NO.	DESCRIPTION	JBS3				REMARKS
1	JX2-46540-00	REAR AXLE HOUSING COMP.	1				
2	93306-30578	.BEARING	1				
3	93102-35109	.OIL SEAL (SD-35-62-6 HS)	1				
4	99009-62500	.CIRCLIP	1				
5	JX2-46550-00	REAR AXLE HOUSING COMP. 2	1				
6	93306-30578	.BEARING	1				
7	93102-35109	.OIL SEAL (SD-35-62-6 HS)	1				
8	99009-62500	.CIRCLIP	1				
9	JY2-46511-00	SHAFT, REAR AXLE 1 (L.H)	1				
10	JY2-46512-00	SHAFT, REAR AXLE 2 (R.H)	1				
11	90179-20016	NUT	2				
12	90101-10038	BOLT	8				
13	95812-10030	BOLT, FLANGE	12				
14	JY8-25100-30	AL WHEEL ASSY (190/50-12 6PR)	2				
15	JY8-25180-00	.WHEEL COMP. (ALUMINIUM)	1				
16	93900-00022	.VALVE, RIM (TR413)	1				TAIHEIYO
17	JY8-2510S-20	.TIRE (190/50-12 6PR KENDA)	1				
18	JB2-25310-00	HUB ASSY	2				
19	90114-10019	.BOLT, SERRATION	4				
20	90179-10031	NUT	8				
21	JY8-2512A-01	CAP, WHEEL	2				

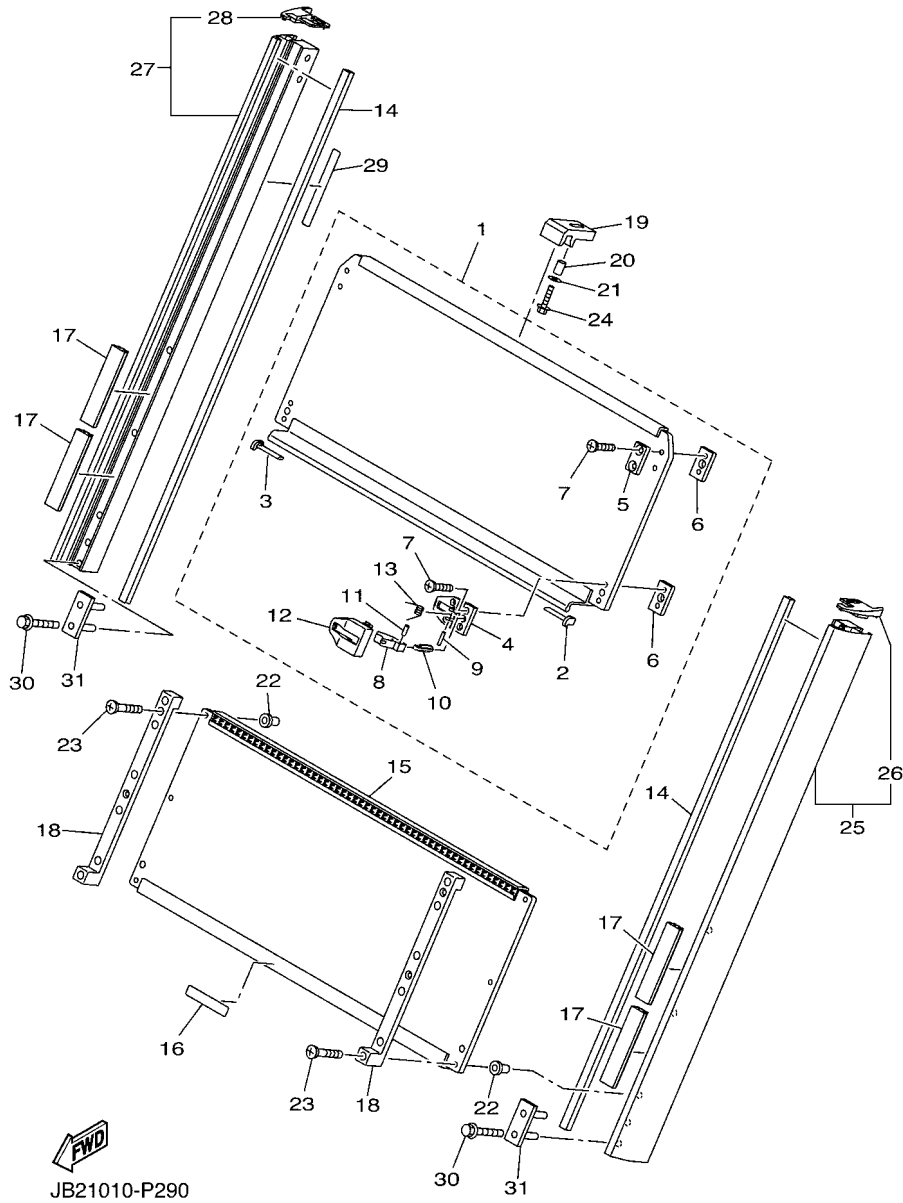
FIG. 13 WINDSHIELD(SPLIT TYPE)



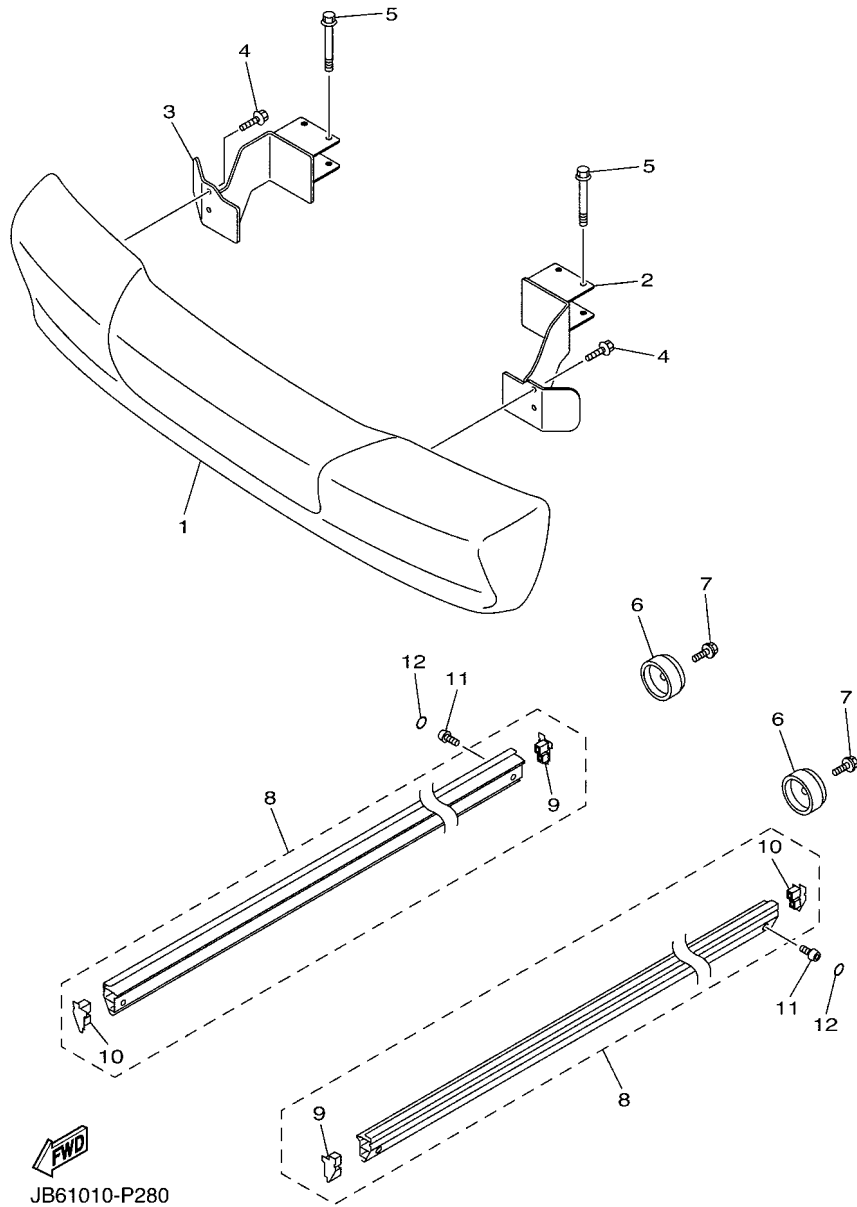
REF. NO.	PART NO.	DESCRIPTION	JB53				REMARKS
1	JB2-77201-02	UPPER WINDSHIELD ASSY	1				
2	JB2-77213-00	.TRIM, UPPER	1				
3	JB2-77214-00	.TRIM, LOWER	1				
4	JB2-77261-00	.LINING, SHROUD 1	2				
5	JB2-77262-00	.LINING, SHROUD 2	2				
6	JX4-77217-00	.NUT, WIND SHIELD	4				
7	98780-06014	.SCREW, FLAT HEAD	8				
8	JY3-77223-00	.FASTNER	2				
9	91690-20020	.PIN, SPRING	2				
10	JY2-77212-10	.BOLT, WIND SHIELD	2				
11	91690-30012	.PIN, SPRING	2				
12	JY3-77263-01	.LINING, SHROUD 3	2				
13	JY3-77174-00	.SPRING 1	2				
14	JB2-77233-01	TRIM, 7	2				
15	JB2-77202-02	LOWER WINDSHIELD ASSY	1				
16	JY4-77768-10	LABEL, WARNING 8	1				
17	JB2-77283-00	STRIPE 3	4				
18	JB2-77271-00	DAMPER, NOISE 11	2				
19	JB2-77275-00	DAMPER, NOISE 15	1				
20	90387-06553	COLLAR	1				
21	90201-06020	WASHER, PLATE	1				
22	90179-06020	NUT	6				
23	98780-06035	SCREW, FLAT HEAD	6				
24	95880-06025	BOLT, FLANGE	1				
25	JB2-7830A-00	ROOF SUPPORT ASSY 1	1				
26	JB2-7813F-00	.COVER, SIDE PILLAR (L.H)	1				
27	JB2-7830B-00	ROOF SUPPORT ASSY 2	1				



FIG. 13 WINDSHIELD(SPLIT TYPE)



REF. NO.	PART NO.	DESCRIPTION	JB53				REMARKS
28	JB2-7813G-00	.COVER, SIDE PILLAR (R.H)	1				
29	JY2-7829A-20	PLATE, CAUTION	1				
30	95812-08055	BOLT, FLANGE	4				
31	JX4-7831L-00	REINFORCEMENT, ROOF SUPPORT 1	2				
-----							
-----							
-----							
-----							
-----							
-----							
-----							
-----							



**FIG. 14 BUMPER**

REF. NO.	PART NO.	DESCRIPTION	JB63	REMARKS
1	JB2-77510-00	FRONT BUMPER COMP.	1	
2	JX4-78164-00	STAY, FRONT BUMPER (L.H)	1	
3	JX4-78165-00	STAY, FRONT BUMPER (R.H)	1	
4	95822-06012	BOLT, FLANGE	4	
5	95827-08065	BOLT, FLANGE	4	
6	JX4-77520-00	BUMPER COMP 1	2	
7	95022-08025	BOLT, FLANGE	2	
8	JB2-78180-00	SIDE SILL PLATE ASSY	2	
9	JX4-7818E-00	.CAP, PROTECTOR END 1	1	
10	JX4-7818F-00	.CAP, PROTECTOR END 2	1	
11	90111-08027	BOLT,HEX. SOCKET BUTTON	4	
12	JF7-77563-00	COVER, 3	4	

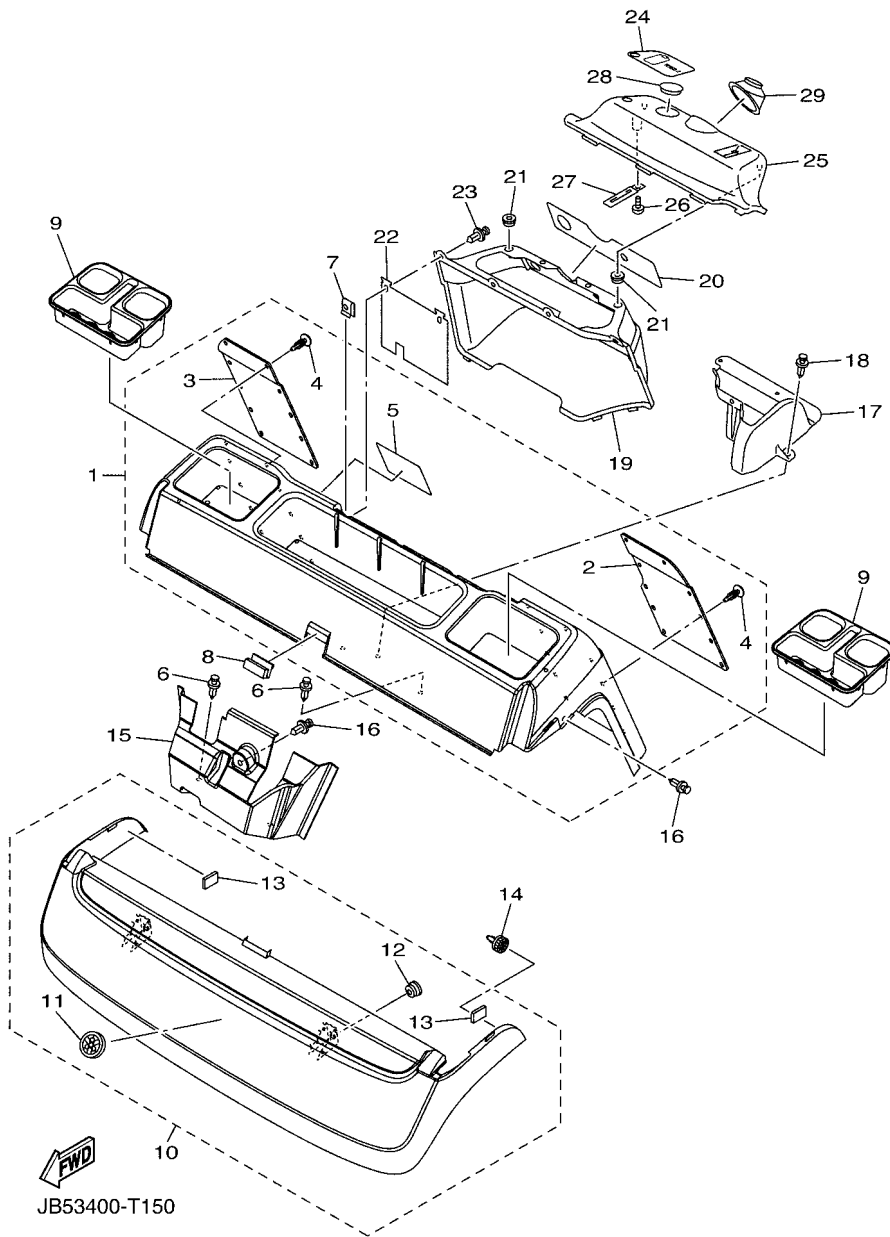
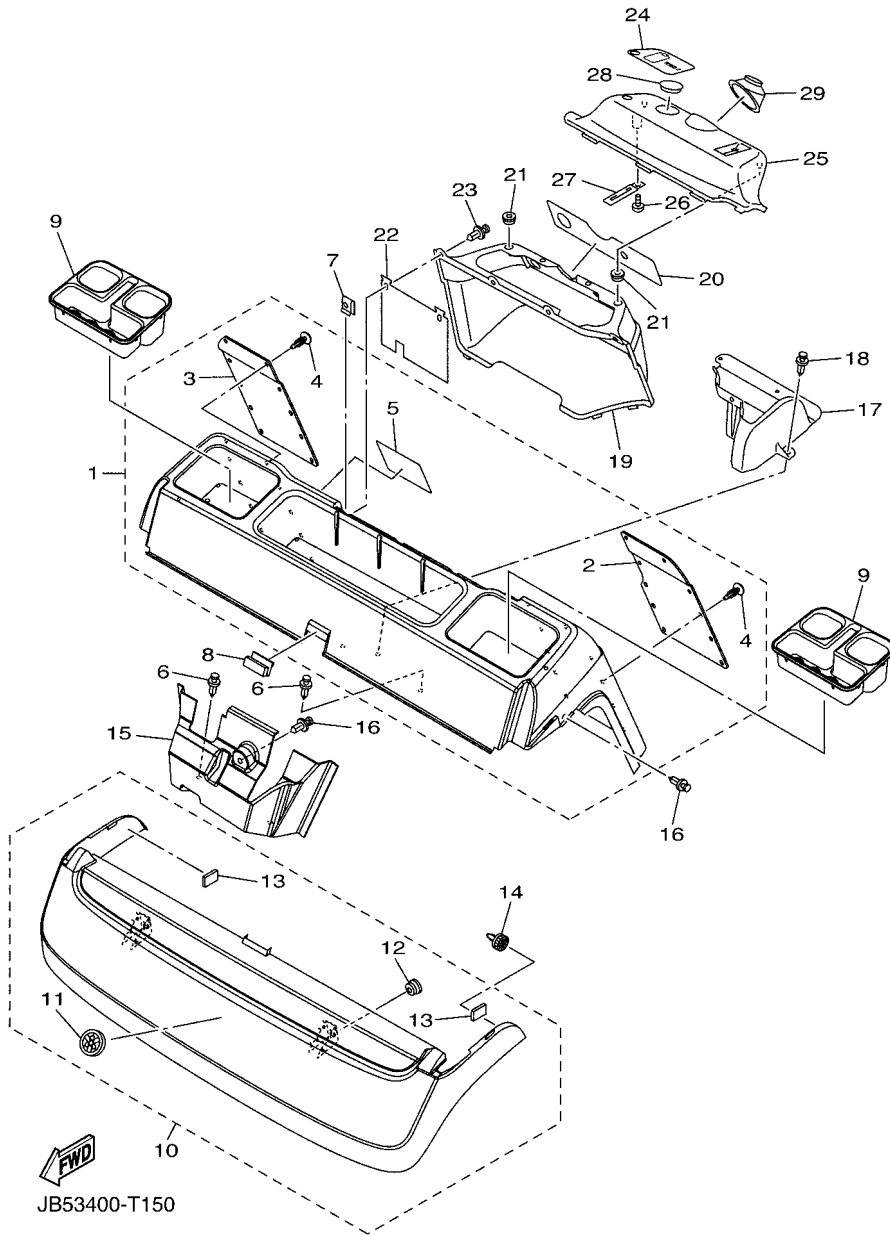


FIG. 15 BODY

REF. NO.	PART NO.	DESCRIPTION	JB53	REMARKS
1	JB2-78100-30	BODY SHELL PANEL ASSY	1	
2	JB2-78243-00	.MAT, REAR BODY SIDE (LH)	1	
3	JB2-78244-00	.MAT, REAR BODY SIDE (RH)	1	
4	90269-07064	.RIVET	20	
5	JB2-78298-20	.PLATE, CAUTION 2	1	
6	90269-10005	RIVET	4	
7	JX4-7814H-00	HOOK, BODY LOCK	4	
8	JY2-78328-20	SPACER 1	1	
9	JX4-7835E-00	HOLDER, BEVERAGE	2	
10	JX4-78101-00	BODY SHELL PANEL SUB-ASSY 1	1	UR FOR RW
	JX4-78101-60	BODY SHELL PANEL SUB-ASSY 1	1	UR FOR DNGM3
	JX4-78101-20	BODY SHELL PANEL SUB-ASSY 1	1	UR FOR DRMD
	JX4-78101-30	BODY SHELL PANEL SUB-ASSY 1	1	UR FOR DPBMC
11	8AC-2414B-01	.EMBLEM	1	
12	90480-13398	.GROMMET	2	
13	JX4-77188-00	.STOPPER	2	
14	JX4-77157-00	PIN, HINGE	2	
15	JY2-78113-00	PANEL, SIDE	1	
16	90269-10005	RIVET	3	
17	JB2-27411-00	FOOTREST 1	1	
18	90269-10005	RIVET	2	
19	JB2-77711-00	PANEL, INSTRUMENT	1	
20	JB5-77741-00	INDICATOR 1	1	
21	90480-13567	GROMMET	2	
22	JX2-78181-00	PLATE 1	1	
23	90269-10005	RIVET	4	
24	JB9-77742-00	INDICATOR 2	1	



**FIG. 15 BODY**

REF. NO.	PART NO.	DESCRIPTION	JB53				REMARKS
25	JB3-78139-00	CAP, END	1				
26	97702-50014	SCREW, TAPPING	2				
27	90462-05059	CLAMP	2				
28	JB6-7811V-00	PROTECTOR 1	1				
29	JX4-78273-00	COVER, HOLE	1				

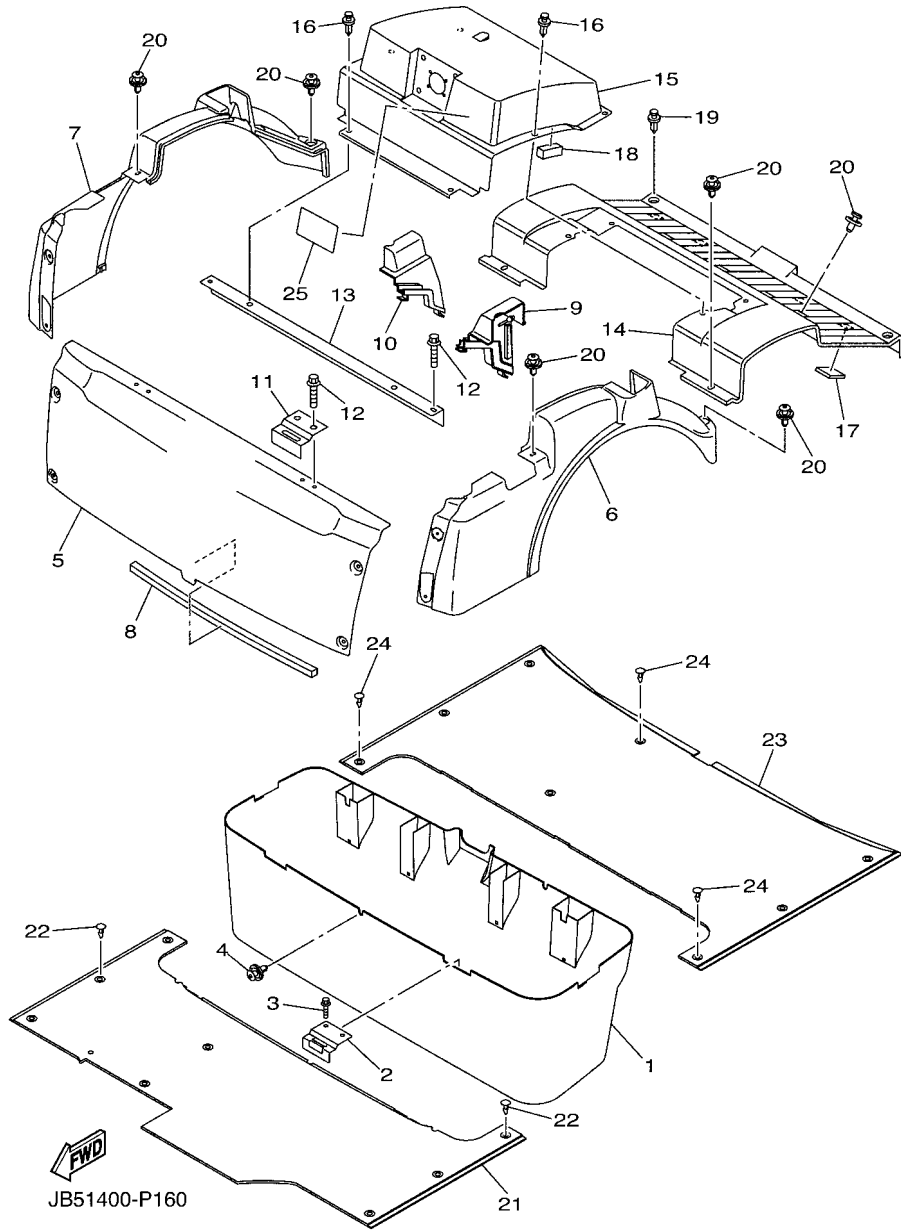
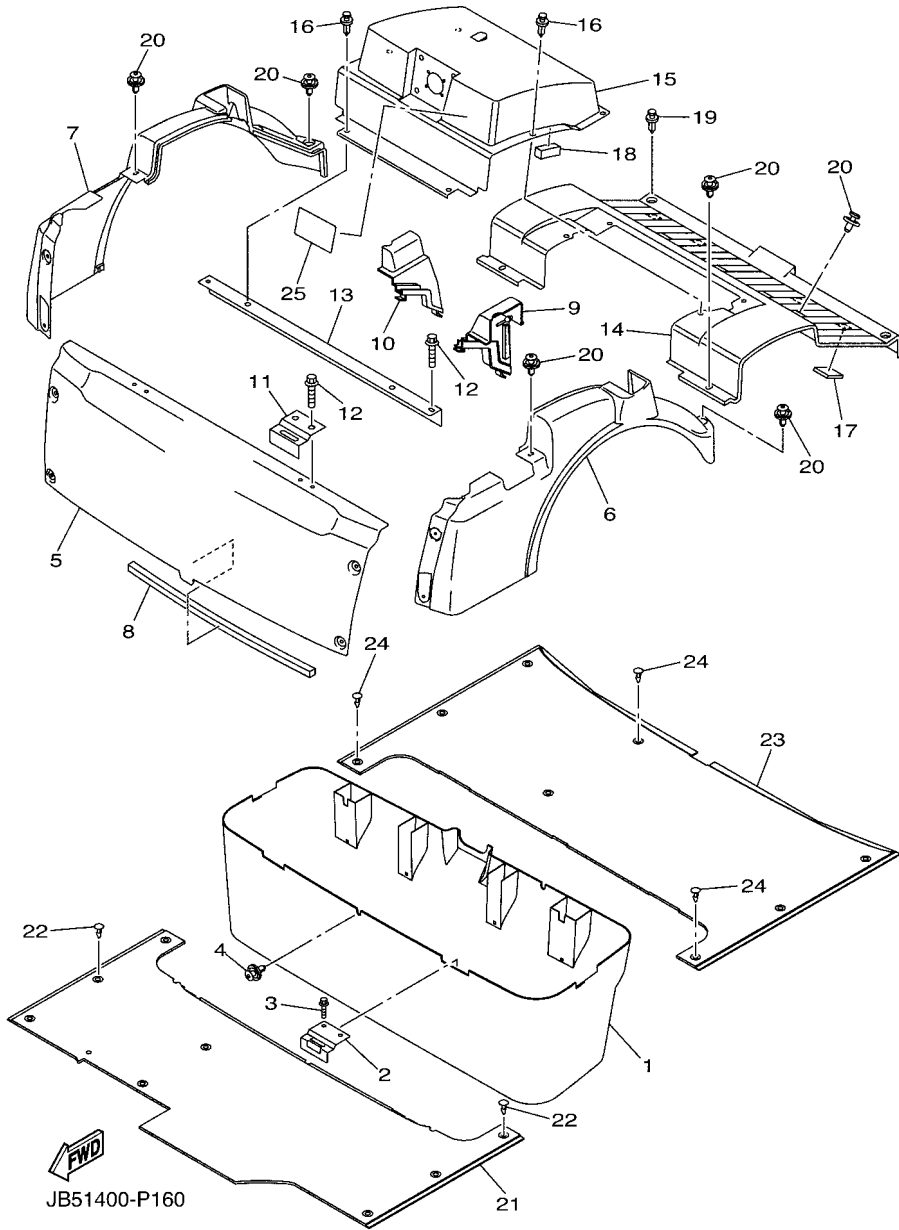


FIG. 16 BODY 2

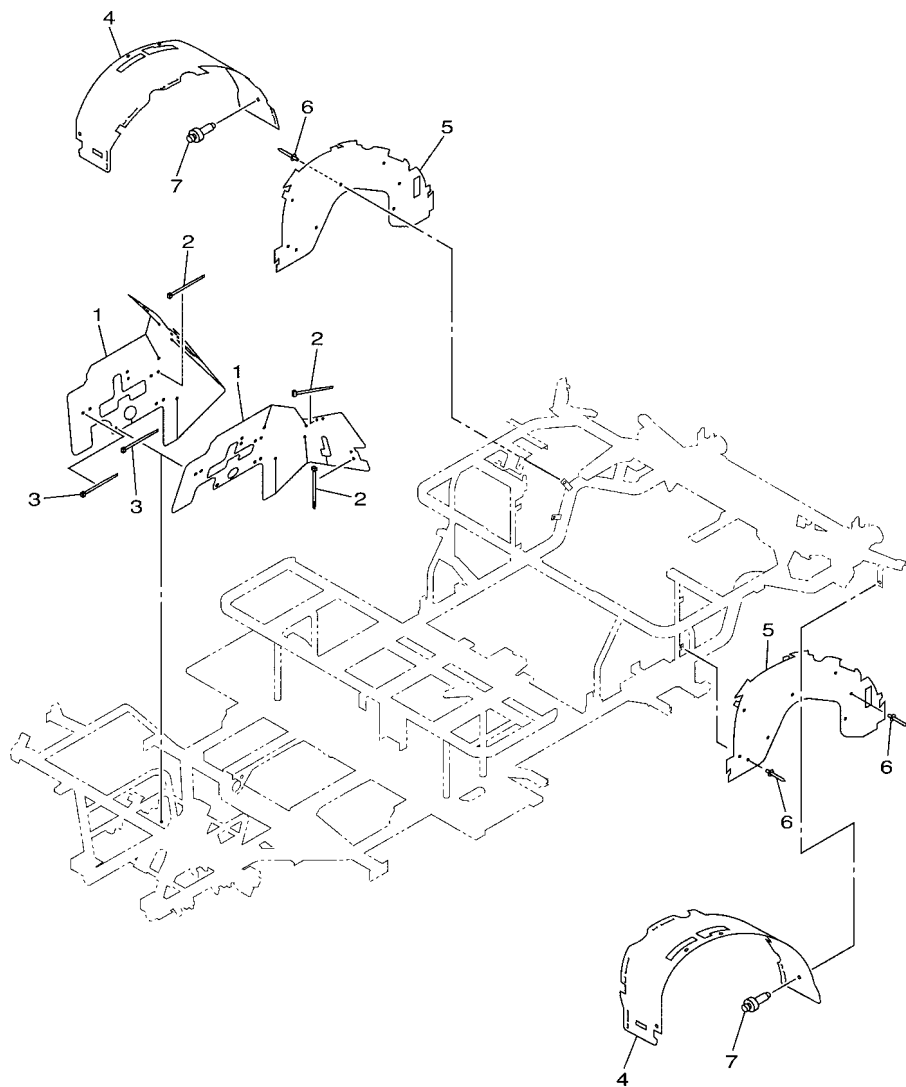
REF. NO.	PART NO.	DESCRIPTION	JB53		REMARKS
1	JB8-78141-00	PANEL, INTERMEDIATE BODY	1		UR FOR RW
	JB8-78141-60	PANEL, INTERMEDIATE BODY	1		UR FOR DNGM3
	JB8-78141-20	PANEL, INTERMEDIATE BODY	1		UR FOR DRMD
	JB8-78141-30	PANEL, INTERMEDIATE BODY	1		UR FOR DPBMC
2	JY2-78427-00	HINGE, SEAT 2	2		
3	95802-06030	BOLT, FLANGE	4		
4	90269-07010	RIVET	3		
5	JY2-78142-00	PANEL, REAR BODY	1		
6	JB3-78130-00	SHELL SIDE PANEL ASSY 1	1		UR FOR RW
	JB3-78130-60	SHELL SIDE PANEL ASSY 1	1		UR FOR DNGM3
	JB3-78130-20	SHELL SIDE PANEL ASSY 1	1		UR FOR DRMD
	JB3-78130-30	SHELL SIDE PANEL ASSY 1	1		UR FOR DPBMC
7	JB3-78140-00	SHELL SIDE PANEL ASSY 2	1		UR FOR RW
	JB3-78140-60	SHELL SIDE PANEL ASSY 2	1		UR FOR DNGM3
	JB3-78140-20	SHELL SIDE PANEL ASSY 2	1		UR FOR DRMD
	JB3-78140-30	SHELL SIDE PANEL ASSY 2	1		UR FOR DPBMC
8	JY3-78329-00	SPACER 2	1		
9	JX4-7832H-00	GROMMET, ROOF SUPPORT 3	1		
10	JX4-7833H-00	GROMMET, ROOF SUPPORT 4	1		
11	JX4-78427-00	HINGE, SEAT 2	2		
12	95802-06040	BOLT, FLANGE	6		
13	JX4-2254R-01	SUPPORT, BODY MOUNTING	1		
14	JY3-78150-10	INSPECTION LID ASSY	1		
15	JY3-7813H-00	COVER, VENTILATOR	1		
16	90269-10005	RIVET	6		
17	JX4-7814E-00	SEAL, BODY SIDE 1	4		
18	JY3-78305-00	DAMPER	1		



**FIG. 16 BODY 2**

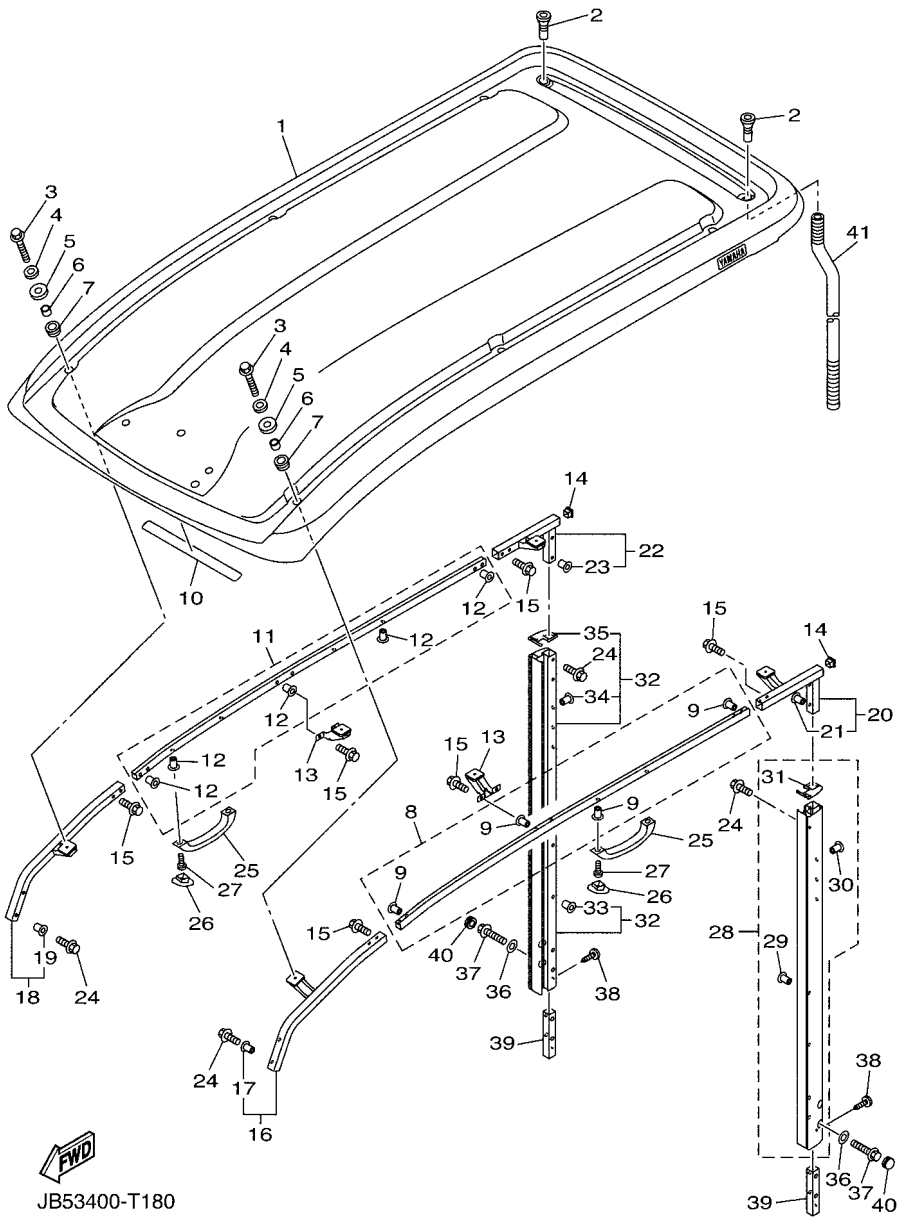
REF. NO.	PART NO.	DESCRIPTION	JB53	REMARKS
19	90269-10005	RIVET	2	
20	90269-07010	RIVET	16	
21	JB8-78231-00	MAT, MAIN FLOOR 1	1	
22	90269-07064	RIVET	9	
23	JB8-78241-00	MAT, REAR FLOOR	1	
24	90269-07064	RIVET	8	
25	JT2-77766-22	LABEL, WARNING 6	1	

**FIG. 17 BODY FITTING**



JB31010-P190

REF. NO.	PART NO.	DESCRIPTION	JB53	REMARKS
1	JB2-78187-00	FLAP, FRONT FENDER	2	
2	90465-13152	CLAMP	8	
3	90465-13275	CLAMP	4	
4	JB2-78191-00	PANEL, REAR FENDER 1	2	
5	JB2-78192-00	PANEL, REAR FENDER 2	2	
6	90267-48101	RIVET, BLIND	18	
7	90269-10005	RIVET	4	

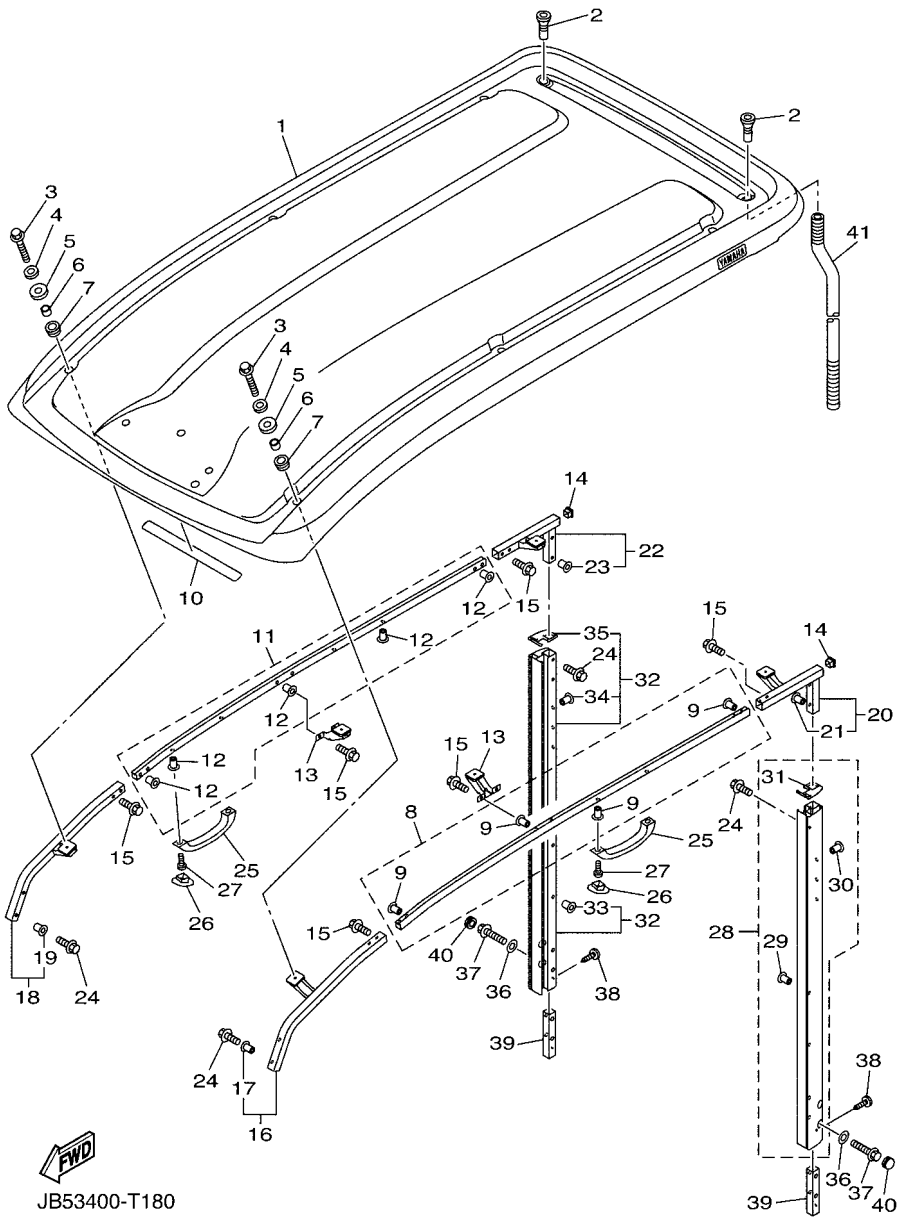


JB53400-T180

FIG. 18 SUN ROOF

REF. NO.	PART NO.	DESCRIPTION	QTY	REMARKS
1	JB3-78314-00	COVER, SUN ROOF	1	
2	JX4-7832F-00	GROMMET, ROOF SUPPORT 1	2	
3	95880-06030	BOLT, FLANGE	6	
4	90201-06115	WASHER, PLATE	6	
5	90201-06116	WASHER, PLATE	6	
6	90387-15019	COLLAR	6	
7	90480-25004	GROMMET	6	
8	JB2-78392-00	MEMBER, ROOF FRAME	1	
9	90179-06636	.NUT	8	
10	JB5-78299-00	PLATE, CAUTION	1	
11	JB2-78393-00	MEMBER, ROOF FRAME 2	1	
12	90179-06636	.NUT	10	
13	JB2-7833K-10	BRACKET, ROOF REAR	2	
14	JX7-7836H-00	CAP, BAG SUPPORT	2	
15	95880-06016	BOLT, FLANGE	12	
16	JB3-7830E-00	SUNROOF PIPE ASSY 1	1	
17	90179-06021	.NUT	2	
18	JB3-7830E-10	SUNROOF PIPE ASSY 1	1	
19	90179-06021	.NUT	2	
20	JB3-7830F-00	SUNROOF PIPE ASSY 2	1	
21	90179-06021	.NUT	2	
22	JB3-7830F-10	SUNROOF PIPE ASSY 2	1	
23	90179-06021	.NUT	2	
24	95880-06020	BOLT, FLANGE	8	
25	JF7-78214-00	GRIP, HAND	3	
26	J50-78274-10	COVER, HOLE 2	6	
27	90157-06068	SCREW, PAN HEAD	6	

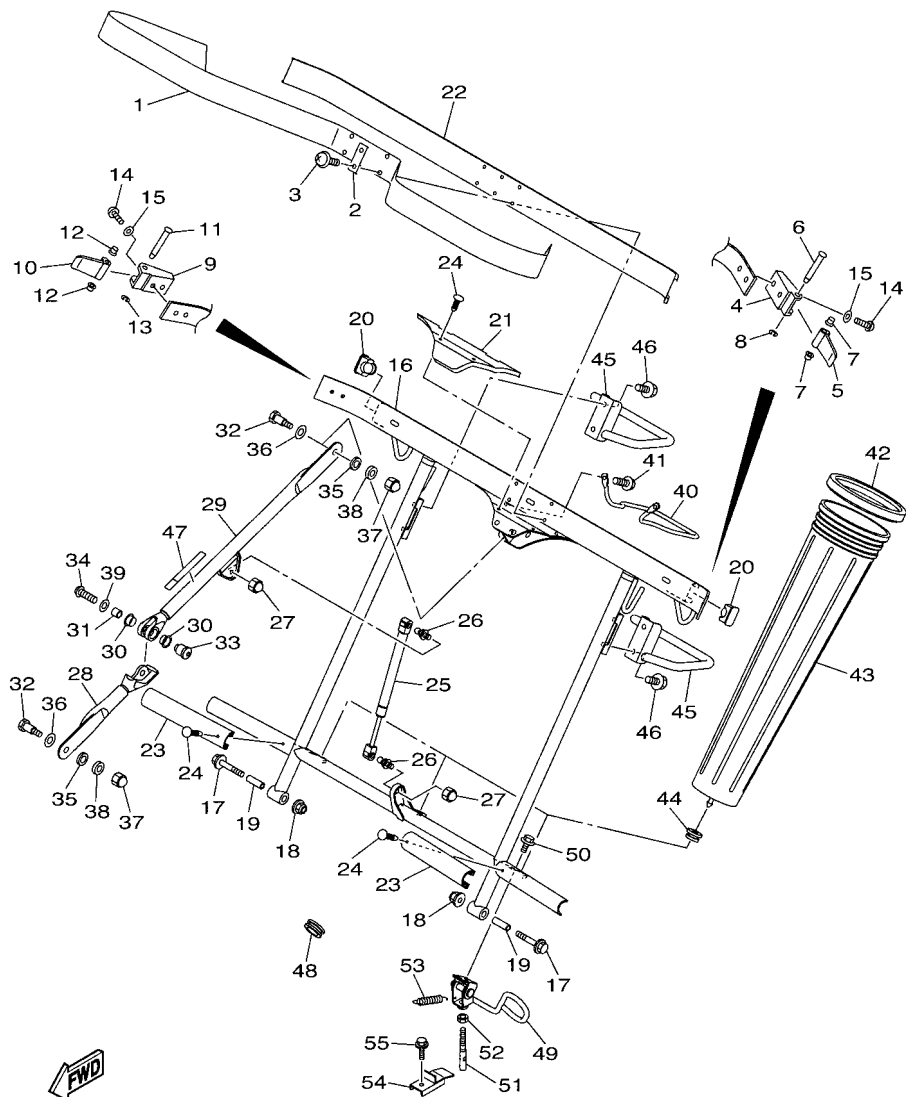




**FIG. 18 SUN ROOF**

REF. NO.	PART NO.	DESCRIPTION	JB53	REMARKS
28	JB2-7830C-00	ROOF SUPPORT ASSY 3	1	
29	90179-08689	.NUT	2	
30	90179-06059	.NUT	3	
31	JB2-7817F-00	.COVER, REAR PILLER (L.H)	1	
32	JB2-7830D-00	ROOF SUPPORT ASSY 4	1	
33	90179-08689	.NUT	2	
34	90179-06059	.NUT	3	
35	JB2-7817G-00	.COVER, REAR PILLER (R.H)	1	
36	90201-08730	WASHER, PLATE	4	
37	95812-08055	BOLT, FLANGE	4	
38	90269-06003	RIVET	2	
39	JB2-7831N-00	REINFORCEMENT, ROOF SUPPORT 3	2	
40	90338-24204	PLUG	2	
41	JX4-78334-01	HOSE	2	

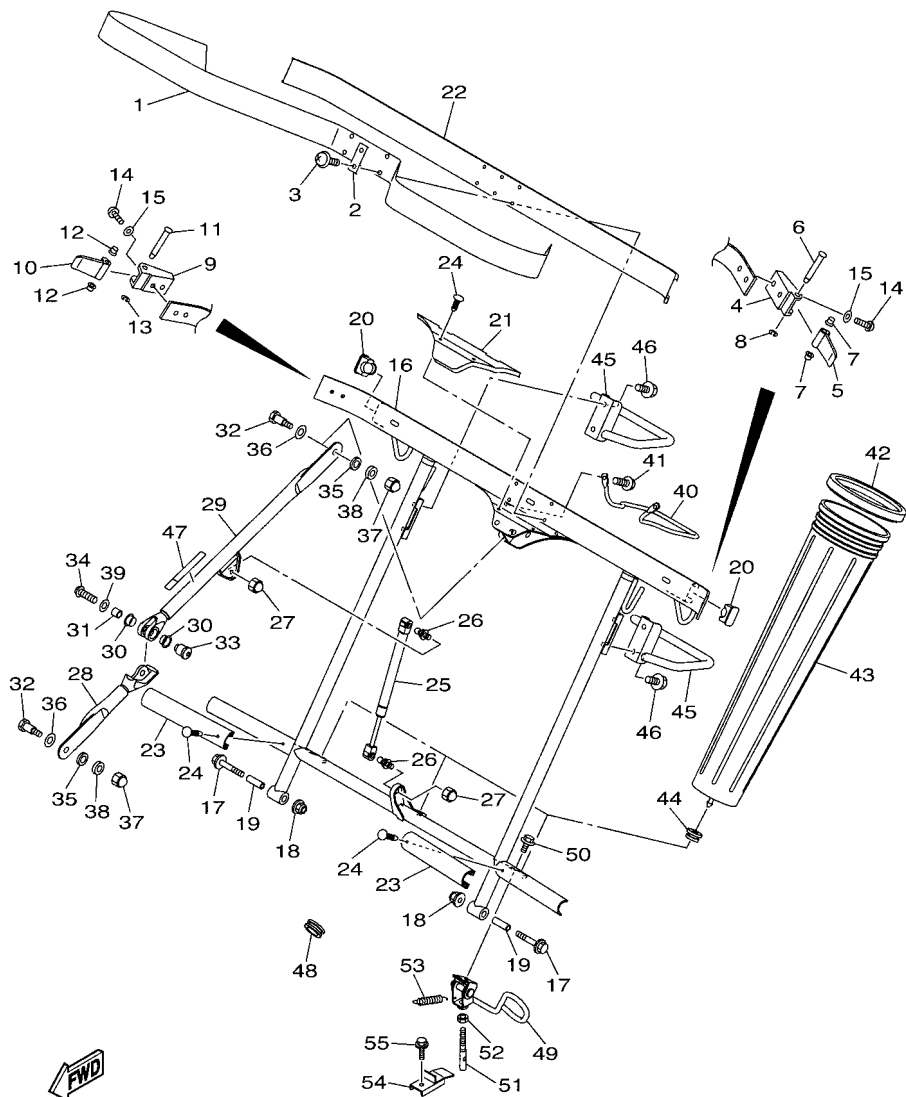
FIG. 19 CARRIER(MOVABLE)



JB53400-T190

REF. NO.	PART NO.	DESCRIPTION	JB53				REMARKS
1	JB2-78355-00	BAND	1				
2	JF7-78367-00	PLATE, ANCHOR	2				
3	90159-06055	SCREW, WITH WASHER	4				
4	J17-78157-01	BASE, LOCK	1				
5	J17-78368-01	LEVER, LOCK	1				
6	J17-78369-00	PIN, LEVER	1				
7	90386-06108	BUSH	2				
8	99080-05600	CIRCLIP	1				
9	J17-78157-01	BASE, LOCK	1				
10	J17-78368-01	LEVER, LOCK	1				
11	J17-78369-00	PIN, LEVER	1				
12	90386-06108	BUSH	2				
13	99080-05600	CIRCLIP	1				
14	90157-06011	SCREW, PAN HEAD	4				
15	90201-06106	WASHER, PLATE	4				
16	JB2-7835J-10	SUPPORT, BAG LOWER 3	1				
17	95812-08060	BOLT, FLANGE	2				
18	95602-08200	NUT, U FLANGE	2				
19	90387-08031	COLLAR	2				
20	JX4-7836H-00	CAP, BAG SUPPORT	2				
21	JB2-78178-00	COVER, EXTENSION PLATE	1				
22	JB2-78356-00	PAD, BAG SUPPORT	1				
23	JX4-78364-00	PAD, BAG SUPPORT 3	2				
24	90269-05055	RIVET	4				
25	JY2-28415-01	DAMPER 1	1				
26	JY2-2474E-00	ARM	2				
27	95307-08800	NUT	2				

FIG. 19 CARRIER(MOVABLE)

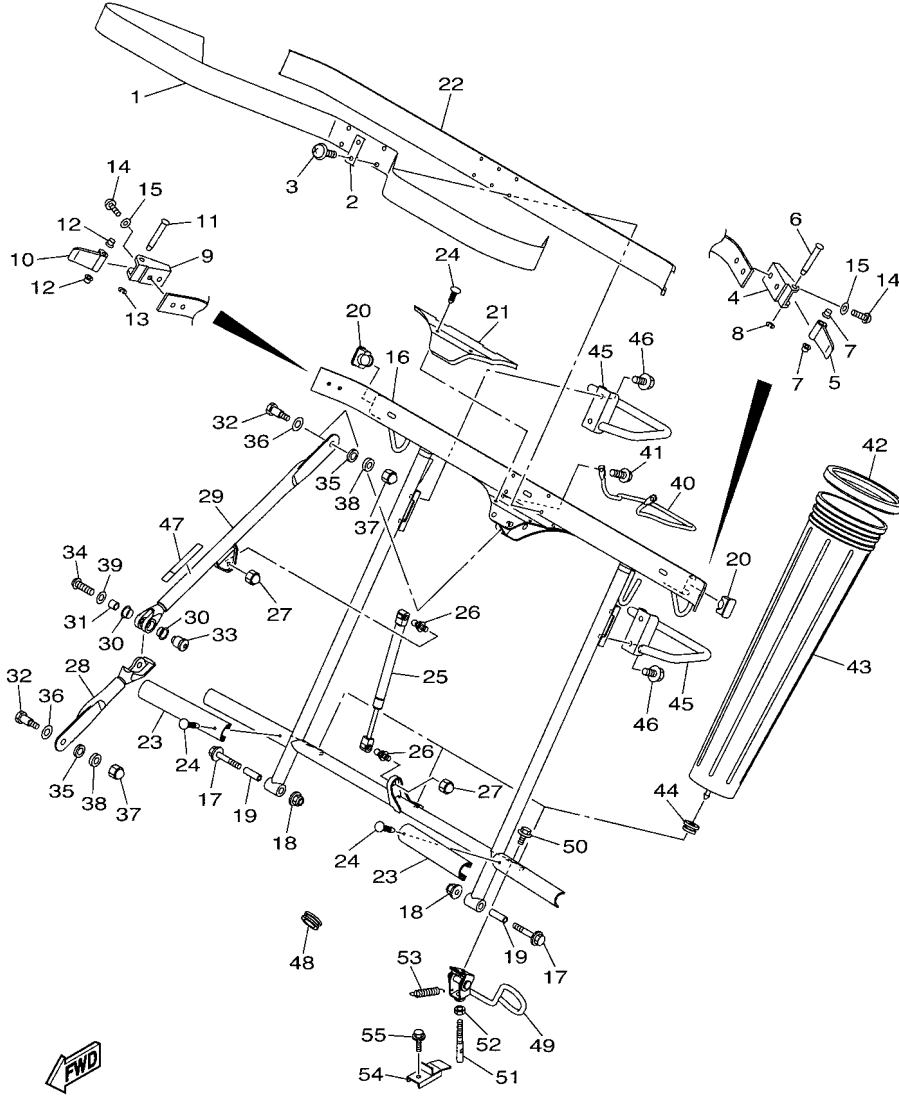


JB53400-T190

REF. NO.	PART NO.	DESCRIPTION	JB53				REMARKS
28	JB2-78375-00	SUPPORT 1	1				
29	JB2-78376-00	SUPPORT 2	1				
30	90381-18004	BUSH, SOLID	2				
31	90387-12053	COLLAR	1				
32	90109-10473	BOLT	2				
33	JB2-78145-00	NUT, REAR BODY MOUNTING	1				
34	90111-08013	BOLT,HEX. SOCKET BUTTON	1				
35	90201-122H1	WASHER, PLATE	2				
36	90201-120T5	WASHER, PLATE	2				
37	95307-10800	NUT	2				
38	90201-102J5	WASHER, PLATE	2				
39	90201-08101	WASHER, PLATE	1				
40	JB2-78323-00	BRACKET 1	1				
41	95024-06016	BOLT, FLG.(SMALL HEAD)	2				
42	JY2-78374-00	TRIM, UPPER	3				
43	JB2-78389-00	CASE 2	3				
44	90480-08216	GROMMET	3				
45	JB2-78358-00	HOLDER 2	2				
46	95802-08012	BOLT, FLANGE	4				
47	JY2-78483-30	LABEL WARNING	1				
48	90338-15004	PLUG	1				
49	JB2-78380-00	LOCK ASSY	1				
50	95880-06012	BOLT, FLANGE	2				
51	JY2-78369-00	PIN, LEVER	1				
52	95380-08600	NUT	1				
53	90506-10001	SPRING, TENSION	1				
54	JY2-7831W-00	BRACKET, BAG SUPPORT 2	1				

**FIG. 19 CARRIER(MOVABLE)**

REF. NO.	PART NO.	DESCRIPTION	JB53				REMARKS
55	95880-06012	BOLT, FLANGE	1				



JB53400-T190

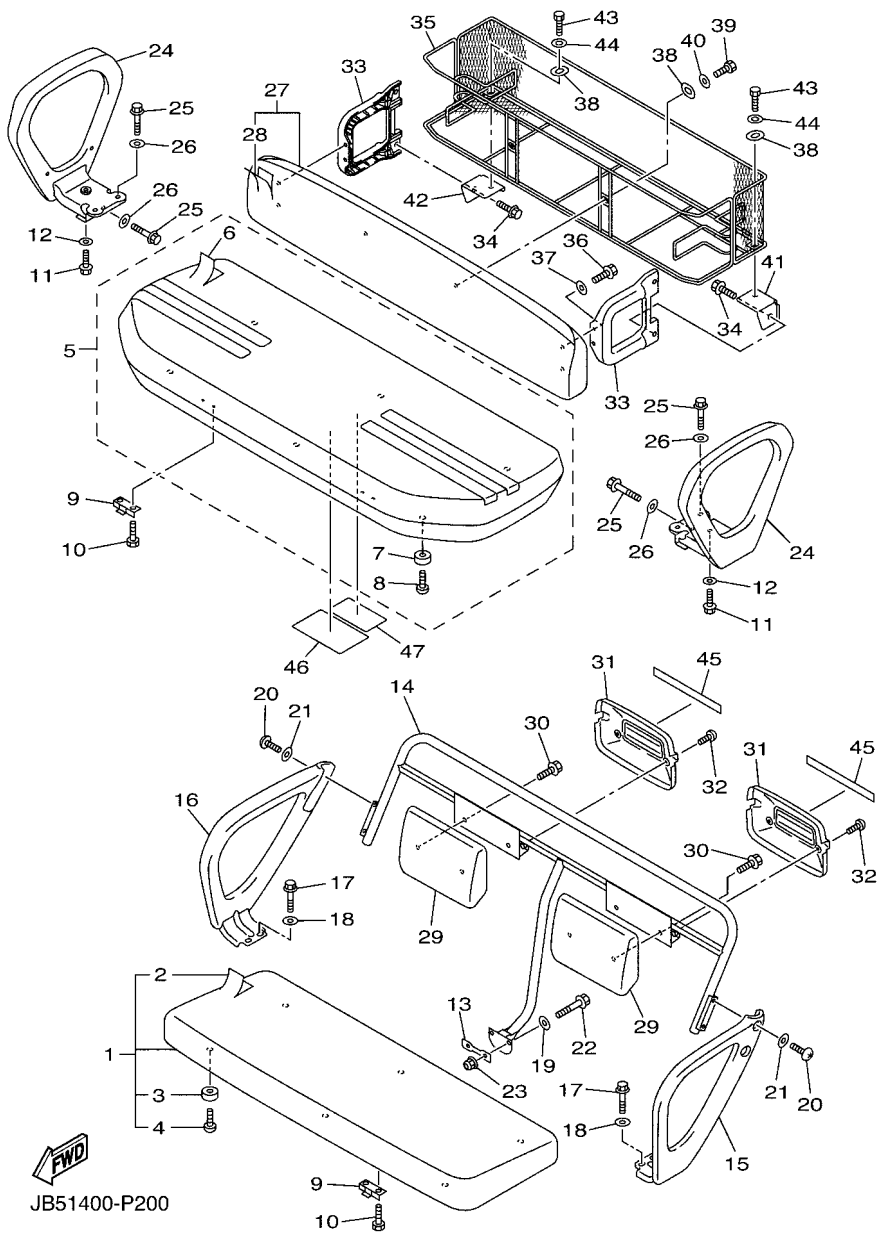


FIG. 20 SEAT

REF. NO.	PART NO.	DESCRIPTION	JB53			REMARKS
1	JB8-78410-10	SEAT ASSY	1			
2	JB8-78405-00	.COVER, SEAT	1			
3	JF7-78433-00	.DAMPER, SEAT SUPPORT	6			
4	97702-50016	.SCREW, TAPPING	6			
5	JB8-78420-00	SEAT ASSY 2	1			
6	JB8-78404-00	.COVER, SEAT	1			
7	JF7-78433-00	.DAMPER, SEAT SUPPORT	6			
8	97702-50016	.SCREW, TAPPING	6			
9	JR7-78426-00	HINGE, SEAT 1	4			
10	97022-06025	BOLT, HEXAGON	8			
11	95807-06020	BOLT, FLANGE	2			
12	92902-08200	WASHER	2			
13	JB2-78439-00	WASHER, SEAT	1			
14	JB8-78423-00	SUPPORT, SEAT BACK	1			
15	JB8-78362-01	ARM REST 2	1			
16	JB8-7836L-01	ARM REST 3	1			
17	90105-08096	BOLT, FLANGE	4			
18	90201-08730	WASHER, PLATE	4			
19	92902-08200	WASHER	2			
20	90149-08291	SCREW	4			
21	90201-08026	WASHER, PLATE	4			
22	90105-08198	BOLT, FLANGE	2			
23	95602-08200	NUT, U FLANGE	2			
24	JB8-78361-01	ARM REST 1	2			
25	90105-08252	BOLT, FLANGE	6			
26	90201-08730	WASHER, PLATE	6			
27	JB8-78407-00	REAR SEAT SUB-ASSY, BACK	1			

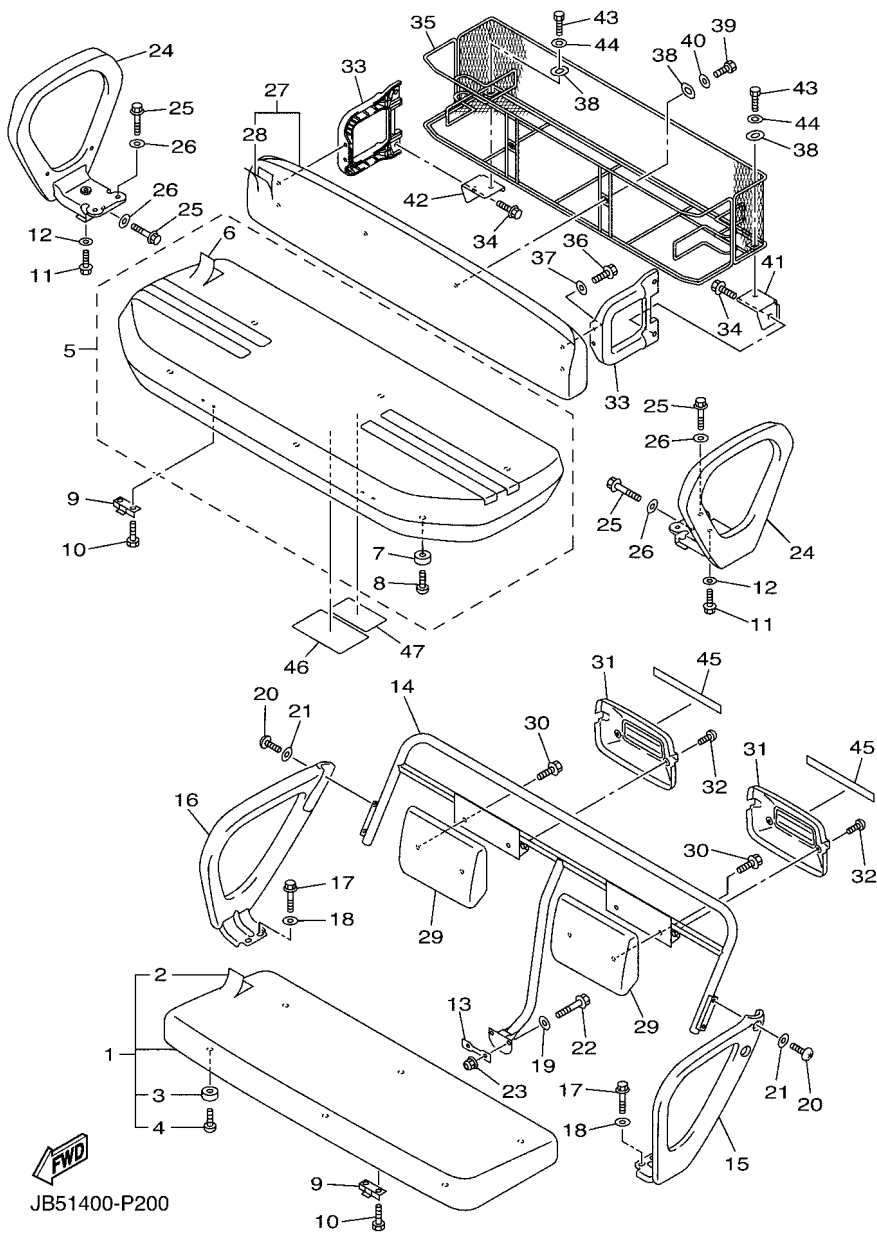
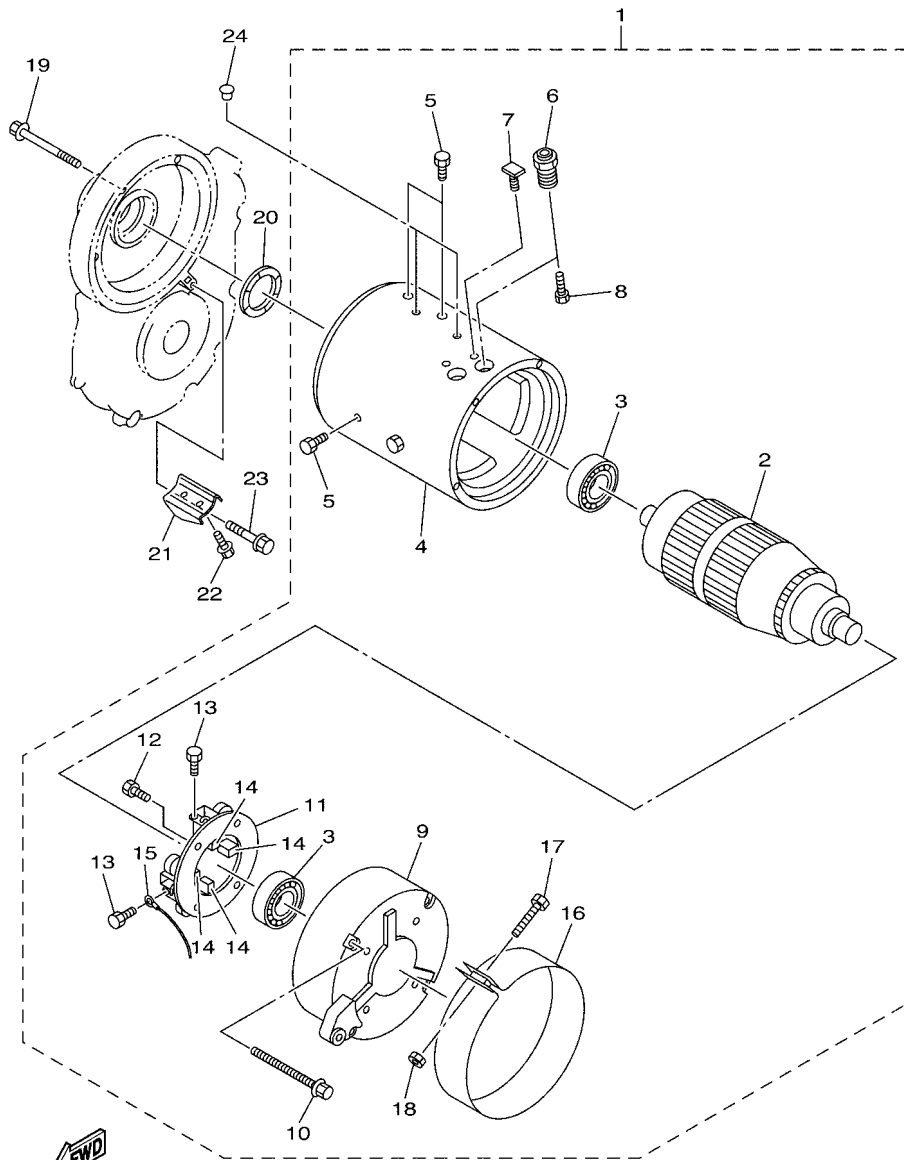


FIG. 20 SEAT

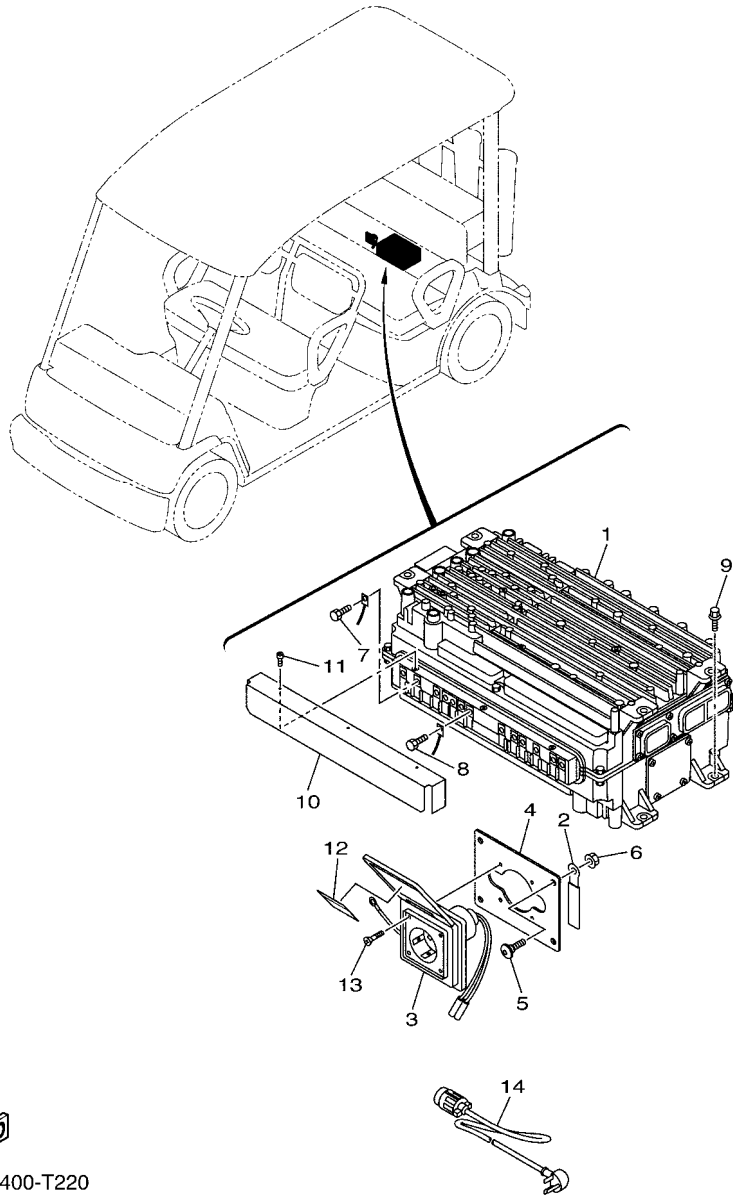
REF. NO.	PART NO.	DESCRIPTION	JB53				REMARKS
28	JB8-78418-00	.COVER, SEAT	1				
29	95802-06016	BOLT, FLANGE	4				
30	JB6-78413-00	COVER, SEAT BACK	2				
31	98980-06012	SCREW, BIND	4				
32	JR7-78402-01	SEAT SUB ASSY, BACK	2				
33	JY2-78484-00	SUPPORT, SEAT 1	2				
34	95880-08025	BOLT, FLANGE	4				
35	JY2-7810M-00	REAR STORAGE BOX COMP.	1				
36	95880-06020	BOLT, FLANGE	4				
37	90201-06020	WASHER, PLATE	4				
38	JY2-78478-00	WASHER, PLATE	4				
39	97080-06020	BOLT	2				
40	90201-06049	WASHER, PLATE	2				
41	JX4-7842F-00	SUPPORT, SEAT (L.H)	1				
42	JX4-7842G-00	SUPPORT, SEAT (R.H)	1				
43	97080-06016	BOLT	2				
44	90201-06049	WASHER, PLATE	2				
45	JX4-78297-01	PLATE, CAUTION 1	2				
46	JY8-77765-21	LABEL, WARNING 5	1				
47	JX5-78297-11	PLATE, CAUTION 1	1				



JX31010-D231

FIG. 21 ELECTRIC MOTOR

REF. NO.	PART NO.	DESCRIPTION	JBS3				REMARKS
1	JY8-81890-02	MOTOR ASSY	1				
2	JT2-81150-00	.ARMATURE ASSY	1				
3	JT2-81157-00	.BEARING 1	2				
4	JX3-81160-00	.FIELD COIL ASSY	1				
5	JT2-81152-00	.BOLT	8				
6	JT2-83325-00	.BOLT, STUD	4				
7	JT2-81135-00	.SCREW, STATOR	4				
8	JT2-81252-00	.BOLT	4				
9	JX3-81822-00	.BRACKET, STARTING MOTOR	1				
10	JT2-81352-00	.BOLT	4				
11	JT2-8184J-00	.HOLDER, BRUSH	1				
12	JT2-81452-00	.BOLT	4				
13	JT2-81652-00	.BOLT	4				
14	JT2-81811-00	.BRUSH 1	4				
15	JT2-81218-00	.TERMINAL	2				
16	JY8-81129-00	.COVER, BRUSH	1				
17	JT2-81552-00	.BOLT	1				
18	JT2-81353-00	.NUT	1				
19	95812-06050	BOLT, FLANGE	3				
20	90206-38001	WASHER, WAVE	1				
21	JX3-81823-00	STAY, STARTING MOTOR	1				
22	95822-08014	BOLT, FLANGE	2				
23	95812-08035	BOLT, FLANGE	1				
24	90338-08174	PLUG	2				



**FIG. 22 CONTROL UNIT**

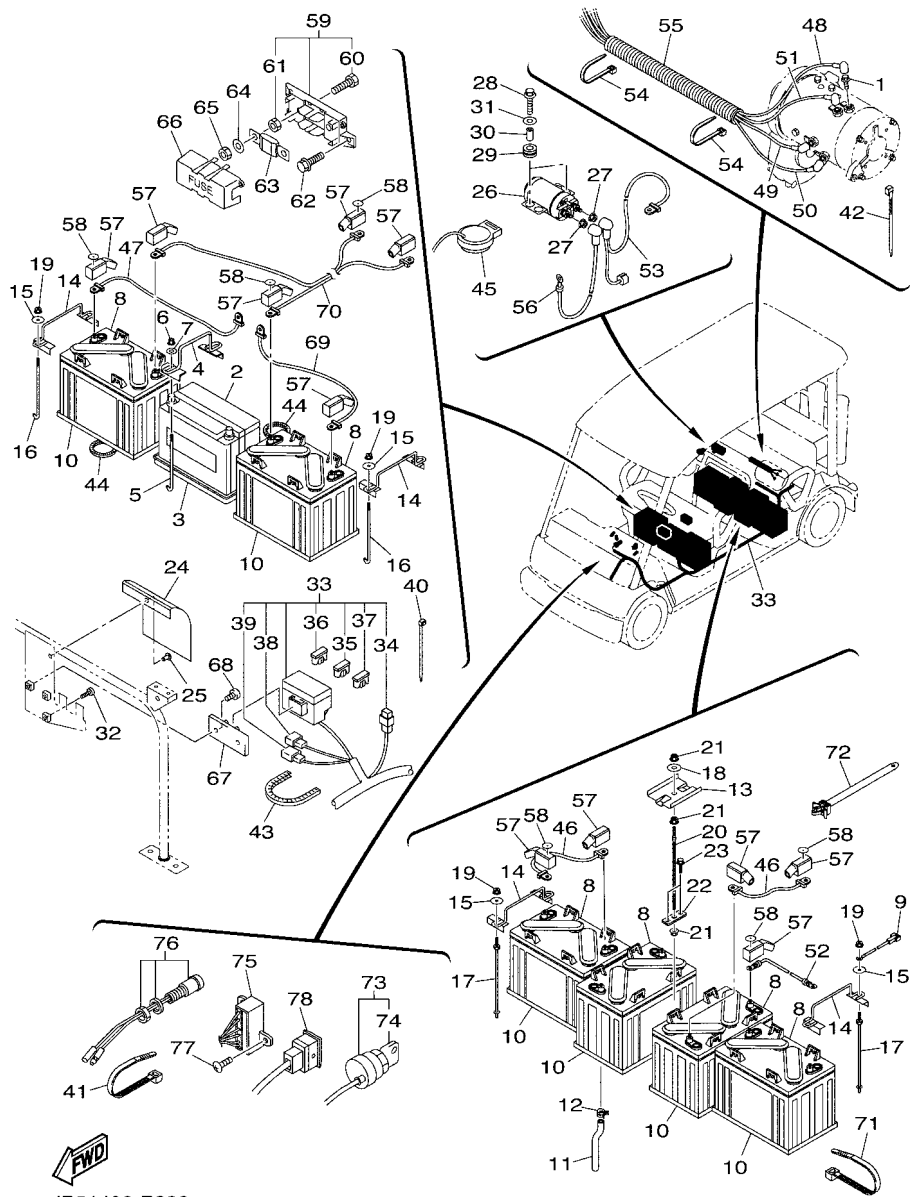
REF. NO.	PART NO.	DESCRIPTION	JB53				REMARKS
1	JB5-8A210-00	CONTROL UNIT	1				
2	90462-06007	CLAMP	1				
3	JY3-87214-00	RECEPTACLE COMP.	1				
4	JY3-86182-00	STAY, RECEPTACLE	1				
5	90150-06015	SCREW, ROUND HEAD	4				
6	95602-06200	NUT, SELF-LOCKING	1				
7	95022-06012	BOLT, FLANGE	7				
8	97022-05012	BOLT, HEXAGON	6				
9	95822-06016	BOLT, FLANGE	4				
10	JY3-86514-00	COVER, CONTROL	1				
11	97707-30110	SCREW, TAPPING	2				
12	JT2-88109-20	LABEL, CAUTION	1				
13	98780-04025	SCREW, FLAT HEAD	4				
14	JY3-81962-10	CORD COMP.	1				



JB53400-T220

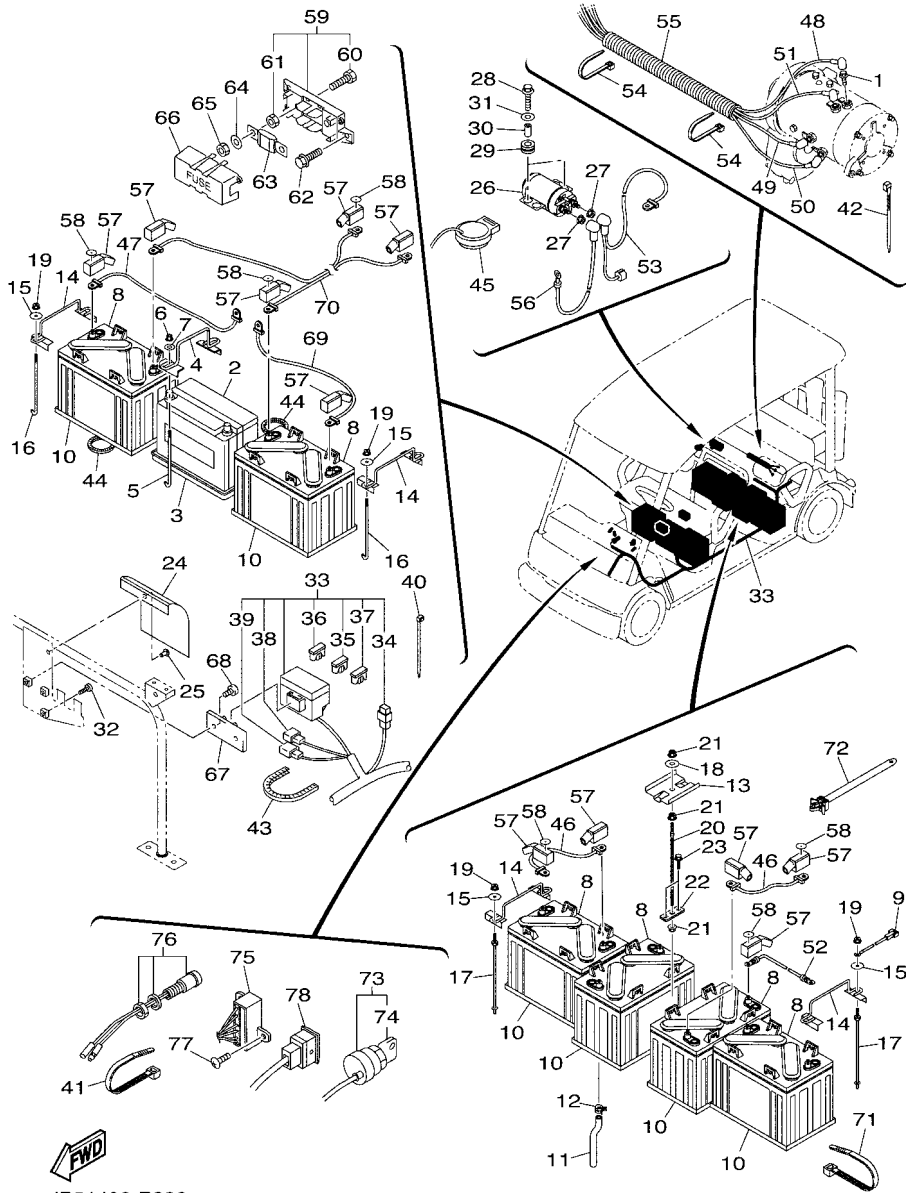


FIG. 23 ELECTRICAL 1



JB51400-P230

REF. NO.	PART NO.	DESCRIPTION	JB53	REMARKS
1	95802-08014	BOLT, FLANGE	4	
2	*	BATTERY ASSY (50B24L)	1	LM
3	JT2-82123-00	SEAT, BATTERY	1	
4	JY3-8213F-00	PLATE, BATTERY FITTING 3	1	
5	JH2-82133-00	SCREW, FITTING	2	
6	90185-06153	NUT, SELF-LOCKING	2	
7	90201-06072	WASHER, PLATE	2	
8	*	BATTERY ASSY	6	LM
9	JY8-83688-10	SENSOR ASSY	1	
10	JY8-82122-01	SEAT, BATTERY	6	
11	JY8-82353-00	HOSE	1	
12	90468-08104	CLIP	1	
13	JY8-82136-00	PLATE, BATTERY FITTING	1	
14	JY8-8213F-00	PLATE, BATTERY FITTING 3	4	
15	90201-06090	WASHER, PLATE	8	
16	J17-82133-00	SCREW, FITTING	4	
17	JY8-82133-00	SCREW, FITTING	4	
18	90201-10028	WASHER, PLATE	1	
19	95702-06500	NUT, FLANGE	8	
20	90116-10405	BOLT, STUD	1	
21	95702-10500	NUT, FLANGE	3	
22	JY8-81411-00	BASE, PLATE 1	1	
23	95822-08020	BOLT, FLANGE	2	
24	JB8-82129-00	COVER, BATTERY	1	
25	90269-07077	RIVET	1	
26	JT2-81950-01	RELAY ASSY (YZ46C-1)	1	
27	95702-08500	NUT, FLANGE	2	

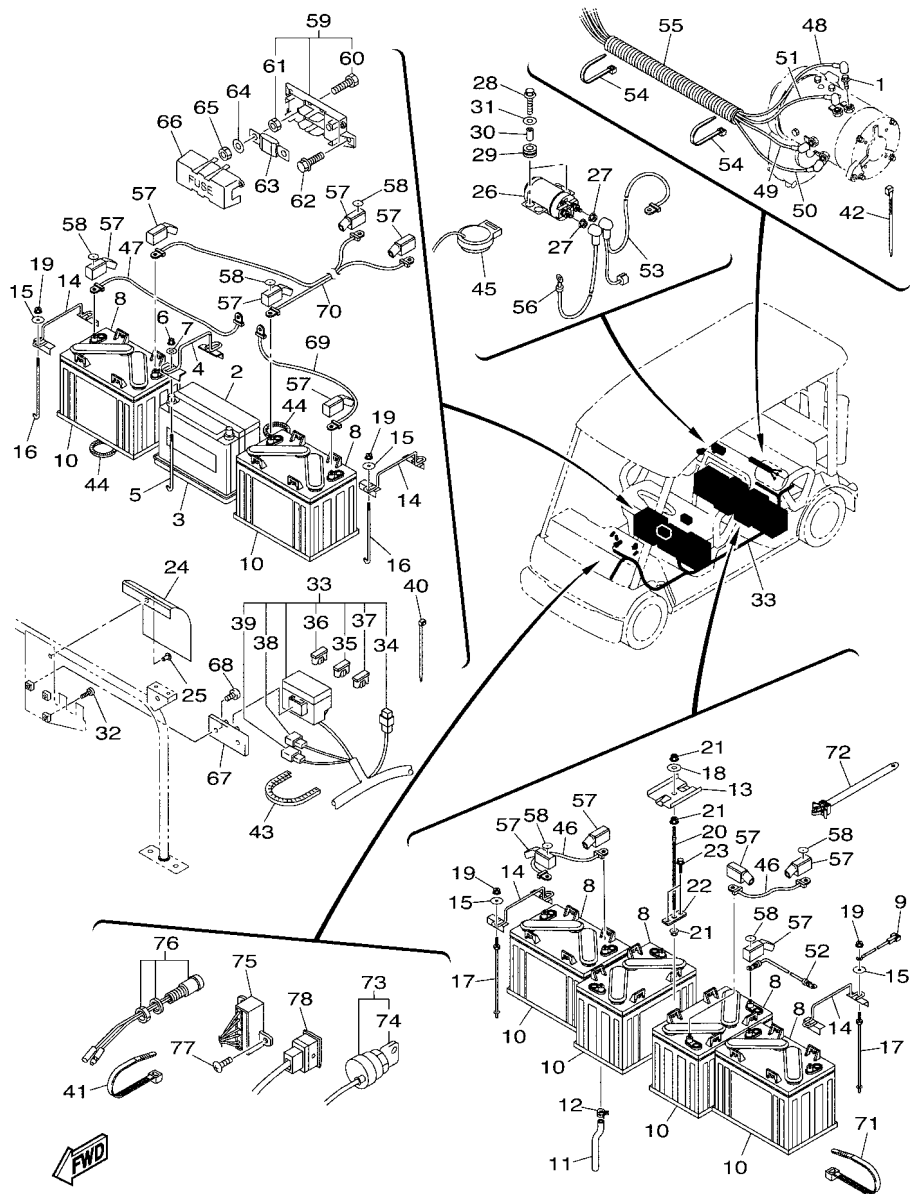


JB51400-P230

FIG. 23 ELECTRICAL 1

REF. NO.	PART NO.	DESCRIPTION	JB53				REMARKS
28	95802-06020	BOLT, FLANGE	2				
29	90480-16278	GROMMET	2				
30	90387-0600V	COLLAR	2				
31	90201-06085	WASHER, PLATE	2				
32	90153-06034	SCREW, HEXAGON	2				
33	JB5-82590-00	WIRE HARNESS ASSY	1				
34	JN2-81980-01	.DIODE ASSY	1				
35	5JJ-82151-10	.FUSE (15A-BL)	2				
36	5JJ-82151-20	.FUSE (20A-BL)	3				
37	5JJ-82151-40	.FUSE (4A-BL)	3				
38	JR9-82151-00	.FUSE (40A)	1				
39	4FM-82151-00	.FUSE (30A)	1				
40	90465-13152	CLAMP	6				
41	90465-13275	CLAMP	5				
42	90465-12356	CLAMP	1				
43	JX4-82355-00	GROMMET	1				
44	JY8-82355-00	GROMMET	2				
45	JN3-83383-10	BUZZER	1				
46	JY8-82216-00	WIRE, HIGH VOLTAGE LEAD 6	2				
47	JY8-82215-00	WIRE, HIGH VOLTAGE LEAD 5	1				
48	JY8-82211-00	WIRE, LEAD	1				
49	JY8-82212-00	WIRE, HIGH VOLTAGE LEAD 2	1				
50	JY8-82213-00	WIRE, HIGH VOLTAGE LEAD 3	1				
51	JY8-82214-00	WIRE, HIGH VOLTAGE LEAD 4	1				
52	JY8-82224-10	WIRE, HIGH VOLTAGE MINUS LEAD2	1				
53	JY8-82223-10	WIRE, HIGH VOLTAGE PLUS LEAD 2	1				
54	90465-13152	CLAMP	2				

FIG. 23 ELECTRICAL 1



JB51400-P230

REF. NO.	PART NO.	DESCRIPTION	JB53			REMARKS
55	90447-25004	TUBE	1			
56	JY3-82221-00	WIRE, HIGH VOLTAGE PLUS LEAD 1	1			
57	JY8-82119-00	COVER, LEAD WIRE	6			
58	JX5-82372-00	SEAL, PLUG CAP	3			
59	JB3-82170-00	FUSE BOX ASSY	1			
60	97022-08025	.BOLT, HEXAGON	2			
61	95302-08700	.NUT, HEXAGON	2			
62	95022-06012	BOLT, FLANGE	2			
63	JB3-82151-00	FUSE	1			
64	92902-08200	WASHER	2			
65	95302-08600	NUT, HEXAGON	2			
66	JB3-82172-00	COVER, FUSE BOX	1			
67	JT1-83614-00	BRACKET	1			
68	98902-06014	SCREW, BIND	2			
69	JY8-82219-00	WIRE, HIGH VOLTAGE LEAD 9	1			
70	JY8-82217-00	WIRE, HIGH VOLTAGE LEAD 7	1			
71	90465-12356	CLAMP	2			
72	90464-50001	CLAMP	2			
73	JX6-82510-00	MAIN SWITCH ASSY	1			
74	J44-82511-00	.KEY, MAIN SWITCH	1			
75	JX3-8350C-00	ENERGY GAUGE ASSY	1			
76	JB2-81977-10	BULB, PILOT LIGHT (RED)	1			
77	97702-50014	SCREW, TAPPING	2			
78	JB3-82617-K0	SWITCH	1			

NUMERICAL INDEX

PART NO.	REF. NO.	PART NO.	REF. NO.	PART NO.	REF. NO.	PART NO.	REF. NO.	PART NO.	REF. NO.	PART NO.	REF. NO.
JB8-22110-00	1 - 1	JR7-2387F-00	4 - 16	JX3-25883-10	9 - 9	JB2-27229-00	9 - 26	JT2-77766-22	16 - 25	JB2-78243-00	15 - 2
JX4-22123-00	1 - 10	JR7-2387G-00	4 - 14	JX2-25885-11	9 - 34	JB2-27263-00	5 - 15	JY4-77768-10	13 - 16	JB2-78244-00	15 - 3
JX4-22124-00	1 - 3	JR7-2387J-00	4 - 17	JX2-25885-11	9 - 42	JB2-27275-00	8 - 2	JB2-78100-30	15 - 1	JX4-78273-00	15 - 29
JB2-22172-00	1 - 2	JR7-2387K-00	4 - 15	JB2-2588A-00	9 - 10	JB2-27411-00	15 - 17	JX4-78101-00	15 - 10	J50-78274-10	18 - 26
JY3-22210-00	1 - 7	JR7-23894-00	4 - 23	JB2-2588B-00	9 - 11	JY2-27801-01	10 - 1	JX4-78101-20	15 - 10	JX4-78297-01	20 - 45
5GJ-22426-00	2 - 20	8AC-2414B-01	15 - 11	JX2-2588C-10	9 - 12	JY2-28415-01	19 - 25	JX4-78101-30	15 - 10	JX5-78297-11	20 - 47
JB4-22501-09	2 - 1	JR7-2467K-00	4 - 21	JY2-2588D-00	9 - 13	JB8-46311-00	11 - 1	JX4-78101-60	15 - 10	JB2-78298-20	15 - 5
JY6-22504-00	2 - 10	JY2-2474E-00	19 - 26	JB2-2588E-00	9 - 14	JB8-46312-00	11 - 9	JY2-7810M-00	20 - 35	JB5-78299-00	18 - 10
JB8-22506-09	2 - 2	JY8-25100-30	3 - 24	JB2-2588H-00	9 - 5	JX3-46319-00	11 - 15	JY2-78113-00	15 - 15	JY2-7829A-20	13 - 29
JX4-2254R-01	16 - 13		12 - 14	JB2-2588J-00	9 - 6	JB3-46321-00	11 - 18	JB6-7811V-00	15 - 28	JY3-78305-00	16 - 18
JY8-2255A-00	2 - 4	JY8-2510S-20	3 - 27	JB2-25896-00	9 - 18	JB3-46351-00	11 - 19	JB3-78130-00	16 - 6	JB2-7830A-00	13 - 25
JY8-2255A-10	2 - 5		12 - 17	3JD-25917-00	6 - 7	JB3-78130-00	11 - 20	JB3-78130-20	16 - 6	JB2-7830B-00	13 - 27
JB2-22571-00	2 - 12	JY2-25110-00	3 - 28		6 - 21	JB3-46362-00	11 - 21	JB3-78130-30	16 - 6	JB2-7830C-00	18 - 28
JY8-22572-10	2 - 13	JY8-2512A-01	3 - 36		7 - 7	JB2-46411-00	11 - 25	JB3-78130-60	16 - 6	JB2-7830D-00	18 - 32
JY8-22592-00	2 - 7		12 - 21		7 - 21	JB2-46414-00	11 - 27	JB3-78139-00	15 - 25	JB3-7830E-00	18 - 16
JX4-22597-00	2 - 15	JY8-25180-00	3 - 25	JX2-25919-00	6 - 8	JB2-46415-00	11 - 28	JB2-7813F-00	13 - 26	JB3-7830E-10	18 - 18
JY1-2259H-00	2 - 8		12 - 15		6 - 22	JB2-46417-00	11 - 29	JB2-7813G-00	13 - 28	JB3-7830F-00	18 - 20
JY8-23350-01	3 - 18	JB2-25310-00	12 - 18		7 - 8	JB3-46421-00	11 - 26	JY3-7813H-00	16 - 15	JB3-7830F-10	18 - 22
JX4-23400-01	4 - 9	JX2-2580T-02	6 - 3		7 - 22	JY2-46511-00	12 - 9	JB3-78140-00	16 - 7	JB3-78314-00	18 - 1
JX4-23417-00	4 - 27		7 - 3	3JD-25926-00	6 - 12	JY2-46512-00	12 - 10	JB3-78140-20	16 - 7	JX4-7831L-00	13 - 31
JX4-23427-00	4 - 30	JX2-2580U-02	6 - 17		6 - 26	JX2-46540-00	12 - 1	JB3-78140-30	16 - 7	JB2-7831N-00	18 - 39
	4 - 36		7 - 17		7 - 12	JX2-46550-00	12 - 5	JB3-78140-60	16 - 7	JY2-7831W-00	19 - 54
JX4-23445-00	4 - 26	JB2-25816-00	9 - 19		7 - 26	JN3-47559-00	11 - 45	JB8-78141-00	16 - 1	JB2-78323-00	19 - 40
JX2-23510-00	3 - 21	JB2-2581J-00	9 - 4	1UY-25926-51	6 - 10	JX4-77157-00	15 - 14	JB8-78141-20	16 - 1	JY2-78328-20	15 - 8
JX2-23520-00	3 - 22	1UY-25824-51	6 - 9		6 - 24	JY3-77174-00	13 - 13	JB8-78141-30	16 - 1	JY3-78329-00	16 - 8
2HR-23526-00	3 - 2		6 - 23		7 - 10	JX4-77188-00	15 - 13	JB8-78141-60	16 - 1	JX4-7832F-00	18 - 2
	3 - 11		7 - 9		7 - 24	JB2-77201-02	13 - 1	JY2-78142-00	16 - 5	JX4-7832H-00	16 - 9
JB2-23540-00	3 - 1		7 - 23	3TB-25933-00	6 - 15	JB2-77202-02	13 - 15	JB2-78145-00	19 - 33	JX4-78334-01	18 - 41
JX4-23549-01	3 - 3	1UY-25825-51	6 - 16		6 - 29	JY2-77212-10	13 - 10	JX4-7814E-00	16 - 17	JX4-7833H-00	16 - 10
JY8-23570-01	3 - 10		6 - 30		7 - 15	JB2-77213-00	13 - 2	JX4-7814H-00	15 - 7	JB2-7833K-10	18 - 13
JX4-23579-01	3 - 12		7 - 16		7 - 29	JB2-77214-00	13 - 3	JY3-78150-10	16 - 14	JB2-78355-00	19 - 1
JY1-23810-00	4 - 1		7 - 30	1UY-25937-51	6 - 6	JX4-77217-00	13 - 6	J17-78157-01	19 - 4	JB2-78356-00	19 - 22
JX4-23812-00	4 - 12	JB2-25826-00	9 - 21		6 - 20	JY3-77223-00	13 - 8		19 - 9	JN5-78357-10	4 - 37
JR9-23823-01	4 - 28	JX2-2582A-00	9 - 35		7 - 6	JB2-77233-01	13 - 14	JX4-78164-00	14 - 2	JB2-78358-00	19 - 45
JR7-23833-00	4 - 24	JX2-2582T-00	6 - 1		7 - 20	JB2-77261-00	13 - 4	JX4-78165-00	14 - 3	JX4-78358-00	4 - 39
JX4-23837-00	4 - 20		7 - 1	1UY-25938-51	6 - 11	JB2-77262-00	13 - 5	JB2-78178-00	19 - 21	JX4-7835E-00	15 - 9
JN5-23838-00	4 - 3	JB2-2583T-00	9 - 16		6 - 25	JY3-77263-01	13 - 12	JB2-7817F-00	18 - 31	JB2-7835J-10	19 - 16
JX4-23841-00	4 - 25	JB2-25852-00	9 - 20		7 - 11	JB2-77271-00	13 - 18	JB2-7817G-00	18 - 35	JB8-78361-01	20 - 24
JR7-23844-00	4 - 18	2GU-25866-00	9 - 15		7 - 25	JB2-77275-00	13 - 19	JB2-78180-00	14 - 8	JB8-78362-01	20 - 15
JR7-23848-00	4 - 19	JB2-25871-00	9 - 7	JX2-25961-00	6 - 13	JB2-77283-00	13 - 17	JX2-78181-00	15 - 22	JX4-78364-00	19 - 23
JX4-2384N-00	4 - 11	JB2-25872-00	9 - 1		6 - 27	JB2-77510-00	14 - 1	JB2-78187-00	17 - 1	JF7-78367-00	19 - 2
J50-23857-00	4 - 2	JB2-25873-00	9 - 2		7 - 13	JX4-77520-00	14 - 6	JX4-7818E-00	14 - 9	J17-78368-01	19 - 5
JR7-23866-00	4 - 22	JB2-25874-00	9 - 3		7 - 27	JF7-77563-00	14 - 12	JX4-7818F-00	14 - 10		19 - 10
JB6-2386N-01	4 - 8	5KM-25875-00	9 - 37	JB2-26326-00	9 - 17	JB2-77711-00	15 - 19	JB2-78191-00	17 - 4	J17-78369-00	19 - 6
JX4-23876-00	4 - 29	JB2-25876-00	9 - 39	JB2-27200-00	5 - 1	JB5-77741-00	15 - 20	JB2-78192-00	17 - 5		19 - 11
	4 - 35	JX2-2587A-00	9 - 43	JB2-27211-00	5 - 3	JB9-77742-00	15 - 24	JF7-78214-00	18 - 25	JY2-78369-00	19 - 51
JX4-2387A-01	4 - 10	JB2-25880-00	9 - 22	JB2-27218-00	9 - 23	JY6-77762-10	4 - 38	JB8-78231-00	16 - 21	JX4-7836H-00	19 - 20
JX4-2387E-00	4 - 13	JX2-25882-10	9 - 8	JB2-27222-00	9 - 24	JY8-77765-21	20 - 46	JB8-78241-00	16 - 23	JX7-7836H-00	18 - 14

NUMERICAL INDEX

PART NO.	REF. NO.	PART NO.	REF. NO.	PART NO.	REF. NO.	PART NO.	REF. NO.	PART NO.	REF. NO.	PART NO.	REF. NO.
JB8-7836L-01	20 - 16	JY8-81890-02	21 - 1	JX3-8350C-00	23 - 75	90116-10405	23 - 20	90201-120T5	19 - 36	90462-08007	11 - 35
JY2-78374-00	19 - 42	JT2-81950-01	23 - 26	JT1-83614-00	23 - 67	90149-08291	20 - 20	90201-12190	4 - 5	90464-04002	9 - 33
JB2-78375-00	19 - 28	JY3-81962-10	22 - 14	JT1-83614-00	11 - 44	90150-06015	22 - 5	90201-12195	11 - 38	90464-16021	10 - 7
JB2-78376-00	19 - 29	JB2-81977-10	23 - 76	JY8-83688-10	23 - 9	90153-06034	23 - 32	90201-121J0	1 - 6	90464-50001	23 - 72
JB2-78380-00	19 - 49	JN2-81980-01	23 - 34	JN9-85885-00	10 - 2	90157-06011	19 - 14	90201-122H1	19 - 35	90465-12356	23 - 42
JB2-78389-00	19 - 43	JY8-82119-00	23 - 57	JB2-85930-09	8 - 1	90157-06068	18 - 27	90201-163M0	3 - 33		23 - 71
JB2-78392-00	18 - 8	JY8-82122-01	23 - 10	JY3-86182-00	22 - 4	90159-06055	19 - 3	90201-20032	11 - 22	90465-13152	17 - 2
JB2-78393-00	18 - 11	JT2-82123-00	23 - 3	JB2-86281-00	11 - 33	90171-12001	3 - 14	90201-20033	11 - 23		23 - 40
JR7-78402-01	20 - 32	JB8-82129-00	23 - 24	JX3-86290-00	11 - 37		4 - 33	90206-38001	21 - 20		23 - 54
JB8-78404-00	20 - 6	J17-82133-00	23 - 16	JY3-86514-00	22 - 10	90179-06020	13 - 22	90267-48101	2 - 14	90465-13275	17 - 3
JB8-78405-00	20 - 2	JH2-82133-00	23 - 5	JY3-87214-00	22 - 3	90179-06021	18 - 17		17 - 6		23 - 41
JB8-78407-00	20 - 27	JY8-82133-00	23 - 17	JT2-88109-20	22 - 12		18 - 19	90269-05055	19 - 24	90468-08104	23 - 12
JB8-78410-10	20 - 1	JY8-82136-00	23 - 13	JB5-8A210-00	22 - 1		18 - 21	90269-06003	18 - 38	90480-08216	19 - 44
JB6-78413-00	20 - 30	JY3-8213F-00	23 - 4	JX2-W0045-11	6 - 14		18 - 23	90269-07010	16 - 4	90480-13398	15 - 12
JB8-78418-00	20 - 28	JY8-8213F-00	23 - 14		7 - 14	90179-06059	18 - 30		16 - 20	90480-13567	15 - 21
JB8-78420-00	20 - 5	4FM-82151-00	23 - 39	JX2-W0045-21	6 - 28		18 - 34	90269-07064	15 - 4	90480-16278	23 - 29
JB8-78423-00	20 - 14	JB3-82151-00	23 - 63		7 - 28	90179-06636	18 - 9		16 - 22	90480-25004	18 - 7
JR7-78426-00	20 - 9	JR9-82151-00	23 - 38	3GD-W0047-00	6 - 5		18 - 12		16 - 24	90502-10013	4 - 42
JX4-78427-00	16 - 11	5JJ-82151-10	23 - 35		6 - 19	90179-08491	11 - 47	90269-07077	23 - 25	90506-10001	19 - 53
JY2-78427-00	16 - 2	5JJ-82151-20	23 - 36		7 - 5	90179-08689	18 - 29	90269-10005	15 - 6	90508-40015	5 - 8
JX4-7842F-00	20 - 41	5JJ-82151-40	23 - 37		7 - 19		18 - 33		15 - 16	91317-08045	11 - 43
JX4-7842G-00	20 - 42	JB3-82170-00	23 - 59	3TB-W0057-00	6 - 4	90179-10031	3 - 32		15 - 18	91402-25020	3 - 7
JF7-78433-00	20 - 3	JB3-82172-00	23 - 66		6 - 18		12 - 20		15 - 23		3 - 15
	20 - 7	JY8-82211-00	23 - 48		7 - 4	90179-20016	12 - 11		16 - 16		3 - 35
JB2-78439-00	20 - 13	JY8-82212-00	23 - 49		7 - 18	90185-06153	23 - 6		16 - 19		4 - 34
JB8-78460-00	2 - 17	JY8-82213-00	23 - 50	90101-10038	12 - 12	90185-10019	5 - 10		17 - 7	91490-25020	9 - 28
JY2-78478-00	20 - 38	JY8-82214-00	23 - 51	90105-05331	10 - 3	90185-12009	1 - 5	90338-08174	21 - 24	91609-40040	11 - 32
JY2-78483-30	19 - 47	JY8-82215-00	23 - 47	90105-06452	11 - 42	90201-044H9	4 - 41	90338-15004	19 - 48	91690-20020	13 - 9
JY2-78484-00	20 - 33	JY8-82216-00	23 - 46	90105-08096	20 - 17	90201-06020	13 - 21	90338-24204	18 - 40	91690-30012	13 - 11
JY8-81129-00	21 - 16	JY8-82217-00	23 - 70	90105-08198	20 - 22		20 - 37	90340-14036	11 - 16	92902-08100	9 - 25
JT2-81135-00	21 - 7	JY8-82219-00	23 - 69	90105-08252	20 - 25	90201-06049	20 - 40	90381-18004	19 - 30	92902-08200	20 - 12
JT2-81150-00	21 - 2	JY3-82221-00	23 - 56	90105-10116	3 - 8		20 - 44	90384-14080	5 - 2		20 - 19
JT2-81152-00	21 - 5	JY8-82223-10	23 - 53	90105-10221	3 - 16	90201-06072	23 - 7	90386-06108	19 - 7		23 - 64
JT2-81157-00	21 - 3	JY8-82224-10	23 - 52	90105-10283	4 - 31	90201-06085	23 - 31		19 - 12	93102-20143	11 - 12
JX3-81160-00	21 - 4	JX2-8234W-01	11 - 40	90105-102A9	6 - 31	90201-06090	23 - 15	90387-046N7	4 - 43	93102-25017	11 - 5
JT2-81218-00	21 - 15	JY8-82353-00	23 - 11		7 - 31	90201-06106	19 - 15	90387-0600V	23 - 30	93102-25360	11 - 6
JT2-81252-00	21 - 8	JX4-82355-00	23 - 43	90105-10348	11 - 30	90201-06115	18 - 4	90387-06553	13 - 20		11 - 13
JT2-81352-00	21 - 10	JY8-82355-00	23 - 44	90105-10728	3 - 5	90201-06116	18 - 5	90387-08031	19 - 19	93102-35109	12 - 3
JT2-81353-00	21 - 18	JX5-82372-00	23 - 58	90105-12031	1 - 11	90201-08026	20 - 21	90387-10109	5 - 12		12 - 7
JY8-81411-00	23 - 22	JX6-82510-00	23 - 73	90109-06302	9 - 44	90201-08088	9 - 27	90387-12053	19 - 31	93210-132A8	5 - 11
JT2-81452-00	21 - 12	J44-82511-00	23 - 74	90109-08221	6 - 2	90201-08101	19 - 39	90387-15019	18 - 6	93305-00602	3 - 29
JT2-81552-00	21 - 17	JY3-82519-00	11 - 36		7 - 2	90201-08730	18 - 36	90387-252M8	11 - 24	93306-00803	11 - 4
JT2-81652-00	21 - 13	JB2-82530-00	5 - 13	90109-10473	19 - 32		20 - 18	90387-30006	3 - 23		11 - 11
5GM-81677-00	9 - 32	JB5-82590-00	23 - 33	90110-06091	11 - 34		20 - 26	90401-10015	9 - 30	93306-20401	11 - 3
JT2-81811-00	21 - 14	JB3-82617-K0	23 - 78	90111-08013	19 - 34	90201-10028	23 - 18	90430-14043	11 - 17		11 - 10
JX3-81822-00	21 - 9	JF7-82817-22	10 - 4	90111-08027	14 - 11	90201-10118	9 - 31	90447-25004	23 - 55	93306-20501	11 - 2
JX3-81823-00	21 - 21	JT2-83325-00	21 - 6	90114-10019	3 - 31	90201-102J5	19 - 38	90462-05059	15 - 27	93306-30578	12 - 2
JT2-8184J-00	21 - 11	JN3-83383-10	23 - 45		12 - 19	90201-105A2	4 - 32	90462-06007	22 - 2		12 - 6

NUMERICAL INDEX

PART NO.	REF. NO.	PART NO.	REF. NO.	PART NO.	REF. NO.	PART NO.	REF. NO.	PART NO.	REF. NO.	PART NO.	REF. NO.
93900-00022	3 - 26	95812-06010	8 - 3	97707-30110	22 - 11						
	12 - 16	95812-06050	21 - 19	97707-40525	4 - 40						
95022-06012	9 - 36	95812-08012	8 - 4	97707-40525	22 - 13						
	22 - 7	95812-08020	2 - 16	98780-06014	13 - 7						
	23 - 62		4 - 7	98780-06035	13 - 23						
95022-08025	14 - 7	95812-08025	9 - 29	98902-06014	23 - 68						
95024-06016	19 - 41	95812-08035	21 - 23	98980-06012	20 - 31						
95302-08600	23 - 65	95812-08055	13 - 30	99009-30400	3 - 4						
95302-08700	23 - 61		18 - 37	99009-32400	3 - 13						
95307-08800	19 - 27	95812-08060	19 - 17	99009-55500	3 - 30						
95307-10800	19 - 37	95812-08075	11 - 46	99009-62500	12 - 4						
95380-08600	19 - 52	95812-10016	1 - 13		12 - 8						
95602-06200	2 - 21	95812-10030	12 - 13	99080-05600	19 - 8						
	22 - 6	95812-10045	1 - 8		19 - 13						
95602-08200	19 - 18	95812-10090	5 - 9	99530-12016	11 - 14						
	20 - 23	95812-12065	1 - 4	99530-14016	11 - 31						
95602-10200	1 - 9	95822-06012	14 - 4								
	3 - 17	95822-06016	2 - 9								
	3 - 20		22 - 9								
95602-12100	4 - 4	95822-06030	5 - 4								
95602-12200	1 - 12	95822-08014	5 - 16								
	11 - 39		21 - 22								
95604-16200	3 - 34	95822-08016	2 - 3								
95607-10200	3 - 9		2 - 6								
95702-06500	5 - 5	95822-08020	23 - 23								
	23 - 19	95822-08040	11 - 7								
95702-08500	4 - 6	95822-08050	11 - 8								
	5 - 7	95822-10025	2 - 11								
	5 - 14	95822-10045	3 - 19								
	5 - 17	95827-08065	14 - 5								
	23 - 27	95880-06012	19 - 50								
95702-10500	3 - 6		19 - 55								
	23 - 21	95880-06016	18 - 15								
95802-06010	11 - 41	95880-06020	18 - 24								
95802-06012	2 - 18		20 - 36								
	9 - 38	95880-06025	13 - 24								
	9 - 40	95880-06030	18 - 3								
	10 - 6	95880-08025	20 - 34								
95802-06016	20 - 29	97022-05012	22 - 8								
95802-06020	23 - 28	97022-06025	20 - 10								
95802-06025	9 - 41	97022-08025	23 - 60								
95802-06030	2 - 19	97080-06016	20 - 43								
	16 - 3	97080-06020	20 - 39								
95802-06040	16 - 12	97507-05512	10 - 5								
95802-08012	19 - 46	97702-50014	15 - 26								
95802-08014	23 - 1		23 - 77								
95802-08035	5 - 6	97702-50016	20 - 4								
95807-06020	20 - 11		20 - 8								