



# PARTS CATALOGUE

## DR2E17T 6-PASS ( J1E1 ) OTHERS

---



1SJ1E-400E1

( )

DR2E17T 6-PASS  
PARTS CATALOGUE  
©2017 by Yamaha Motor Co., Ltd.  
1st edition, September 2017  
All rights reserved.  
Any reprinting or unauthorized use  
without the written permission of  
Yamaha Motor Co., Ltd.  
is expressly prohibited.  
Printed in Japan.

# FOREWORD

This Parts Catalogue is related to the parts for the model(s) on the cover page. When you are ordering replacement parts, please refer to this Parts Catalogue and quote both part numbers and part names correctly.

1. Modifications or additions which have been made after the issue of the Parts Catalogue will be announced in the Parts News.  
It is advisable that you make the necessary corrections to the Parts Catalogue according to the Parts News.
2. Abbreviations  
The following abbreviations are used in this Parts Catalogue.  
“UR” Use specified parts number.  
“UN” Use as many as needed.  
“AP” Alternate Parts  
“LM” Locally Made (Parts need to be ordered locally)  
“F#” Frame No. (Applicable machine No.)  
“O/S” Over Size
3. The number of components for assembly
  - Parts, which are to be supplied in an assembly, are listed with a dot (.) in front of the part name as shown below.
  - The numeral appearing to the right of each component part indicates the quantity of parts for each assembly unit.

PART NO.	DESCRIPTION	Q'TY	REMARKS
2F5-83310-60	FRONT FLASHER LIGHT ASSY	2	
115-83311-60	.BULB (6V-18W)	1	

4. Applicable colours of graphics are represented in the “REMARKS” as shown below.

PART NO.	DESCRIPTION	Q'TY	REMARKS
2N4-24110-00-X5	FUEL TANK COMP.	2	MXR
3J1-24240-10	.GRAPHIC, FUEL TANK	1	FOR MXR

5. Note that the illustrations for reference in finding parts numbers are not to be used for assembling. When assembling, please use the applicable service manual.

6. The asterisk (\*) before a reference number indicates modified items after the first edition.

# FOREWORD

7. Applicable Serial No.

Frame Serial No.

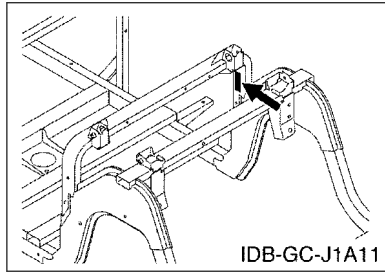

8. Applicable Colour Code (The (\*) mark shows Model colour.)

Abbreviation	Colour Name	Colour Code
BW1(*)	BLUISH WHITE 1	1571

9. Quantity Column Information

Column No.	Name Of Q'ty Column	Destination
1	J1E1	OTHERS

10. Applicable Starting Serial No.

Frame Serial No.

Serial No.	Name Of Q'ty Column	Model Code
J1E-101001	J1E1	J1E1

# CONTENTS

## BODY

REAR ARM & SUSPENSION.....	1
FRAME.....	2
FRONT SUSPENSION.....	4
STEERING.....	6
PEDAL WIRE.....	8
PEDAL ASSEMBLY.....	9
BRAKE.....	12

## DRIVE

TRANSAXLE.....	13
WHEEL.....	15

## R/G

WINDSHIELD.....	16
BUMPER.....	17
BODY.....	18
BODY 2.....	19
BODY 3.....	20
BODY FITTING.....	21
SUN ROOF.....	22
CARRIER.....	23
SEAT.....	24

## ELECTRICAL

ELECTRIC MOTOR.....	26
CONTROLLER 1.....	28
ELECTRICAL 1.....	29
BATTERY CHARGER.....	31

## INDEX

NUMERICAL INDEX.....	32
----------------------	----

**FIG. 1 REAR ARM & SUSPENSION**

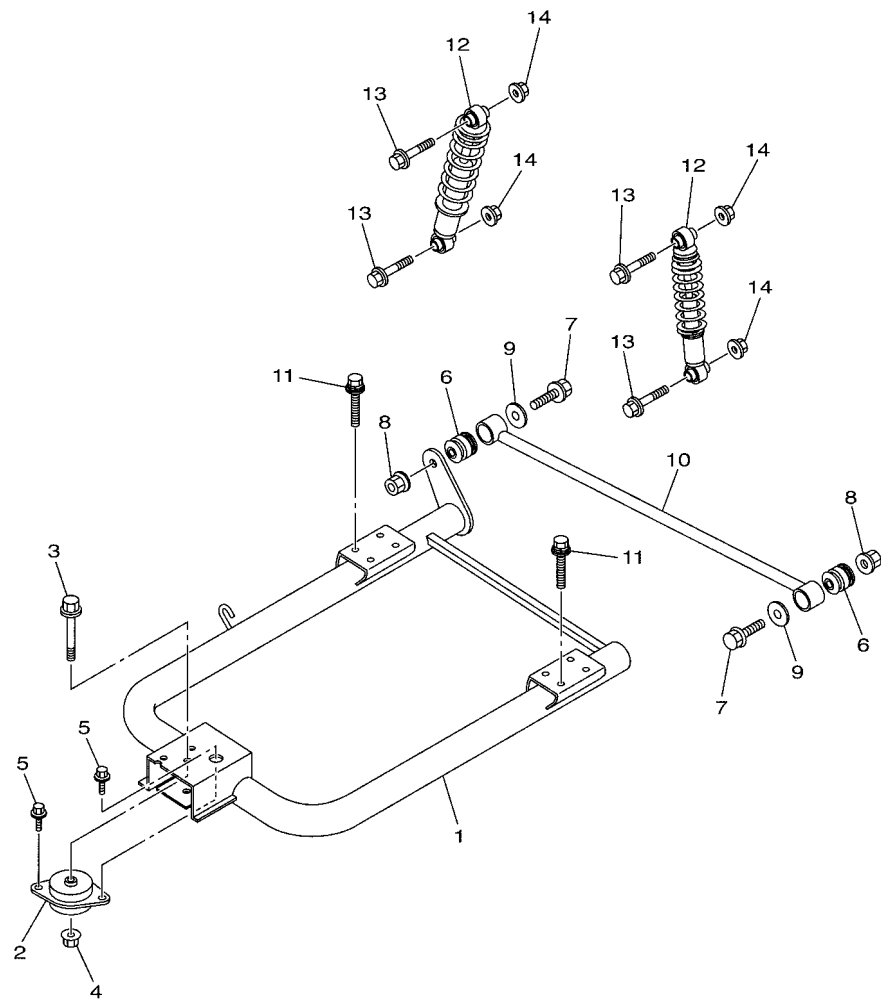

REF. NO.	PART NO.	DESCRIPTION	JTEI				REMARKS
1	J1B-F2110-00	REAR ARM COMP.	1				
2	JX4-22123-00	BUSH 1	1				
3	90105-12031	BOLT, FLANGE	1				
4	95602-12200	NUT, SELF-LOCKING	1				
5	95812-10016	BOLT, FLANGE	2				
6	JN6-F2124-10	BUSH 2	2				
7	95812-12065	BOLT, FLANGE	2				
8	95602-12200	NUT, SELF-LOCKING	2				
9	90201-12426	WASHER, PLATE	2				
10	J1A-F217G-00	ROD, CONNECTING 2	1				
11	97512-10620	BOLT, WITH WASHER	8				
12	J1E-F2210-00	SHOCK ABSORBER ASSY, REAR	2				
13	95812-10055	BOLT, FLANGE	4				
14	95602-10200	NUT, S/L FLANGE	4				



J1B1400-S010

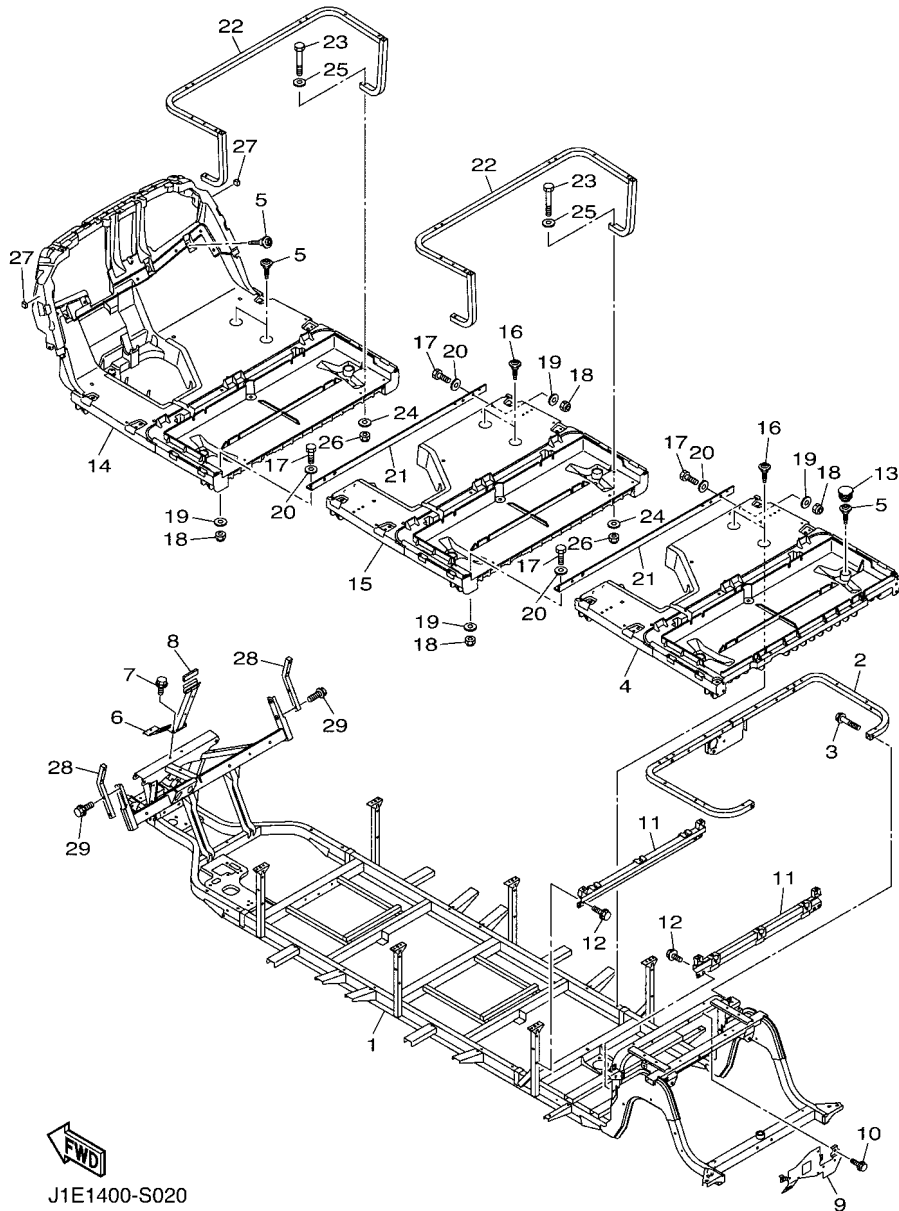

J1E1400-S020

FIG. 2 FRAME

REF. NO.	PART NO.	DESCRIPTION	J1E1				REMARKS
1	J1E-F2501-00	FRAME COMP.	1				
2	J1B-F255G-00	MEMBER, SEAT SUPPORT	1				
3	95812-08040	BOLT, FLANGE	2				
4	J1E-F7411-20	FOOTREST 1	1				
5	J0B-F1738-00	BOLT	9				
6	J1B-F258E-00	SUPPORT, FRONT COWL	1				
7	95822-08016	BOLT, FLANGE	2				
8	J1B-F2127-00	SHIM	1				
9	J1A-F252M-00	BRACKET, 3	1				
10	95822-06016	BOLT, FLANGE	3				
11	J1A-F2535-01	STAY, BATTERY 1	2				
12	95822-08016	BOLT, FLANGE	4				
13	JW9-F2417-00	PLUG	2				
14	J1E-F7411-00	FOOTREST 1	1				
15	J1E-F7411-10	FOOTREST 1	1				
16	J0B-F1738-00	BOLT	8				
17	97027-06025	BOLT, HEXAGON	16				
18	95680-06100	NUT, U	16				
19	90201-06020	WASHER, PLATE	16				
20	92990-06200	WASHER, PLAIN	16				
21	J1E-F7452-00	BRACKET, FOOTREST 1	2				
22	J1E-F255G-00	MEMBER, SEAT SUPPORT	2				
23	97027-06050	BOLT, HEXAGON	4				
24	90201-06020	WASHER, PLATE	4				
25	92990-06200	WASHER, PLAIN	4				
26	95680-06100	NUT, U	4				
27	J1B-K821A-00	PAD, BODY MOUNTING1	2				

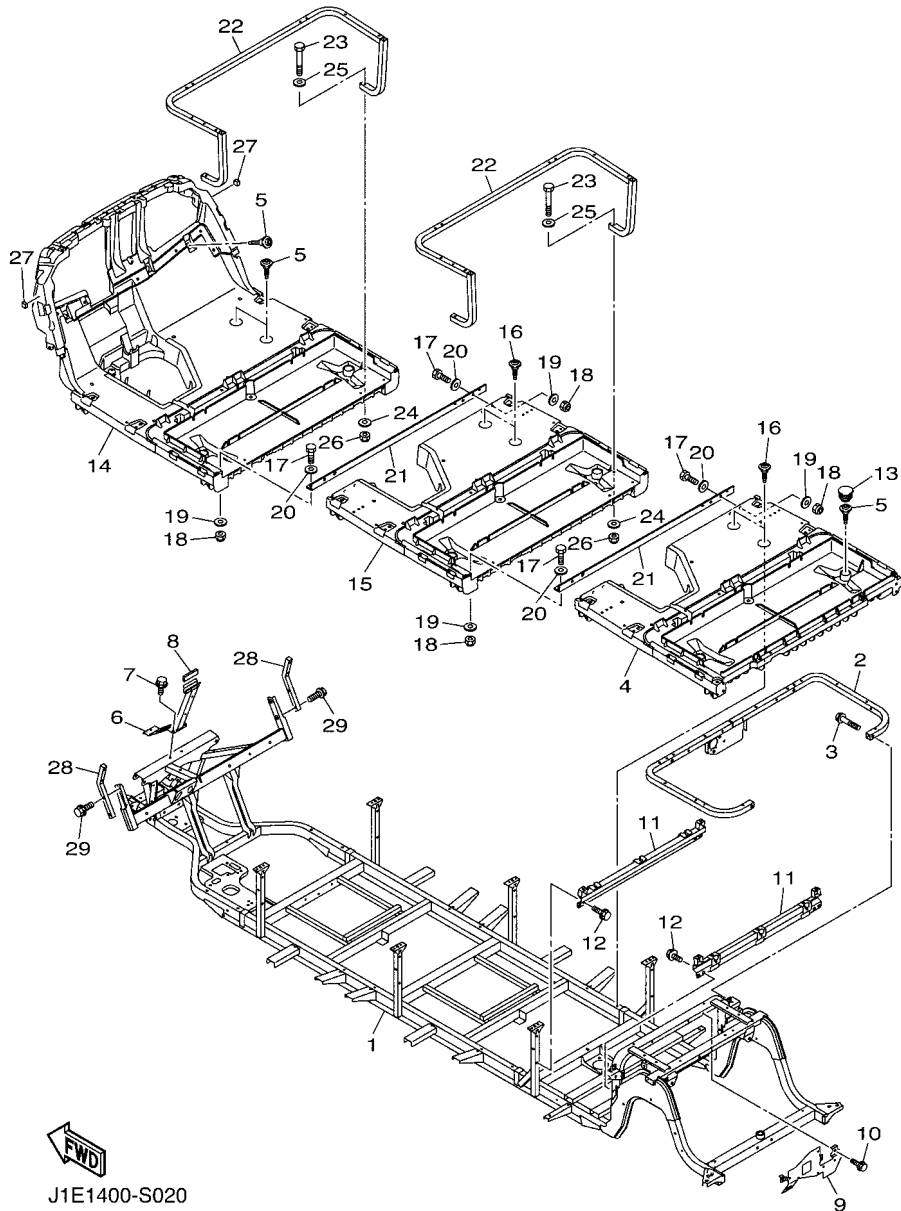
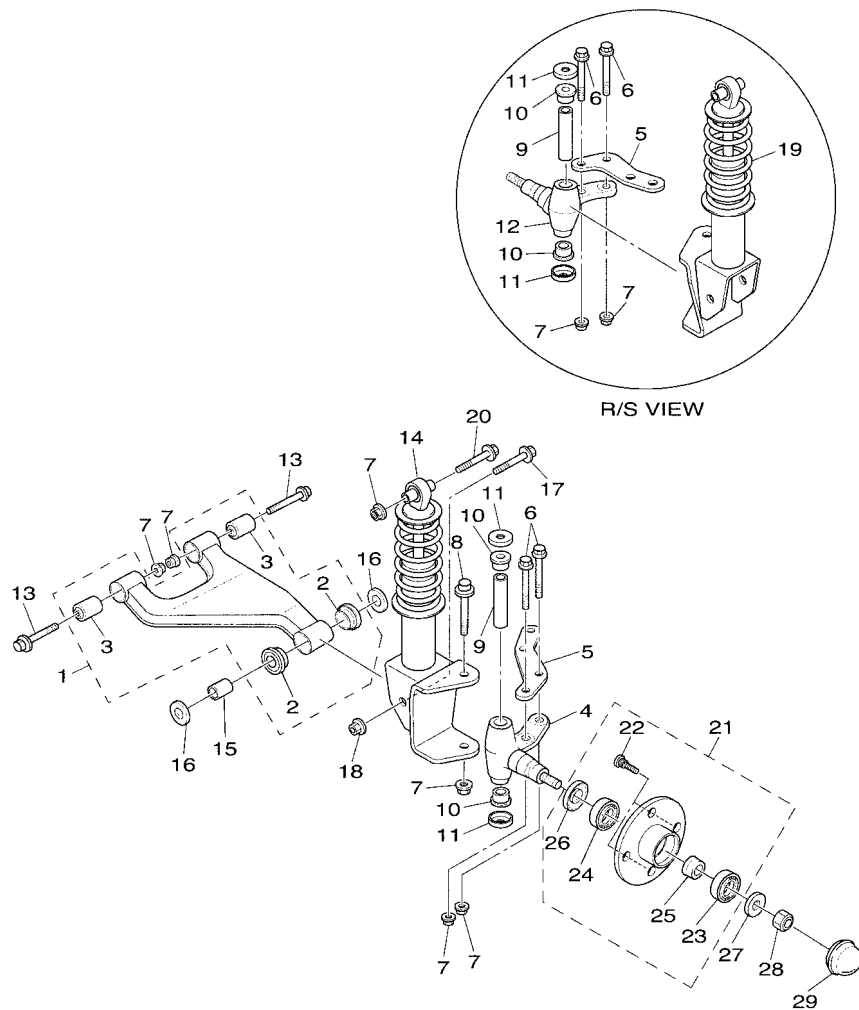

**FIG. 2 FRAME**

REF. NO.	PART NO.	DESCRIPTION	J1E1				REMARKS
28	J1B-K816M-00	REAR STORAGE BOX COMP.	2				
29	95D32-08030	BOLT, FLANGE DEEP RECESS	4				



**FIG. 3 FRONT SUSPENSION**



J1B1400-S030

REF. NO.	PART NO.	DESCRIPTION	JTEI				REMARKS
1	JU0-F3570-20	FRONT LOWER ARM COMP.	2				
2	90381-18001	.BUSH, SOLID	2				
3	2HR-23526-00	.BUSH	2				
4	JU0-F3511-10	KNUCKLE, STEERING 1	1				
5	JW1-F3512-00	ARM, KNUCKLE 1	2				
6	90105-10373	BOLT, FLANGE	4				
7	95602-10200	NUT, S/L FLANGE	12				
8	90105-10219	BOLT, FLANGE	2				
9	2NL-23448-00	SPACER	2				
10	90381-17800	BUSH, SOLID	4				
11	2NL-23517-00	COVER, THRUST 1	4				
12	JU0-F3521-10	KNUCKLE, STEERING 2	1				
13	90105-10267	BOLT, FLANGE	4				
14	J0C-F3350-00	SHOCK ABSORBER ASSY	1				
15	90387-12016	COLLAR	2				
16	J1A-F2128-00	COVER, THRUST 1	4				
17	95812-12080	BOLT, FLANGE	2				
18	95612-12100	NUT, U	2				
19	J0C-F3390-00	SHOCK ABSORBER ASSY 2	1				
20	90105-10267	BOLT, FLANGE	2				
21	JC1-F5103-00	HUB BEARING UNIT ASSY	2				
22	90114-12004	.BOLT, SERRATION	4				
23	93306-20437	.BEARING	1				
24	93306-005Y3	.BEARING	1				
25	90387-241M7	.COLLAR	1				
26	93102-30803	.OIL SEAL	1				
27	90209-32271	WASHER	2				

**FIG. 3 FRONT SUSPENSION**

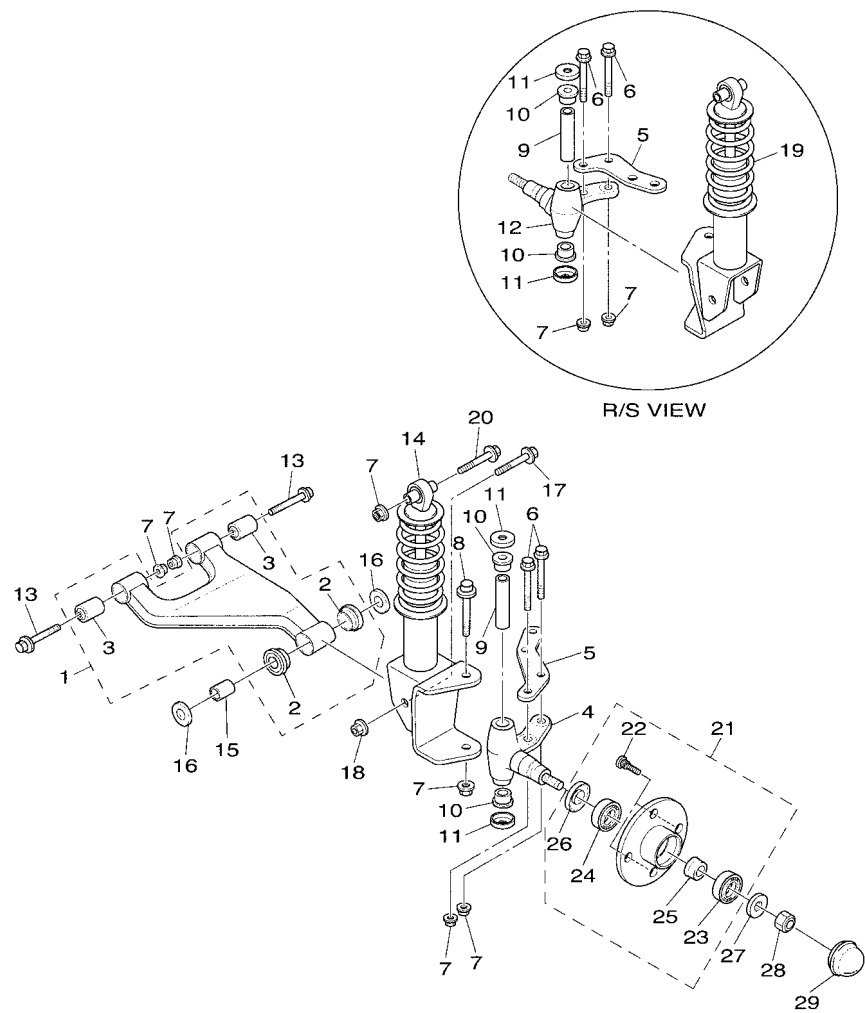

REF. NO.	PART NO.	DESCRIPTION	JTEI				REMARKS
28	95602-14100	NUT, U	2				
29	JN6-F5118-01	COVER, HUB DUST	2				

**FWD**  
 J1B1400-S030

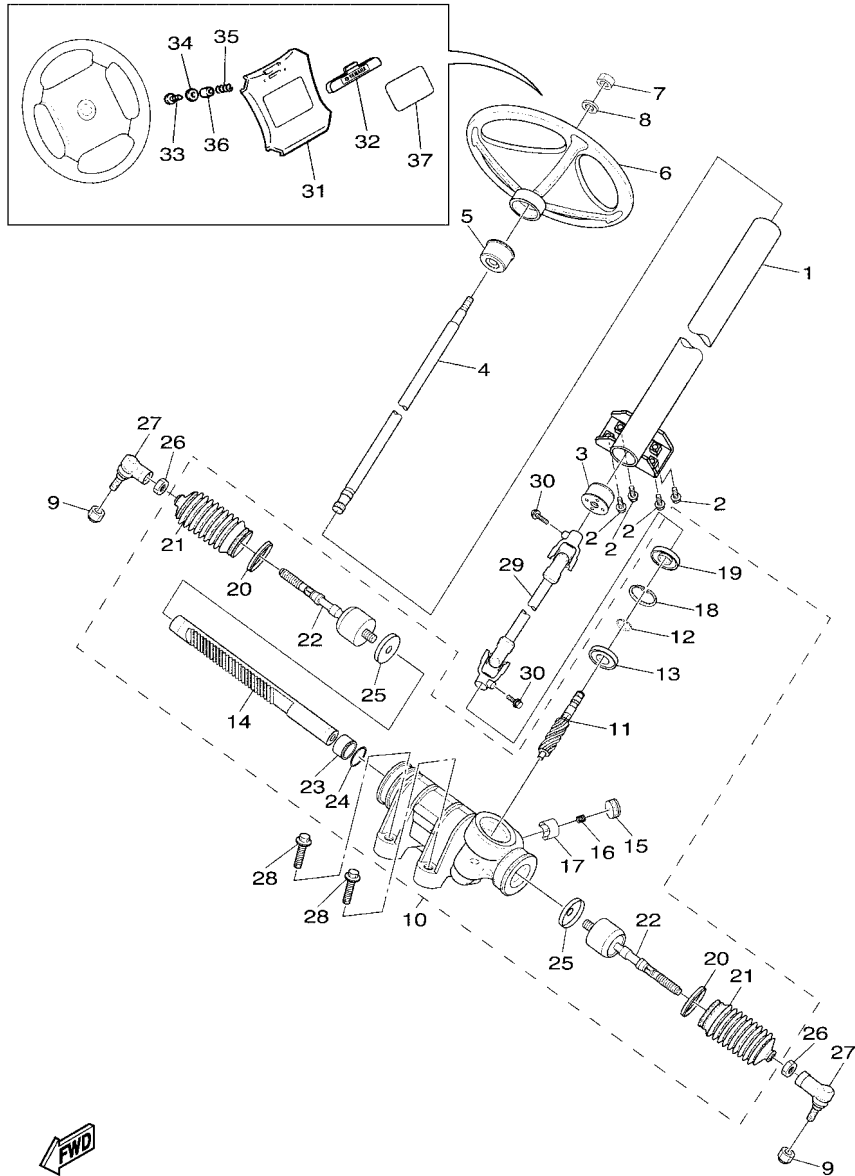

J1A1400-R040

FIG. 4 STEERING

REF. NO.	PART NO.	DESCRIPTION	JTEI				REMARKS
1	JW1-F3811-03	COLUMN, STEERING	1				
2	95812-08020	BOLT, FLANGE	4				
3	JU0-F3857-11	HOLDER	1				
4	JU0-F3828-10	ROD, STEERING	1				
5	JU0-F3857-11	HOLDER	1				
6	JN3-F3838-00	WHEEL, STEERING	1				
7	90185-12008	NUT, SELF-LOCKING	1				
8	92902-12200	WASHER	1				
9	95602-12200	NUT, SELF-LOCKING	2				
10	J1A-23400-00	STEERING ASSY	1				
11	J1A-2387A-00	.GEAR, PINION	1				
12	JX4-2384N-00	.CLIP, RING	1				
13	JX4-23812-00	.BEARING, STEERING	1				
14	J1A-2387E-00	.GEAR, RACK	1				
15	JR7-2387G-00	.COVER, ADJUST	1				
16	JR7-2387K-00	.SPRING, PRESSURE	1				
17	JR7-2387F-00	.PAD, PRESSURE	1				
18	JR7-2387J-00	.RING, STOPPER	1				
19	JR7-23844-00	.SEAL	1				
20	J1A-23489-00	.BAND	2				
21	J1A-23527-00	.SEAL, DUST 1	2				
22	J1A-23837-00	.ROD, TIE 2	2				
23	JR7-2467K-00	.BUSH CAP	1				
24	JR7-23866-00	.RING, SNAP	1				
25	JR7-23894-00	.WASHER, LOCK 1	2				
26	1P0-F3833-00	NUT 1	2				
27	J1A-F3841-00	JOINT, UNIVERSAL 1	2				

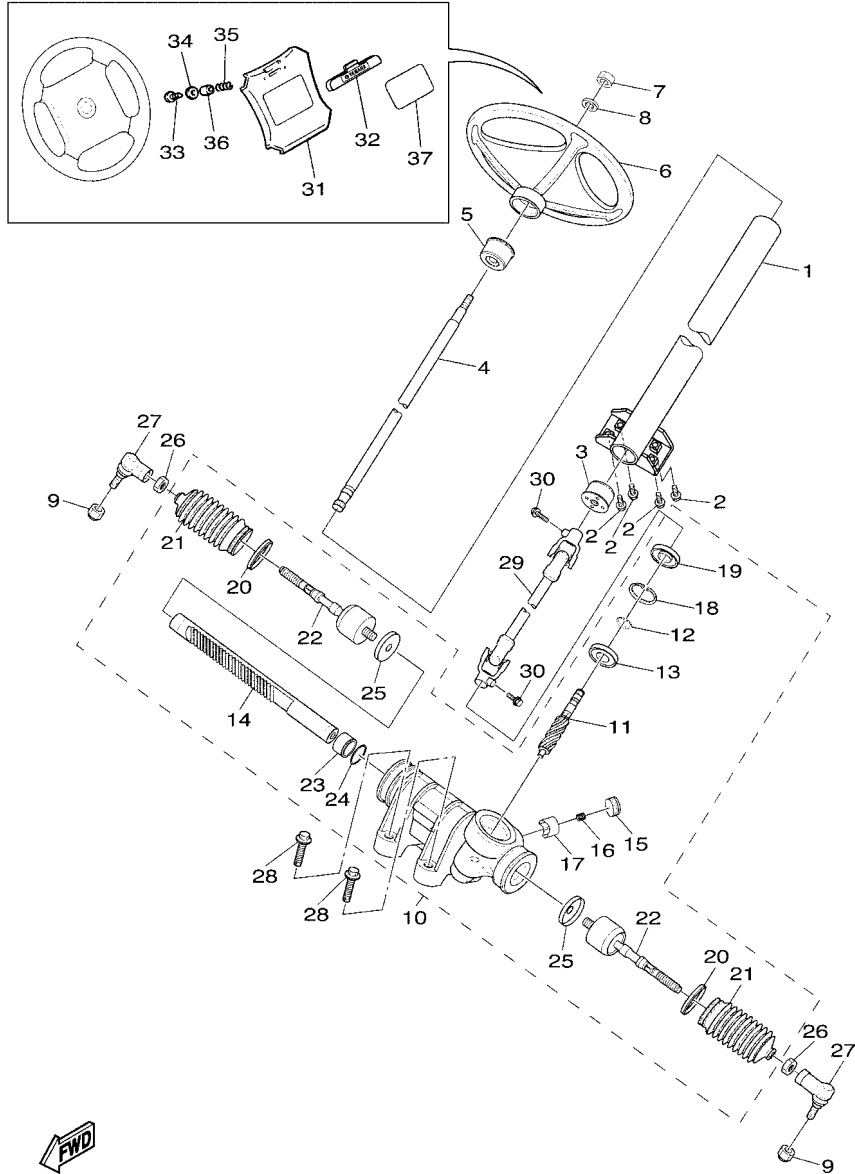

J1A1400-R040

FIG. 4 STEERING

REF. NO.	PART NO.	DESCRIPTION	JTEI					REMARKS
28	95812-10040	BOLT, FLANGE	4					
29	J1A-23822-00	JOINT 1	1					
30	97512-08530	BOLT, WITH WASHER	2					
31	JW8-K8357-00	HOLDER 1	1					
32	JN6-K8358-01	HOLDER 2	1					
33	97702-40525	SCREW, TAPPING	2					
34	90201-044H9	WASHER, PLATE	2					
35	90502-10013	SPRING, CONICAL	2					
36	90387-046N7	COLLAR	2					
37	JW8-K7762-00	LABEL, WARNING 2	1					

**FIG. 5 PEDAL WIRE**

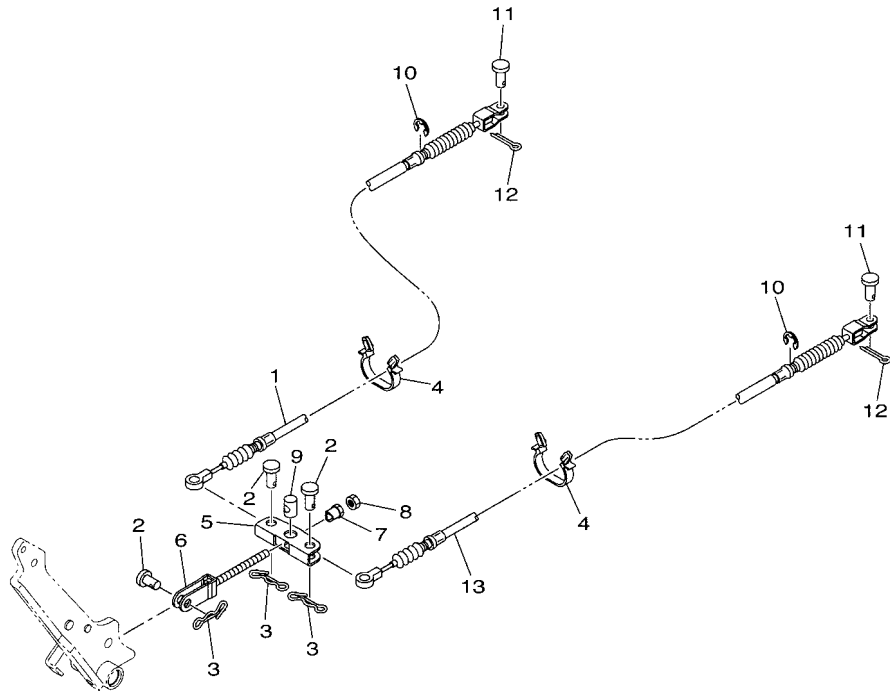

REF. NO.	PART NO.	DESCRIPTION	J1E1				REMARKS
1	J1E-F6351-00	CABLE, BRAKE	1				
2	91702-10026	PIN, CLEVIS	3				
3	90468-20196	CLIP	3				
4	90464-24230	CLAMP	4				
5	JW8-F5681-10	EQUALIZER, BRAKE	1				
6	JN6-F5685-01	ROD	1				
7	90179-08261	NUT	1				
8	95307-08700	NUT	1				
9	90249-14129	PIN	1				
10	99002-09600	CIRCLIP	2				
11	91702-08018	PIN, CLEVIS	2				
12	91490-25015	PIN, COTTER	2				
13	J1E-F6341-00	WIRE, BRAKE 1	1				



J1E1400-S050

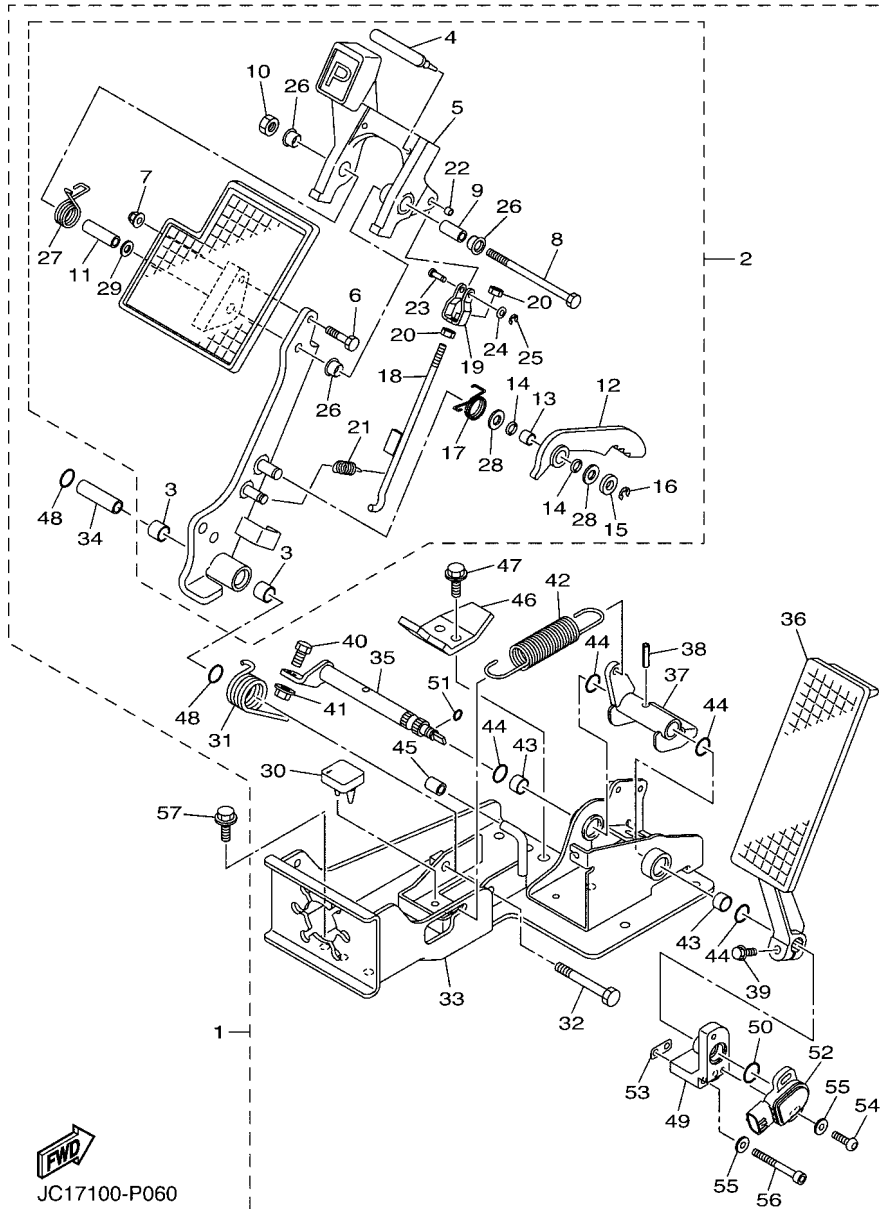

**FIG. 6 PEDAL ASSEMBLY**

REF. NO.	PART NO.	DESCRIPTION	JTEI	REMARKS
1	JW9-F7850-31	PEDAL ASSY (L.H)	1	
2	JW9-F7200-21	.PEDAL, BRAKE	1	
3	JW8-F7814-21	.BUSH, PEDAL	2	
4	JW9-F5672-00	..PAD, PARKING PEDAL	1	
5	JW9-F5671-00	..PEDAL, PARKING BRAKE	1	
6	JW8-F7117-00	..BOLT, MAIN STAND	1	
7	JW8-F8363-00	..NUT	1	
8	JW8-F7416-00	..BOLT, FOOTREST	1	
9	JW8-F639N-00	..COLLAR	1	
10	JW8-F7218-00	..NUT	1	
11	JW8-F7113-00	..COLLAR, MAIN STAND	1	
12	JW9-F5666-00	..SECTOR, PARKING BRAKE	1	
13	JW8-F7121-00	..BUSH	1	
14	JW9-F7221-00	..SEAL, SHAFT	2	
15	JW8-F7322-00	..WASHER	1	
16	JW8-F3183-00	..CIRCLIP	1	
17	JW8-F7426-01	..SPRING, RETURN	1	
18	JW9-F7231-10	..ROD, BRAKE	1	
19	JW9-F7232-00	..END, ROD 2	1	
20	JW8-F7318-00	..NUT	2	
21	JW8-F6314-00	..SPRING	1	
22	JW8-F639L-00	..BUSH 1	1	
23	JW9-F7228-00	..PIN, JOINT	1	
24	JW8-F8323-00	..WASHER, LEG SHIELD	1	
25	JW8-F5415-00	..CIRCLIP	1	
26	90386-12800	..BUSH	3	
27	JW8-F7825-01	..SPRING, RETURN	1	

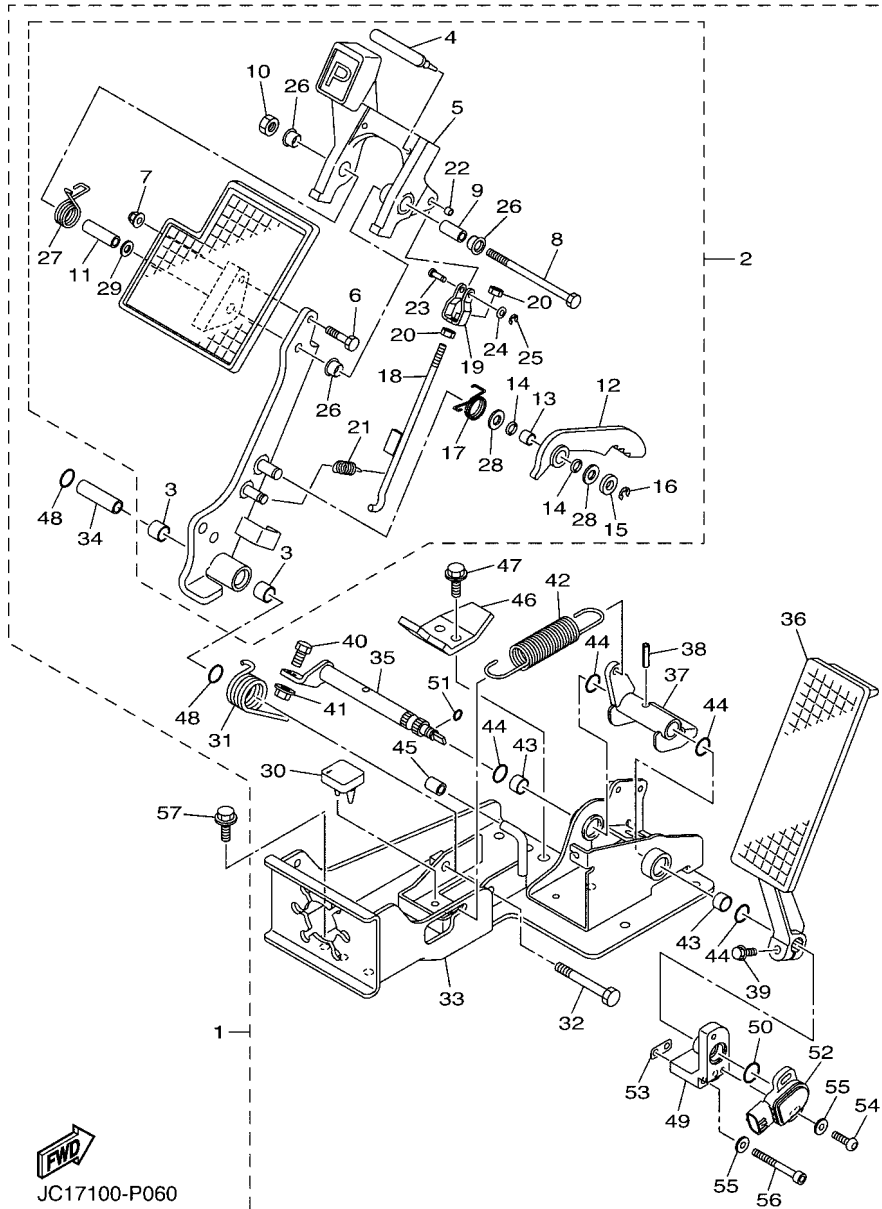

JC17100-P060

FIG. 6 PEDAL ASSEMBLY

REF. NO.	PART NO.	DESCRIPTION	JTEI				REMARKS
28	JW8-F7119-00	..WASHER	2				
29	JW8-F8319-00	..WASHER	1				
30	JW9-F7245-10	.PAD, BRAKE PEDAL	1				
31	JW8-F7316-01	.SPRING, SIDE STAND	1				
32	JW8-F7217-00	.BOLT	1				
33	JW9-F7445-31	.PLATE 1	1				
34	JW8-F7213-20	.COLLAR	1				
35	JW9-F7853-00	.SHAFT, PEDAL 1	1				
36	JW9-F7871-10	.PEDAL, ACCELERATOR	1				
37	JW9-F7872-20	.ARM, ACCELERATOR PEDAL	1				
38	JW8-F7438-00	.PIN, CLEVIS	1				
39	JW8-F7434-00	.BOLT	1				
40	JW8-F7317-00	.BOLT	1				
41	JW8-F7118-00	.NUT	1				
42	JW8-F815H-01	.SPRING	1				
43	JW8-F7814-21	.BUSH, PEDAL	2				
44	JW8-F4486-00	.O-RING	4				
45	JW9-F5673-00	.DAMPER, BRAKE	1				
46	JW9-F7246-20	.NAIL, BRAKE	1				
47	JW8-F8331-00	.BOLT, LEG SHIELD	2				
48	JW8-F4486-00	.O-RING	2				
49	JW9-F7263-00	.BRACKET 1	1				
50	JW9-F4648-20	.O-RING	1				
51	JW8-F41B8-00	.O-RING	1				
52	JW9-H5885-00	.THROTTLE SENSOR ASSY	1				
53	JW9-F5827-00	.SHIM, CALIPER	1				UR
	JW9-F5827-10	.SHIM, CALIPER	1				UR

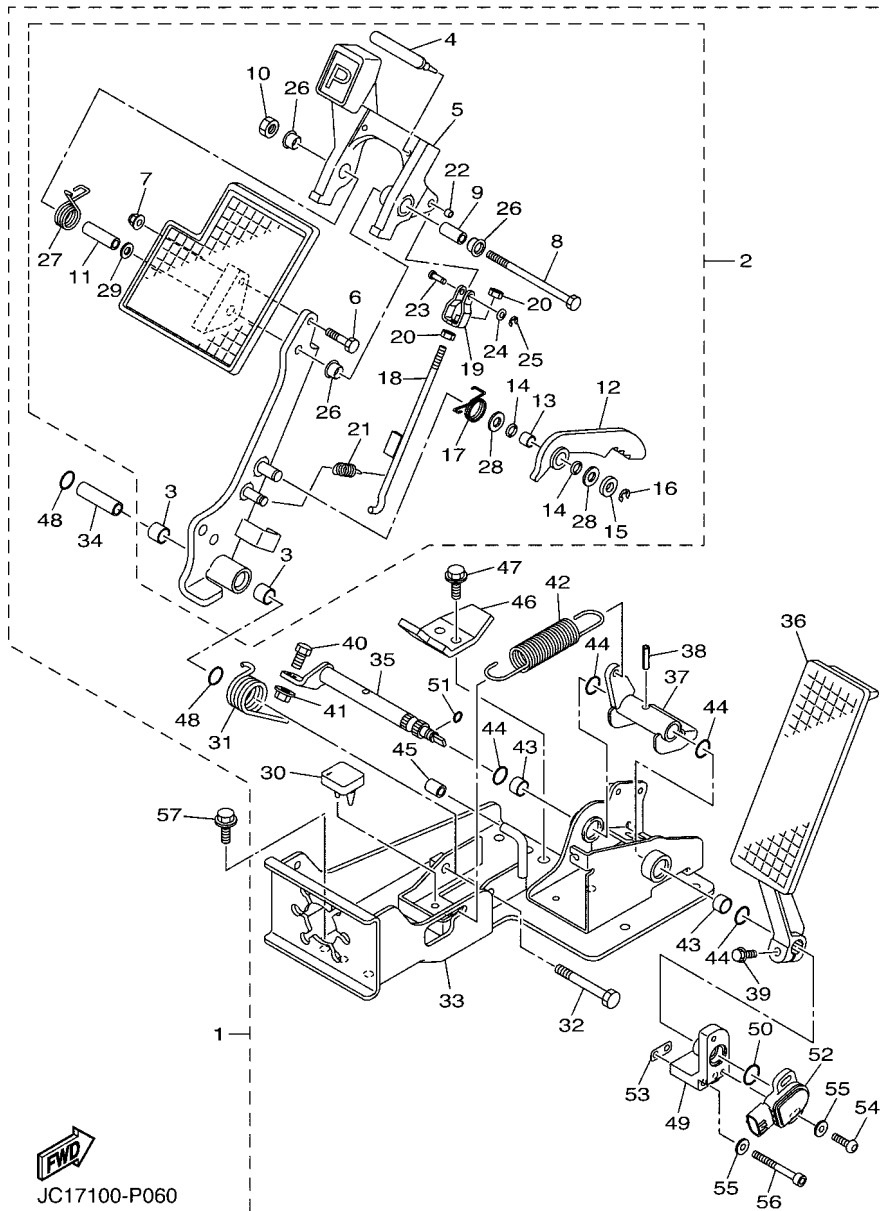

JC17100-P060

FIG. 6 PEDAL ASSEMBLY

REF. NO.	PART NO.	DESCRIPTION	JTEI				REMARKS
54	JW9-F632G-00	.SCREW	2				
55	90201-05824	.WASHER, PLATE	4				
56	JW8-F7435-00	.BOLT	2				
57	95812-08020	BOLT, FLANGE	6				



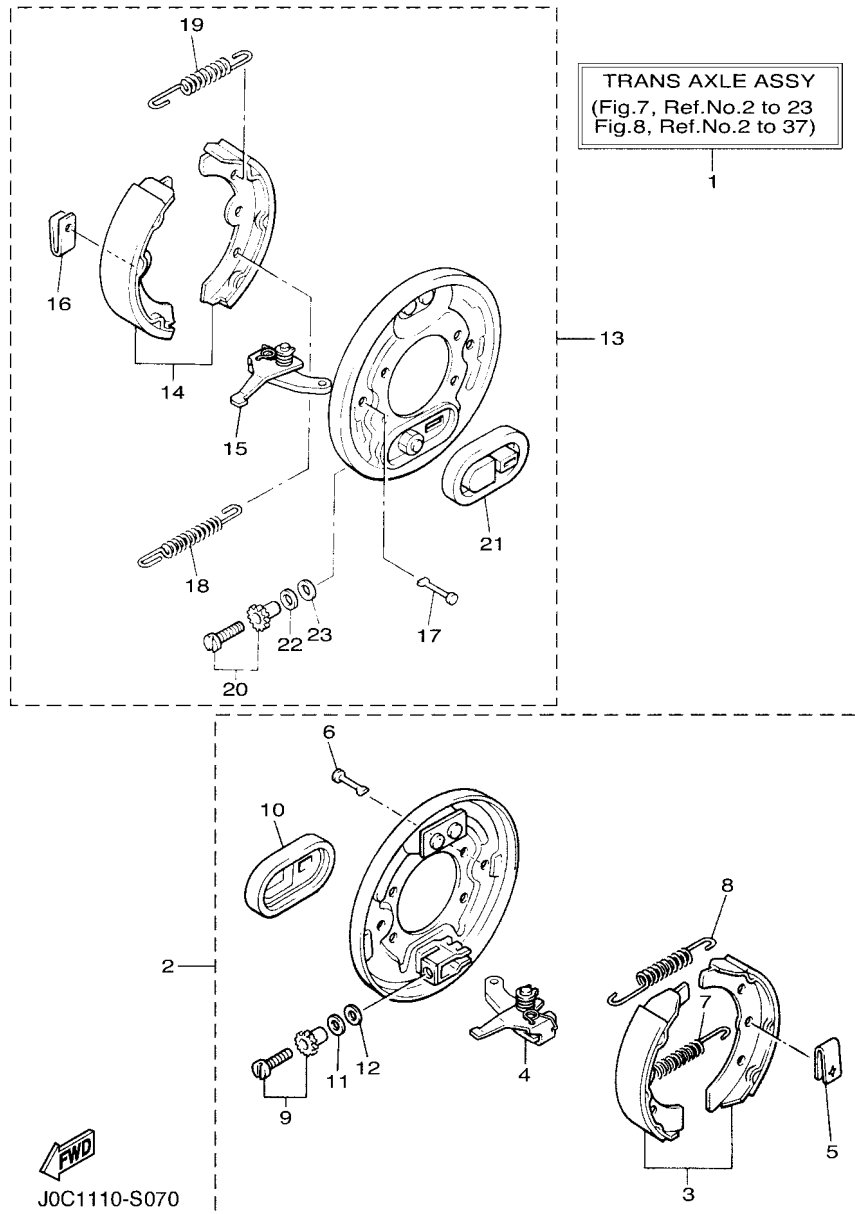

**FIG. 7 BRAKE**

REF. NO.	PART NO.	DESCRIPTION	JTEI				REMARKS
1	J0C-G6300-01	TRANS AXLE ASSY	1				
2	JW8-F7290-10	..BACKING PLATE ASSY 2	1				
3	JN9-W2536-11	..BRAKE SHOE SET	1				
4	J38-27205-00	..LEVER ASSY 2	1				
5	JW8-F7281-00	..SPRING, SHOE CLAMP	2				
6	J10-27282-00	..PIN, SHOE HOLD DOWN	2				
7	90506-20281	..SPRING, TENSION	1				
8	90506-14001	..SPRING, TENSION	1				
9	J55-27260-00	..ADJUSTER ASSY	1				
10	JW8-F7286-00	..COVER, DUST	1				
11	90201-121H9	..WASHER, PLATE	1				
12	90201-121H8	..WASHER, PLATE	1				
13	JW8-F7280-10	..BACKING PLATE ASSY 1	1				
14	JN9-W2536-11	..BRAKE SHOE SET	1				
15	J38-27204-00	..LEVER ASSY 1	1				
16	JW8-F7281-00	..SPRING, SHOE CLAMP	2				
17	J10-27282-00	..PIN, SHOE HOLD DOWN	2				
18	90506-20281	..SPRING, TENSION	1				
19	90506-14001	..SPRING, TENSION	1				
20	J55-27270-00	..ADJUSTER ASSY	1				
21	JW8-F7286-00	..COVER, DUST	1				
22	90201-121H9	..WASHER, PLATE	1				
23	90201-121H8	..WASHER, PLATE	1				

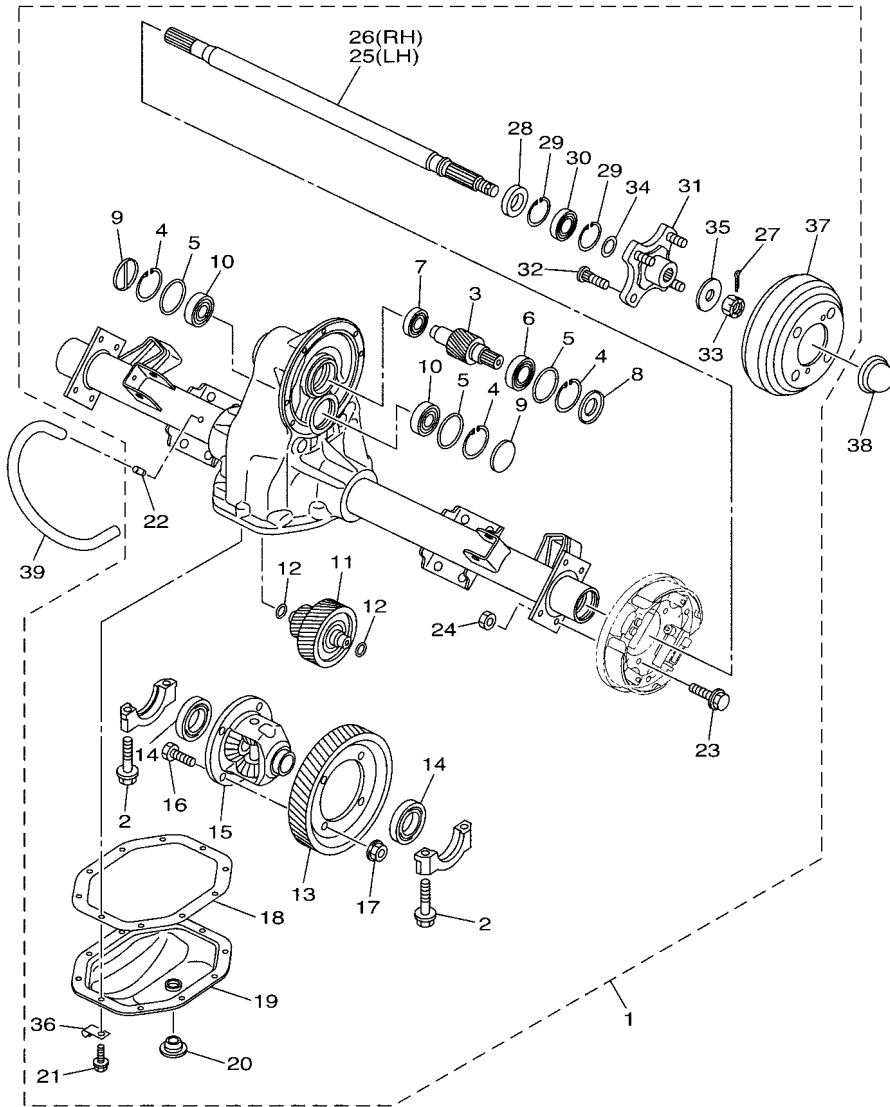

J0C1110-S080

FIG. 8 TRANSAXLE

REF. NO.	PART NO.	DESCRIPTION	JTEI				REMARKS
1	J0C-G6300-01	TRANS AXLE ASSY	1				
2	90105-10840	.BOLT, FLANGE	4				
3	JW9-G6321-00	.SHAFT, INPUT	1				
4	93420-50804	.CIRCLIP	3				
5	93210-478B8	.O-RING	3				
6	93306-005Y1	.BEARING	1				
7	93306-203X1	.BEARING	1				
8	JW9-G6136-00	.SEAL 1	1				
9	JH7-G3396-01	.PLUG, BLIND	2				
10	93306-303Y6	.BEARING	2				
11	JW9-G6350-00	.COUNTER GEAR ASSY	1				
12	93210-148B9	.O-RING	2				
13	JW9-G6421-00	.GEAR, RING	1				
14	93306-007Y0	.BEARING	2				
15	JW9-G6410-00	.DIFFERENTIAL ASSY.	1				
16	90101-10854	.BOLT	4				
17	90170-10840	.NUT	4				
18	JW9-G631A-00	.GSKT., CASE	1				
19	JW9-G6312-00	.CASE, TRANSMISSION 2	1				
20	JN3-G6432-00	.STOPPER	1				
21	90101-08856	.BOLT	10				
22	JW8-G5378-00	.NIPPLE, HOSE	1				
23	90101-08855	.BOLT	8				
24	90170-08841	.NUT	8				
25	JR1-G6511-00	.SHAFT, REAR AXLE 1 (L.H)	1				
26	JR1-G6512-00	.SHAFT, REAR AXLE 2 (R.H)	1				
27	91490-30030	.PIN. COTTER	2				

**FIG. 8 TRANSAXLE**

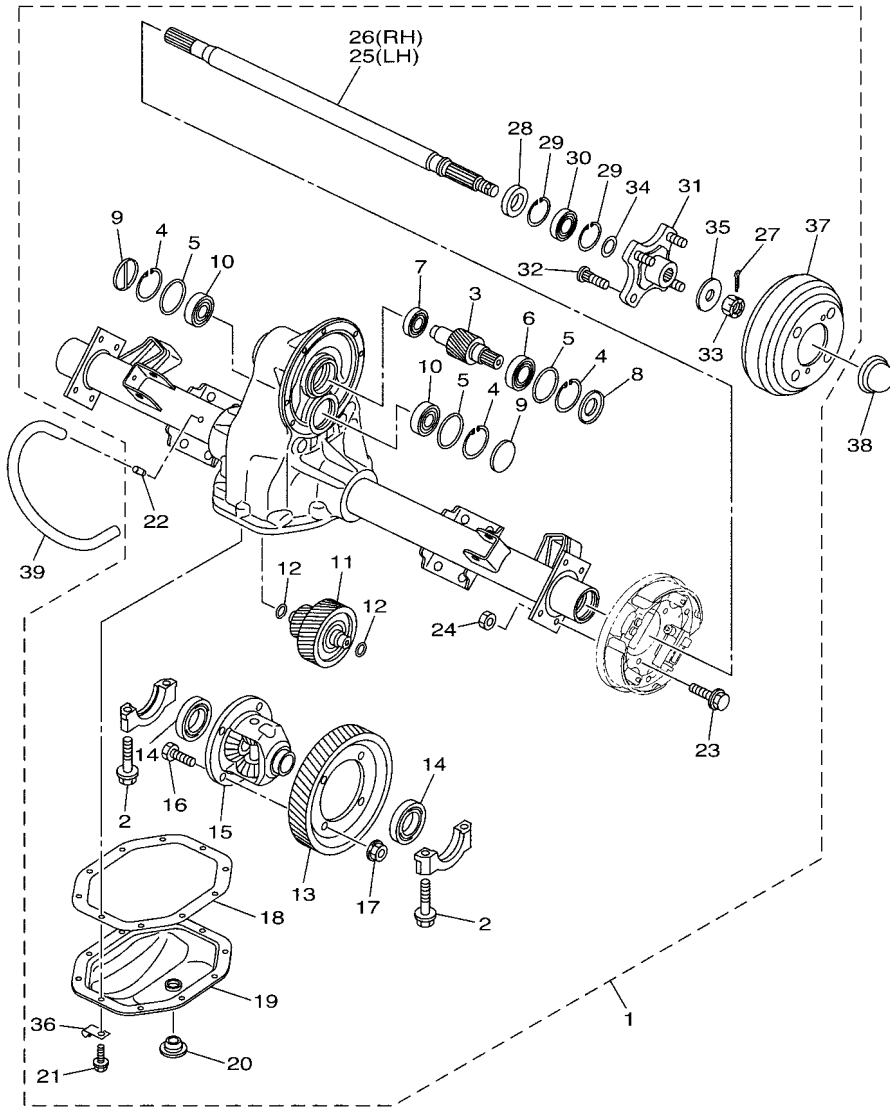

REF. NO.	PART NO.	DESCRIPTION	JTEI				REMARKS
28	93101-24822	.OIL SEAL	2				
29	93420-44805	.CIRCLIP	4				
30	93306-00440	.BEARING	2				
31	JW8-G6514-00	.HUB, REAR AXLE	2				
32	JW8-G4178-00	.BOLT, STUD	8				
33	JW8-G5244-00	.NUT	2				
34	JW8-G2535-00	.WASHER, THRUST	2				
35	JW8-G2536-00	.WASHER, THRUST 2	2				
36	JW8-G2756-00	.STAY, CLAMP	1				
37	JW8-G6521-00	.DRUM	2				
38	JW8-F5118-00	COVER, HUB DUST	2				
39	JW8-G2541-00	PIPE 1	1				



J0C1110-S080



**FIG. 10 WINDSHIELD**

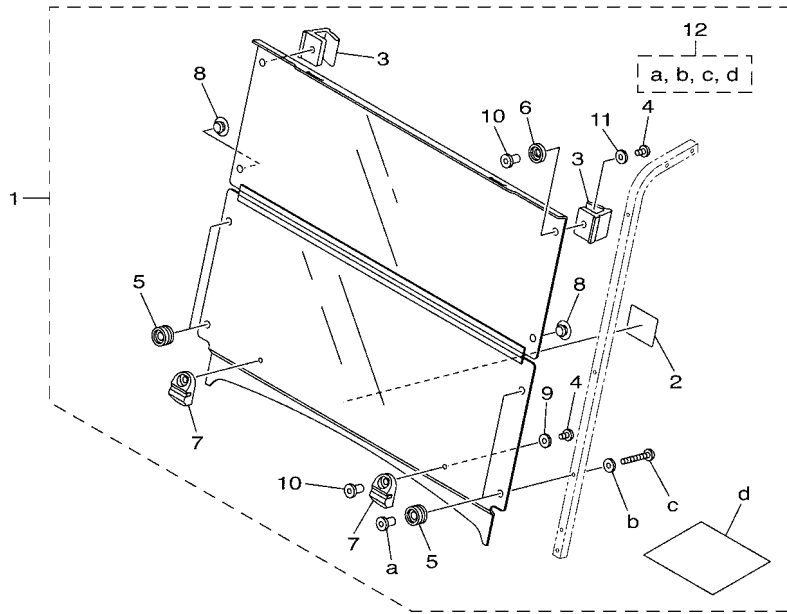

REF. NO.	PART NO.	DESCRIPTION	JTEI				REMARKS
1	J0B-K7200-20	WINDSHIELD ASSY	1				
2	J0B-K7458-00	.LABEL, WARNING	1				
3	J0B-K7173-20	.LEVER, LATCH 1	2				
4	J0B-K7258-00	.SCREW, 2	4				
5	J0B-K7237-00	.GROMMET	4				
6	J0B-K7247-00	.GROMMET, W/S 2	2				
7	J0B-K7257-00	.GROMMET, W/S 3	2				
8	J0B-K7238-00	.DAMPER	2				
9	J0B-K7218-00	.WASHER 1	2				
10	J0B-K7217-00	.NUT, WIND SHIELD	4				
11	J0B-K7219-00	.WASHER 2	2				
12	J0B-K7240-20	.WIND SHIELD HARDWARE KIT 1	1				



J1B1400-S100

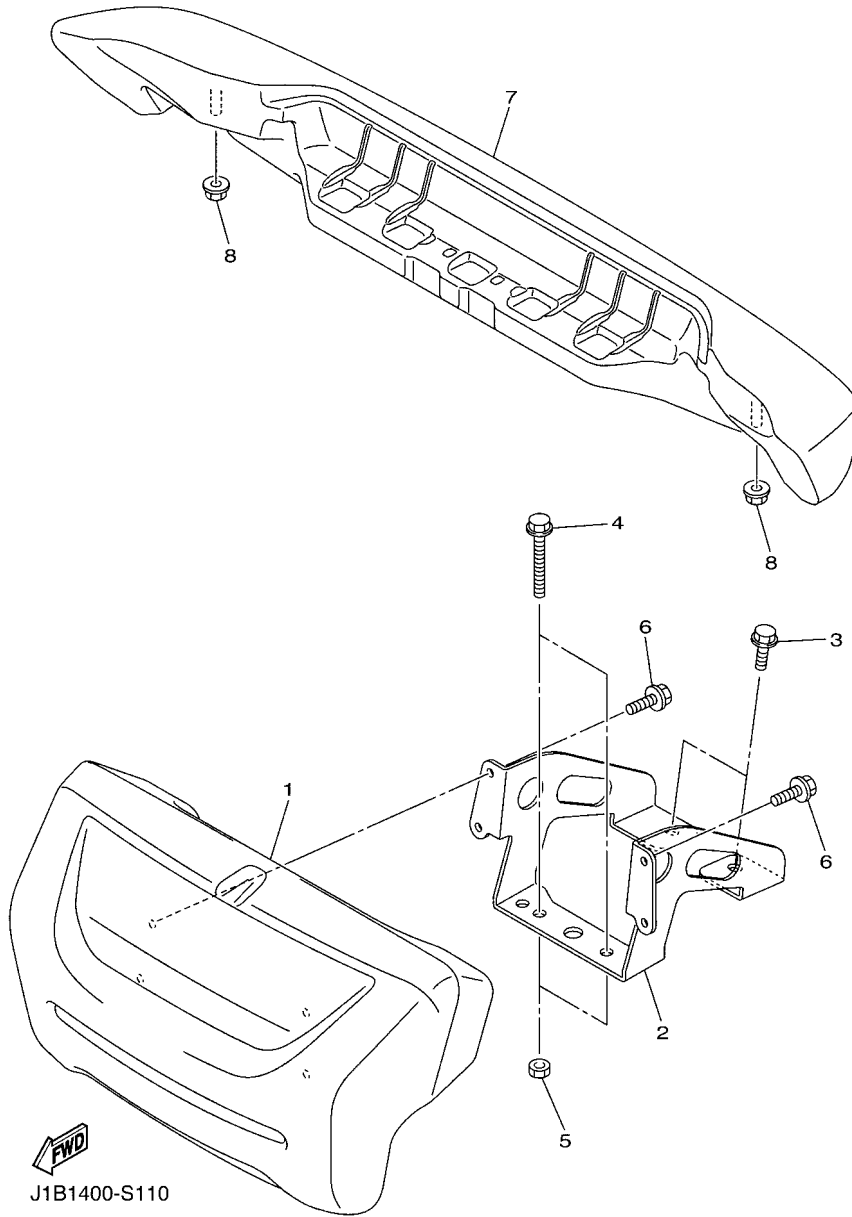

**FIG. 11 BUMPER**

REF. NO.	PART NO.	DESCRIPTION	JTEI				REMARKS
1	J0B-K7510-01	FRONT BUMPER COMP.	1				
2	J1B-K8164-00	STAY, FRONT BUMPER (L.H)	1				
3	95812-08016	BOLT, FLANGE	2				
4	95D32-08050	BOLT, FLANGE DEEP RECESS	2				
5	95302-08700	NUT, HEXAGON	2				
6	95822-06012	BOLT, FLANGE	4				
7	J0B-K7540-00	REAR BUMPER COMP.	1				
8	95602-10200	NUT, S/L FLANGE	2				

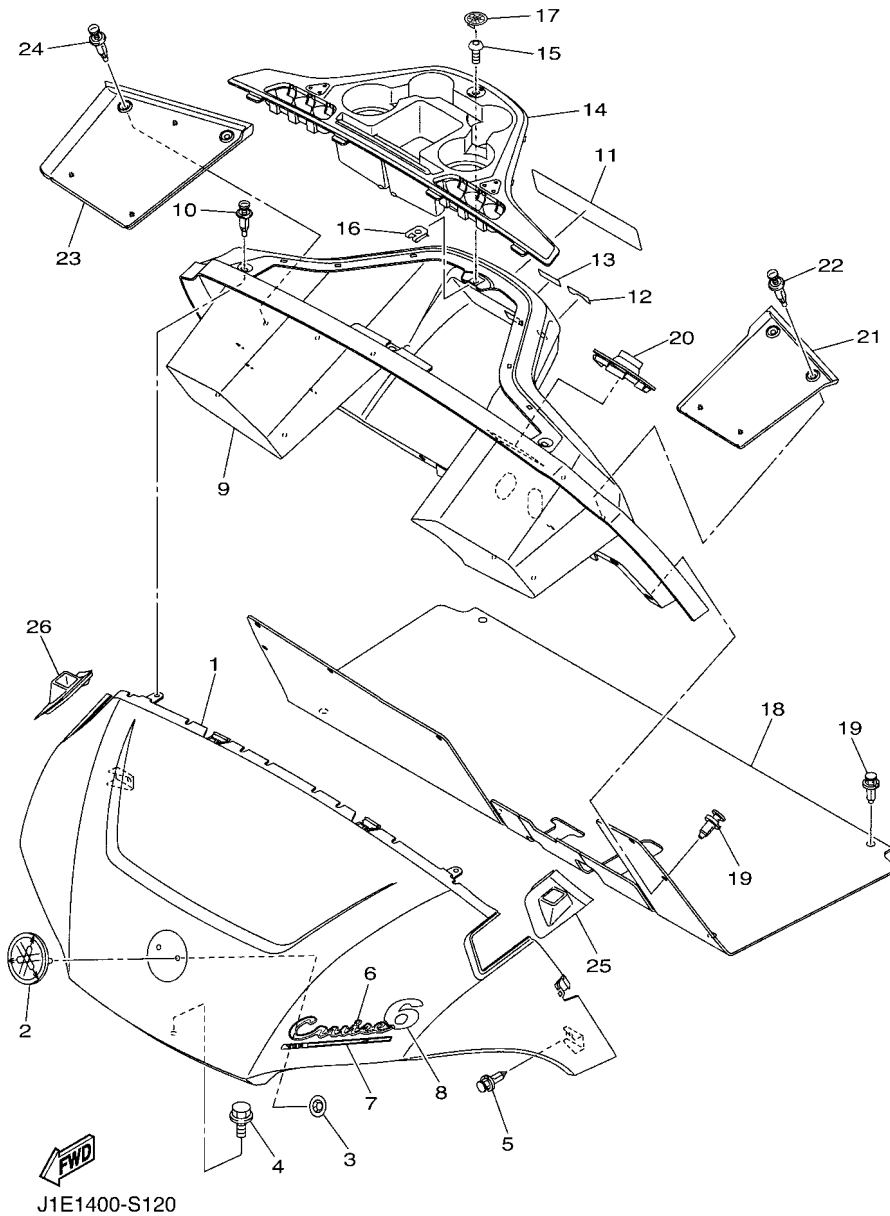
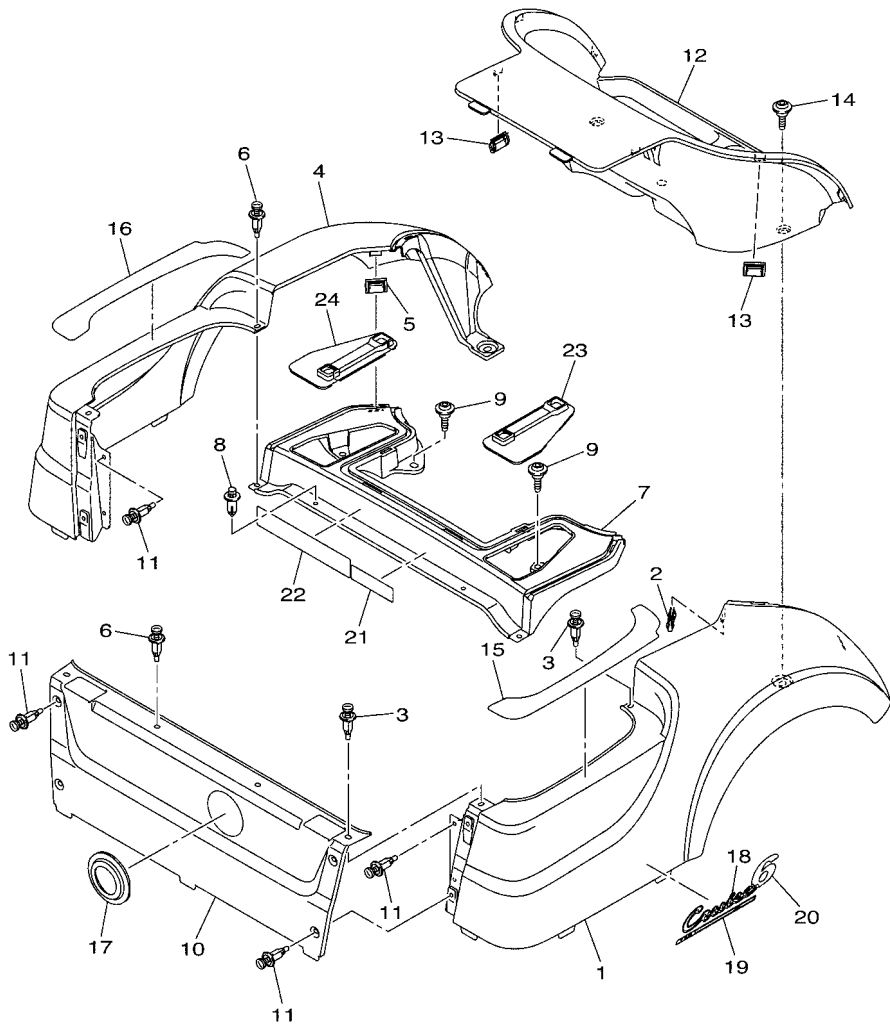

FIG. 12 BODY

REF. NO.	PART NO.	DESCRIPTION	J1E1				REMARKS
1	J0B-K8115-A0	COWL, FRONT	1				
2	J1B-F4161-00	EMBLEM 1	1				
3	JU0-K7573-00	NUT, SPECIAL	2				
4	95812-06012	BOLT, FLANGE	1				
5	90269-06804	RIVET	2				
6	J1A-K81A1-00	EMBLEM 1	1				
7	J1B-K81B1-00	GRAPHIC 1	1				
8	J1E-K81A2-00	EMBLEM 2	1				
9	J0C-K8114-01	PANEL, FRONT	1				
10	90269-07805	RIVET	3				
11	J1B-K7768-00	LABEL, WARNING 8	1				
12	J1B-K8282-00	PLATE, SWITCH PANEL	1				
13	J1B-K7741-00	INDICATOR 1	1				
14	J0B-K835E-00	HOLDER, BEVERAGE	1				
15	90111-05805	BOLT,HEX. SOCKET BUTTON	1				
16	90183-05008	NUT, SPRING	1				
17	J1B-H2370-00	PLUG CAP ASSY	1				
18	J0B-K8233-00	MAT, MAIN FLOOR 3	1				
19	90269-09003	RIVET	12				
20	J0B-K8273-02	COVER, HOLE	1				
21	J0B-K8243-00	MAT, REAR BODY SIDE (LH)	1				
22	90269-07805	RIVET	2				
23	J0B-K8244-00	MAT, REAR BODY SIDE (RH)	1				
24	90269-07805	RIVET	2				
25	J1B-K832F-00	GROMMET, ROOF SUPPORT 1	1				
26	J1B-K832G-00	GROMMET, ROOF SUPPORT 2	1				



J1E1400-S130

FIG. 13 BODY 2

REF. NO.	PART NO.	DESCRIPTION	J1E1				REMARKS
1	J0B-K8111-A0	PANEL, BODY SHELL	1				
2	J0B-F3447-00	CLIP	1				
3	90269-07805	RIVET	3				
4	J0B-K8112-A0	PANEL, BODY SHELL	1				
5	J0B-F3447-00	CLIP	1				
6	90269-07805	RIVET	3				
7	J0B-K819H-00	SHELL, REAR BODY	1				
8	JW7-K7329-00	RIVET	2				
9	J0B-F1738-00	BOLT	4				
10	J1B-K8141-00	PANEL, INTERMEDIATE BODY	1				
11	90269-07805	RIVET	8				
12	J0B-K8237-02	COVER, REAR FLOOR	1				
13	J0B-F3447-00	CLIP	4				
14	J0B-F1738-00	BOLT	2				
15	J0B-F2873-01	SEAL 1	1				
16	J0B-F2874-01	SEAL 2	1				
17	J0C-K827A-00	GUIDE 1	1				
18	J1A-K81A1-00	EMBLEM 1	2				
19	J1B-K81B1-00	GRAPHIC 1	2				
20	J1E-K81A2-00	EMBLEM 2	2				
21	J1A-K8298-00	PLATE, CAUTION 2	1				
22	J1A-K8297-00	PLATE, CAUTION 1	1				
23	J0B-K817H-00	TRIM, SIDE PANEL 1	1				
24	J0B-K817J-00	TRIM, SIDE PANEL 2	1				



**FIG. 14 BODY 3**

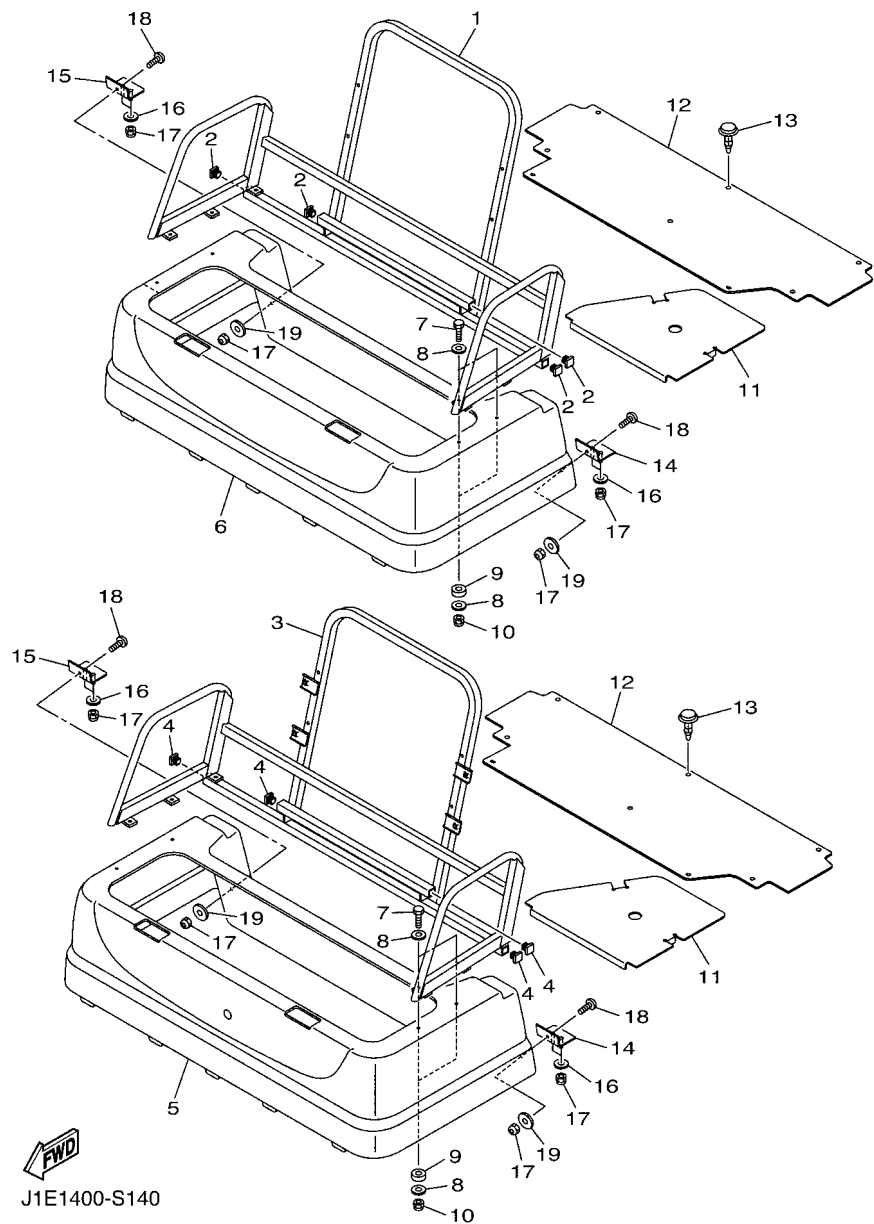

J1E1400-S140

REF. NO.	PART NO.	DESCRIPTION	J1E1				REMARKS
1	J1E-K8460-00	SEAT FRAME COMP.	1				
2	5FU-F111A-00	CAP, MAIN PIPE	4				
3	J1E-K8460-10	SEAT FRAME COMP.	1				
4	5FU-F111A-00	CAP, MAIN PIPE	4				
5	J2D-K8141-A0	PANEL, INTERMEDIATE BODY	1				
6	J2D-K8141-A0	PANEL, INTERMEDIATE BODY	1				
7	97027-06050	BOLT, HEXAGON	8				
8	92990-06200	WASHER, PLAIN	16				
9	J2B-K8328-00	SPACER 1	8				
10	95680-06100	NUT, U	8				
11	J1E-K811U-00	LID 2	2				
12	J2B-K8241-00	MAT, REAR FLOOR	2				
13	90269-09003	RIVET	16				
14	J1E-K8135-00	BRACKET 1	2				
15	J1E-K8136-00	BRACKET 2	2				
16	90201-06020	WASHER, PLATE	8				
17	95680-06100	NUT, U	12				
18	98580-06025	SCREW, PAN HEAD	4				
19	90201-06416	WASHER, PLATE	4				

**FIG. 15 BODY FITTING**

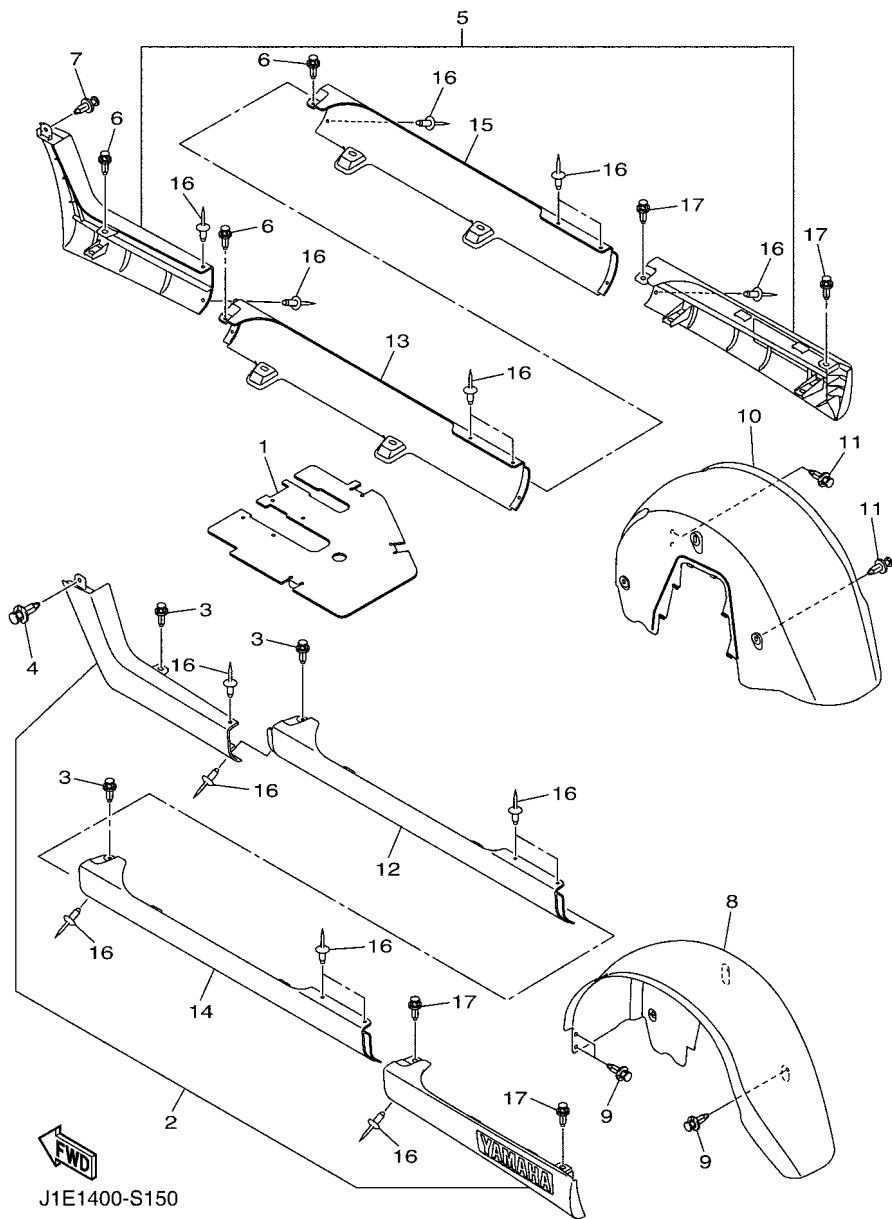

REF. NO.	PART NO.	DESCRIPTION	J1E1					REMARKS
1	J1B-K8271-00	SERVICE LID, PEDAL	1					
2	J1E-K818A-00	PROTECTOR, SIDE PLATE	1					
3	90269-09003	RIVET	3					
4	90269-06804	RIVET	1					
5	J1E-K818B-00	PROTECTOR, SIDE PLATE 2	1					
6	90269-09003	RIVET	3					
7	90269-06804	RIVET	1					
8	J0B-K8191-00	PANEL, REAR FENDER 1	1					
9	90269-06804	RIVET	5					
10	J0B-K8192-00	PANEL, REAR FENDER 2	1					
11	90269-06804	RIVET	5					
12	J1E-K8183-00	PLATE, SIDE SILL (L.H)	1					
13	J1E-K8184-00	PLATE, SIDE SILL (R.H)	1					
14	J1E-K8183-10	PLATE, SIDE SILL (L.H)	1					
15	J1E-K8184-10	PLATE, SIDE SILL (R.H)	1					
16	90267-48138	RIVET, BLIND	16					
17	90269-09003	RIVET	4					





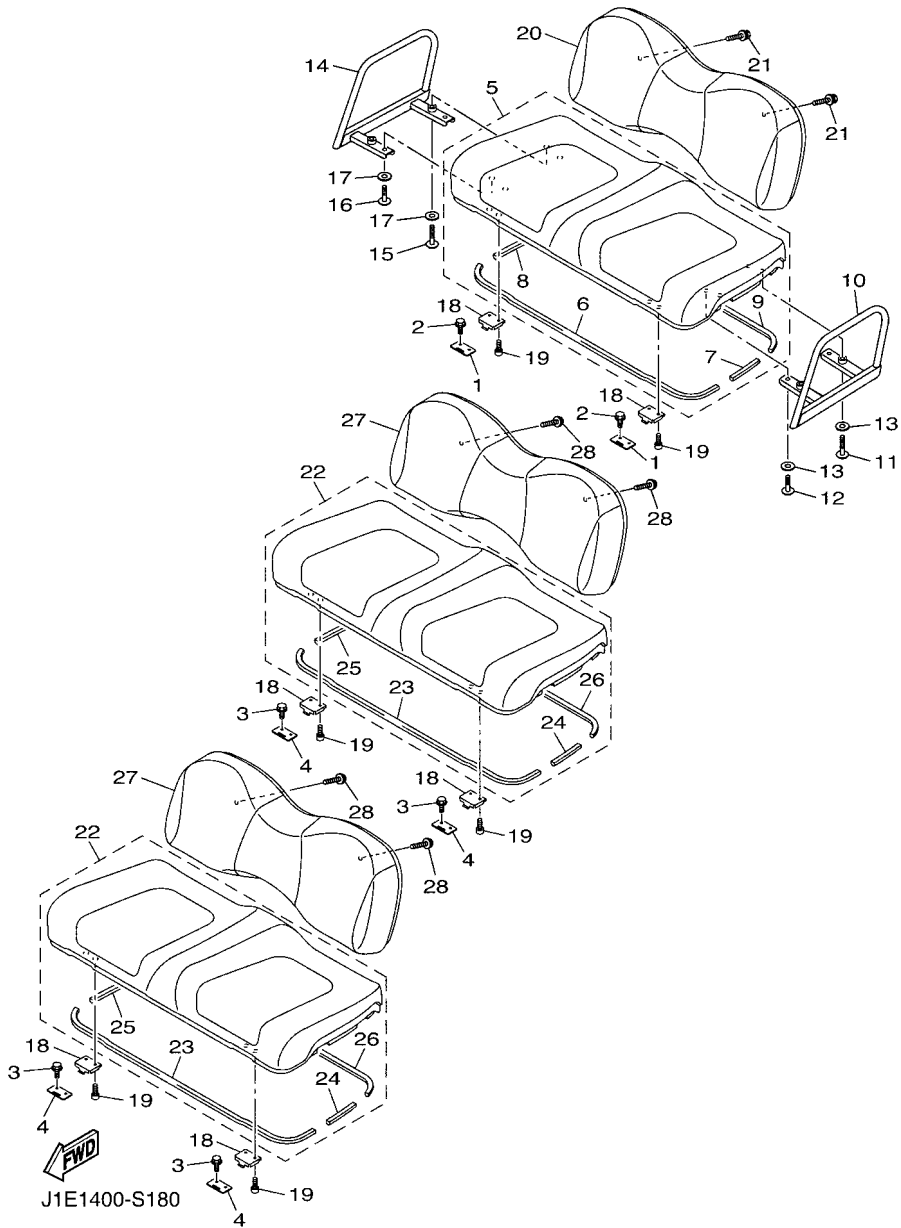
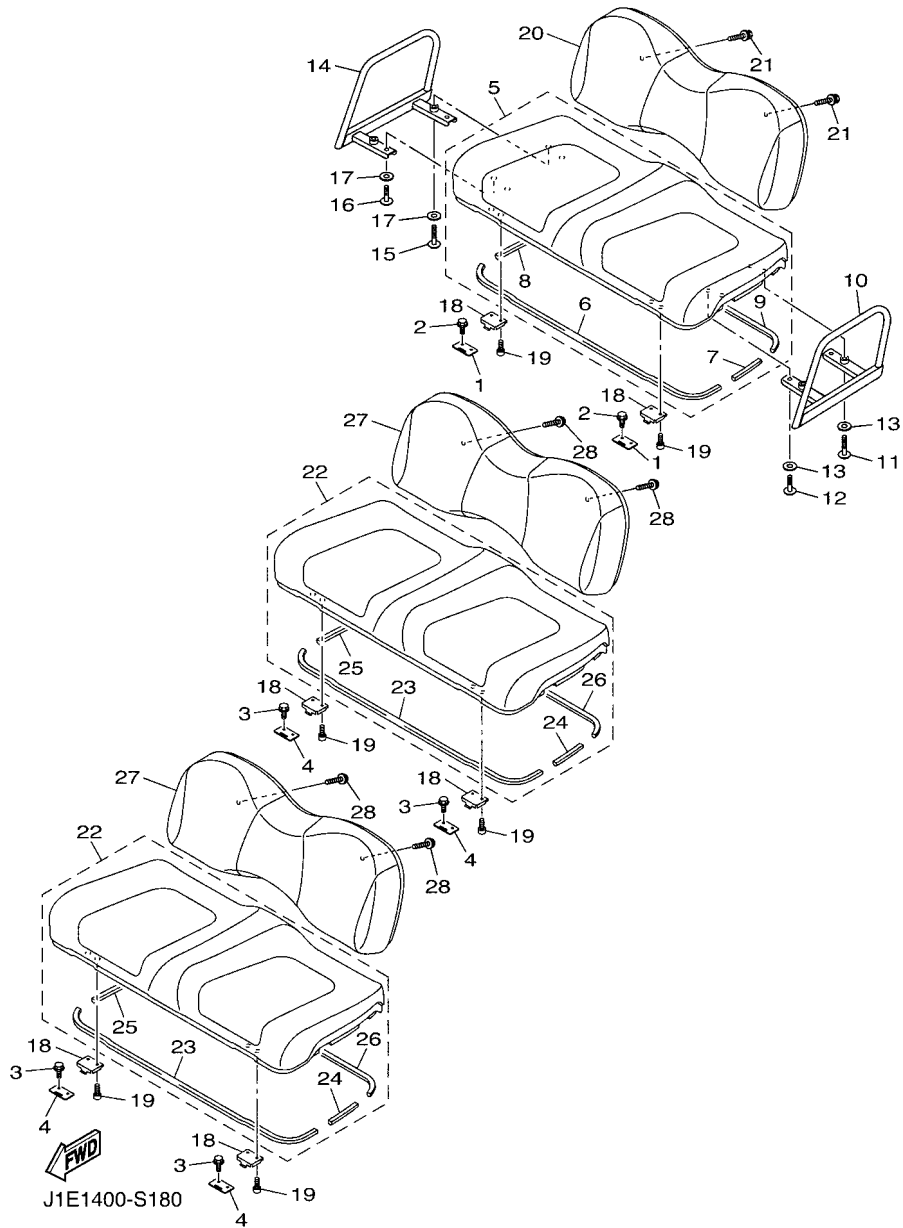

FIG. 18 SEAT

REF. NO.	PART NO.	DESCRIPTION	J1E1				REMARKS
1	J1A-K8427-00	HINGE, SEAT 2	2				
2	95802-06040	BOLT, FLANGE	4				
3	95802-06040	BOLT, FLANGE	8				
4	J1A-K8427-00	HINGE, SEAT 2	4				
5	J0A-K8401-00	SEAT SUB-ASSY,CUSHION	1				
6	J0B-K8245-00	.SEAL 1	1				
7	J0B-K8246-00	.SEAL 2	1				
8	J0B-K8247-00	.SEAL 3	1				
9	J0B-K8248-00	.SEAL 4	1				
10	J1E-K8361-00	ARM REST 1	1				
11	92012-06030	BOLT, BUTTON HEAD	2				
12	92012-06020	BOLT, BUTTON HEAD	2				
13	92902-06600	WASHER, PLATE	4				
14	J1E-K8362-00	ARM REST 2	1				
15	92012-06030	BOLT, BUTTON HEAD	2				
16	92012-06020	BOLT, BUTTON HEAD	2				
17	92902-06600	WASHER, PLATE	4				
18	J1B-K8426-00	HINGE, SEAT 1	6				
19	90110-06125	BOLT, HEXAGON SOCKET HEAD	12				
20	JW1-K8402-10	SEAT SUB ASSY, BACK	1				
21	97580-06540	BOLT, WITH WASHER	4				
22	J0A-K8401-00	SEAT SUB-ASSY,CUSHION	2				
23	J0B-K8245-00	.SEAL 1	1				
24	J0B-K8246-00	.SEAL 2	1				
25	J0B-K8247-00	.SEAL 3	1				
26	J0B-K8248-00	.SEAL 4	1				
27	JW1-K8402-10	SEAT SUB ASSY, BACK	2				



**FIG. 18 SEAT**

REF. NO.	PART NO.	DESCRIPTION	J1E1	REMARKS
28	92017-06040	BOLT, BUTTON HEAD	8	

**FIG. 19 ELECTRIC MOTOR**

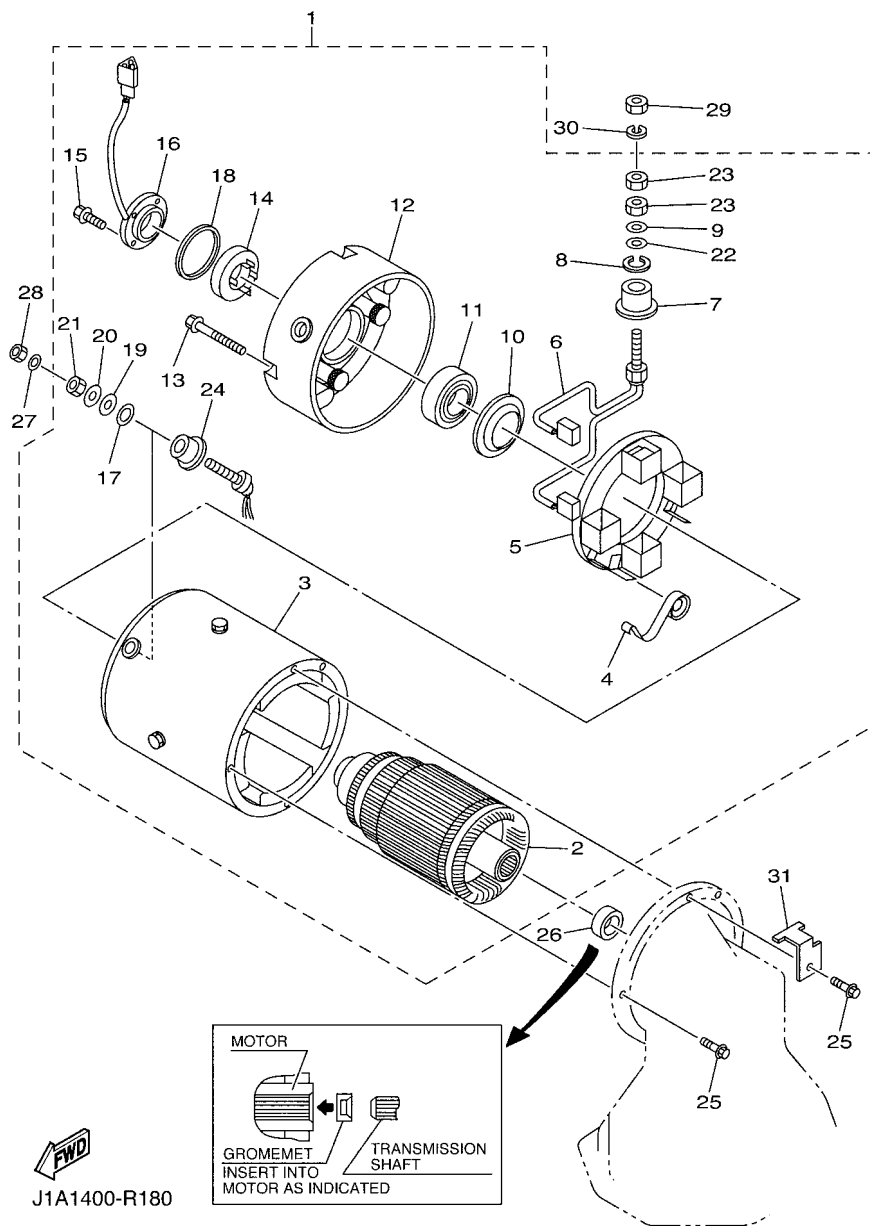

REF. NO.	PART NO.	DESCRIPTION	JTEI				REMARKS
1	JU2-H1890-23	MOTOR ASSY	1				
2	JU2-H1850-23	.ARMATURE ASSY	1				
3	JU2-H1160-20	.FIELD COIL ASSY	1				
4	JU2-H1617-20	.SPRING, BRUSH	4				
5	JU2-H1840-20	.BRUSH HOLDER ASSY	1				
6	JU2-H1801-20	.BRUSH SET	2				
7	JU2-H182G-20	.BUSH, TERMINAL	2				
8	JU2-H1843-20	.WASHER 1	2				
9	JU2-H181L-20	.WASHER, PLAIN	2				
10	JU2-H1856-20	.RETAINER	1				
11	JU2-H185B-20	.BEARING 1	1				
12	JU2-H183J-20	.BRACKET, FRONT	1				
13	JU2-H1828-20	.SCREW 2	4				
14	JU2-H181K-20	.MAGNET	1				
15	JU2-H2113-20	.SCREW	4				
16	JU2-H1670-22	.PICK-UP ASSY	1				
17	JU2-H272L-20	.INSULATOR, 1	2				
18	JU2-H5722-20	.INSULATOR	1				
19	JU2-H2517-20	.WASHER, SPECIAL	2				
20	JU2-H332D-20	.WASHER, SPECIAL 2	2				
21	JU2-H191B-20	.NUT	4				
22	JU2-H1824-20	.WASHER 2	2				
23	JU2-H182K-20	.NUT	4				
24	JU2-H182H-20	.BUSH, TERMINAL 2	2				
25	95812-06025	BOLT, FLANGE	3				
26	JH7-H1829-00	GROMMET	1				
27	JU2-H185A-20	WASHER, PLATE	2				







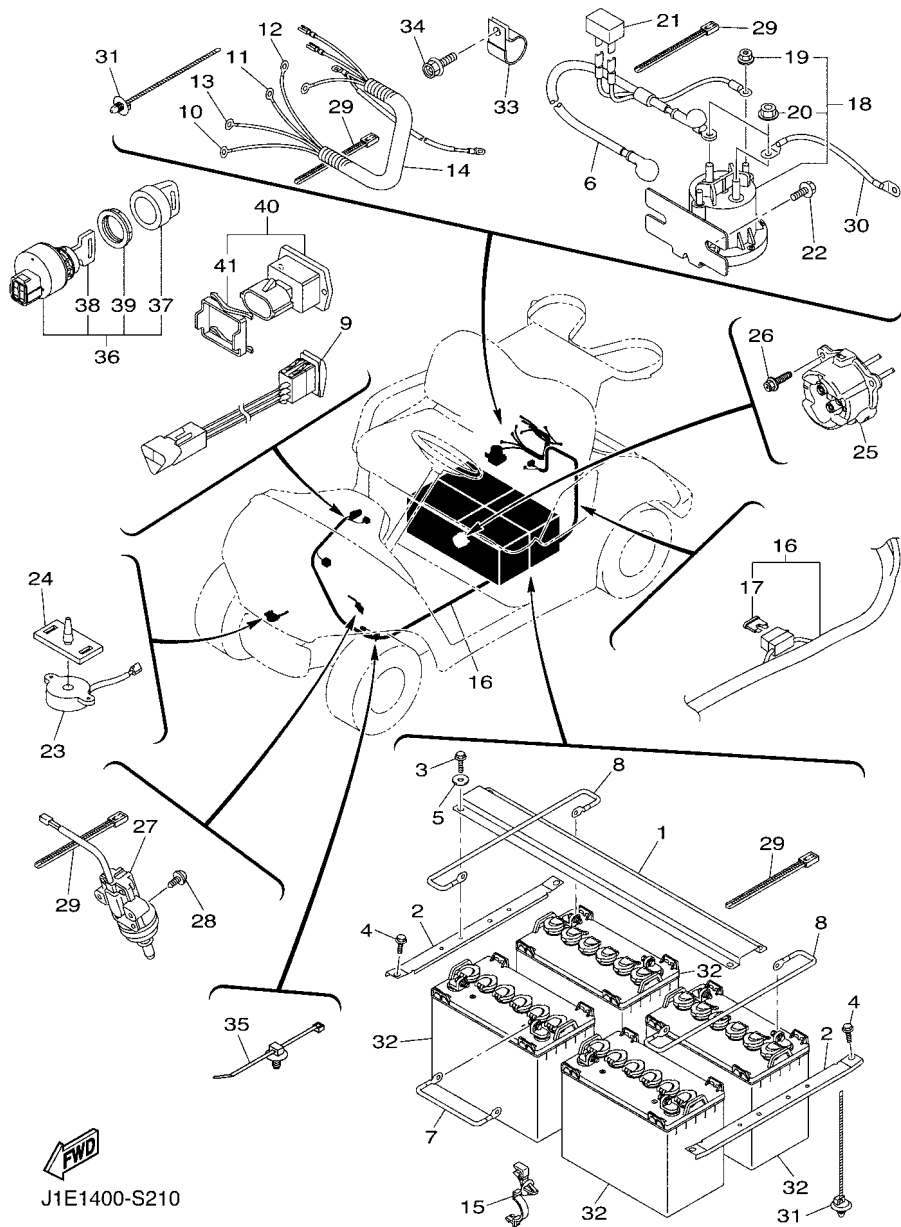

**FIG. 21 ELECTRICAL 1**

REF. NO.	PART NO.	DESCRIPTION	J1E1	REMARKS
1	J1A-H2136-01	PLATE, BATTERY FITTING	1	
2	J1A-H213E-01	PLATE, BETTERY FITTING	2	
3	97027-08020	BOLT, HEXAGON	4	
4	95822-08016	BOLT, FLANGE	4	
5	92907-08200	WASHER	4	
6	JW9-H2115-20	WIRE, PLUS LEAD	1	
7	J1B-H2127-00	WIRE, LEAD 2	1	
8	J1A-H2149-00	WIRE, LEAD 3	2	
9	JU2-H2917-00	SWITCH	1	
10	JU2-H2521-20	WIRE, LEAD	1	
11	JU2-H2531-20	WIRE, LEAD	1	
12	JU2-H6171-20	WIRE, LEAD 1	1	
13	JW9-H6172-00	WIRE, LEAD 2	1	
14	JU2-H7196-20	TUBE 1	1	
15	90464-20010	CLAMP	3	
16	J1E-H2590-00	WIRE HARNESS ASSY	1	
17	JR1-H2151-00	.FUSE (3A)	1	
18	JW9-H1950-20	RELAY ASSY	1	
19	90179-05807	.NUT	2	
20	90179-08824	.NUT	2	
21	JW9-85371-00	RESISTOR COMP.	1	
22	95822-06012	BOLT, FLANGE	2	
23	JR1-H3383-02	BUZZER	1	
24	JN6-H3386-01	STAY, BUZZER	1	
25	JW9-H6181-00	RECEPTACLE	1	
26	97502-05516	BOLT, WITH WASHER	3	
27	JF7-82817-22	SWITCH	1	

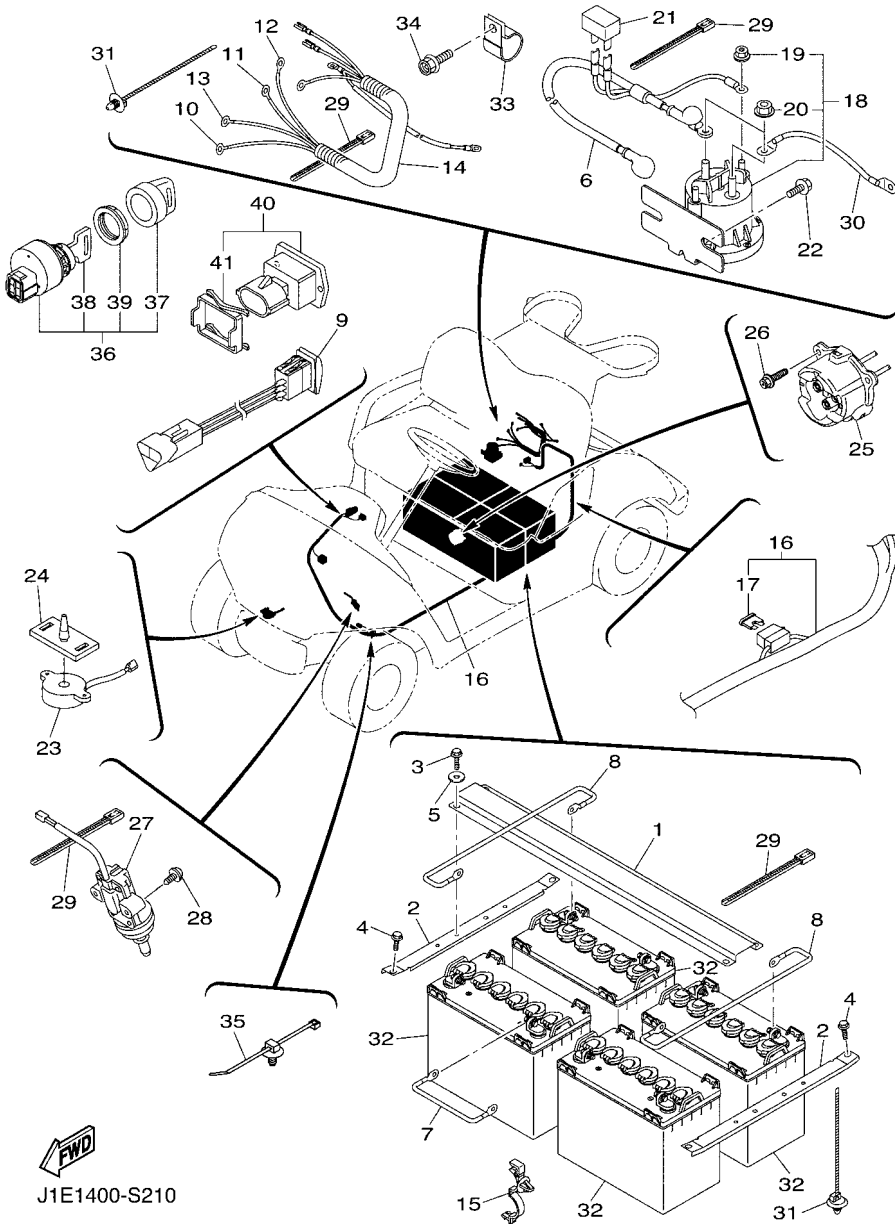

FIG. 21 ELECTRICAL 1

REF. NO.	PART NO.	DESCRIPTION	JTEI	REMARKS
28	97602-05225	SCREW, PAN HEAD WITH WASHER	2	
29	90464-32804	CLAMP	8	
30	JW2-H6527-00	WIRE 7	1	
31	90464-20005	CLAMP	8	
32	*	BATTERY (GS BV150Z)	4	LM
33	90461-14108	CLAMP	1	
34	95822-08016	BOLT, FLANGE	1	
35	1NS-F1338-00	CLAMP	1	
36	JW1-H2510-00	MAIN SWITCH ASSY	1	
37	5UG-H2579-00	.CAP, KEY	1	
38	JU2-H2511-00	.KEY, MAIN SWITCH	2	
39	JU6-H2569-00	.NUT, MAIN SWITCH	1	
40	JW2-H351B-00	GAUGE, BATTERY	1	
41	JW1-H1128-00	.CLAMP	1	



NUMERICAL INDEX

PART NO.	REF. NO.	PART NO.	REF. NO.	PART NO.	REF. NO.	PART NO.	REF. NO.	PART NO.	REF. NO.	PART NO.	REF. NO.
JX4-22123-00	1 - 2	J1B-F255G-00	2 - 2	JW8-F7118-00	6 - 41	JW8-G2541-00	8 - 39	JU2-H2113-20	19 - 15	JU0-K7573-00	12 - 3
J1A-23400-00	4 - 10	J1E-F255G-00	2 - 22	JW8-F7119-00	6 - 28	JW8-G2756-00	8 - 36	JW9-H2115-20	21 - 6	J1B-K7741-00	12 - 13
2NL-23448-00	3 - 9	J1B-F258E-00	2 - 6	JW8-F7119-00	6 - 13	JH7-G3396-01	8 - 9	J1B-H2127-00	21 - 7	JW8-K7762-00	4 - 37
J1A-23489-00	4 - 20	J0B-F2873-01	13 - 15	JW9-F7200-21	6 - 2	JW8-G4178-00	8 - 32	J1A-H2136-01	21 - 1	J1E-K7766-00	17 - 3
2NL-23517-00	3 - 11	J0B-F2874-01	13 - 16	JW8-F7213-20	6 - 34	JW8-G5244-00	8 - 33	J1A-H213E-01	21 - 2	J1B-K7768-00	12 - 11
2HR-23526-00	3 - 3	JW8-F3183-00	6 - 16	JW8-F7217-00	6 - 32	JW8-G5378-00	8 - 22	J1A-H2149-00	21 - 8	J0B-K8111-A0	13 - 1
J1A-23527-00	4 - 21	J0C-F3350-00	3 - 14	JW8-F7218-00	6 - 10	JW9-G6136-00	8 - 8	JR1-H2151-00	21 - 17	J0B-K8112-A0	13 - 4
JX4-23812-00	4 - 13	J0C-F3390-00	3 - 19	JW9-F7221-00	6 - 14	J0C-G6300-01	7 - 1	JU2-H218E-01	19 - 31	J0C-K8114-01	12 - 9
J1A-23822-00	4 - 29	J0B-F3447-00	13 - 2	JW9-F7228-00	6 - 23		8 - 1	JR1-H235A-00	22 - 2	J0B-K8115-A0	12 - 1
J1A-23837-00	4 - 22		13 - 5	JW9-F7231-10	6 - 18	JW9-G6312-00	8 - 19	J1B-H2370-00	12 - 17	J1E-K811U-00	14 - 11
JR7-23844-00	4 - 19		13 - 13	JW9-F7232-00	6 - 19	JW9-G631A-00	8 - 18	JW1-H2510-00	21 - 36	J1E-K8135-00	14 - 14
JX4-2384N-00	4 - 12	JU0-F3511-10	3 - 4	JW9-F7245-10	6 - 30	JW9-G6321-00	8 - 3	JU2-H2511-00	21 - 38	J1E-K8136-00	14 - 15
JR7-23866-00	4 - 24	JW1-F3512-00	3 - 5	JW9-F7246-20	6 - 46	JW9-G6350-00	8 - 11	JU2-H2517-20	19 - 19	J1B-K8141-00	13 - 10
J1A-2387A-00	4 - 11	JU0-F3521-10	3 - 12	JW9-F7263-00	6 - 49	JW9-G6410-00	8 - 15	JU2-H2521-20	21 - 10	J2D-K8141-A0	14 - 5
J1A-2387E-00	4 - 14	JU0-F3570-20	3 - 1	JW8-F7280-10	7 - 13	JW9-G6421-00	8 - 13	JU2-H2531-20	21 - 11		14 - 6
JR7-2387F-00	4 - 17	JW1-F3811-03	4 - 1	JW8-F7281-00	7 - 5	JN3-G6432-00	8 - 20	JU6-H2569-00	21 - 39	J1B-K8164-00	11 - 2
JR7-2387G-00	4 - 15	JU0-F3828-10	4 - 4		7 - 16	JR1-G6511-00	8 - 25	5UG-H2579-00	21 - 37	J1B-K816M-00	2 - 28
JR7-2387J-00	4 - 18	1P0-F3833-00	4 - 26	JW8-F7286-00	7 - 10	JR1-G6512-00	8 - 26	J1E-H2590-00	21 - 16	J0B-K817H-00	13 - 23
JR7-2387K-00	4 - 16	JN3-F3838-00	4 - 6		7 - 21	JW8-G6514-00	8 - 31	JW2-H2727-00	20 - 2	J0B-K817J-00	13 - 24
JR7-23894-00	4 - 25	J1A-F3841-00	4 - 27	JW8-F7290-10	7 - 2	JW8-G6521-00	8 - 37	JU2-H272L-20	19 - 17	J1E-K8183-00	15 - 12
JR7-2467K-00	4 - 23	JU0-F3857-11	4 - 3	JW8-F7316-01	6 - 31	JW1-H1128-00	21 - 41	JU2-H2917-00	21 - 9	J1E-K8183-10	15 - 14
J38-27204-00	7 - 15		4 - 5	JW8-F7317-00	6 - 40	JU2-H1160-20	19 - 3	JU2-H332D-20	19 - 20	J1E-K8184-00	15 - 13
J38-27205-00	7 - 4	J1B-F4161-00	12 - 2	JW8-F7318-00	6 - 20	JU2-H1617-20	19 - 4	JR1-H3383-02	21 - 23	J1E-K8184-10	15 - 15
J55-27260-00	7 - 9	JW8-F41B8-00	6 - 51	JW8-F7322-00	6 - 15	JU2-H1670-22	19 - 16	JN6-H3386-01	21 - 24	J1E-K818A-00	15 - 2
J55-27270-00	7 - 20	JW8-F4486-00	6 - 44	J1E-F7411-00	2 - 14	JU2-H1801-20	19 - 6	JW2-H351B-00	21 - 40	J1E-K818B-00	15 - 5
J10-27282-00	7 - 6		6 - 48	J1E-F7411-10	2 - 15	JU2-H181K-20	19 - 14	JU2-H5722-20	19 - 18	J0B-K8191-00	15 - 8
	7 - 17	JW9-F4648-20	6 - 50	J1E-F7411-20	2 - 4	JU2-H181L-20	19 - 9	JW9-H5885-00	6 - 52	J0B-K8192-00	15 - 10
JF7-82817-22	21 - 27	J1E-F5100-00	9 - 1	JW8-F7416-00	6 - 8	JU2-H1824-20	19 - 22	JU2-H6171-20	21 - 12	J0B-K819H-00	13 - 7
JW9-85371-00	21 - 21	JC1-F5103-00	3 - 21	JW8-F7426-01	6 - 17	JU2-H1828-20	19 - 13	JW9-H6172-00	21 - 13	J1A-K81A1-00	12 - 6
J1A-86510-00	20 - 1	JW8-F5118-00	8 - 38	JW8-F7434-00	6 - 39	JH7-H1829-00	19 - 26	JW9-H6181-00	21 - 25		13 - 18
5FU-F111A-00	14 - 2	JN6-F5118-01	3 - 29	JW8-F7435-00	6 - 56	JU2-H182A-20	19 - 28	J1E-H6515-00	20 - 6	J1E-K81A2-00	12 - 8
	14 - 4	JW8-F5415-00	6 - 25	JW8-F7438-00	6 - 38	JU2-H182G-20	19 - 7	JW2-H6527-00	21 - 30		13 - 20
	17 - 2	JW9-F5666-00	6 - 12	JW9-F7445-31	6 - 33	JU2-H182H-20	19 - 24	JU2-H7196-20	21 - 14	J1B-K81B1-00	12 - 7
1NS-F1338-00	21 - 35	JW9-F5671-00	6 - 5	J1E-F7452-00	2 - 21	JU2-H182K-20	19 - 23	J0B-K7173-20	10 - 3		13 - 19
J0B-F1738-00	2 - 5	JW9-F5672-00	6 - 4	JW8-F7814-21	6 - 3	JU2-H1835-20	19 - 30	J0B-K7200-20	10 - 1	J1B-K821A-00	2 - 27
	2 - 16	JW9-F5673-00	6 - 45		6 - 43	JU2-H183J-20	19 - 12	J0B-K7217-00	10 - 10	J0B-K8233-00	12 - 18
	13 - 9	JW8-F5681-10	5 - 5	JW8-F7825-01	6 - 27	JU2-H1840-20	19 - 5	J0B-K7218-00	10 - 9	J0B-K8237-02	13 - 12
	13 - 14	JN6-F5685-01	5 - 6	JW9-F7850-31	6 - 1	JU2-H1843-20	19 - 8	J0B-K7219-00	10 - 11	J2B-K8241-00	14 - 12
J1B-F2110-00	1 - 1	JW9-F5827-00	6 - 53	JW9-F7853-00	6 - 35	JU2-H1850-23	19 - 2	J0B-K7237-00	10 - 5	J0B-K8243-00	12 - 21
JN6-F2124-10	1 - 6	JW9-F5827-10	6 - 53	JW9-F7871-10	6 - 36	JU2-H1856-20	19 - 10	J0B-K7238-00	10 - 8	J0B-K8244-00	12 - 23
J1B-F2127-00	2 - 8	JW8-F6314-00	6 - 21	JW9-F7872-20	6 - 37	JU2-H185A-20	19 - 27	J0B-K7240-20	10 - 12	J0B-K8245-00	18 - 6
J1A-F2128-00	3 - 16	JW9-F632G-00	6 - 54	JW8-F815H-01	6 - 42	JU2-H185B-20	19 - 11	J0B-K7247-00	10 - 6		18 - 23
J1A-F217G-00	1 - 10	J1E-F6341-00	5 - 13	JW8-F8319-00	6 - 29	JU2-H1872-20	19 - 29	J0B-K7257-00	10 - 7	J0B-K8246-00	18 - 7
J1E-F2210-00	1 - 12	J1E-F6351-00	5 - 1	JW8-F8323-00	6 - 24	JU2-H1890-23	19 - 1	J0B-K7258-00	10 - 4		18 - 24
JW9-F2417-00	2 - 13	JW8-F639L-00	6 - 22	JW8-F8331-00	6 - 47	JU2-H191B-20	19 - 21	JW7-K7329-00	13 - 8	J0B-K8247-00	18 - 8
J1E-F2501-00	2 - 1	JW8-F639N-00	6 - 9	JW8-F8363-00	6 - 7	JW9-H1950-20	21 - 18	J0B-K7458-00	10 - 2		18 - 25
J1A-F252M-00	2 - 9	JW8-F7113-00	6 - 11	JW8-G2535-00	8 - 34	J1A-H1962-00	22 - 3	J0B-K7510-01	11 - 1	J0B-K8248-00	18 - 9
J1A-F2535-01	2 - 11	JW8-F7117-00	6 - 6	JW8-G2536-00	8 - 35	JW2-H2107-13	22 - 1	J0B-K7540-00	11 - 7		18 - 26

NUMERICAL INDEX

PART NO.	REF. NO.	PART NO.	REF. NO.	PART NO.	REF. NO.	PART NO.	REF. NO.	PART NO.	REF. NO.	PART NO.	REF. NO.
J1B-K8271-00	15 - 1	90170-08841	8 - 24	90464-20010	21 - 15	95602-12200	4 - 9				
J0B-K8273-02	12 - 20	90170-10840	8 - 17	90464-24230	5 - 4	95602-14100	3 - 28				
J0C-K827A-00	13 - 17	90176-06008	17 - 8	90464-24230	21 - 29	95612-12100	3 - 18				
J1B-K8282-00	12 - 12	90179-05807	21 - 19	90468-20196	5 - 3	95680-06100	2 - 18				
J1A-K8297-00	13 - 22	90179-08261	5 - 7	90502-10013	4 - 35		2 - 26				
J1A-K8298-00	13 - 21	90179-08824	21 - 20	90506-14001	7 - 8		14 - 10				
J2B-K8312-00	16 - 3	90179-12262	9 - 3		7 - 19		14 - 17				
J2B-K8313-00	16 - 5	90183-05008	12 - 16	90506-20281	7 - 7	95802-06040	18 - 2				
JDO-K8314-00	16 - 8	90185-12008	4 - 7		7 - 18		18 - 3				
J2B-K831A-00	16 - 6	90201-044H9	4 - 34	91490-25015	5 - 12	95812-06012	12 - 4				
J2B-K8328-00	14 - 9	90201-05824	6 - 55	91490-30030	8 - 27	95812-06025	19 - 25				
JPO-K8328-00	16 - 4	90201-06020	2 - 19	91702-08018	5 - 11	95812-08016	11 - 3				
J1B-K832F-00	12 - 25		2 - 24	91702-10026	5 - 2	95812-08020	4 - 2				
J1B-K832G-00	12 - 26		14 - 16	92012-06020	18 - 12		6 - 57				
JW1-K8340-00	17 - 5		17 - 7		18 - 16	95812-08040	2 - 3				
JW8-K8357-00	4 - 31	90201-06416	14 - 19	92012-06030	18 - 11	95812-10016	1 - 5				
JN6-K8358-01	4 - 32	90201-121H8	7 - 12		18 - 15	95812-10040	4 - 28				
J0B-K835E-00	12 - 14		7 - 23	92017-06040	17 - 6	95812-10055	1 - 13				
J1E-K8361-00	18 - 10	90201-121H9	7 - 11		18 - 28	95812-12065	1 - 7				
J1E-K8362-00	18 - 14		7 - 22	92902-06600	18 - 13	95812-12080	3 - 17				
J0A-K8401-00	18 - 5	90201-12426	1 - 9		18 - 17	95822-06012	11 - 6				
	18 - 22	90209-32271	3 - 27	92902-12200	4 - 8		21 - 22				
JW1-K8402-10	18 - 20	90249-14129	5 - 9	92907-08200	21 - 5	95822-06016	2 - 10				
	18 - 27	90267-48138	15 - 16	92990-06200	2 - 20		20 - 4				
J1E-K8423-00	17 - 1	90269-06804	12 - 5		2 - 25	95822-08016	2 - 7				
J1B-K8426-00	18 - 18		15 - 4		14 - 8		2 - 12				
J1A-K8427-00	18 - 1		15 - 7	93101-24822	8 - 28		21 - 4				
	18 - 4		15 - 9	93102-30803	3 - 26		21 - 34				
J1E-K8460-00	14 - 1		15 - 11	93210-148B9	8 - 12	95D02-06050	20 - 3				
J1E-K8460-10	14 - 3	90269-07805	12 - 10	93210-478B8	8 - 5	95D32-08030	2 - 29				
J2A-K84A0-00	16 - 1		12 - 22	93306-00440	8 - 30	95D32-08050	11 - 4				
J2A-K84A2-00	16 - 2		12 - 24	93306-005Y1	8 - 6	97027-06025	2 - 17				
J2A-K84B2-00	16 - 7		13 - 3	93306-005Y3	3 - 24	97027-06050	2 - 23				
JN9-W2536-11	7 - 3		13 - 6	93306-007Y0	8 - 14		14 - 7				
	7 - 14		13 - 11	93306-203X1	8 - 7	97027-08020	21 - 3				
90101-08855	8 - 23	90269-09003	12 - 19	93306-20437	3 - 23	97502-05516	21 - 26				
90101-08856	8 - 21		14 - 13	93306-303Y6	8 - 10	97512-08530	4 - 30				
90101-10854	8 - 16		15 - 3	93420-44805	8 - 29	97512-10620	1 - 11				
90105-10219	3 - 8		15 - 6	93420-50804	8 - 4	97580-06540	18 - 21				
90105-10267	3 - 13		15 - 17	93900-00825	9 - 2	97602-05225	21 - 28				
	3 - 20	90381-17800	3 - 10	95302-08700	11 - 5	97702-40525	4 - 33				
90105-10373	3 - 6	90381-18001	3 - 2	95307-08700	5 - 8	98580-06025	14 - 18				
90105-10840	8 - 2	90386-12800	6 - 26	95602-06200	20 - 5	99002-09600	5 - 10				
90105-12031	1 - 3	90387-046N7	4 - 36	95602-10200	1 - 14						
90109-08178	17 - 4	90387-12016	3 - 15		3 - 7						
90110-06125	18 - 19	90387-241M7	3 - 25		11 - 8						
90111-05805	12 - 15	90461-14108	21 - 33	95602-12200	1 - 4						
90114-12004	3 - 22	90464-20005	21 - 31		1 - 8						