

SR05 Rod type

● CE compliance ● Origin on the non-motor side is selectable: Lead 6, 12



Ordering method

SR05

Model	Lead	Model	Brake	Origin position	Bracket plate	Stroke	Cable length
	12: 12mm 06: 6mm 02: 2mm	S: Straight model R: Space-saving model (motor installed on right) L: Space-saving model (motor installed on left)	N: With no brake B: With brake	N: Standard Z: Non-motor side	N: No plate H: With plate V: With flange	50 to 300 (50mm pitch)	1K: 1m 3K: 3m 5K: 5m 10K: 10m

Note 1. See P.255 for grease gun nozzles.
 Note 2. When "2mm lead" is selected, the origin position cannot be changed (to non-motor side).
 Note 3. If changing from the origin position at the time of purchase, the machine reference amount must be reset. For details, refer to the manual.
 Note 4. The robot cable is flexible and resists bending.
 Note 5. See P.634 for DIN rail mounting bracket.
 Note 6. Select this selection when using the gateway function. For details, see P.96.

S2

Robot positioner	I/O
S2: TS-S2	NP: NPN PN: PNP CC: CC-Link DN: DeviceNet™ EP: EtherNet/IP™ PT: PROFINET GW: No I/O board

SH

Robot positioner	I/O	Battery
SH: TS-SH	NP: NPN PN: PNP CC: CC-Link DN: DeviceNet™ EP: EtherNet/IP™ PT: PROFINET GW: No I/O board	B: With battery (Absolute) N: None (Incremental)

SD

Robot driver	I/O cable
SD: TS-SD	1: 1m

Basic specifications

Motor	56 □ Step motor
Resolution (Pulse/rotation)	20480
Repeatability (mm)	+/-0.02
Deceleration mechanism	Ball screw φ12
Ball screw lead (mm)	12 6 2
Maximum speed (mm/sec)	300 150 50
Maximum payload (kg)	Horizontal 50 55 60 Vertical 10 20 30
Max. pressing force (N)	250 550 900
Stroke (mm)	50 to 300 (50pitch)
Lost motion	0.1mm or less
Rotating backlash (°)	+/-1.0
Overall length (mm)	Horizontal Stroke+276 Vertical Stroke+316
Maximum outside dimension of body cross-section (mm)	W56.4 × H71
Cable length (m)	Standard: 1 / Option: 3, 5, 10

Note 1. The maximum speed needs to be changed in accordance with the payload.
 See the "Speed vs. payload" graph shown on the right.
 For details, see P. 254.

Speed vs. payload

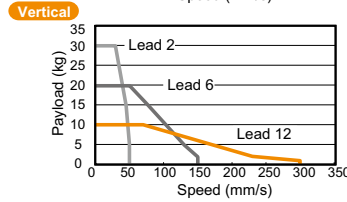
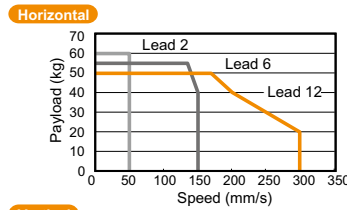

Running life

5000 km on models other than shown below.
 Running life of only the model shown below becomes shorter than 5000 km depending on the payload, so check the running life curve.

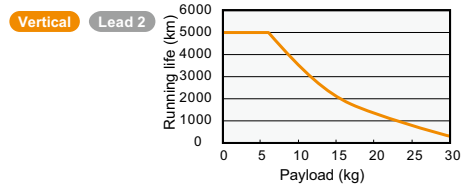

Note. See P.255 for running life distance to life time conversion example.

Motor installation (Space-saving model)

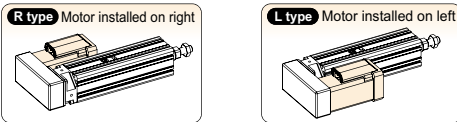

Controller

Controller	Operation method	Controller	Operation method
TS-S2	I/O point trace / Remote command	TS-SD	Pulse train control

SR05 Straight model S

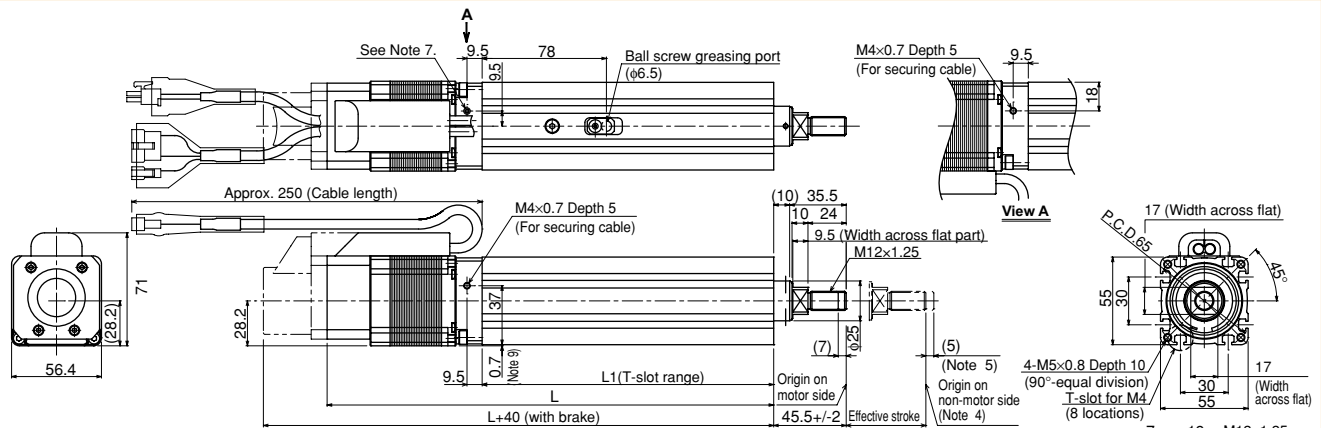

Option: Horizontal installation plate (foot)
 * Contents of option: Plate, 2 pcs., Nut, 8 pcs.
 See our robot manuals for additional settings.

Option: Vertical installation plate (flange)
 Hex. socket head cap bolt (M5x0.8), Length under head 14

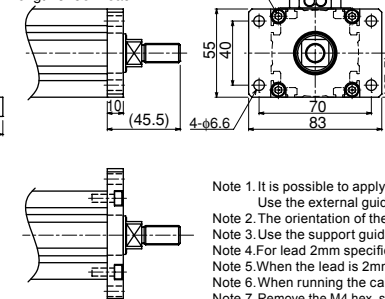
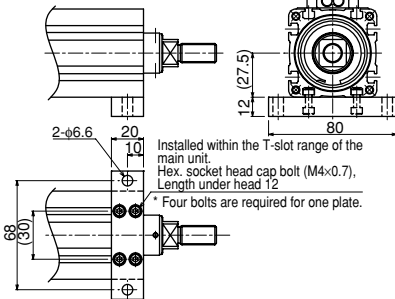

Effective stroke	50	100	150	200	250	300
L1	183	233	283	333	383	433
L	280.5	330.5	380.5	430.5	480.5	530.5
Weight (kg)	2.2	2.6	3.0	3.3	3.7	4.1

Note 1. It is possible to apply only the axial load.
 Note 2. Use the external guide together so that any radial load is not applied to the rod.
 Note 3. The orientation of the width across flat part is undefined to the base surface.
 Note 4. Use the support guide together to maintain the straightness.
 Note 5. For lead 2mm specifications, the origin on the non-motor side cannot be set.
 Note 6. When the lead is 2mm, this dimension is 27mm.
 Note 7. When running the cables, secure cables so that any load is not applied to them.
 Note 8. Remove the M4 hex. socket head cap set bolts and use them to secure the cables. (Effective screw thread depth 5)
 Note 9. The cable's minimum bend radius is R30.
 Note 10. Models with a brake will be 0.2kg heavier.
 Note 11. Distance to mechanical stopper.

SR05 Space-saving model (motor installed on right) **R**

Approx. 245 (Cable length)

146 (with brake)
106

45.5^{+/-2} Effective stroke (5)(Note 8, Note 12)

7 (Note 8)

Origin on motor side

Origin on non-motor side (Note 9)

M4x0.7 (9.9)

3.2

Dimensions of attached square nut for T-slot (6 pcs.)

7.3
4.3
1.5
6

M12x1.25 19 7
(21.9)

Dimensions of attached nut

Detail of section B

28.5 70

T-slot for M4 (8 locations)

4-M5x0.8 Depth 10 (90°-equal division)

17 (Width across flat)

55 30 30 56.5 71

9.5 (Width across flat part)

10 24 17 (Width across flat)

35.5 (10)

56.4

Option: Horizontal installation plate (foot)

* Contents of option: Plate, 2 pcs., Nut, 8 pcs. See our robot manuals for additional settings.

M4x0.7 Depth 5 (For securing cable)

M4x0.7 Depth 5 (For securing cable)

Option: Vertical installation plate (flange)

Hex. socket head cap bolt (M5x0.8), Length under head 14

4-φ6.6 drill-through

2-φ6.6 drill-through

Installed within the T-slot range of the main unit. (Hex. socket head cap bolt (M4x0.7), Length under head 12)

* Four bolts are required for one plate.

Effective stroke	50	100	150	200	250	300
L1	183	233	283	333	383	433
L	227.5	277.5	327.5	377.5	427.5	477.5
Weight (kg) ^{Note 7}	2.4	2.8	3.2	3.5	3.9	4.3

Note 1. It is possible to apply only the axial load.
 Note 2. Use the external guide together so that any radial load is not applied to the rod.
 Note 3. The orientation of the width across flat part is undefined to the base surface.
 Note 4. Use the support guide together to maintain the straightness.
 Note 5. When running the cables, secure cables so that any load is not applied to them.
 Note 6. Remove the M4 hex. socket head cap set bolts and use them to secure the cables. (Effective screw thread depth 5)
 Note 7. The cable's minimum bend radius is R30.
 Note 8. Models with a brake will be 0.2kg heavier.
 Note 9. Distance to mechanical stopper.
 Note 10. For lead 2mm specifications, the origin on the non-motor side cannot be set.
 Note 11. This unit can be installed with the motor facing up (turned 90 degrees from the position in this drawing).
 Note 12. Take great care as the outer case of the motor and cover belt projects from the bottom of the main unit.
 Note 13. When the lead is 2mm, this dimension is 27mm.

SR05 Space-saving model (motor installed on left) **L**

Approx. 245 (Cable length)

106

146 (with brake)

45.5^{+/-2} Effective stroke (5)(Note 8, Note 12)

7 (Note 8)

Origin on motor side

Origin on non-motor side (Note 9)

M4x0.7 (9.9)

3.2

Dimensions of attached square nut for T-slot (6 pcs.)

7.3
4.3
1.5
6

M12x1.25 19 7
(21.9)

Dimensions of attached nut

Detail of section B

28.5 70

T-slot for M4 (8 locations)

4-M5x0.8 Depth 10 (90°-equal division)

17 (Width across flat)

55 30 30 56.5 71

9.5 (Width across flat part)

10 24 17 (Width across flat)

35.5 (10)

Option: Horizontal installation plate (foot)

* Contents of option: Plate, 2 pcs., Nut, 8 pcs. See our robot manuals for additional settings.

M4x0.7 Depth 5 (For securing cable)

M4x0.7 Depth 5 (For securing cable)

Option: Vertical installation plate (flange)

Hex. socket head cap bolt (M5x0.8), Length under head 14

4-φ6.6 drill-through

2-φ6.6 drill-through

Installed within the T-slot range of the main unit. (Hex. socket head cap bolt (M4x0.7), Length under head 12)

* Four bolts are required for one plate.

Effective stroke	50	100	150	200	250	300
L1	183	233	283	333	383	433
L	227.5	277.5	327.5	377.5	427.5	477.5
Weight (kg) ^{Note 7}	2.4	2.8	3.2	3.5	3.9	4.3

Note 1. It is possible to apply only the axial load.
 Note 2. Use the external guide together so that any radial load is not applied to the rod.
 Note 3. The orientation of the width across flat part is undefined to the base surface.
 Note 4. Use the support guide together to maintain the straightness.
 Note 5. When running the cables, secure cables so that any load is not applied to them.
 Note 6. Remove the M4 hex. socket head cap set bolts and use them to secure the cables. (Effective screw thread depth 5)
 Note 7. The cable's minimum bend radius is R30.
 Note 8. Models with a brake will be 0.2kg heavier.
 Note 9. Distance to mechanical stopper.
 Note 10. For lead 2mm specifications, the origin on the non-motor side cannot be set.
 Note 11. This unit can be installed with the motor facing up (turned 90 degrees from the position in this drawing).
 Note 12. Take great care as the outer case of the motor and cover belt projects from the bottom of the main unit.
 Note 13. When the lead is 2mm, this dimension is 27mm.