

YRG-2005SS



Basic specifications

Model name		YRG-2005SS
Holding power	Max. continuous rating (N)	5
	Min. setting (% (N))	30 (1.5)
	Resolution (% (N))	1 (0.05)
Open/close stroke (mm)		3.2
Speed	Max. rating (mm/sec)	100
	Min. setting (% (mm/sec))	20 (20)
	Resolution (% (mm/sec))	1 (1)
	Holding speed (Max.) (%)	50
Repetitive positioning accuracy (mm)		+/-0.02
Guide mechanism		Linear guide
Max. holding weight ^{Note 1} (kg)		0.05
Weight (g)		90

- Holding power control : 30 to 100% (1% steps)
- Speed control : 20 to 100% (1% steps)
- Acceleration control : 1 to 100% (1% steps)
- Multipoint position control : 10,000 max.

Note. Design the finger as short and lightweight as possible.
 Note. Set the parameters and holding power (%) of the holding movement command so that any excessive shock is not applied to the finger during operation.
 Note. When installing or uninstalling the finger, tighten the bolts while the finger is being held securely so that any excessive force or shock is not applied to the guide block.
 Note. Workpiece weight that is able to be held may greatly vary depending on the material, shape, and/or holding surface conditions of the finger.

Note 1. Design the weight of a workpiece to be held so that it is approximately 1/10 to 1/20 of the holding power.
 (Consider further allowance when moving and swinging the gripper that keeps holding a workpiece.)

Gripping power vs. gripping power setting (%)

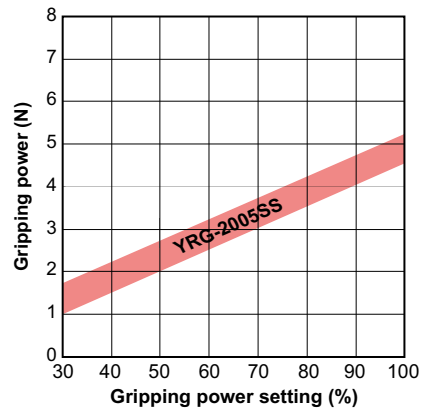

• Graph shows a general guide to gripping power versus gripping power setting (%). Variations will appear in the actual gripping power.

Allowable load and load moment

		YRG-2005SS		
Guide	Allowable load	F	N	12
	Allowable pitching moment	Mp	N•m	0.04
	Allowable yawing moment	My	N•m	0.04
	Allowable rolling moment	Mr	N•m	0.08
Finger	Max. weight (1 pair)		g	10
	Max. holding position	L	mm	20
	Max. overhang	H	mm	20

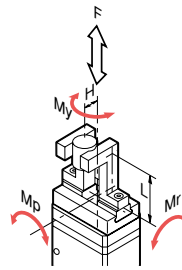

- Mount the finger so that the allowable load and load moment of the guide do not exceed the values stated in the table above.
- Make the adjustment so that the finger weight, holding length (L) from the installation surface to the holding point, and overhang (H) do not exceed the values stated in the table above.
- Please contact your YAMAHA sales dealer for further information on combination of L and H.

YRG-2005SS

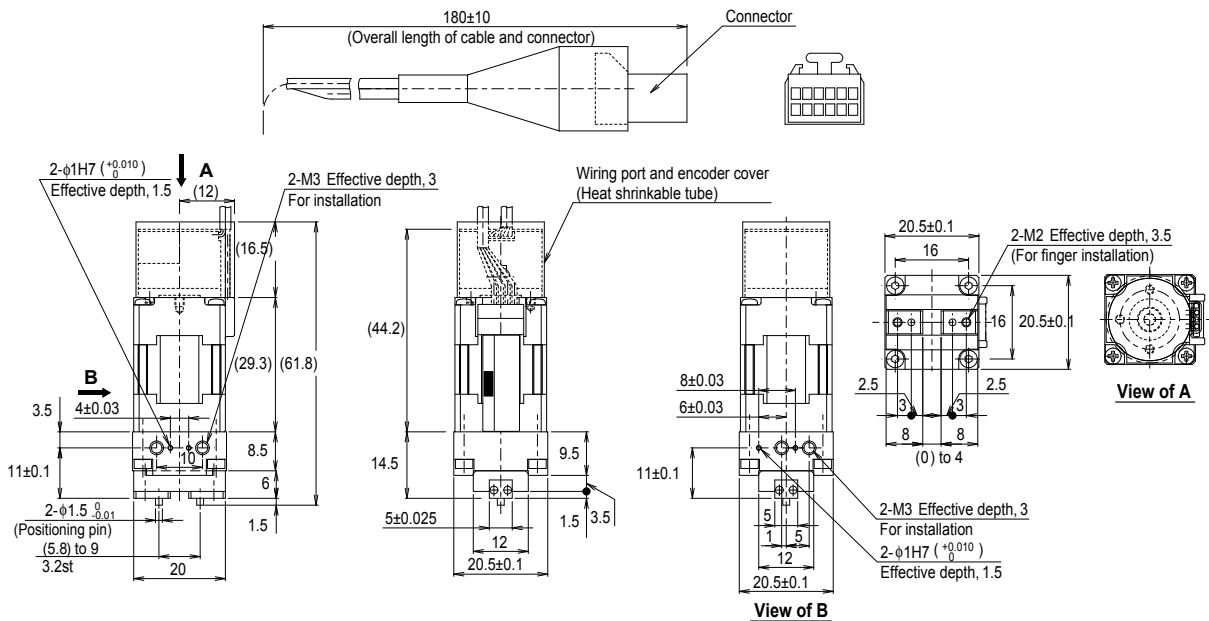

Note. Avoid extreme winding of the cable and fix the cable securely so that it does not move. Take appropriate measures so that any excessive force is not applied to the root of the cable.

APPLICATION
 Linear motor modules
 LCMT100
 Compact single-axis robots
 TRANSERVO
 Single-axis robots
 FLIP-X
 Linear motor single-axis robots
 PHASER
 Cartesian robots
 XY-X
 SCARA robots
 YK-X
 Pick & place robots
 YP-X
 CLEAN
 CONTROLLER
 INFORMATION
 Robot positioner
 Pulse string driver
 Robot controller
 Electric gripper
 Option