

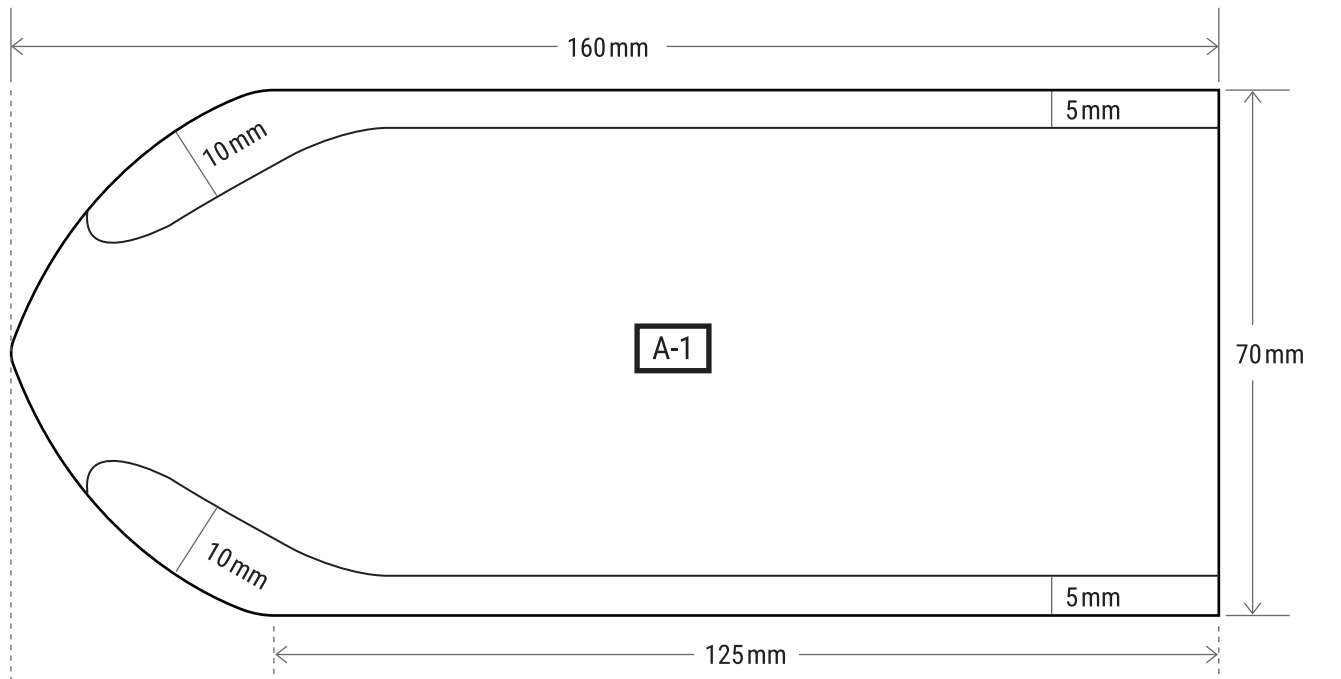

パーツ A

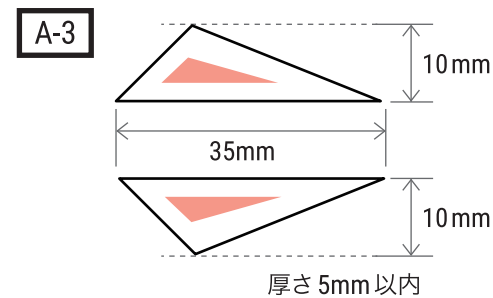

側面

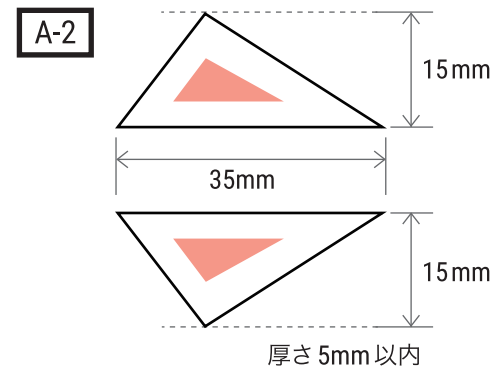
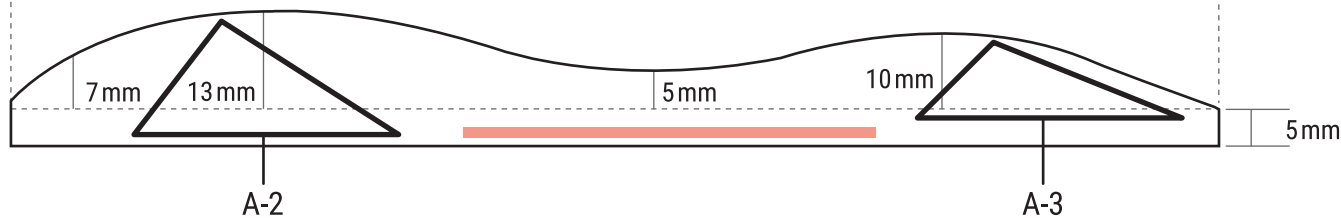



パーツ B

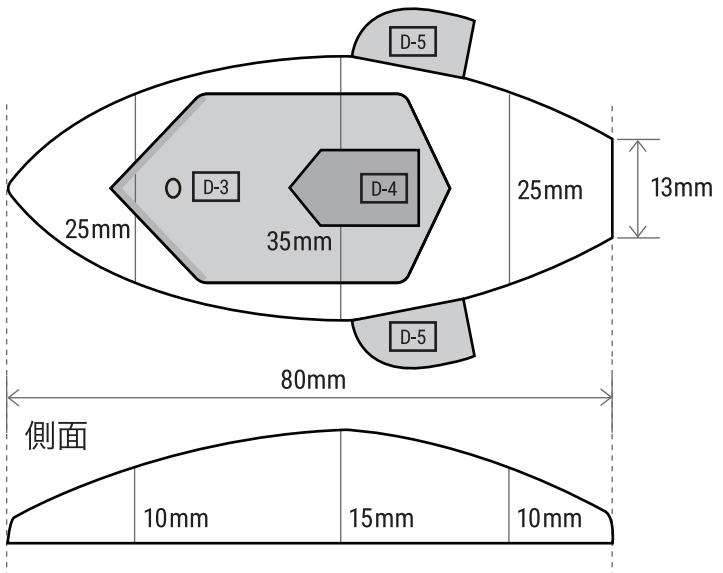

パーツ D

D-1

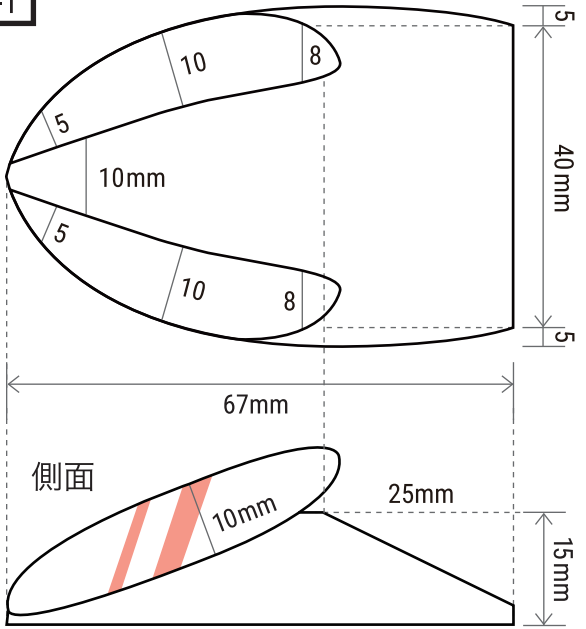

D-3

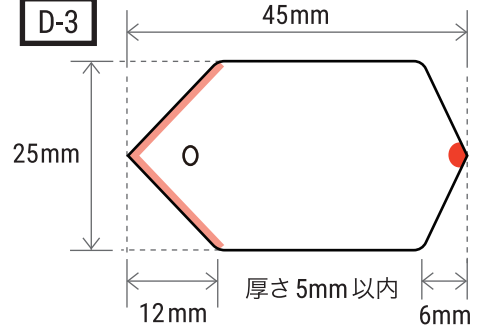

D-4

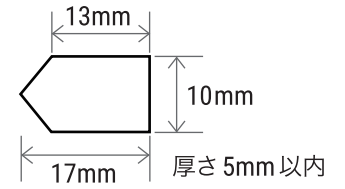

パーツ C

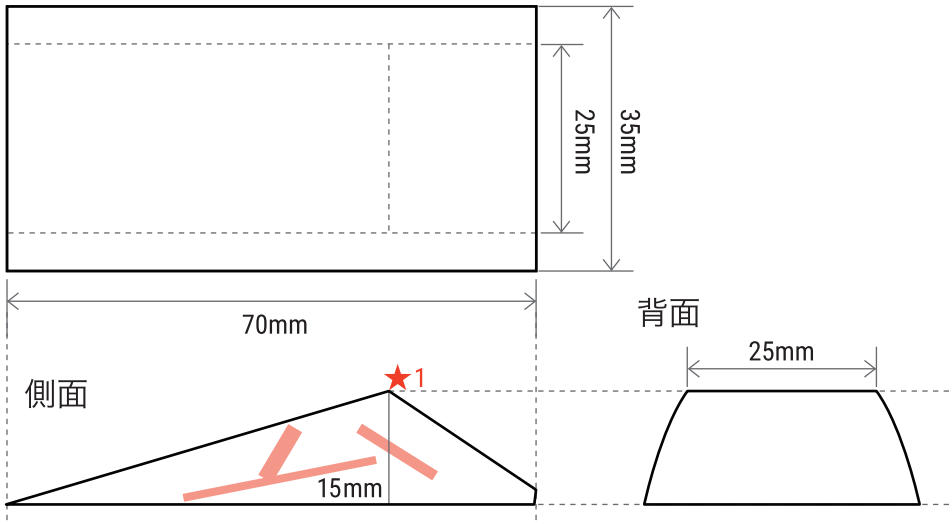

D-2

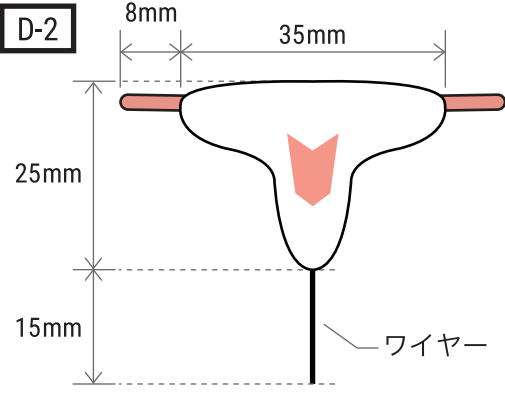

D-5

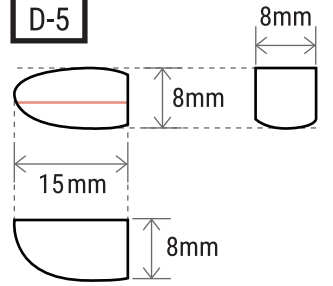



パーツ E

E-1

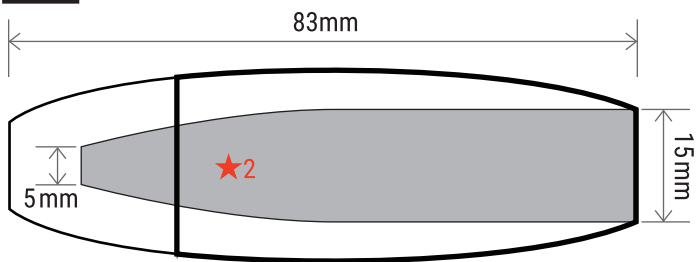

側面

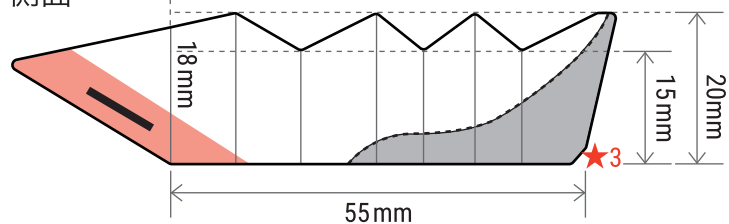

E-2

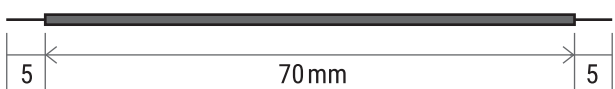

上面

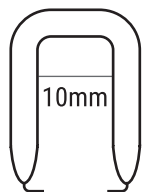

側面

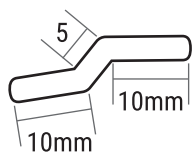

パーツ F

F-1

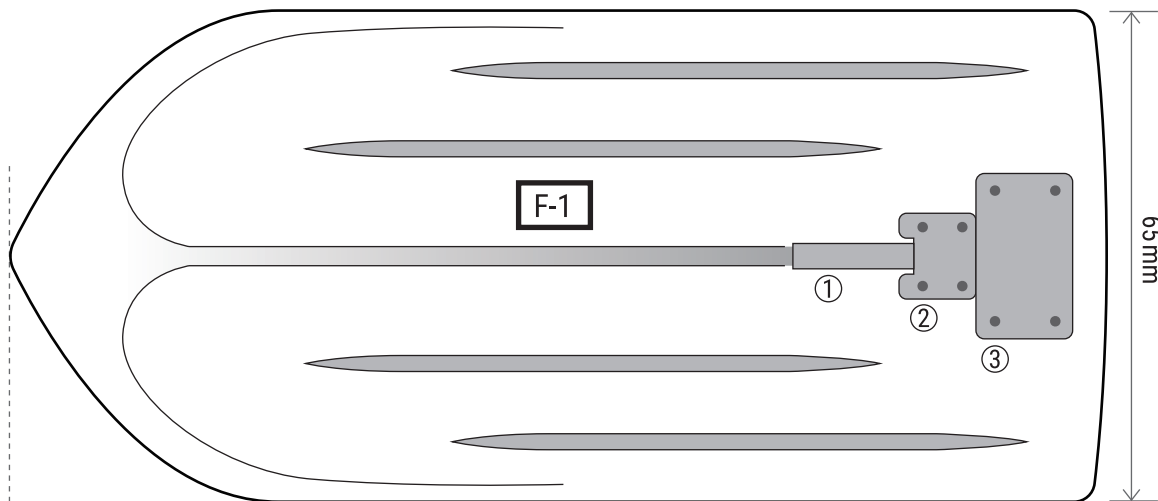

側面



背面

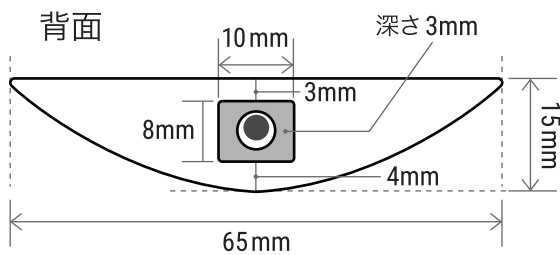

F-2

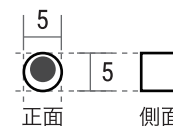

台座パーツ

×2

